



**冀诚电子**  
GEM-TECH ELECTRONICS

## LCD MODULE SPECIFICATIONS

Customer:
Customer Part No.:
Gem-tech Model Name:           GTK-384V8-FT6N2G
Release Date:   2014-11-7
Customer Approval:
Date:
The above signature represents that the product specifications, testing regulation, and warranty in the specifications are accepted.

**HEBEI GEM-TECH ELECTRONICS CO., LTD.**

No.368 North Xinshi Road, FL.8 Chuangxin BLD P.C.: 050091

Tel.: +86 311 8381 5999, 8381 6999      Fax.: +86 311 8383 1999

<http://www.gemtech-hb.com>

**Confidential**

This information contained herein is the exclusive property of Gem-tech and shall not be distributed, reproduced, or disclosed in whole or in part without prior written permission of Gem-tech. Subject to change without notice.

---

# Contents

1. BASIC SPECIFICATION
2. ABSOLUTE MAXIMUM RATINGS
3. ELECTRICAL & OPTICAL CHARACTERISTICS
4. TIMING CHARACTERISTICS
5. FUNCTION DESCRIPTION& INSTRUCTION SET
6. DIMENSIONAL OUTLINE
7. QUALITY SPECIFICATION
8. RELIABILITY
9. HANDLING PRECAUTION
10. PRECAUTION FOR USE
- 11.REVISIONS HISTORY

# 1. BASIC SPECIFICATION

## 1.1 THE FEATURE OF LCD MODULE ARE AS FOLLOWS.

- . DISPLAY MODE : FSTN-TRANSMISSIVE-POSITIVE
- . COLOR : DISPLAY DOT: BLACK  
DISPLAY BACKGROUNDND: GRAY
- . DISPLAY FORMAT : 128×64 DOTS
- . INPUT DATA : SERIAL DATA/PARALLEL DATA INPUT FROM A MPU
- . MULTIPLEXING : 1/65 DUTY
- . VIEWING DIRECTION : 6 O’CLOCK
- . DRIVED IC : ST7565R ( 1 CHIP)
- . BUILT IN DC-DC CONVERTER : INTER IC
- . BACK LIGHT : NONE

## 1.2 MECHANICAL SPECIFICATION

ITEM	SPECIFICATIONS	UNIT	REMARK
DIMENSIONAL OUTLINE	67.15(W)×48.15(H)×2.8MAX.(T)	mm	*REFERENCE DIMENSIONAL OUTLINE
VIEW AREA	60.0(W)×31.4(H)		
EFFECTIVE V/AREA	57.57(W)×28.77(H)		
NUMBER OF DOTS	128 DOTS×64 DOTS	--	
DOT PITCH	0.45(W)×0.45(H)	mm	
DOT SIZE	0.42(W)×0.42(H)	mm	

## 1.3 BLOCK DIAGRAM

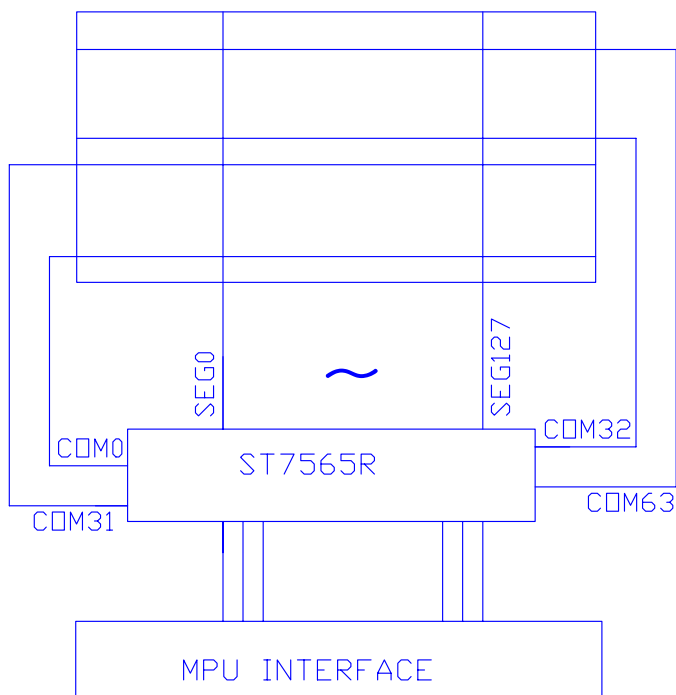

## 1.4 TERMINAL FUNCTIONS

PIN NO.	SYMBOL	LEVEL	FUNCTION
1	/CS1	H/L	Chip select signal
2	/RES	H/L	Reset Signal
3	A0(RS)	H/L	H: Display data; L: Instruction code
4	R/W	H/L	Write signal
5	E	H/L	Read signal
6~13	DB0-DB7	H/L	Data bus line
14	V <sub>DD</sub>	3.0V	Power supply
15	V <sub>SS</sub>	0V	Power supply(GND)
16	V <sub>out</sub>		DC/DC voltage output
17	NC		No connect
18	C3+		DC/DC voltage converter
19	C1-		DC/DC voltage converter
20	C1+		DC/DC voltage converter
21	C2+		DC/DC voltage converter
22	C2-		DC/DC voltage converter
23	V4		A multi-level power supply for the liquid crystal drive
24	V3		A multi-level power supply for the liquid crystal drive
25	V2		A multi-level power supply for the liquid crystal drive
26	V1		A multi-level power supply for the liquid crystal drive
27	V0		A multi-level power supply for the liquid crystal drive
28	P/S	H/L	H: Parallel data input/output. L: Serial data input.

## 2. ABSOLUTE MAXIMUM RATINGS ( Ta=25 °C, VSS=0V)

PARAMETER	SYMBOL	RATINGS			UNITS
		MIN.	TYP.	MAX.	
POWER SUPPLY FOR LOGIC	V <sub>DD</sub> -V <sub>SS</sub>	-0.3		3.6	V
POWER SUPPLY FOR LCD DRIVER	V <sub>LCD</sub>	-		14	V
INPUT VOLTAGE	V <sub>IN</sub>	-0.3	-	V <sub>DD</sub> +0.3	V
OPERATING TEMPERATURE	T <sub>opr</sub>	-20	-	70	°C
STORAGE TEMPERATURE	T <sub>stg</sub>	-30	-	80	°C

### 3. ELECTRICAL CHARACTERISTICS

#### 3.1 ELECTRICAL CHARACTERISTICS (Ta=25 °C)

ITEM	SYMBOL	CONDITION	MIN	TYPE	MAX.	UNIT	NOTE
LOGIC CIRCUIT POWER SUPPLY VOLTAGE	V <sub>DD</sub> -V <sub>SS</sub>	-----	3.0	3.3	3.6	V	
INPUT VOLTAGE	V <sub>IH</sub>	-----	0.7V <sub>DD</sub>	—	V <sub>DD</sub>	V	
INPUT VOLTAGE	V <sub>IL</sub>	-----	0	—	0.6	V	
LOGIC CIRCUIT POWER SUPPLY CURRENT	I <sub>DD</sub>	V <sub>DD</sub> -V <sub>SS</sub> =3.0	--	0.6	1	mA	
RECOMMENDED LCD DRIVING VOLTAGE	V <sub>LCD</sub> Φ=0 θ=0	Ta=25 °C	8.0	8.3	8.6	V	

#### 3.2 ELECTRO—OPTICAL CHARACTERISTICS (Ta=25 °C V<sub>DD</sub>=5.0±0.25V)

ITEM	SYMBOL	CONDITION	MIN	TYPE	MAX	UNIT	NOTE
VIEW ANGLE	φ2-φ1	K≥3	—	45	—	DEG	NOTE1,NOTE2
CONTRAST	K	φ=0° ,θ=0°	3	7	—	—	NOTE3
FRAME FREQUENCY				80		HZ	
RESPONSE TIME	Tr(rise)	φ=0° ,θ=0°	—	300	350	ms	
	Tf(fall)	φ=0° ,θ=0°	—	300	350	ms	NOTE4

NOTE1: Definition of Viewing Angle θ,φ

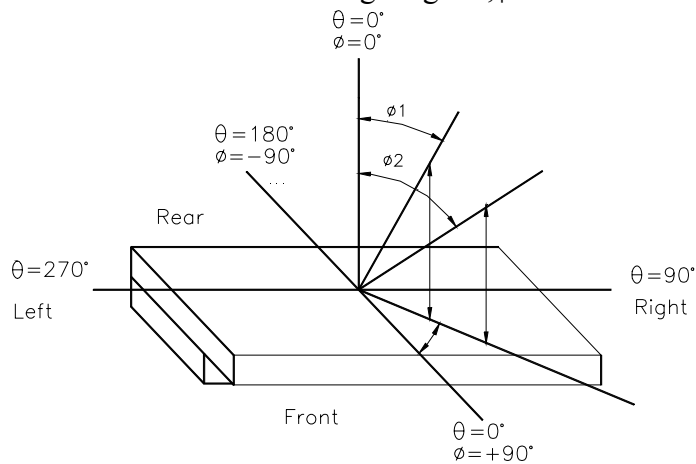

NOTE2: Definition of viewing Angle Range:  $\Delta \phi = |\phi 2 - \phi 1|$

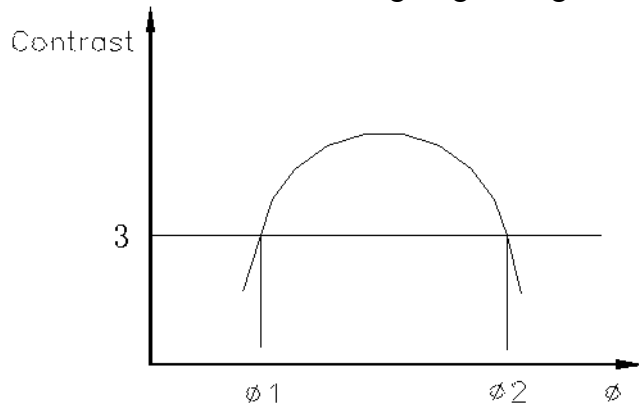

NOTE3: Definition of Contrast

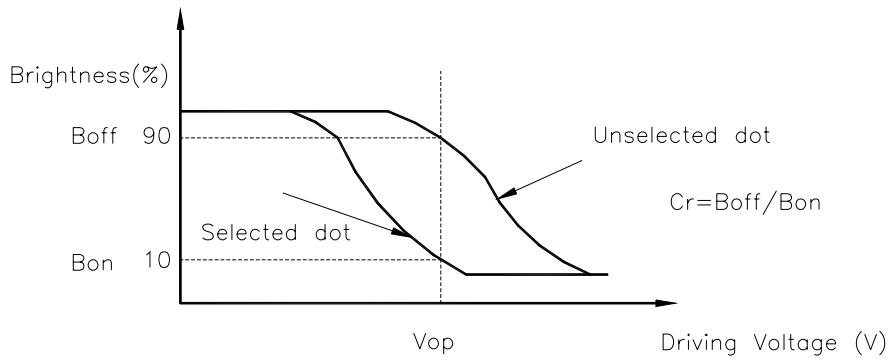

NOTE4: Definition of Response Time

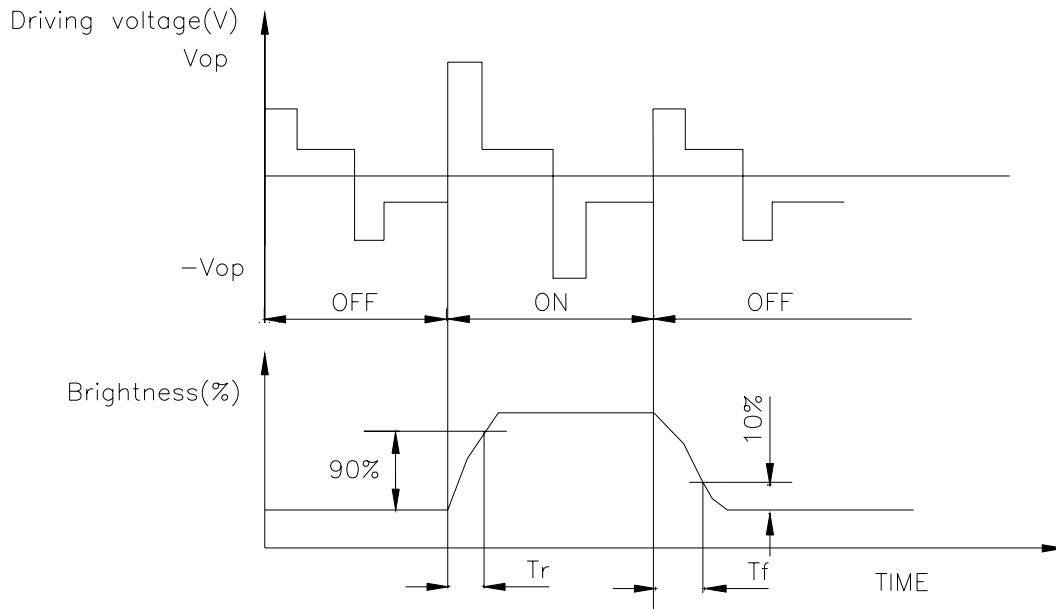

---

#### 4. TIMING CHARACTERISTICS

Please refer to “ST7565r” data sheet.

#### 5. FUNCTION DESCRIPTION& INSTRUCTION SET

Please refer to “ST7565r” data sheet.

## 6. DIMENSIONAL OUTLINE

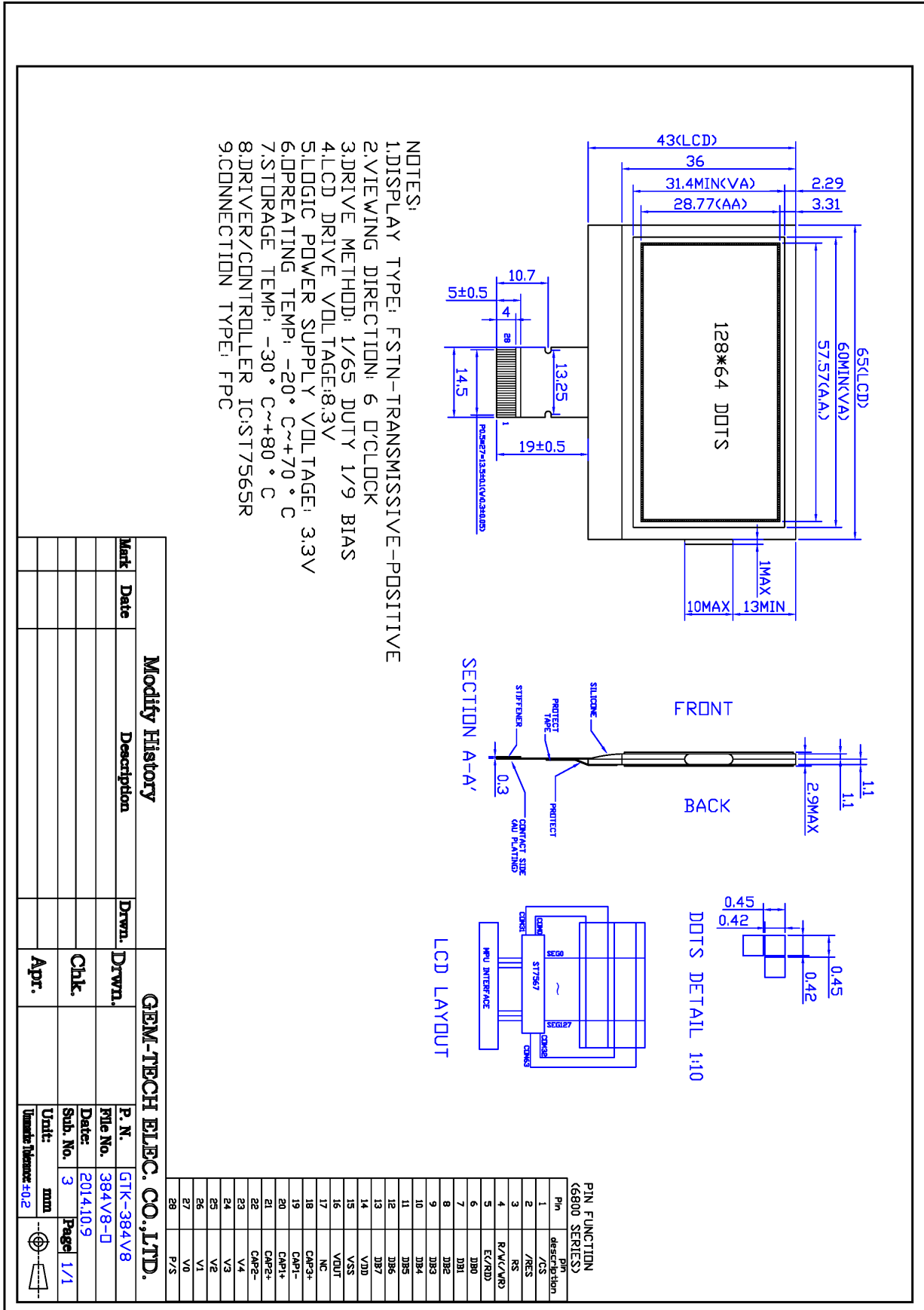

The tolerance unless specified: ±0.3mm



## 7.QUALITY SPECIFICATION

### 7-1.ACCEPTABLE QUALITY LEVEL

Inspection items	Sampling procedures	AQL
Visual-operating (Electro-optical)	GB2828.1-2012 Inspection level II Normal inspection Single sample inspection	0.65
Visual-not operating	GB2828.1-2012 Inspection level II Normal inspection Single sample inspection	1.5
Dimension measurement	GB2828.1-2012 Inspection level II Normal inspection Single sample inspection	1.5

### 7-2. INSPECTION CONDITIONS

#### 7-2-1. THE ENVIRONMENTAL

-Room temperature:  $25 \pm 3^{\circ}\text{C}$

-Humidity:  $65 \pm 20\%RH$

### 7-3. INSPECTION STANDARDS

#### 7-3-1. VISUAL WHILE OPERATING

Items to be inspected	Inspection standard
. No display	. If any pattern is not active at all, they can be rejected.
. Irregular operating	. No irregular operating are allowed . Appeared different display, which they should be chosen in the pattern, or appeared in different position where they should be chosen.
.Irregular display	. Any segment doesn't active, they can be rejected.
. Over current	. The total current required to activate the module should not be exceed the MAX current in specification.
.View angles	. Valves that don't meet the minimum value noted in the specification, they can be rejected.
.Contrast	. Valves that don't meet the minimum value noted in the specification, they can be reject.
.LCD operate voltage	. Meet the specification.

#### 7-3-2. Visual while not operating

Module dimension	. Meet the module outline drawing, not exceed the tolerance.
LCD panel scratch	.Following scratches inside the effective viewing area considered as the defects when their width & length are larger than the following combinations. Number: one or more Width: 0.1 length: 3.0 three or more Width: 0.05 length: 2.0 three or more Width: 0.03 length: 3.0 When the defects exceed this, it can be rejected.

---

## 8.RELIABILITY

### Standard Specification for Reliability of General-purpose LCM

Test Item	Test Condition	Note
High Temperature Store	80 °C,12hr.	2
Low Temperature Store	-30 °C,4hr	2
Humidity Store	40 °C,90%RH,96hr	1,2
High Temperature Operation	70°C,typical operating conditions,48hr	
Low Temperature Operation	-20°C,typical operating conditions,48hr	
Shock	Acceleration: 100m/s <sup>2</sup> , Pulse time: 11ms, 6 times in each direction of XYZ	
Mechanical Vibration	10~55Hz sweep, 3G, ampl.=0.75mm(max) XYZ for 20 min, each.	

Note 1: Condensation of water is not permitted on the module.

Note 2: The module should be inspected after 4 hour storage in normal conditions (15~35 °C,45~65%RH)

## 9. HANDLING PRECAUTION

### 9-1. MOUNTING METHOD

The panel of the LCD module consists of two thin glass plates with polarizes which easily get damaged since the module is fixed by utilizing fitting holes in the printed circuit board. Extreme care should be taken when handling the LCD modules.

### 9-2. CAUTION OF LCD HANDLING & CLEANING

When cleaning the display surface. Use soft cloth with solvent (recommended below) and wipe lightly.

- Isopropyl alcohol
- Ethyl alcohol
- Tri chlorotri fluoroethane

Do not wipe the display surface with dry or hard materials that will damage the polarizes surface.

Do not use the following solvent:

- Water
- Ketone
- Aromatics

### 9-3.CAUTION AGAINST STATIC CHARGE

The LCD modules use COMS LSI drivers. So we recommend that you connect any unused input terminal to Vdd or Vss, do not input any signals before power is turned on and ground your body. work/assembly table. And assembly equipment to protect against static electricity.

### 9-4.PACKAGING

-Modules use LCD elements, and must be treated as such avoid intense shock and falls from a height

-To prevent modules from degradation, do not operate or store them exposed directly to sunshine or high temperature/humidity.

### 9-5.CAUTION FOR OPERATION

---

-It is indispensable to drive LCM within the specified voltage limit since the higher voltage than the limit shortens LCM life.

-Response time will be extremely delayed at lower temperature than the operating temperature range and on the other hand at higher temperature LCD show dark color in them.

However those phenomena do not mean malfunction or out of order with LCD, which will come back in the specified operating temperature range.

-If the display area is pushed hard during operation. Some font will be abnormally displayed but it resumes normal condition after turning off once.

-A slight dew depositing on terminals is a cause for Electro-chemical reaction resulting in terminal open circuit.

Under the maximum operating temperature, 50%RH or less is required

#### 9-6 STORAGE

In the case of storing for a long period of time (for instance, for years) for the purpose or replacement use. the following ways are recommended

-Storage in a polyethylene bag with the opening sealed so as not to enter fresh air outside in it, and with no desiccant.

-Placing in a dark place where neither exposure to direct sunlight nor light is, keeping temperature in the specified storage temperature range.

-Storing with no touch on polarizes surface by the anythingelse.

(it is recommended to store them as they have been contained in the inner container at the time of delivery from us.

#### 9-7.SAFETY

-It is recommendable to crash damaged or unnecessary LCD into pieces and wash off liquid crystal by using solvents such as acetone and ethanol, which should be burned up later.

-When any liquid crystal leaked out of a damaged glass cell comes in contact with your hands, please wash it off well with soap and water.

### 10.PRECAUTION FOR USE

10-1.A limit sample should be provided by the both parties on an occasion when the both parties agree its necessity.

Judgement by a limit sample shall take effect after the limit sample has been established and confirmed by the both parties.

10-2.On the following occasions, the handling of problem should be decided through discussion and agreement between representative of the both parties

-When a question is arisen in this specification.

-When a new problem is arisen which is not specified in this specifications.

-When an inspection specification change or operating condition change in customer is reported to GEM-TECH, and some problem is arisen in this specification due to the change.

-When a new problem is arisen at the customer's operating set for sample evaluation in the customer size.

---

## 11.REVISIONS HISTORY

REVISION	DATE	DESCRIPTION
1.0	2014/11/7	First release