



深圳市华之洋光电科技有限公司

ShenZhen HZY Photoelectric Technology Co., Ltd

地址:
深圳市光明新区光明街道同富裕工业区 4 栋 4 楼

Tel: +86-0755-29100020
+86-0755-27388699

Address: 4F,#4 Building, Tongfuyu Industrial
Park, Guangming District, ShenZhen, China.

Fax: +86-0755-29100030
Web: www.hzy-lcd.com

SPECIFICATION

CUSTOMER :

MODULE NO.:

H1601L-WMI-JT00

| | | |
|--|-------------|-------|
| APPROVED BY: (FOR CUSTOMER USE ONLY) | | |
| | PCB VERION: | DATA: |

| SALES BY | APPROVED BY | CHECKED BY | PREPARED BY |
|----------------------------------|-------------|------------|-------------|
| | | | |
| ISSUED DATE: 2017-12-21 (Rev.V1) | | | |

Contents

1. Module Classification Information
2. Precautions in use of LCD Modules
3. General Specification
4. Absolute Maximum Ratings
5. Electrical Characteristics
6. Optical Characteristics
7. Interface Pin Function
8. Contour Drawing & Block Diagram
9. Function Description
10. Character Generator ROM Pattern
11. Instruction Table
12. Timing Characteristics
13. Initializing of LCM
14. Reliability
15. Backlight Information
16. Inspection specification
17. Material List of Components for Rohs

1.Module Classification Information

H 1601 L - W MI - JT **

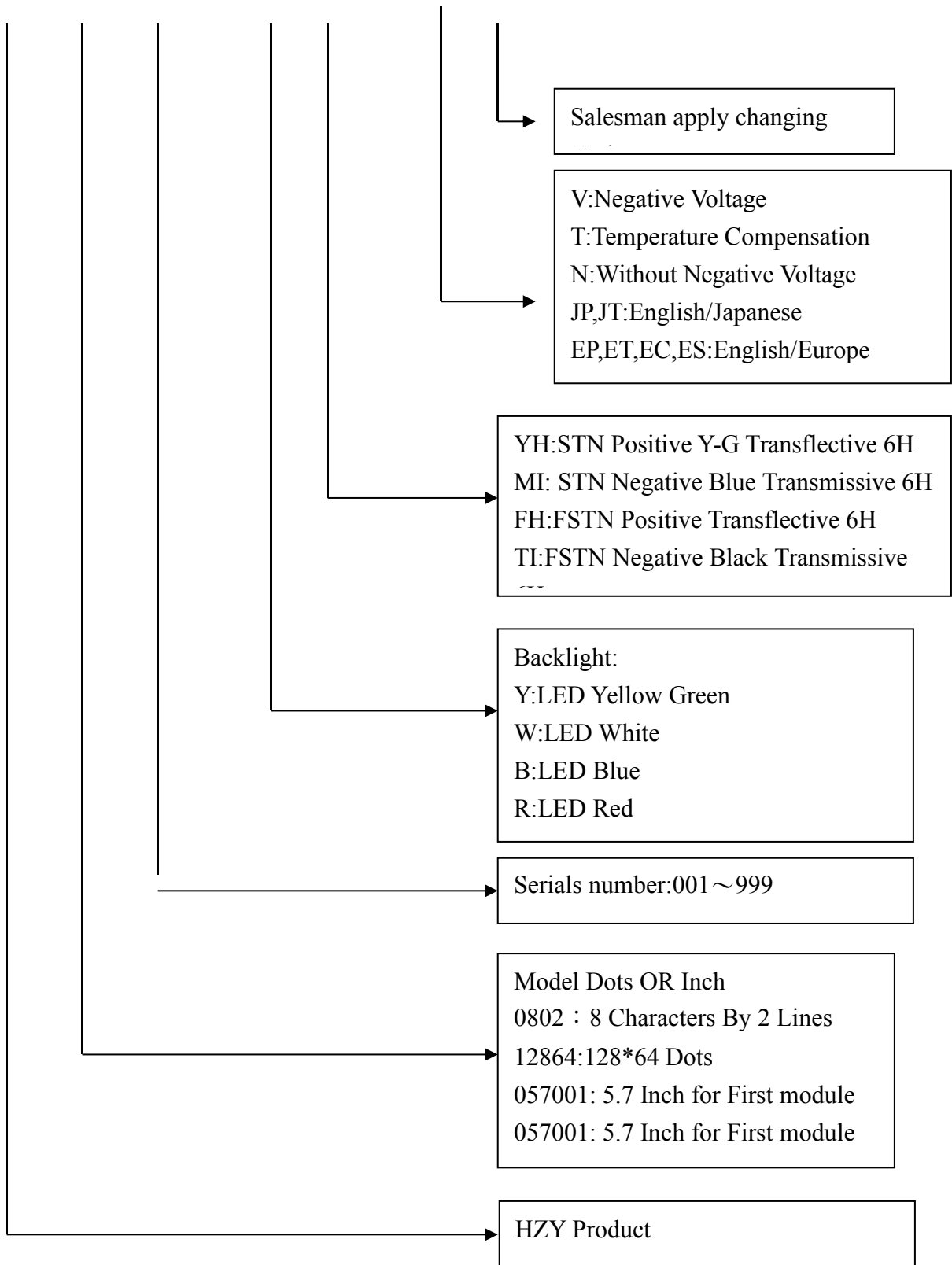

2.Precautions in use of LCD Modules

- (1) Avoid applying excessive shocks to the module or making any alterations or modifications to it.
- (2) Don't make extra holes on the printed circuit board, modify its shape or change the components of LCD module.
- (3) Don't disassemble the LCM.
- (4) Don't operate it above the absolute maximum rating.
- (5) Don't drop, bend or twist LCM.
- (6) Soldering: only to the I/O terminals.
- (7) Storage: please storage in anti-static electricity container and clean environment.
- (8) The LCM must be input negative voltage to Vo when temperature below -10°C.

3.General Specification

| Item | Dimension | Unit |
|----------------------|--|-------------|
| Number of Characters | 16 characters x 1 Lines | — |
| Module dimension | 122.0 x 33.0 x 13.5(MAX) | mm |
| View area | 99.0 x 13.0 | mm |
| Active area | 94.84 x 9.66 | mm |
| Dot size | 0.92 x 1.1 | mm |
| Dot pitch | 0.98 x 1.16 | mm |
| Character size | 4.84 x 8.06 | mm |
| Character pitch | 6.0 x 8.56 | mm |
| LCD type | STN/Blue,Negative, Transmissive (In LCD production, It will occur slightly color difference. We can only guarantee the same color in the same batch.) | |
| Duty | 1/16 | |
| View direction | 6 o'clock | |
| Backlight Type | LED White | |
| Controller | ST7066U-0A(English / Japan) or compatible | |

4. Absolute Maximum Ratings

| Item | Symbol | Min | Typ | Max | Unit |
|--------------------------|-----------------|----------|-----|----------|------|
| Operating Temperature | T_{OP} | -20 | — | +70 | °C |
| Storage Temperature | T_{ST} | -30 | — | +80 | °C |
| Input Voltage | V_I | V_{SS} | — | V_{DD} | V |
| Supply Voltage For Logic | $V_{DD}-V_{SS}$ | -0.3 | — | 7 | V |
| Supply Voltage For LCD | $V_{DD}-V_0$ | -0.3 | — | 7 | V |

5. Electrical Characteristics

| Item | Symbol | Condition | Min | Typ | Max | Unit |
|--------------------------|-----------------|---------------------------|--------------|-----|----------|------|
| Supply Voltage For Logic | $V_{DD}-V_{SS}$ | — | 4.5 | 5.0 | 5.5 | V |
| Supply Voltage For LCD | $V_{DD}-V_0$ | $T_a=-20^{\circ}\text{C}$ | — | — | 5.5 | V |
| | | $T_a=25^{\circ}\text{C}$ | — | 4.5 | — | V |
| | | $T_a=70^{\circ}\text{C}$ | 3.5 | — | — | V |
| Input High Volt. | V_{IH} | — | $0.7 V_{DD}$ | — | V_{DD} | V |
| Input Low Volt. | V_{IL} | — | V_{SS} | — | 0.6 | V |
| Output High Volt. | V_{OH} | — | 3.9 | — | — | V |
| Output Low Volt. | V_{OL} | — | — | — | 0.4 | V |
| Supply Current | I_{DD} | $V_{DD}=5\text{V}$ | 1.0 | 1.2 | 1.5 | mA |

6. Optical Characteristics

| Item | Symbol | Condition | Min | Typ | Max | Unit |
|----------------|---------------|-------------|-----|-----|-----|------|
| View Angle | (V) θ | $CR \geq 2$ | 20 | — | 40 | deg |
| | (H) φ | $CR \geq 2$ | -30 | — | 30 | deg |
| Contrast Ratio | CR | — | — | 3 | — | — |
| Response Time | T rise | — | — | 150 | 200 | ms |
| | T fall | — | — | 150 | 200 | ms |

Definition of Operation Voltage (Vop)

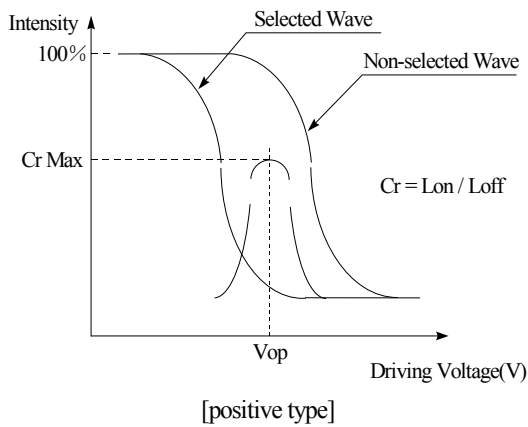

Definition of Response Time (Tr, Tf)

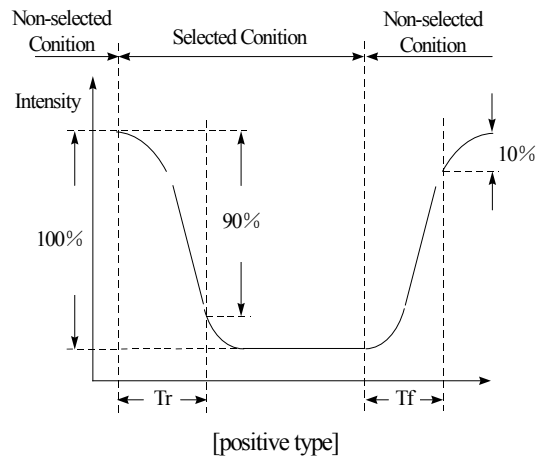

Conditions :

Operating Voltage : Vop Viewing Angle(θ , φ) : 0° , 0°
 Frame Frequency : 64 HZ Driving Waveform : 1/N duty , 1/a bias

Definition of viewing angle($CR \geq 2$)

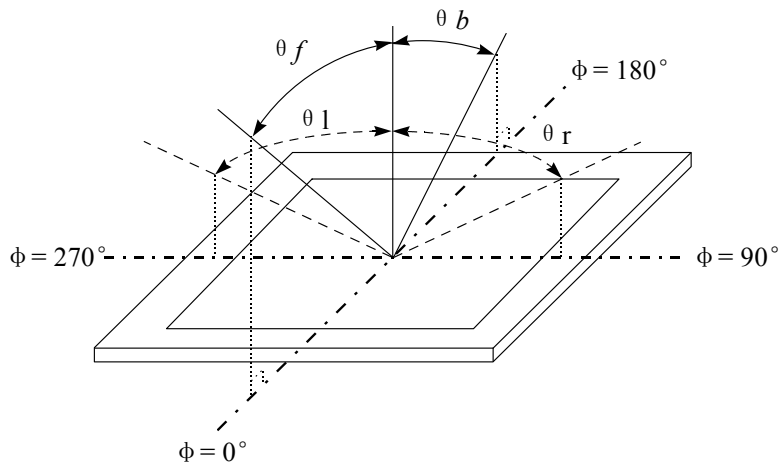

7.Interface Pin Function

| Pin No. | Symbol | Level | Description |
|----------------|-----------------|--------------|--|
| 1 | V _{SS} | 0V | Ground |
| 2 | V _{DD} | 5.0V | Supply Voltage for logic |
| 3 | VO | (Variable) | Operating voltage for LCD |
| 4 | RS | H/L | H: DATA, L: Instruction code |
| 5 | R/W | H/L | H: Read(MPU→Module) L: Write(MPU→Module) |
| 6 | E | H,H→L | Chip enable signal |
| 7 | DB0 | H/L | Data bus line |
| 8 | DB1 | H/L | Data bus line |
| 9 | DB2 | H/L | Data bus line |
| 10 | DB3 | H/L | Data bus line |
| 11 | DB4 | H/L | Data bus line |
| 12 | DB5 | H/L | Data bus line |
| 13 | DB6 | H/L | Data bus line |
| 14 | DB7 | H/L | Data bus line |
| 15 | A | — | LED + |
| 16 | K | — | LED — |

8. Contour Drawing & Block Diagram

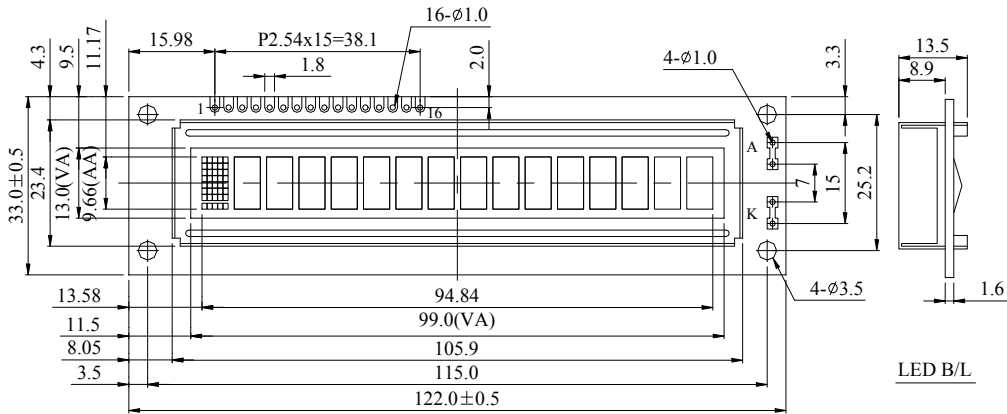

| PIN NO. | SYMBOL |
|---------|--------|
| 1 | Vss |
| 2 | Vdd |
| 3 | Vo |
| 4 | RS |
| 5 | R/W |
| 6 | E |
| 7 | DB0 |
| 8 | DB1 |
| 9 | DB2 |
| 10 | DB3 |
| 11 | DB4 |
| 12 | DB5 |
| 13 | DB6 |
| 14 | DB7 |
| 15 | A |
| 16 | K |

| LED-H/L B/L | |
|-------------|----------|
| | High Low |
| H1 | 13.5 |
| H2 | 8.9 |

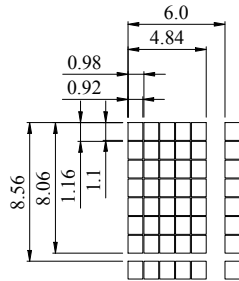

DOT SIZE
S = 3 : 1

The non-specified tolerance of dimension is ±0.3mm.

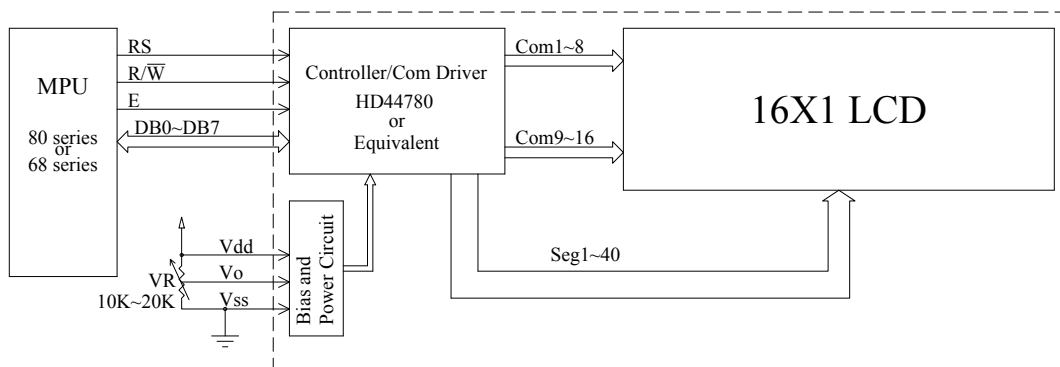

External contrast adjustment.

| | | | | | | | | | | | | | | | | |
|-------------------|----|----|----|----|----|----|----|----|----|----|----|----|----|----|----|----|
| Character located | 1 | 2 | 3 | 4 | 5 | 6 | 7 | 8 | 9 | 10 | 11 | 12 | 13 | 14 | 15 | 16 |
| DDRAM address | 00 | 01 | 02 | 03 | 04 | 05 | 06 | 07 | 40 | 41 | 42 | 43 | 44 | 45 | 46 | 47 |

2-line display mode.

9. Function Description

The LCD display Module is built in a LSI controller, the controller has two 8-bit registers, an instruction register (IR) and a data register (DR).

The IR stores instruction codes, such as display clear and cursor shift, and address information for display data RAM (DDRAM) and character generator (CGRAM). The IR can only be written from the MPU. The DR temporarily stores data to be written or read from DDRAM or CGRAM. When address information is written into the IR, then data is stored into the DR from DDRAM or CGRAM. By the register selector (RS) signal, these two registers can be selected.

| RS | R/W | Operation |
|----|-----|---|
| 0 | 0 | IR write as an internal operation (display clear, etc.) |
| 0 | 1 | Read busy flag (DB7) and address counter (DB0 to DB7) |
| 1 | 0 | Write data to DDRAM or CGRAM (DR to DDRAM or CGRAM) |
| 1 | 1 | Read data from DDRAM or CGRAM (DDRAM or CGRAM to DR) |

Busy Flag (BF)

When the busy flag is 1, the controller LSI is in the internal operation mode, and the next instruction will not be accepted. When RS=0 and R/W=1, the busy flag is output to DB7. The next instruction must be written after ensuring that the busy flag is 0.

Address Counter (AC)

The address counter (AC) assigns addresses to both DDRAM and CGRAM

Display Data RAM (DDRAM)

This DDRAM is used to store the display data represented in 8-bit character codes. Its extended capacity is 80x8 bits or 80 characters. Below figure is the relationships between DDRAM addresses and positions on the liquid crystal display.

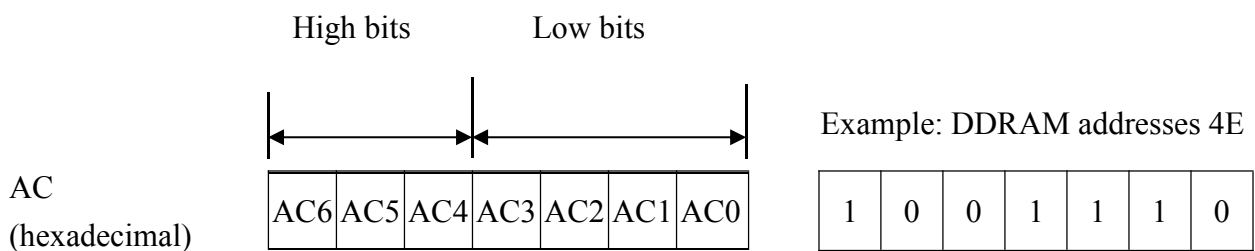

Display position DDRAM address

| | | | | | | | | | | | | | | | |
|----|----|----|----|----|----|----|----|----|----|----|----|----|----|----|----|
| 1 | 2 | 3 | 4 | 5 | 6 | 7 | 8 | 9 | 10 | 11 | 12 | 13 | 14 | 15 | 16 |
| 00 | 01 | 02 | 03 | 04 | 05 | 06 | 07 | 40 | 41 | 42 | 43 | 44 | 45 | 46 | 47 |
| | | | | | | | | | | | | | | | |

2-Line by 16-Character Display

Character Generator ROM (CGROM)

The CGROM generate 5×8 dot or 5×10 dot character patterns from 8-bit character codes. See Table 2.

Character Generator RAM (CGRAM)

In CGRAM, the user can rewrite character by program. For 5×8 dots, eight character patterns can be written, and for 5×10 dots, four character patterns can be written.

Write into DDRAM the character code at the addresses shown as the left column of table 1. To show the character patterns stored in CGRAM.

Relationship between CGRAM Addresses, Character Codes (DDRAM) and Character patterns

Table 1.

For 5 * 8 dot character patterns

| Character Codes (DDRAM data) | | | | | | | | CGRAM Address | | | | | | Character Patterns (CGRAM data) | | | | | | | | | | | | | | | | | | | | | | | |
|--------------------------------|---|---|---|-----|---|---|---|---------------|--|--|-----|--|--|-----------------------------------|---|---|---|-----|---|---|----------------|------------------------|-------|--|--|--|--|--|-------|---|---|---|--|--|--|--|----------------|
| 7 | 6 | 5 | 4 | 3 | 2 | 1 | 0 | 5 | | | 4 | | | 3 | | | 2 | | | 1 | | | 0 | | | | | | | | | | | | | | |
| High | | | | Low | | | | High | | | Low | | | High | | | | Low | | | | | | | | | | | | | | | | | | | |
| 0 0 0 0 * 0 0 0 | | | | | | | | 0 0 0 | | | | | | 0 0 0 | * | * | * | 0 | | | | Character pattern(1) | | | | | | | | | | | | | | | |
| | | | | | | | | | | | | | | 0 0 1 | * | * | * | 0 | 0 | 0 | Cursor pattern | | | | | | | | | | | | | | | | |
| | | | | | | | | | | | | | | 0 1 0 | * | * | * | 0 | 0 | 0 | | | | | | | | | | | | | | | | | |
| | | | | | | | | | | | | | | 0 1 1 | * | * | * | 0 | 0 | 0 | | | | | | | | | | | | | | | | | |
| | | | | | | | | | | | | | | 1 0 0 | * | * | * | 0 | 0 | 0 | | | | | | | | | | | | | | | | | |
| | | | | | | | | | | | | | | 1 0 1 | * | * | * | 0 | 0 | 0 | | | | | | | | | | | | | | | | | |
| | | | | | | | | | | | | | | 1 1 0 | * | * | * | 0 | 0 | 0 | | | | | | | | | | | | | | | | | |
| | | | | | | | | | | | | | | 1 1 1 | * | * | * | 0 | 0 | 0 | | | | | | | | | | | | | | | | | |
| | | | | | | | | | | | | | | 0 0 0 | * | * | * | 0 | 0 | 0 | | | | | | | | | | | | | | | | | |
| | | | | | | | | | | | | | | 0 0 1 | * | * | * | 0 | 0 | 0 | | | | | | | | | | | | | | | | | |
| 0 0 0 0 * 0 0 1 | | | | | | | | 0 0 1 | | | | | | 0 1 0 | * | * | * | 0 | 0 | 0 | | Character pattern(2) | | | | | | | | | | | | | | | |
| | | | | | | | | | | | | | | 0 1 1 | * | * | * | 0 | 0 | 0 | | | | | | | | | | | | | | | | | |
| | | | | | | | | | | | | | | 1 0 0 | * | * | * | 0 | 0 | 0 | | | | | | | | | | | | | | | | | |
| | | | | | | | | | | | | | | 1 0 1 | * | * | * | 0 | 0 | 0 | | | | | | | | | | | | | | | | | |
| | | | | | | | | | | | | | | 1 1 0 | * | * | * | 0 | 0 | 0 | | | | | | | | | | | | | | | | | |
| | | | | | | | | | | | | | | 1 1 1 | * | * | * | 0 | 0 | 0 | | | | | | | | | | | | | | | | | |
| | | | | | | | | | | | | | | 0 0 0 | * | * | * | 0 | 0 | 0 | | | | | | | | | | | | | | | | | |
| | | | | | | | | | | | | | | 0 0 1 | * | * | * | 0 | 0 | 0 | | | | | | | | | | | | | | | | | |
| | | | | | | | | | | | | | | 0 0 0 0 * 1 1 1 | | | | | | | | | 1 1 1 | | | | | | 1 0 0 | * | * | * | | | | | Cursor pattern |
| | | | | | | | | | | | | | | | | | | | | | | | | | | | | | 1 0 1 | * | * | * | | | | | |
| 1 1 0 | * | * | * | | | | | | | | | | | | | | | | | | | | | | | | | | | | | | | | | | |
| 1 1 1 | * | * | * | | | | | | | | | | | | | | | | | | | | | | | | | | | | | | | | | | |

For 5 * 10 dot character patterns

| Character Codes (DDRAM data) | | | | | | | | | | CGRAM Address | | | | | | | | | | Character Patterns (CGRAM data) | | | | | | | | | | | | | | | | | |
|--------------------------------|---|---|---|---|-----|---|---|---|--|---------------|--|--|---|--|-----|--|--|---|--|-----------------------------------|---|---|---|---|-----|---|---|---|----------------|-------------------|--|--|---|--|--|--|--|
| 7 | 6 | 5 | 4 | 3 | 2 | 1 | 0 | 5 | | | | | 4 | | | | | 3 | | | | | 2 | | | | | 1 | | | | | 0 | | | | |
| High | | | | | Low | | | | | High | | | | | Low | | | | | High | | | | | Low | | | | | | | | | | | | |
| 0 0 0 0 * 0 0 0 | | | | | | | | | | 0 0 | | | | | | | | | | 0 0 0 0 0 | * | * | * | 0 | 0 | 0 | 0 | 0 | 0 | Character pattern | | | | | | | |
| | | | | | | | | | | | | | | | | | | | | 0 0 0 0 1 | * | * | * | 0 | 0 | 0 | 0 | 0 | | | | | | | | | |
| | | | | | | | | | | | | | | | | | | | | 0 0 1 0 0 | * | * | * | 0 | 0 | 0 | 0 | 0 | | | | | | | | | |
| | | | | | | | | | | | | | | | | | | | | 0 0 1 1 1 | * | * | * | 0 | 0 | 0 | 0 | 0 | | | | | | | | | |
| | | | | | | | | | | | | | | | | | | | | 0 1 0 0 0 | * | * | * | 0 | 0 | 0 | 0 | 0 | | | | | | | | | |
| | | | | | | | | | | | | | | | | | | | | 0 1 0 1 1 | * | * | * | 0 | 0 | 0 | 0 | 0 | | | | | | | | | |
| | | | | | | | | | | | | | | | | | | | | 0 1 1 0 0 | * | * | * | 0 | 0 | 0 | 0 | 0 | | | | | | | | | |
| | | | | | | | | | | | | | | | | | | | | 0 1 1 1 1 | * | * | * | 0 | 0 | 0 | 0 | 0 | | | | | | | | | |
| | | | | | | | | | | | | | | | | | | | | 1 0 0 0 0 | * | * | * | 0 | 0 | 0 | 0 | 0 | | | | | | | | | |
| | | | | | | | | | | | | | | | | | | | | 1 0 0 1 1 | * | * | * | 0 | 0 | 0 | 0 | 0 | | | | | | | | | |
| 0 0 0 0 * 1 1 1 | | | | | | | | | | 1 1 1 1 | | | | | | | | | | 1 0 1 0 0 | * | * | * | 0 | 0 | 0 | 0 | 0 | Cursor pattern | | | | | | | | |
| | | | | | | | | | | | | | | | | | | | | 1 0 1 1 1 | * | * | * | 0 | 0 | 0 | 0 | 0 | | | | | | | | | |
| | | | | | | | | | | | | | | | | | | | | 1 1 0 0 0 | * | * | * | 0 | 0 | 0 | 0 | 0 | | | | | | | | | |
| | | | | | | | | | | | | | | | | | | | | 1 1 0 1 1 | * | * | * | 0 | 0 | 0 | 0 | 0 | | | | | | | | | |

■ : " High "

10.Character Generator ROM Pattern

Table.2

NO.7066-0A

| b_7-b_4 b_3-b_0 | 0000 | 0001 | 0010 | 0011 | 0100 | 0101 | 0110 | 0111 | 1000 | 1001 | 1010 | 1011 | 1100 | 1101 | 1110 | 1111 |
|------------------------|------------------|------|------|------|------|------|------|------|------|------|------|------|------|------|------|---|
| 0000 | CG RAM (1) | | | 0 | a | P | \ | P | | | | - | 9 | E | a | P |
| 0001 | (2) | | ! | 1 | A | Q | a | 9 | | | u | 7 | 7 | 4 | a | 9 |
| 0010 | (3) | | " | 2 | B | R | b | r | | | r | Y | Y | X | P | 0 |
| 0011 | (4) | | # | 3 | C | S | c | s | | | J | U | T | E | S | * |
| 0100 | (5) | | \$ | 4 | D | T | d | t | | | \ | E | T | + | u | 0 |
| 0101 | (6) | | % | 5 | E | U | e | u | | | . | + | + | 1 | 0 | 0 |
| 0110 | (7) | | & | 6 | F | V | f | v | | | 7 | 0 | = | 0 | P | Z |
| 0111 | (8) | | ' | 7 | G | W | g | w | | | 7 | + | X | 7 | g | π |
| 1000 | (1) | | (| 8 | H | X | h | x | | | Y | U | * | U | J | X |
| 1001 | (2) | |) | 9 | I | Y | i | y | | | 0 | U | J | U | ' | y |
| 1010 | (3) | | * | : | J | Z | j | z | | | u | 0 | n | V | J | + |
| 1011 | (4) | | + | ; | K | L | k | l | | | * | 7 | E | 0 | * | π |
| 1100 | (5) | | , | < | L | ¥ | l | l | | | + | 0 | 7 | 7 | 0 | π |
| 1101 | (6) | | - | = | M | I | m | l | | | u | X | \ | U | E | + |
| 1110 | (7) | | . | > | N | ^ | n | + | | | 0 | E | 0 | * | n | |
| 1111 | (8) | | / | ? | O | _ | o | + | | | u | U | X | " | 0 |  |

11. Instruction Table

| Instruction | Instruction Code | | | | | | | | | | Description | Execution time (fosc=270Khz) |
|----------------------------|------------------|-----|-----|-----|-----|-----|-----|-----|-----|-----|--|---------------------------------|
| | RS | R/W | DB7 | DB6 | DB5 | DB4 | DB3 | DB2 | DB1 | DB0 | | |
| Clear Display | 0 | 0 | 0 | 0 | 0 | 0 | 0 | 0 | 0 | 1 | Write "00H" to DDRAM and set DDRAM address to "00H" from AC | 1.53ms |
| Return Home | 0 | 0 | 0 | 0 | 0 | 0 | 0 | 0 | 1 | — | Set DDRAM address to "00H" from AC and return cursor to its original position if shifted. The contents of DDRAM are not changed. | 1.53ms |
| Entry Mode Set | 0 | 0 | 0 | 0 | 0 | 0 | 0 | 1 | I/D | SH | Assign cursor moving direction and enable the shift of entire display. | 39 μs |
| Display ON/OFF Control | 0 | 0 | 0 | 0 | 0 | 0 | 1 | D | C | B | Set display (D), cursor (C), and blinking of cursor (B) on/off control bit. | 39 μs |
| Cursor or Display Shift | 0 | 0 | 0 | 0 | 0 | 1 | S/C | R/L | — | — | Set cursor moving and display shift control bit, and the direction, without changing of DDRAM data. | 39 μs |
| Function Set | 0 | 0 | 0 | 0 | 1 | DL | N | F | — | — | Set interface data length (DL:8-bit/4-bit), numbers of display line (N:2-line/1-line)and, display font type (F:5×11 dots/5×8 dots) | 39 μs |
| Set CGRAM Address | 0 | 0 | 0 | 1 | AC5 | AC4 | AC3 | AC2 | AC1 | AC0 | Set CGRAM address in address counter. | 39 μs |
| Set DDRAM Address | 0 | 0 | 1 | AC6 | AC5 | AC4 | AC3 | AC2 | AC1 | AC0 | Set DDRAM address in address counter. | 39 μs |
| Read Busy Flag and Address | 0 | 1 | BF | AC6 | AC5 | AC4 | AC3 | AC2 | AC1 | AC0 | Whether during internal operation or not can be known by reading BF. The contents of address counter can also be read. | 0 μs |
| Write Data to RAM | 1 | 0 | D7 | D6 | D5 | D4 | D3 | D2 | D1 | D0 | Write data into internal RAM (DDRAM/CGRAM). | 43 μs |
| Read Data from RAM | 1 | 1 | D7 | D6 | D5 | D4 | D3 | D2 | D1 | D0 | Read data from internal RAM (DDRAM/CGRAM). | 43 μs |

* "—" : don't care

12. Timing Characteristics

12.1 Write Operation

- Writing data from MPU

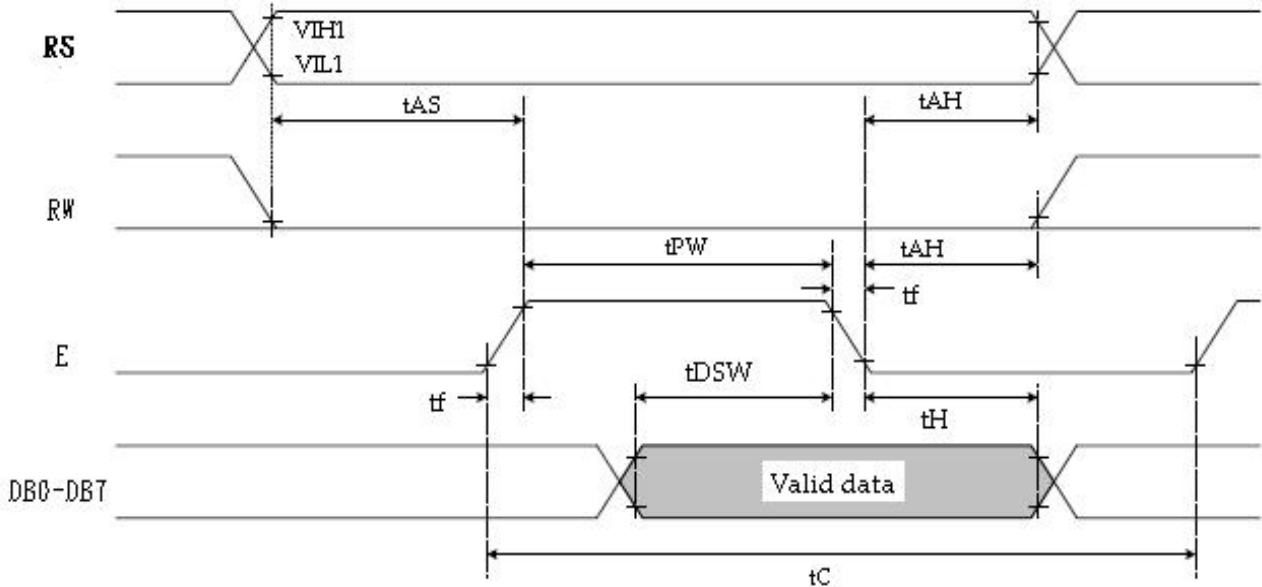

Ta=25°C, VDD=5.0V

| Item | Symbol | Min | Typ | Max | Unit |
|------------------------------------|---------------------------------|------|-----|-----|------|
| Enable cycle time | T _C | 1200 | — | — | ns |
| Enable pulse width | T _{PW} | 140 | — | — | ns |
| Enable rise/fall time | T _R , T _F | — | — | 25 | ns |
| Address set-up time (RS, R/W to E) | t _{AS} | 0 | — | — | ns |
| Address hold time | t _{AH} | 10 | — | — | ns |
| Data set-up time | t _{DSW} | 40 | — | — | ns |
| Data hold time | t _H | 10 | — | — | ns |

12.2 Read Operation

- Reading data from ST7066U

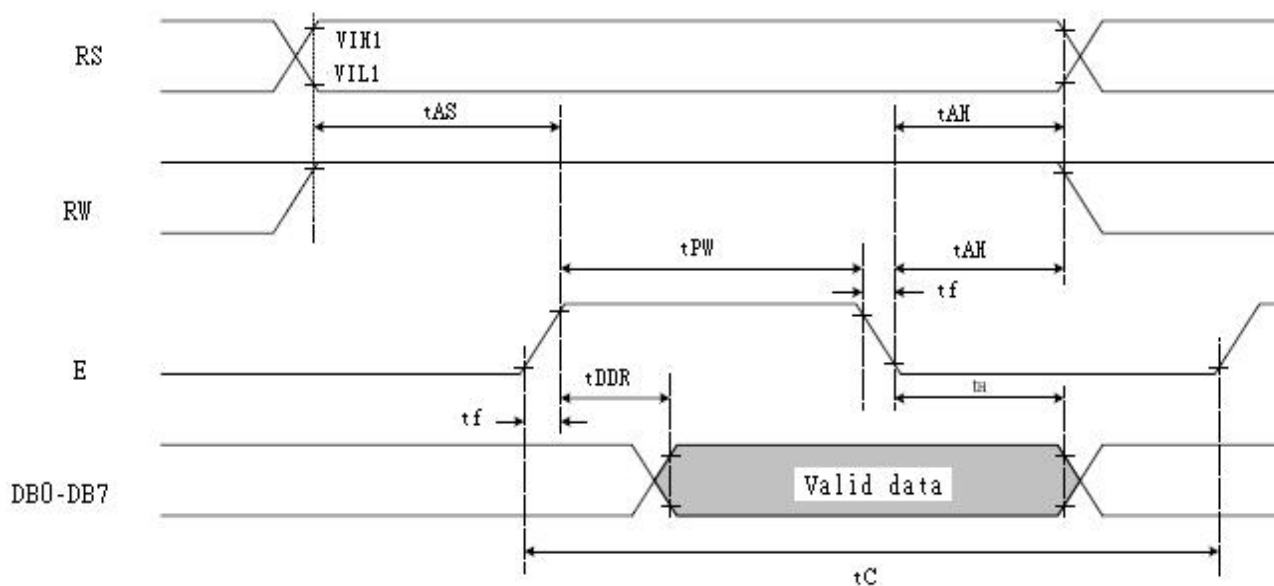

$T_a=25^{\circ}\text{C}$, $V_{DD}=5\text{V}$

| Item | Symbol | Min | Typ | Max | Unit |
|------------------------------------|------------|------|-----|-----|------|
| Enable cycle time | T_C | 1200 | — | — | ns |
| Enable pulse width (high level) | T_{PW} | 140 | — | — | ns |
| Enable rise/fall time | T_R, T_F | — | — | 25 | ns |
| Address set-up time (RS, R/W to E) | t_{AS} | 0 | — | — | ns |
| Address hold time | t_{AH} | 10 | — | — | ns |
| Data delay time | t_{DDR} | — | — | 100 | ns |
| Data hold time | t_H | 10 | — | — | ns |

13. Initializing of LCM

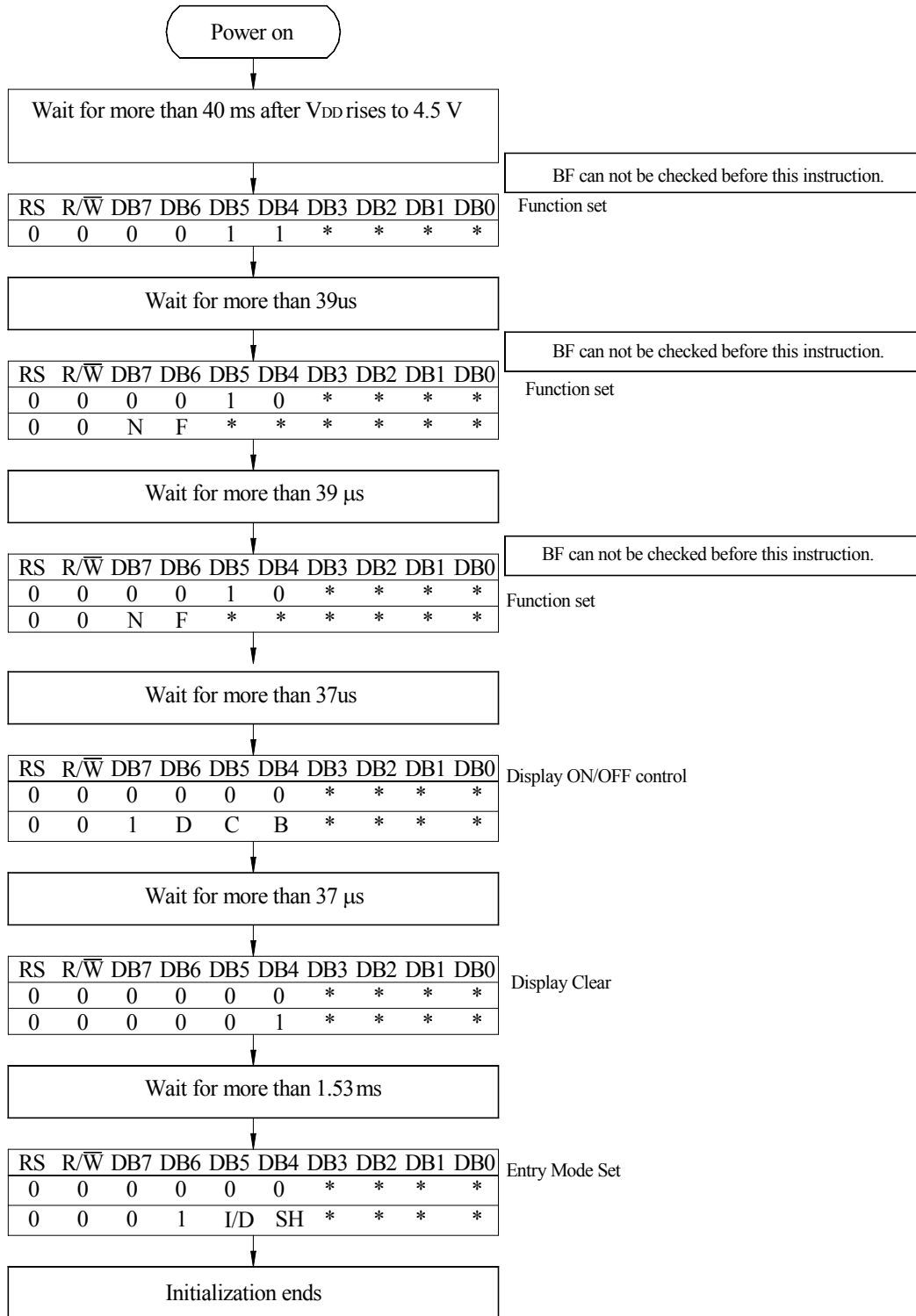

4-Bit Ineterface

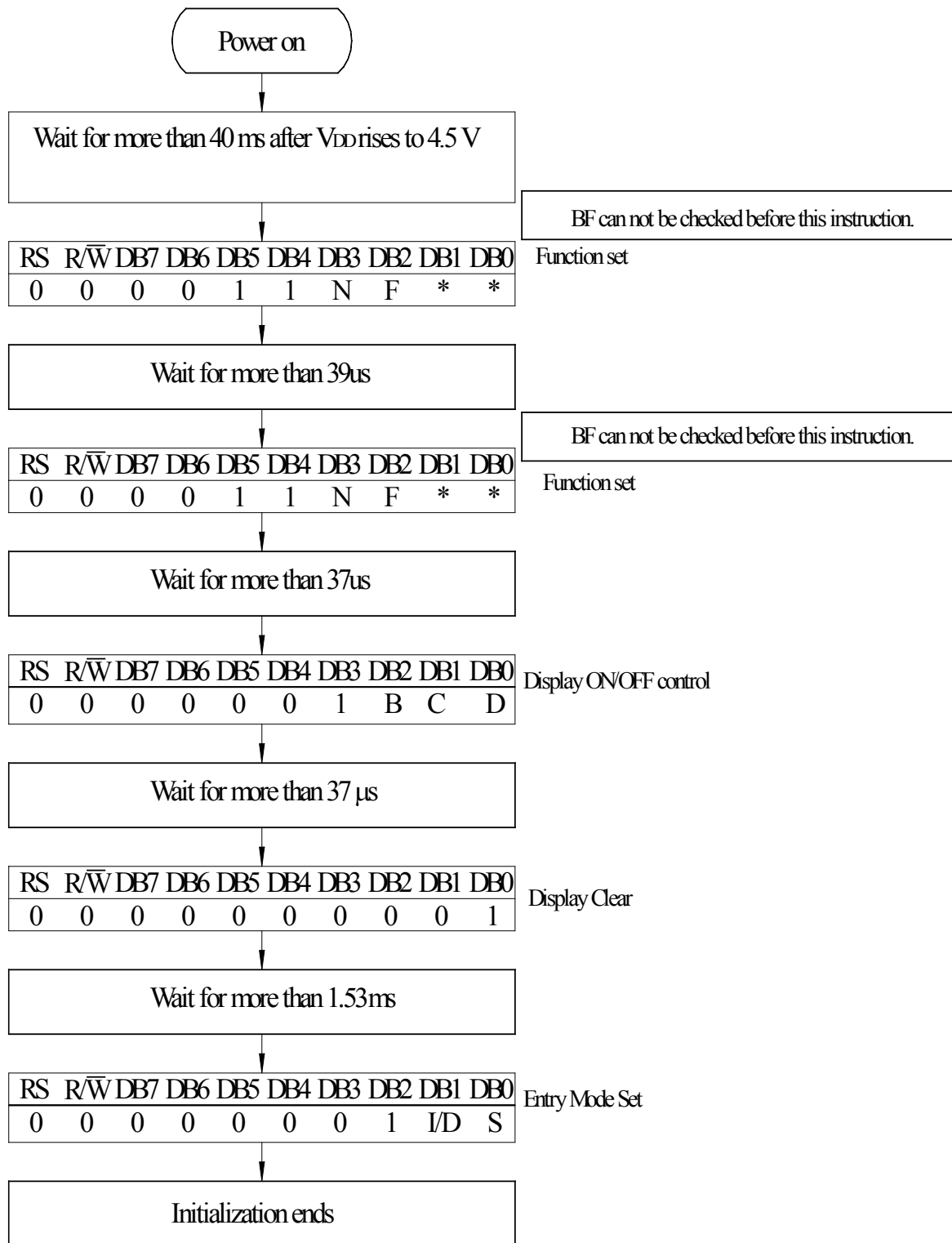

8-Bit Interface

14. Reliability

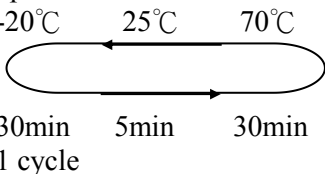
| Environmental Test | | | |
|---|---|--|------|
| Test Item | Content of Test | Test Condition | Note |
| High Temperature storage | Endurance test applying the high storage temperature for a long time. | 80°C 200hrs | 2 |
| Low Temperature storage | Endurance test applying the high storage temperature for a long time. | -30°C 200hrs | 1,2 |
| High Temperature Operation | Endurance test applying the electric stress (Voltage & Current) and the thermal stress to the element for a long time. | 70°C 200hrs | — |
| Low Temperature Operation | Endurance test applying the electric stress under low temperature for a long time. | -20°C 200hrs | 1 |
| High Temperature/ Humidity Operation | The module should be allowed to stand at 60 °C,90%RH max For 96hrs under no-load condition excluding the polarizer, Then taking it out and drying it at normal temperature. | 60°C,90%RH 96hrs | 1,2 |
| Thermal shock resistance | The sample should be allowed stand the following 10 cycles of operation  <p>30min 5min 30min 1 cycle</p> | -20°C/70°C 10 cycles | — |
| Vibration test | Endurance test applying the vibration during transportation and using. | Total fixed amplitude : 1.5mm Vibration Frequency : 10~55Hz One cycle 60 seconds to 3 directions of X,Y,Z for Each 15 minutes | 3 |
| Static electricity test | Endurance test applying the electric stress to the terminal. | VS=800V,RS=1.5kΩ CS=100pF 1 time | — |

Content of Reliability Test (wide temperature, -20°C~70°C)

Note1: No dew condensation to be observed.

Note2: The function test shall be conducted after 4 hours storage at the normal Temperature and humidity after remove from the test chamber.

Note3: Vibration test will be conducted to the product itself without putting it in a container.

15.Backlight Information

Specification

| PARAMETER | SYMBOL | MIN | TYP | MAX | UNIT | TEST CONDITION |
|--------------------|------------------|-----|-----|-----|-------------------|---------------------------------|
| Supply Current | I _{LED} | 30 | 32 | 40 | mA | V=5.0V |
| Supply Voltage | V | 4.5 | 5.0 | 5.4 | V | — |
| Reverse Voltage | V _R | — | — | 5 | V | — |
| Luminous Intensity | I _V | 80 | — | — | CD/M ² | I _{LED} =32mA |
| Life Time | — | — | 50K | — | Hr. | I _{LED} ≤ 32mA Ta=25°C |
| Color | WHITE | | | | | |

Note: The LED of B/L is drive by current only, drive voltage is for reference only. drive voltage can make driving current under safety area (current between minimum and maximum).

2.Drive from pin15,pin16

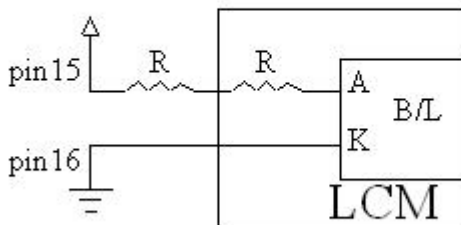

(Will never get V_{ee} output from pin15)

16. Inspection specification

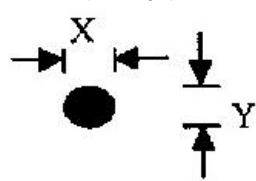
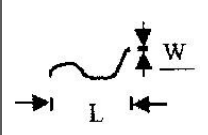
| NO | Item | Criterion | AQL | | | | | | | | | | | | |
|---|---|---|-----------------|-----------------|------------------|-----------------|-------------------------|----------------------|-------------------------|--------------|----------------------|-----|------------|---------------|-----|
| 01 | Electrical Testing | 1.1 Missing vertical, horizontal segment, segment contrast defect. 1.2 Missing character , dot or icon. 1.3 Display malfunction. 1.4 No function or no display. 1.5 Current consumption exceeds product specifications. 1.6 LCD viewing angle defect. 1.7 Mixed product types. 1.8 Contrast defect. | 0.65 | | | | | | | | | | | | |
| 02 | Black or white spots on LCD (display only) | 2.1 White and black spots on display $\leq 0.25\text{mm}$, no more than three white or black spots present. 2.2 Densely spaced: No more than two spots or lines within 3mm | 2.5 | | | | | | | | | | | | |
| 03 | LCD black spots, white spots, contamination (non-display) | 3.1 Round type : As following drawing $\Phi = (x + y) / 2$  <table border="1"> <thead> <tr> <th>SIZE</th> <th>Acceptable Q TY</th> </tr> </thead> <tbody> <tr> <td>$\Phi \leq 0.10$</td> <td>Accept no dense</td> </tr> <tr> <td>$0.10 < \Phi \leq 0.20$</td> <td>2</td> </tr> <tr> <td>$0.20 < \Phi \leq 0.25$</td> <td>1</td> </tr> <tr> <td>$0.25 < \Phi$</td> <td>0</td> </tr> </tbody> </table> | SIZE | Acceptable Q TY | $\Phi \leq 0.10$ | Accept no dense | $0.10 < \Phi \leq 0.20$ | 2 | $0.20 < \Phi \leq 0.25$ | 1 | $0.25 < \Phi$ | 0 | 2.5 | | |
| | | SIZE | Acceptable Q TY | | | | | | | | | | | | |
| $\Phi \leq 0.10$ | Accept no dense | | | | | | | | | | | | | | |
| $0.10 < \Phi \leq 0.20$ | 2 | | | | | | | | | | | | | | |
| $0.20 < \Phi \leq 0.25$ | 1 | | | | | | | | | | | | | | |
| $0.25 < \Phi$ | 0 | | | | | | | | | | | | | | |
| 3.2 Line type : (As following drawing)  <table border="1"> <thead> <tr> <th>Length</th> <th>Width</th> <th>Acceptable Q TY</th> </tr> </thead> <tbody> <tr> <td>---</td> <td>$W \leq 0.02$</td> <td>Accept no dense</td> </tr> <tr> <td>$L \leq 3.0$</td> <td>$0.02 < W \leq 0.03$</td> <td rowspan="2">2</td> </tr> <tr> <td>$L \leq 2.5$</td> <td>$0.03 < W \leq 0.05$</td> </tr> <tr> <td>---</td> <td>$0.05 < W$</td> <td>As round type</td> </tr> </tbody> </table> | Length | Width | Acceptable Q TY | --- | $W \leq 0.02$ | Accept no dense | $L \leq 3.0$ | $0.02 < W \leq 0.03$ | 2 | $L \leq 2.5$ | $0.03 < W \leq 0.05$ | --- | $0.05 < W$ | As round type | 2.5 |
| Length | Width | Acceptable Q TY | | | | | | | | | | | | | |
| --- | $W \leq 0.02$ | Accept no dense | | | | | | | | | | | | | |
| $L \leq 3.0$ | $0.02 < W \leq 0.03$ | 2 | | | | | | | | | | | | | |
| $L \leq 2.5$ | $0.03 < W \leq 0.05$ | | | | | | | | | | | | | | |
| --- | $0.05 < W$ | As round type | | | | | | | | | | | | | |
| 04 | Polarizer bubbles | If bubbles are visible, judge using black spot specifications, not easy to find, must check in specify direction. <table border="1"> <thead> <tr> <th>Size Φ</th> <th>Acceptable Q TY</th> </tr> </thead> <tbody> <tr> <td>$\Phi \leq 0.20$</td> <td>Accept no dense</td> </tr> <tr> <td>$0.20 < \Phi \leq 0.50$</td> <td>3</td> </tr> <tr> <td>$0.50 < \Phi \leq 1.00$</td> <td>2</td> </tr> <tr> <td>$1.00 < \Phi$</td> <td>0</td> </tr> <tr> <td>Total Q TY</td> <td>3</td> </tr> </tbody> </table> | Size Φ | Acceptable Q TY | $\Phi \leq 0.20$ | Accept no dense | $0.20 < \Phi \leq 0.50$ | 3 | $0.50 < \Phi \leq 1.00$ | 2 | $1.00 < \Phi$ | 0 | Total Q TY | 3 | 2.5 |
| Size Φ | Acceptable Q TY | | | | | | | | | | | | | | |
| $\Phi \leq 0.20$ | Accept no dense | | | | | | | | | | | | | | |
| $0.20 < \Phi \leq 0.50$ | 3 | | | | | | | | | | | | | | |
| $0.50 < \Phi \leq 1.00$ | 2 | | | | | | | | | | | | | | |
| $1.00 < \Phi$ | 0 | | | | | | | | | | | | | | |
| Total Q TY | 3 | | | | | | | | | | | | | | |

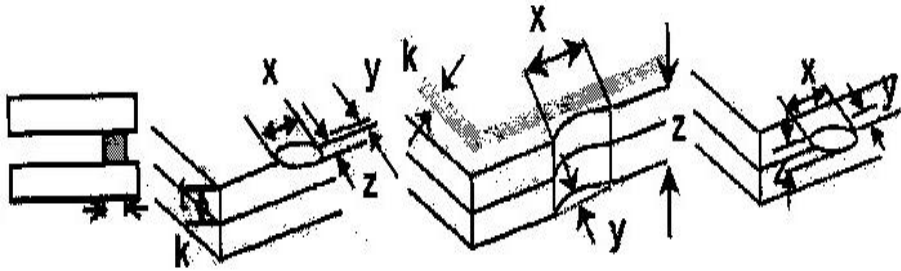
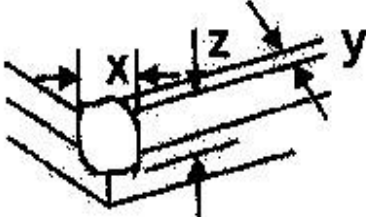
| NO | Item | Criterion | AQL | | | | | | | | | | | | | | | | | | |
|--------------------|-----------------------|---|-------------------|---------------|----------------|---------------|-----------------------|---------------|--------------------|-----------------|---------------|-------------------|---------------|----------------|---------------|-----------------------|---------------|--------------------|-----------------|---------------|-----|
| 05 | Scratches | Follow NO.3 LCD black spots, white spots, contamination | | | | | | | | | | | | | | | | | | | |
| 06 | Chipped glass | <p>Symbols Define: x: Chip length y: Chip width z: Chip thickness k: Seal width t: Glass thickness a: LCD side length L: Electrode pad length:</p> <p>6.1 General glass chip : 6.1.1 Chip on panel surface and crack between panels:</p>  <table border="1" data-bbox="395 1003 1305 1167"> <thead> <tr> <th>z: Chip thickness</th> <th>y: Chip width</th> <th>x: Chip length</th> </tr> </thead> <tbody> <tr> <td>$Z \leq 1/2t$</td> <td>Not over viewing area</td> <td>$x \leq 1/8a$</td> </tr> <tr> <td>$1/2t < z \leq 2t$</td> <td>Not exceed 1/3k</td> <td>$x \leq 1/8a$</td> </tr> </tbody> </table> <p>⊙ If there are 2 or more chips, x is total length of each chip.</p> <p>6.1.2 Corner crack:</p>  <table border="1" data-bbox="395 1554 1305 1718"> <thead> <tr> <th>z: Chip thickness</th> <th>y: Chip width</th> <th>x: Chip length</th> </tr> </thead> <tbody> <tr> <td>$Z \leq 1/2t$</td> <td>Not over viewing area</td> <td>$x \leq 1/8a$</td> </tr> <tr> <td>$1/2t < z \leq 2t$</td> <td>Not exceed 1/3k</td> <td>$x \leq 1/8a$</td> </tr> </tbody> </table> <p>⊙ If there are 2 or more chips, x is the total length of each chip.</p> | z: Chip thickness | y: Chip width | x: Chip length | $Z \leq 1/2t$ | Not over viewing area | $x \leq 1/8a$ | $1/2t < z \leq 2t$ | Not exceed 1/3k | $x \leq 1/8a$ | z: Chip thickness | y: Chip width | x: Chip length | $Z \leq 1/2t$ | Not over viewing area | $x \leq 1/8a$ | $1/2t < z \leq 2t$ | Not exceed 1/3k | $x \leq 1/8a$ | 2.5 |
| z: Chip thickness | y: Chip width | x: Chip length | | | | | | | | | | | | | | | | | | | |
| $Z \leq 1/2t$ | Not over viewing area | $x \leq 1/8a$ | | | | | | | | | | | | | | | | | | | |
| $1/2t < z \leq 2t$ | Not exceed 1/3k | $x \leq 1/8a$ | | | | | | | | | | | | | | | | | | | |
| z: Chip thickness | y: Chip width | x: Chip length | | | | | | | | | | | | | | | | | | | |
| $Z \leq 1/2t$ | Not over viewing area | $x \leq 1/8a$ | | | | | | | | | | | | | | | | | | | |
| $1/2t < z \leq 2t$ | Not exceed 1/3k | $x \leq 1/8a$ | | | | | | | | | | | | | | | | | | | |

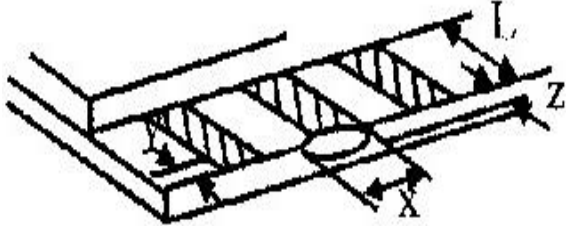
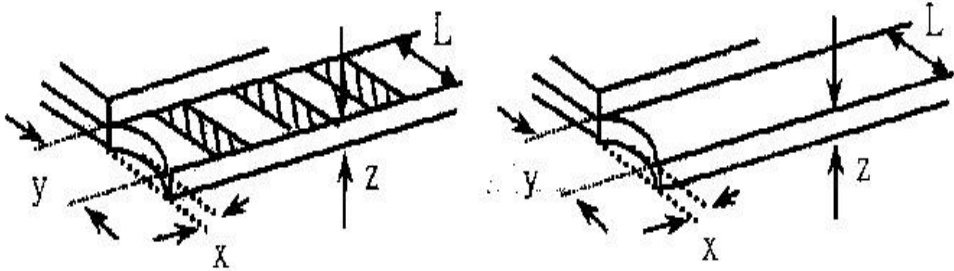
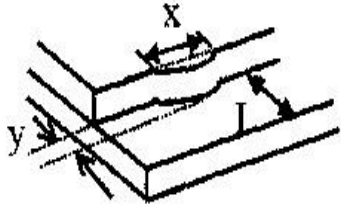
| NO | Item | Criterion | AQL | | | | | | | |
|---|----------------|---|-------------------|-------------------|-------------------|-----------------------|---------------|----------------|---------------|------------|
| 06 | Glass crack | <p>Symbols :</p> <p>x: Chip length y: Chip width z: Chip thickness</p> <p>k: Seal width t: Glass thickness a: LCD side length</p> <p>L: Electrode pad length</p> <p>6.2 Protrusion over terminal :</p> <p>6.2.1 Chip on electrode pad :</p>  <table border="1" data-bbox="304 804 1219 947"> <tr> <td>y: Chip width</td> <td>x: Chip length</td> <td>z: Chip thickness</td> </tr> <tr> <td>$y \leq 0.5\text{mm}$</td> <td>$x \leq 1/8a$</td> <td>$0 < z \leq t$</td> </tr> </table> | y: Chip width | x: Chip length | z: Chip thickness | $y \leq 0.5\text{mm}$ | $x \leq 1/8a$ | $0 < z \leq t$ | 2.5 | |
| | | y: Chip width | x: Chip length | z: Chip thickness | | | | | | |
| $y \leq 0.5\text{mm}$ | $x \leq 1/8a$ | $0 < z \leq t$ | | | | | | | | |
| <p>6.2.2 Non-conductive portion:</p>  <table border="1" data-bbox="376 1279 1219 1420"> <tr> <td>y: Chip width</td> <td>x: Chip length</td> <td>z: Chip thickness</td> </tr> <tr> <td>$y \leq L$</td> <td>$x \leq 1/8a$</td> <td>$0 < z \leq t$</td> </tr> </table> <p>⊙ If the chipped area touches the ITO terminal, over 2/3 of the ITO must remain and be inspected according to electrode terminal specifications.</p> <p>⊙ If the product will be heat sealed by the customer, the alignment mark not be damaged.</p> <p>6.2.3 Substrate protuberance and internal crack.</p>  <table border="1" data-bbox="715 1644 1222 1787"> <tr> <td>y: width</td> <td>x: length</td> </tr> <tr> <td>$y \leq 1/3L$</td> <td>$x \leq a$</td> </tr> </table> | y: Chip width | x: Chip length | z: Chip thickness | $y \leq L$ | $x \leq 1/8a$ | $0 < z \leq t$ | y: width | x: length | $y \leq 1/3L$ | $x \leq a$ |
| y: Chip width | x: Chip length | z: Chip thickness | | | | | | | | |
| $y \leq L$ | $x \leq 1/8a$ | $0 < z \leq t$ | | | | | | | | |
| y: width | x: length | | | | | | | | | |
| $y \leq 1/3L$ | $x \leq a$ | | | | | | | | | |

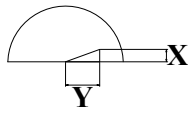
| NO | Item | Criterion | AQL |
|----|--------------------|---|--|
| 07 | Cracked glass | The LCD with extensive crack is not acceptable. | 2.5 |
| 08 | Backlight elements | 8.1 Illumination source flickers when lit. 8.2 Spots or scratched that appear when lit must be judged. Using LCD spot, lines and contamination standards. 8.3 Backlight doesn't light or color wrong. | 0.65 2.5 0.65 |
| 09 | Bezel | 9.1 Bezel may not have rust, be deformed or have fingerprints, stains or other contamination. 9.2 Bezel must comply with job specifications. | 2.5 0.65 |
| 10 | PCB、COB | 10.1 COB seal may not have pinholes larger than 0.2mm or contamination. 10.2 COB seal surface may not have pinholes through to the IC. 10.3 The height of the COB should not exceed the height indicated in the assembly diagram. 10.4 There may not be more than 2mm of sealant outside the seal area on the PCB. And there should be no more than three places. 10.5 No oxidation or contamination PCB terminals. 10.6 Parts on PCB must be the same as on the production characteristic chart. There should be no wrong parts, missing parts or excess parts. 10.7 The jumper on the PCB should conform to the product characteristic chart. 10.8 If solder gets on bezel tab pads, LED pad, zebra pad or screw hold pad, make sure it is smoothed down. 10.9 The Scraping testing standard for Copper Coating of PCB  $X * Y \leq 2\text{mm}^2$ | 2.5 2.5 0.65 2.5 2.5 0.65 0.65 2.5 2.5 |
| 11 | Soldering | 11.1 No un-melted solder paste may be present on the PCB. 11.2 No cold solder joints, missing solder connections, oxidation or icicle. 11.3 No residue or solder balls on PCB. 11.4 No short circuits in components on PCB. | 2.5 2.5 2.5 0.65 |

| NO | Item | Criterion | AQL |
|----|--------------------|---|------|
| 12 | General appearance | 12.1 No oxidation, contamination, curves or, bends on interface Pin (OLB) of TCP. | 2.5 |
| | | 12.2 No cracks on interface pin (OLB) of TCP. | 0.65 |
| | | 12.3 No contamination, solder residue or solder balls on product. | 2.5 |
| | | 12.4 The IC on the TCP may not be damaged, circuits. | 2.5 |
| | | 12.5 The uppermost edge of the protective strip on the interface pin must be present or look as if it cause the interface pin to sever. | 2.5 |
| | | 12.6 The residual rosin or tin oil of soldering (component or chip component) is not burned into brown or black color. | 2.5 |
| | | 12.7 Sealant on top of the ITO circuit has not hardened. | 0.65 |
| | | 12.8 Pin type must match type in specification sheet. | 0.65 |
| | | 12.9 LCD pin loose or missing pins. | 0.65 |
| | | 12.10 Product packaging must the same as specified on packaging specification sheet. | 0.65 |
| | | 12.11 Product dimension and structure must conform to product specification sheet. | |

17. Material List of Components for RoHs

1. HZY Display Co., Ltd hereby declares that all of or part of products (with the mark “#”in code), including, but not limited to, the LCM, accessories or packages, manufactured and/or delivered to your company (including your subsidiaries and affiliated company) directly or indirectly by our company (including our subsidiaries or affiliated companies) do not intentionally contain any of the substances listed in all applicable EU directives and regulations, including the following substances.

Exhibit A : The Harmful Material List

| Material | (Cd) | (Pb) | (Hg) | (Cr6+) | PBBs | PBDEs |
|--|---------|----------|----------|----------|----------|----------|
| Limited Value | 100 ppm | 1000 ppm | 1000 ppm | 1000 ppm | 1000 ppm | 1000 ppm |
| Above limited value is set up according to RoHS. | | | | | | |

2.Process for RoHS requirement :

(1) Use the Sn/Ag/Cu soldering surface ; the surface of Pb-free solder is rougher than we used before.

(2) Heat-resistance temp. :

Reflow : 250°C,30 seconds Max. ;

Connector soldering wave or hand soldering : 320°C, 10 seconds max.

(3) Temp. curve of reflow, max. Temp. : 235±5°C ;

Recommended customer’s soldering temp. of connector : 280°C, 3 seconds.