



# DOT MATRIX LIQUID CRYSTAL DISPLAY MODULE

**COMPANY NAME : Mc'Tronic**

## **USER'MANUAL**

*SG19264A0 Serial*

**LCD Module Description: SGS19264A0JEW02**

PROPOSED BY		APPROVED
Design	Approved	
		

Sample Delivery Date:2017.11.20 (Ver.2017.11.22)

### ***SDEC TECHNOLOGY CORP.***

***ADDRESS: 10F, No. 98, Shing De Rd., Sanchong Dist. 241  
New Taipei City, Taiwan R.O.C.***

***TEL: 886-2-2999-2512/886-2-8512-1288***

***FAX: 886-2-2999-2510/886-2-8512-2828***

***EMAIL:sdec8405@ms6.hinet.net/sdec@sdec.com.tw***

***<http://www.sdec.com.tw>***



## LCM SAMPLE APPROVAL

(液晶顯示模組樣品確認書)

1 · PART A: FILLED BY SDEC TECH (由 SDEC 填寫)

- 1) COMPANY NAME (客戶名稱) : Mc'Tronic
- 2) SDEC ITEM NO. (產品型號) : SGS19264A0JEW02
- 3) CUSTOMER ITEM NO. (客戶產品型號) : DS11004711
- 4) LCM Function (LCM 內容) :

A	LCD TYPE (LCD 種類) : <input type="checkbox"/> TN, <input type="checkbox"/> HTN, <input checked="" type="checkbox"/> STN, <input type="checkbox"/> FSTN, <input type="checkbox"/> DFSTN ( <input type="checkbox"/> POSITIVE/正向, <input checked="" type="checkbox"/> NEGATIVE/反向, <input type="checkbox"/> BLACK MASK/內黑絲印)
B	VIEWING AREA (視角方向) : <input type="checkbox"/> 3H, <input checked="" type="checkbox"/> 6H, <input type="checkbox"/> 9H, <input type="checkbox"/> 12H
C	POLARIZER COLOR (偏光板顏色) : <input type="checkbox"/> GRAY/灰色, <input type="checkbox"/> YELLOW GREEN/黃綠色, <input checked="" type="checkbox"/> BLUE/藍色, <input type="checkbox"/> BLACK/黑色
D	BACKLIGHT COLOR (背光顏色) : <input type="checkbox"/> YELLOW GREEN/黃綠光, <input type="checkbox"/> ORANGE/橘光 <input type="checkbox"/> AMBER/琥珀光, <input type="checkbox"/> RED/紅光, <input type="checkbox"/> BLUE/藍光, <input type="checkbox"/> GREEN/翠綠光, <input checked="" type="checkbox"/> WHITE/白光, <input type="checkbox"/> WHITE(Patent)/專利白光, <input type="checkbox"/> DOUBLE COLOR/雙色光, <input type="checkbox"/> RGB/三色光
E	JUMPER : <input checked="" type="checkbox"/> JA <input checked="" type="checkbox"/> JK <input type="checkbox"/> J1 <input checked="" type="checkbox"/> J2
F	TEMPERATURE (溫度) : <input type="checkbox"/> NORMAL/常溫, <input checked="" type="checkbox"/> WIDE/廣溫
G	CONTROL IC (控制 IC) : NT7108C

SAMPLE DELIVERY DATE (出樣日期) : 2017.11.20

2 · PART B: FILLED BY CUSTOMER (請客戶填寫)

CHECK LIST ITEMS (檢查項目) :	O K	N G	REASON (原因)
1).LCM SIZE AND THICKNESS:(LCM 尺寸及厚度):	<input type="checkbox"/>	<input type="checkbox"/>	_____
2).POLARIZER COLOR : (偏光板色澤) :	<input type="checkbox"/>	<input type="checkbox"/>	_____
3).ELECTRO CHARACTERISTIC : (電氣特性) :	<input type="checkbox"/>	<input type="checkbox"/>	_____
4).VIEWING AREA (視角範圍) :	<input type="checkbox"/>	<input type="checkbox"/>	_____
5).BACKLIGHT ILLIMINATION (背光亮亮度) :	<input type="checkbox"/>	<input type="checkbox"/>	_____
6).TEMPERATURE RANGE (溫度範圍) :	<input type="checkbox"/>	<input type="checkbox"/>	_____

APPROVED BY (批准) :

DATE OF APPROVAL (批准日期) :



## REVISION RECORD

Revision	Page	Contents
2017.11.20	2	Sample Delivery Date
	6	Block Diagram Add Jump Circuit
	16	Add 18. Processing Diagram
2017.11.22	2	Add Customer Item No: DS11004711

# SDEC LCD Module Numbering System

1	2	3	4	5	6	7	8	9	10	11	12	13	14	15
S	C	S		040			04		A0	H	L	T	I	0
S	G	F		320			24		A0	J	C	W	I	0
S	D	H		007			08		A0	B	N	N	0	0

Numbering System	Code Value	Description	Remark	
1	Company	S	S Company name abbreviated	SDEC CO.,LTD
2	LCM type	G	B C G O T S D B:Big Character C:Character G:Graphic O:COG T:TAB S:Seven Segment D:Customer Design	LCM type
3	LCD type	S	T H S F D R M V A L TN type LCD HTN type LCD STN type LCD FSTN type LCD DFSTN type LCD Color TN / Color STN TFT LCD VFD VATN OLED	LCD type
4,5,6	Row dots number Characters per line Year	128	122,128,240,320... 008,016,020,040... 006,007...	Graphic Character Seven Segment
7,8	Column dots number Lines Month	64	32,64,128,240... 01,02,04... 01,02..12	Graphic Character Seven Segment
9,10	LCD module serial number	A0	A0~ZZ	Ux -> USB Port Interface Sx -> Series Port Interface Rx -> RS-232 Port Interface
11	Polarizer Color & Viewing angle type	I	A B C D E F G H I J K L M Gray Mode/3:00view Gray Mode/6:00view Gray Mode/9:00view Gray Mode/12:00view Yellow Green Mode/3:00view Yellow Green Mode/6:00view Yellow Green Mode/9:00view Yellow Green Mode/12:00view Negative type/3:00view Negative type/6:00view Negative type/9:00view Negative type/12:00view Other	Polarizer Color & Viewing angle type
12	Backlight type	L	N L E C F Without backlight Array LED Edge LED C.C.F.L EL	Backlight type
13	Backlight color (VFD color)	Y	N O A B G R Y W P D T Without backlight Orange Amber Blue Green Red Yellow-green White White(Patent) Double Color(Y-G&R) R G B	Backlight color
14	Font Code Type	0	0 1 2 3 A B C F U Z No Font Table English-Japanese Font Code English-Europe Font Code English-Russian Font Code BIG-5 Chinese Font Code GB Chinese Font Code ST7920-0C Font Code ST7920-0F Font code (Korean) Unicode Other Font Code	Font Table Code Type
15	Series Code	0	0~Z	Series Code

**CONTENTS**

	<b>PAGE</b>
● <b>LCM Sample Approval</b>	<b>2</b>
● <b>REVISION RECORD</b>	<b>3</b>
● <b>LCD Module Number System</b>	<b>4</b>
<b>1. Mechanical Specification</b>	<b>6</b>
<b>2. Mechanical Diagram</b>	<b>6</b>
<b>3. Interface Pin Connections</b>	<b>6</b>
<b>4. Block And Power Supper Diagram</b>	<b>6</b>
<b>5. Electrical Absolute Maximum Ratings</b>	<b>7</b>
<b>6. Electrical Characteristics</b>	<b>7</b>
<b>7. Optical Characteristics</b>	<b>7</b>
<b>8. Optical Definitions</b>	<b>7</b>
<b>9. Timing Control</b>	<b>7</b>
<b>10. Initialization And Programming</b>	<b>8</b>
<b>11. Instruction Set</b>	<b>8</b>
<b>12. Description Of Instructions</b>	<b>8</b>
<b>13. Functional Test &amp; Inspection Criteria</b>	<b>10</b>
<b>14. Reliability Test – Normal Temperature</b>	<b>12</b>
<b>15. Reliability Test – Wide Temperature</b>	<b>13</b>
<b>16. Precautions Against Product Handling</b>	<b>14</b>
<b>17. Warranty</b>	<b>15</b>
<b>18. Processing Diagram</b>	<b>16</b>

## 1. Mechanical Specification

ITEM	STANDARD VALUE			UNIT
DOT MATRIX FORMAT	192 X 64 DOTS			--
MODULE DIMENSION	130.0 (W) X 65.0 (H) X 12.5 (T)			mm
VIEWING DISPLAY AREA	104.0 (W) X 39.0 (H)			mm
ACTIVE DISPLAY AREA	95.95 (W) X 31.95 (H)			mm
DOT SIZE	0.45 (W) X 0.45 (H)			mm
DOT PITCH	0.50 (W) X 0.50 (H)			mm
● EDGE LED BACKLIGHT COLOR	WHITE			
BACKLIGHT INPUT	DC +4.0 (Type)	V	78 (Type)	mA
BACKLIGHT LIFE TIME	20,000 (AVOID LIGHTING CONTINUOUSLY · Ta=25°C)			HR.

## 2. Mechanical Diagram

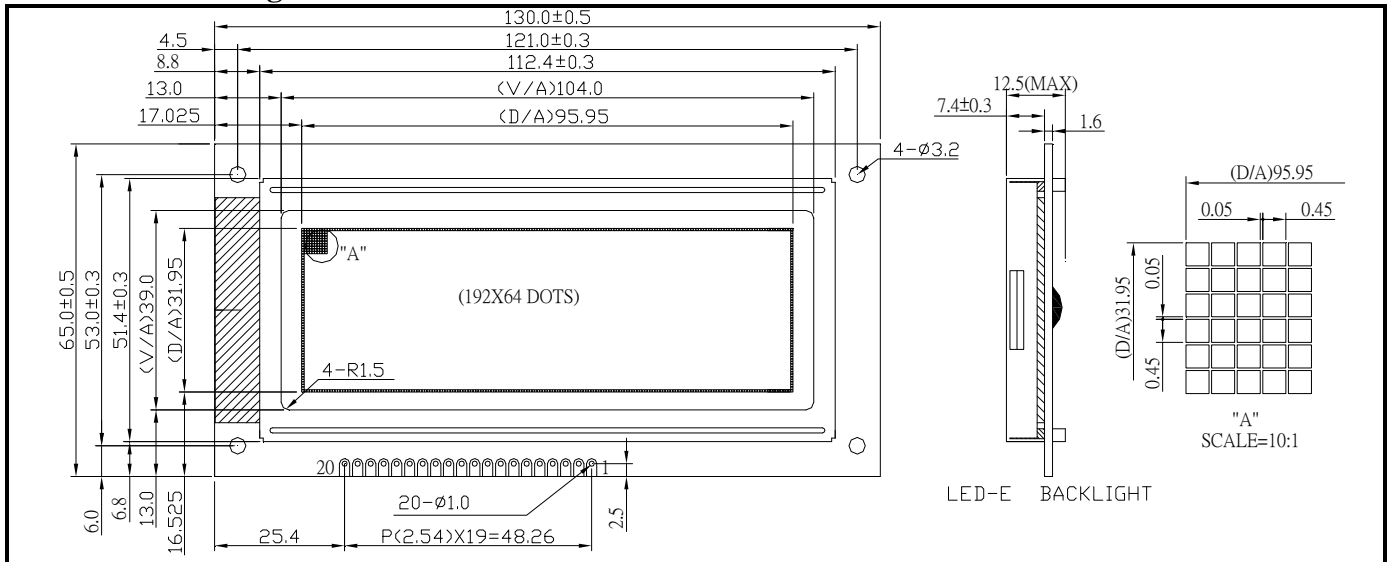

## 3. Interface Pin Connections

NO	SYMBOL	LEVEL	FUNCTION
1	VSS	--	GND ( 0V)
2	VDD	--	DC +5V
3	VO	--	Contrast Adjust
4	RS	H/L	Data / Instruction code
5	R/W	H/L	Read / Write
6	E	H,H→L	Enable signal
7	DB0	H/L	Data Bit 0
8	DB1	H/L	Data Bit 1
9	DB2	H/L	Data Bit 2
10	DB3	H/L	Data Bit 3
11	DB4	H/L	Data Bit 4
12	DB5	H/L	Data Bit 5
13	DB6	H/L	Data Bit 6
14	DB7	H/L	Data Bit 7
15	/CS1	L	Chip 1 enable signal
16	/RST	L	Reset signal
17	/CS2	L	Chip 2 enable signal
18	/CS3	L	Chip 3 enable signal
19	VEE	DC -5V	Negative voltage output
20	LED(+)	+5.0V	LED backlight +

## 4. Block And Power Supply Diagram

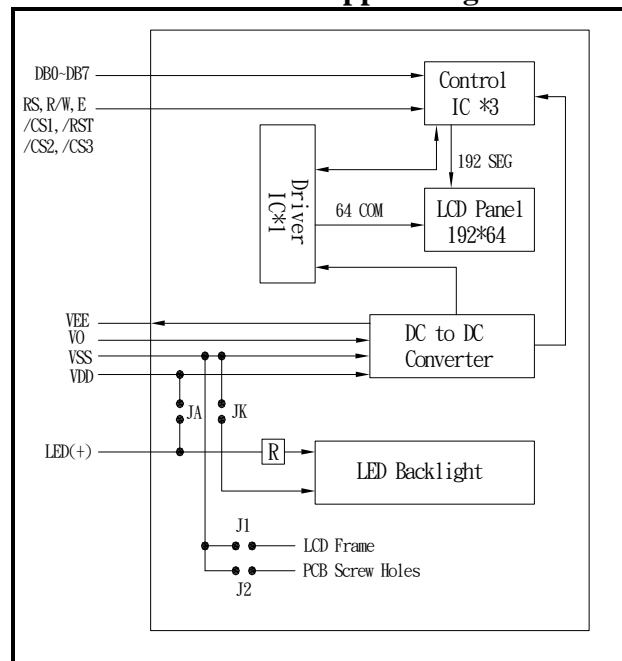

5. Environmental absolute maximum ratings

ITEM	OPERATING		STORAGE		REMARKS
	MIN.	MAX.	MIN.	MAX.	
Ambient Temperature	-20°C	+70 °C	-30 °C	+80 °C	NOTE 1
Humidity	NOTE 1		NOTE 2		Without Condensation
Vibration	--	4.9m/s <sup>2</sup>	--	19.6m/s <sup>2</sup>	XYZ Directions
Shock	--	29.4m/s <sup>2</sup>	--	490.0m/s <sup>2</sup>	XYZ Directions

Remarks:

NOTE (1) : Ta at 60 °C : 50 HR Max.

NOTE (2) : Ta < 40 °C : 95% RH Max.

Ta > 40 °C : Absolute humidity must be lower than the humidity of 95% at 40 °C.

6. Electrical Characteristics

ITEM	SYN	CONDITION	MIN.	TYPE	MAX.	UNIT
SUPPLY VOLTAGE FOR LOGIC	VDD-VSS	--	4.5	5.0	6.5	V
SUPPLY VOLTAGE FOR LCD	VLCD	Ta= 25°C	8.7	9.0	9.3	V
INPUT HIGH VOLTAGE	VIH	--	2.0	--	VDD	V
INPUT LOW VOLTAGE	VIL	--	0	--	0.8	V
SUPPLY CURRENT (LOGIC)	IDD	VDD=+5V, VEE=-5V	--	--	5.0	mA

7. Optical Characteristics

Ta at 25°C

ITEM	SYM	CONDITION	MIN.	TYPE	MAX.	UNIT
VIEW ANGLE (TOP/BOTTOM)	$\theta 1 / \theta 2$	$CR \geq 5$	--	45/35	--	deg.
VIEW ANGLE (LEFT/RIGHT)	$\phi 1 / \phi 2$	$CR \geq 5$	--	35/35	--	deg.
CONTRAST RATIO	CR	--	--	7	--	---
RESPONSE TIME (RISE)	TON/Tr	--	--	160	--	mS
RESPONSE TIME (DECAY)	TOFF/Tf	--	--	210	--	mS

8. Optical Definitions

Response Time

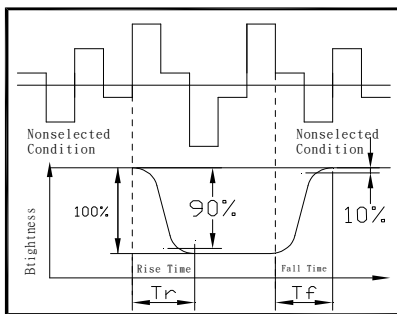

Contrast Ratio

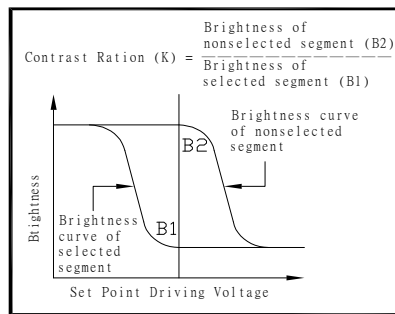

View Angle

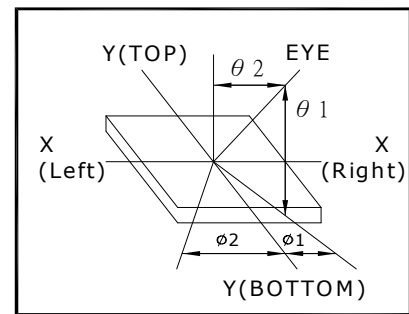

9. Timing Control

Write Operation (NOTE 1)

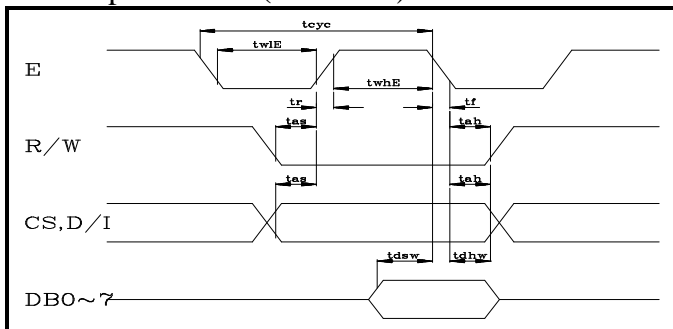

Read Operation (NOTE 2)

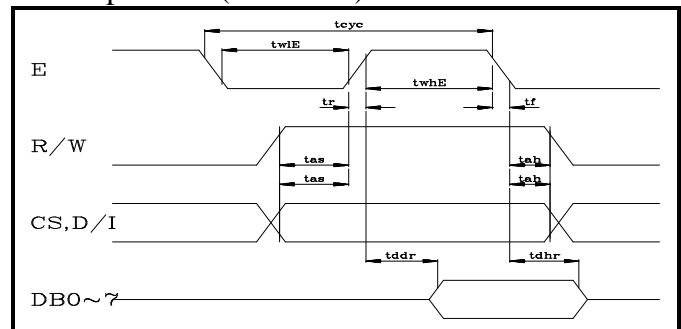

Item	Symbol	Limit (Min.)	Limit (Max.)	Unit
E cycle	tcyc	1000	--	ns
E high level width	twhE	450	--	ns
E low level width	twlE	450	--	ns
E rise time	tr	--	25	ns
E fall time	tf	--	25	ns
Address set-up time	tas	140	--	ns
Address hold time	tah	10	--	ns
Data set-up time	tdsw	200	--	ns
Data delay time	tddr	--	320	ns
Data hold time (write)	tdhw	10	--	ns
Data hold time (read)	tdhr	20	--	ns

### 10. Initialization And Programming

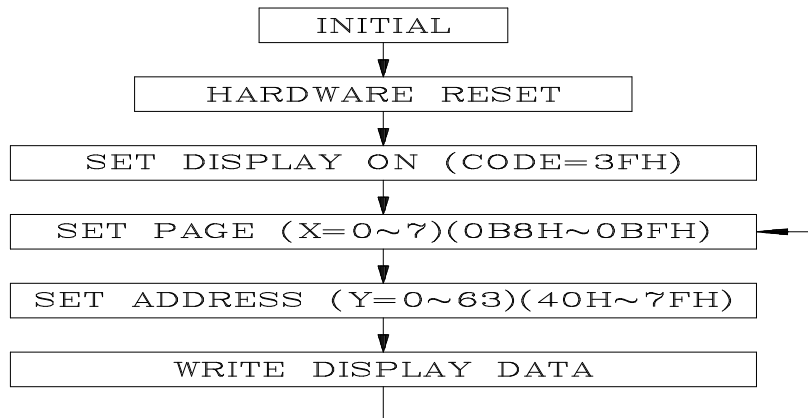

### 11. Instruction Set

FUNCTION	R/W	D/I	DB7	DB6	DB5	DB4	DB3	DB2	DB1	DB0	FUNCTION	
1. Display ON/OFF	0	0	0	0	1	1	1	1	1	1/0	Controls the ON/OFF of the display. RAM data internal status are not affected. 1:ON, 0:OFF.	
2. Display start line	0	0	1	1	display start line ( 0~63 )						Indicates the display data RAM displayed at the top of the screen.	
3. Set page ( X address)	0	0	1	0	1	1	1	page ( 0~7 )			Sets the page (X address) of RAM at the page (X address) register.	
4. Set address	0	0	0	1	Y address ( 0~63 )						Sets the Y address at the Y address counter.	
5. Status Read	1	0	B U S Y	0	ON/ OFF	R E S E T	0	0	0	0	Reads the status. RESET 1:Reset, 0:normal. ON/OFF 1: Display OFF, 0: Display ON. BUSY 1: In operation. 0: Ready	
6. Write Display Data	0	1	Write Data									Writes data (DB0~7) into display data RAM. After writing instruction, Y address is increased by 1 automatically.
7. Read Display Data	1	1	Read Data									Reads data (DB0~7) from display data RAM to the data bus.

### 12. Description Of Instructions

(1) Display ON/OFF

	R/W	D/I	DB7	DB6	DB5	DB4	DB3	DB2	DB1	DB0
Code	0	0	0	0	1	1	1	1	1	D

The display data appears when D is 1 and disappears when D is 0. Though the data is not on the screen width D=0, it remains in the display data RAM. Therefore, you can make it appear by changing D=0 or D=1.

(2) Display start line

	R/W	D/I	DB7	DB6	DB5	DB4	DB3	DB2	DB1	DB0
Code	0	0	1	1	A	A	A	A	A	A

Z address AAAAAA (binary) of the display data RAM is set at the display start line register and displayed at the top of the screen.

(3) Set page (X address)

	R/W	D/I	DB7	DB6	DB5	DB4	DB3	DB2	DB1	DB0
Code	0	0	1	0	1	1	1	A	A	A

X address AAA (binary) of the display data RAM is set at the X address register. After that, writing or from MPU is executed in this specified page until the next page is set.

(4) Set Y address

	R/W	D/I	DB7	DB6	DB5	DB4	DB3	DB2	DB1	DB0
Code	0	0	0	1	A	A	A	A	A	A

Y address AAAAAA (binary) of the display RAM is set at the Y address counter is increase by every time data is written or read to or from MPU.



0 1 2 3 4 5 .....61 62 63

DB0 I DB7	PAGE 0	X=0
DB0 I DB7	PAGE 1	X=1
	:	
DB0 I DB7	PAGE 6	X=6
DB0 I DB7	PAGE 7	X=7

Address Configuration of Display RAM

(5) Status Read

	R/W	D/I	DB7	DB6	DB5	DB4	DB3	DB2	DB1	DB0
Code	1	0	BUSY	0	ON/OFF	RESET	0	0	0	0

**BUSY :** When BUSY is 1, The LSI is in internal operation. No instructions are accepted while BUSY is 1, so you should make sure that BUSY is 0 before writing the next instruction.

**ON/OFF:** This bit show the liquid crystal conditions ON condition or OFF condition.  
When ON/OFF is 1, the display is on OFF condition.  
When ON/OFF is 0, the display on ON condition.

**RESET:** RESET=1 shows that the system is being initialized. In this condition, any instructions except Status Read instruction cannot be accepted.  
RESET=0 shows that initializing has finished and system is in the usual operation.

(6) Write Display Data

	R/W	D/I	DB7	DB6	DB5	DB4	DB3	DB2	DB1	DB0
Code	0	1	D	D	D	D	D	D	D	D

Writes 8-bit data DDDDDDDD (binary) into display data RAM. The Y address is increased by 1 automatically.

(7) Read Display Data

	R/W	D/I	DB7	DB6	DB5	DB4	DB3	DB2	DB1	DB0
Code	1	1	D	D	D	D	D	D	D	D

Reads out 8-bit data DDDDDDDD (binary) from the display data RAM. The Y address is increased by 1 automatically. One dummy read is necessary soon after the address setting.

### 13. Functional Test & Inspection Criteria

#### 13.1 Sample plan

Sample plan according to MIL-STD-105D level 2, and acceptance/rejection criteria is.  
 Base on : Major defect : AQL 0.65 Minor defect : AQL 2.5

#### 13.2 Inspection condition

Viewing distance for cosmetic inspection is 30cm with bare eyes, and under an environment of 800 lus (20W) light intensity. All direction for inspecting the sample should be within 45° against perpendicular line.

#### 13.3 Definition of Inspection Zone in LCD

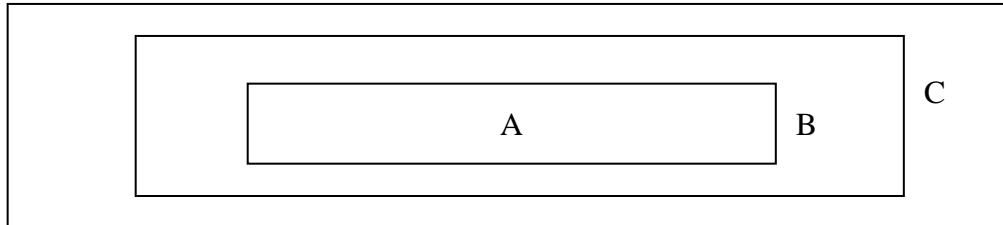

Zone A : Character / Digit area

Zone B : Viewing area except Zone A ( Zone A + Zone B = minimum Viewing area )

Zone C : Outside viewing area ( invisible area after assembly in customer's product )

Note : As a general rule, visual defects in Zone C are permissible, when it is no trouble for quality and assembly of customer's product.

#### 13.4 Major Defect

All functional defects such as open ( or missing segment ), short, contrast differential, excess power consumption, smearing, leakage, etc. and overall outline dimension beyond the drawing. Are classified as major defects.

#### 13.5 Inspection Parameters And Glass Pixel(偏光板和玻璃圖像檢驗)

No	Polarizer (偏光片)	Criteria				
1	Black or White spots and Piercing (黑/白點和刺孔)	Zone		Acceptable number (可接受數量)		
		Dimension (mm)		A	B	C
		D ≤ 0.15		*	*	*
		0.15 < D ≤ 0.2		4	6	*
		0.2 < D ≤ 0.3		2	2	*
		0.3 < D		0	0	*
D[面積]=(Length[長度]+Width[寬度])/2 * : Disregard(忽略)						
2	Scratch (刮傷)	Zone	Zone	Acceptable number (可接受數量)		
		X(mm)	Y(mm)	A	B	C
		*	0.04 ≥ W	*	*	*
		3.0 ≥ L	0.06 ≥ W	4	4	*
		2.0 ≥ L	0.08 ≥ W	2	2	*
		--	0.10 ≥ W	0	0	*
X : Length[長度] Y : Width[寬度] * : Disregard(忽略)						
3	Air Bubbles (between glass & polarizer) 氣泡 (玻璃跟偏光板之間)	Zone		Acceptable number (可接受數量)		
		Dimension (mm)		A	B	C
		D ≤ 0.20		*	*	*
		0.20 < D ≤ 0.50		2	2	*
		0.50 < D		0	0	*
* : Disregard(忽略)						

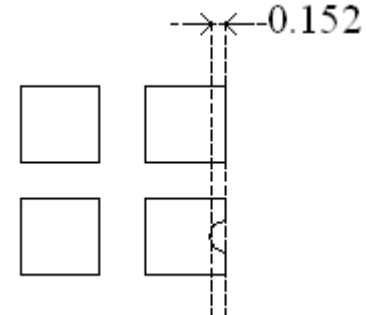
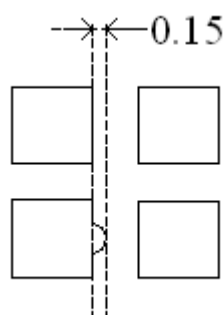
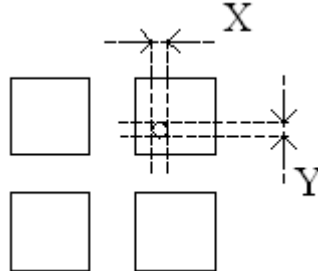
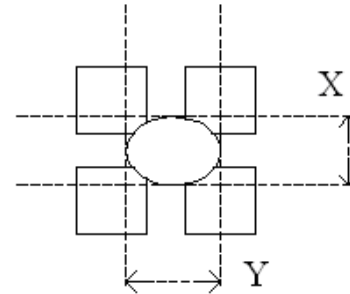
<p>4</p>	<p>Glass of Pixel (玻璃的圖像)</p>	<p>(1)Pixel shape (with Dent)/圖像凹度</p>  <p>•Less than 0.152 mm is no counted (小於 0.152mm 者不計)</p> <p>(2)Pixel shape (with Projection)/圖像凸度</p>  <p>Should not be connected next pixel (點與點間不可先連接)</p> <p>(3)Deformation/變形</p>  <p><math>(X + Y) / 2 \leq 0.15\text{mm}</math> •Less than 0.1 mm is no counted (小於 0.15mm 者不計)</p> <p>(4) Deformation/變形</p>  <p><math>(X + Y) / 2 \leq 0.3\text{mm}</math> •Less than 0.3 mm is no counted (小於 0.3mm 者不計)</p>
----------	-----------------------------------	--

#### 14. Reliability Test (測試條件) – Normal Temperature (常溫)

No change no display and in operation under the following text condition.

(在不改變原先顯示下進行以下測試操作)

Conditions : Unless otherwise specified, test will be conducted under the following condition.

Temperature :  $20\pm 5\text{ }^{\circ}\text{C}$

Humidity :  $40\pm 5\%\text{RH}$

Tests will be not conducted under functioning state.

(條件：除非其他特殊情況，否則測試將以溫度： $20\pm 5\text{ }^{\circ}\text{C}$ ，濕度： $40\pm 5\%\text{RH}$ 為主)

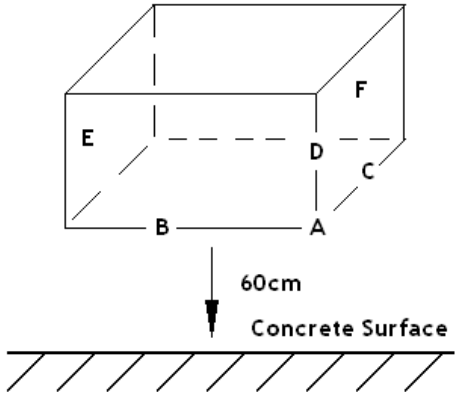
NO	Parameter	Conditions	Notes
1	High Temperature Operating	$50^{\circ}\text{C}\pm 2\text{ }^{\circ}\text{C}$ , 96 hrs (operation state) (96 小時，溫度 $50^{\circ}\text{C}\pm 2\text{ }^{\circ}\text{C}$ 電源開啟的操作情況下)	
2	Low Temperature Operating	$0^{\circ}\text{C}\pm 2\text{ }^{\circ}\text{C}$ , 96 hrs (operation state) (96 小時，溫度 $0^{\circ}\text{C}\pm 2\text{ }^{\circ}\text{C}$ 電源開啟的操作情況下)	1
3	High Temperature Storage	$60^{\circ}\text{C}\pm 2\text{ }^{\circ}\text{C}$ , 96 hrs (96 小時，溫度 $60^{\circ}\text{C}\pm 2\text{ }^{\circ}\text{C}$ 電源關閉靜態操作下)	2
4	Low Temperature Storage	$-10^{\circ}\text{C}\pm 2\text{ }^{\circ}\text{C}$ , 96 hrs (96 小時，溫度 $-10^{\circ}\text{C}\pm 2\text{ }^{\circ}\text{C}$ 電源關閉靜態操作下)	1, 2
5	Damp Proof Test	$40^{\circ}\text{C}\pm 2\text{ }^{\circ}\text{C}$ , 85 ~ 90%RH , 96hr (96 小時，溫度： $40^{\circ}\text{C}\pm 2\text{ }^{\circ}\text{C}$ ，濕度： $85\sim 90\%\text{RH}$ 電源關閉靜態操作下)	1, 2
6	Vibration Test	Total fixed amplitude : 1.5 mm (完全固定輻射：1.5mm) Vibration Frequency : 10 ~ 55 Hz (震動頻率：10~55 Hz) One cycle 60 seconds to 3 directions of X, Y, Z for each 15 minutes (每一個循環 X, Y, Z 軸方向各做 60 秒，連續做 5 次，共計 15 分鐘)	3
7	Shock Test	To be measured after dropping from 60cm high on the concrete surface in packing state. (包裝材從 60 公分高的地方向地面落下)  Dropping method comer dropping (角落落下方式) A comer : once Edge dropping (側邊落下) B, C, D edge : once Face dropping (表面落下) E, F, G face : once	

Note 1 : No dew condensation to be observed. (不要在”水氣凝結點”下觀察)

Note 2 : The function test shall be conducted after 4 hours storage at the normal

Temperature and humidity after removed from the test chamber

(從實驗室移出後，放在一般常溫 (溫度： $25^{\circ}\text{C}$ ，濕度： $45\%\text{RH}$ )，

且四小時後通電流或電壓，看它是否能正常動作)

Note 3 : Vibration test will be conducted to the product itself without putting it in a container.

(在震動測試下，產品本身不需容器即能自行傳導)

**15. Reliability Test (測試條件) – Wide Temperature (廣溫)**

No change no display and in operation under the following text condition.

(在不改變原先顯示下進行以下測試操作)

Conditions : Unless otherwise specified, test will be conducted under the following condition.

Temperature : 20±5 °C

Humidity : 40±5%RH

Tests will be not conducted under functioning state.

(條件：除非其他特殊情況，否則測試將以溫度：20±5 °C，濕度：40±5%RH 為主)

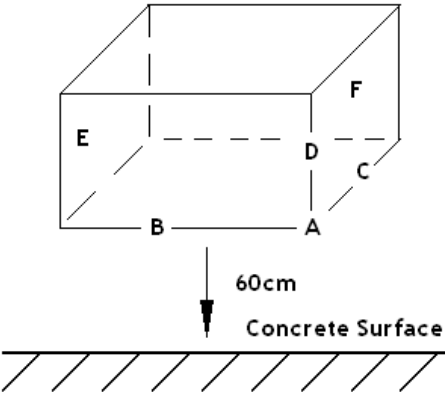
NO	Parameter	Conditions	Notes
1	High Temperature Operating	70°C±2 °C , 96 hrs (operation state) (96 小時，溫度 70°C±2 °C 電源開啟的操作情況下)	
2	Low Temperature Operating	-20°C±2 °C , 96 hrs (operation state) (96 小時，溫度 -20°C±2 °C 電源開啟的操作情況下)	1
3	High Temperature Storage	80°C±2 °C , 96 hrs (96 小時，溫度 80°C±2 °C 電源關閉靜態操作下)	2
4	Low Temperature Storage	-30°C±2 °C , 96 hrs (96 小時，溫度 -30°C±2 °C 電源關閉靜態操作下)	1, 2
5	Damp Proof Test	40°C±2 °C , 85 ~ 90%RH , 96hr (96 小時，溫度：40°C±2 °C，濕度：85~90%RH 電源關閉靜態操作下)	1, 2
6	Vibration Test	Total fixed amplitude : 1.5 mm (完全固定輻射：1.5mm) Vibration Frequency : 10 ~ 55 Hz (震動頻率：10~55 Hz) One cycle 60 seconds to 3 directions of X, Y, Z for each 15 minutes (每一個循環 X, Y, Z 軸方向各做 60 秒，連續做 5 次，共計 15 分鐘)	3
7	Shock Test	To be measured after dropping from 60cm high on the concrete surface in packing state. (包裝材從 60 公分高的地方向地面落下)  Dropping method comer dropping (角落落方式) A comer : once Edge dropping (側邊落下) B, C, D edge : once Face dropping (表面落下) E, F, G face : once	

Note 1 : No dew condensation to be observed. (不要在”水氣凝結點”下觀察)

Note 2 : The function test shall be conducted after 4 hours storage at the normal

Temperature and humidity after removed from the test chamber

(從實驗室移出後，放在一般常溫 (溫度：25°C，濕度：45%RH)，

且四小時後通電流或電壓，看它是否能正常動作)

Note 3 : Vibration test will be conducted to the product itself without putting it in a container.

(在震動測試下，產品本身不需容器即能自行傳導)

## 16. Precautions Against Product Handling [產品使用注意事項]：

The following precautions will guide you in handling our product correctly.

[下列警戒引導正確地使用產品]

### 16.1 Care of the LCD module against static electricity discharge. [LCD 模組靜電注意事項]

16.1.1 When working with the module, be sure to ground your body and any electrical equipment you may be using. We strongly recommend the use of anti static mats (made of rubber), to protect work tables against the hazards of electrical shock.

[操作模組時，避免操作者身體接地及任何造成靜電的設備同時使用，強烈建議(橡膠製)抗靜電墊的使用，以免工作台面遭受到電氣干擾]

16.1.2 Slowly and carefully remove the protective film from the LCD module, since this operation can generate static electricity.

[緩慢小心地移除 LCD 模組上的保護膜，以防靜電產生]

16.1.3 Avoid the use of work clothing made of synthetic fibers. We recommend cotton clothing or other conductivity-treated fibers.

[避免穿著人造合成的工作服，建議棉質或是有傳導性的纖維質料]

### 16.2 Liquid crystal display devices (LCD devices) [液晶螢幕顯示器的組成]

16.2.1 The polarizer adhering to the surface of the LCD is made of a soft material.

Guard against scratching it. [偏光板是軟性原料製成，請勿刮傷]

16.2.2 The LCD device panel used in the LCM is made of plate glass. Avoid any strong mechanical shock. Should the glass break handle it with care.

[模組使用的玻璃為平面玻璃，避免任何強烈的機械撞擊，且觸碰時請小心]

### 16.3 When the LCD module alone must be stored form long periods of time

[當 LCD 模組須長時間存放時]

16.3.1 Protect the modules from excessive external forces. [避免外力壓迫]

16.3.2 Protect the modules from high temperature and humidity. [避免處於高溫高濕下]

16.3.3 Keep the modules out of direct sunlight or direct exposure to ultraviolet rays.

[遠離陽光曝曬或直接曝露在紫外線下]

16.4 Use the module with a power supply that is equipped with an over current protector circuit, since the module is not provided with this protective feature.

[因為模組本身沒有防護，所以模組的供應器應配有過高電流的保護迴路]

16.5 Do not ingest the LCD fluid itself should it leak out of a damaged LCD module. Should hands or clothing come in contact with LCD fluid, wash immediately with soap.

[LCD 破裂液晶外漏時，切勿食下液晶；若手或衣服接觸到液晶，請立刻用肥皂清洗]

16.6 Conductivity is not guaranteed for models that use metal holders where solder connections between the metal holder and the PCB are not used. Please contact us to discuss appropriate ways to assure conductivity.

[當金屬框並沒焊接於 PCB 板上時，無法保證使用金屬框是具有傳導性，請連絡我們商討適當方式傳導]

### 16.7 For models which use CCFL [CCFL 的模組]:

16.7.1 High voltage of 1000V or greater is applied to the CCFL cable connector area.

[CCFL 排線連接器用於 1000V 以上的高電壓]

16.7.2 Protect CCFL cables from rubbing against the unit and thus causing the wire jacket to become worn. [CCFL 排線必須有保護 CCFL 與模組磨擦，以防 CCFL 外殼受到損害]

16.7.3 The use of CCFLs for extended periods of time at low temperatures will significantly shorten their service life. [長時間低溫使用 CCFL 會明顯縮減其使用壽命]

16.8 For models which use touch panels [觸控式面板模組]:

16.8.1 Do not stack up modules since they can be damaged by components on neighboring modules.  
[勿堆疊模組以防損壞]

16.8.2 Do not place heavy objects on top of the product. This could cause glass breakage.  
[勿將重物放置在產品上，會導致玻璃破損]

16.9 For models which use COG & TAB [COG 及 TAB 模組]:

16.9.1 The mechanical strength of the product is low since the IC chip is faces out unprotected from the rear. Be sure to protect the rear of the IC chip from external forces.  
[由於 IC 晶片表面無防護，所以抗壓力有限，須加強保護以防外力]

16.9.2 Given the fact that the rear of the IC chip is left exposed, in order to protect the unit from electrical damage, avoid installation configurations in which the rear of the IC chip runs the risk of making any electrical contact.  
[勿暴露 IC 晶片以防電氣干擾，且避免安裝 IC 時有任何電子接觸]

16.10 Models which use flexible cable, heat seal, or TAB [加有軟排線、熱封條或 TAB 的模組]:

16.10.1 In order to maintain reliability, do not touch or hold by the connector area.  
[以維持產品信賴度，請勿觸碰或握住連接器]

16.10.2 Avoid any bending, pulling, or other excessive force, which can result in broken connections. [避免彎曲、拉扯或過度力量，會造成連接器損壞]

16.11 In case of acrylic plate is attached to front side of LCD panel, cloudiness (very small cracks) can occur on acrylic plate, being influenced by some components generated from polarizer film.

Please check and evaluate those acrylic materials carefully before use.

[貼在 LCD 玻璃前面的壓克力板若有模糊情況(微小裂縫)，即會影響偏光板；使用前請仔細確認壓克力材質]

16.12 In case of buffer material such as cushion/gasket is assembled into LCD module, it may have an adverse effect on connecting parts (LCD panel-TCP/ HEAT SEAL/ FPC, PCB-TCP/HEAT SEAL/FPC, TCP-HEAT SEAL, TCP-FPC, HEAT SEAL-FPC) depending on its materials.

Please check and evaluate these materials carefully before use.

[緩衝原料像是減震墊/襯墊，或許會對連接器(LCD panel-TCP/ HEAT SEAL/ FPC, PCB-TCP/HEAT SEAL/FPC, TCP-HEAT SEAL, TCP-FPC, HEAT SEAL-FPC)造成反效果，使用前請仔細確認材料]

## 17. Warranty [保證]:

This product has been manufactured to your company's specifications as a part for use in your company's general electronic products. It is guaranteed to perform according to delivery specifications. For any other use apart from general electronic equipment, we cannot take responsibility if the product is used in medical devices, nuclear power control equipment, aerospace equipment, fire and security systems, or any other applications in which there is a direct risk to human life and where extremely high levels of reliability are required. If the product is to be used in any of the above applications, we will need to enter into a separate product liability agreement.

[此產品的製造是依照客戶的規格，被使用於客戶的一般電子產品上，保證產品製作根據出貨的規格，若產品的使用不是在一般電子設備，而組裝於下列產品上則無法受理（如醫療產品、核心電源控制設備、航空設備、防火及保全系統，或任何相關儀器會直接影響人類生命等），若模組使用於上述的儀器，則需商討各別產品責任義務的協定]

- 17.1 We cannot accept responsibility for any defect, which may arise after the application of strong external force to the product.  
[不受理因強大外力衝擊造成產品的缺陷]
- 17.2 We cannot accept responsibility for any defect, which may arise from additional manufacturing of the product (including disassembly and reassembly), after product delivery.  
[不受理產品出貨後，因額外加工(包含拆裝及重新封包)造成的缺陷]
- 17.3 We cannot accept responsibility for any defect, which may arise due to the application of static electricity after the product, has passed your company's acceptance inspection procedures.  
[不受理通過貴公司檢驗流程後，由於靜電造成產品的缺陷]
- 17.4 We cannot accept responsibility for intellectual property of a third party, which may arise through the application of our product to your assembly with exception to those issues relating directly to the structure or method of manufacturing of our product.  
[不受理因在客戶產品生產線端所產生的第三人智慧財產權責任，除非與我司生產製造方法有直接關係的問題]
- 17.5 When the product is in CCFL models, CCFL service life and brightness will vary according to the performance of the inverter used, leaks, etc. We cannot accept responsibility for product performance, reliability, or defect, which may arise.  
[產品是 CCFL 模組時，CCFL 的壽命及亮度將取決於連接器的性能、漏電量等；無法受理因 CCFL 造成產品性能的缺陷]
- 17.6 SDEC will not be held responsible for any quality guarantee issue for defect products longer than 1(one) year from SDEC production which ever comes later.  
[出廠超過一年的瑕疵品，任何品質擔保則不受理]

18. Processing Diagram [加工圖] :

● **SGS19264A0JEW02 焊接加工圖**

客戶名稱：McTronic

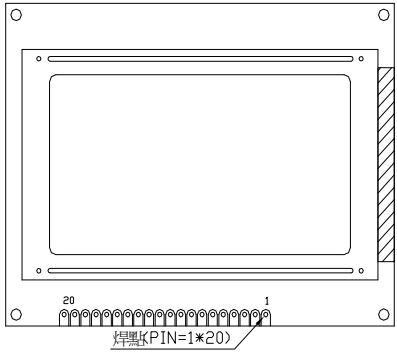

焊點K(PIN=1\*20)

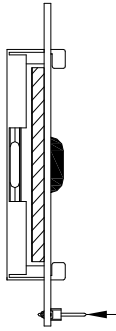

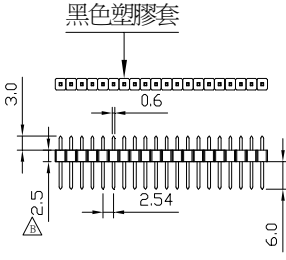

黑色塑膠套

焊接時不可有傾斜的現象，要與PCB呈90°直角。(請使用焊接治具)

◎ 排針提供品 (1\*20 180°排針)  
(上3.0mm下6.0mm膠高2.5mm)

◎ 排針加工時，務必注意排針有長、短端的方向。(長端含黑色套朝模組PCB零件面，短端朝LCD面)

◎ 焊接加工時，絕對不可有錫珠/錫渣/吃錫不良/吃錫過多/螺絲孔或未加工之零件位置沾錫(含排針)/包焊/假焊/空焊/焊接後排針長短不一/黑色套燙傷等現象。

SDEC SDEC TECHNOLOGY CORP		規格	項次	變更內容	日期
品名	圖號	Vop	1	標註膠高2.5mm	
製圖	日期	DUTY	2		
確認	日期	BIAS	3		
審核	日期	公差±0.2單位mm	4	o'clock	
		比例	版本	B版	

PAGE : 1 / 1

OPERATIVE TEMP	
STORAGE TEMP	