

Rev1	06,13,'06	First release (SPD 4W0265)
Rev2	07,21'06	Change Length of tape

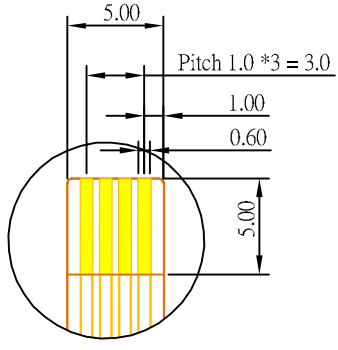
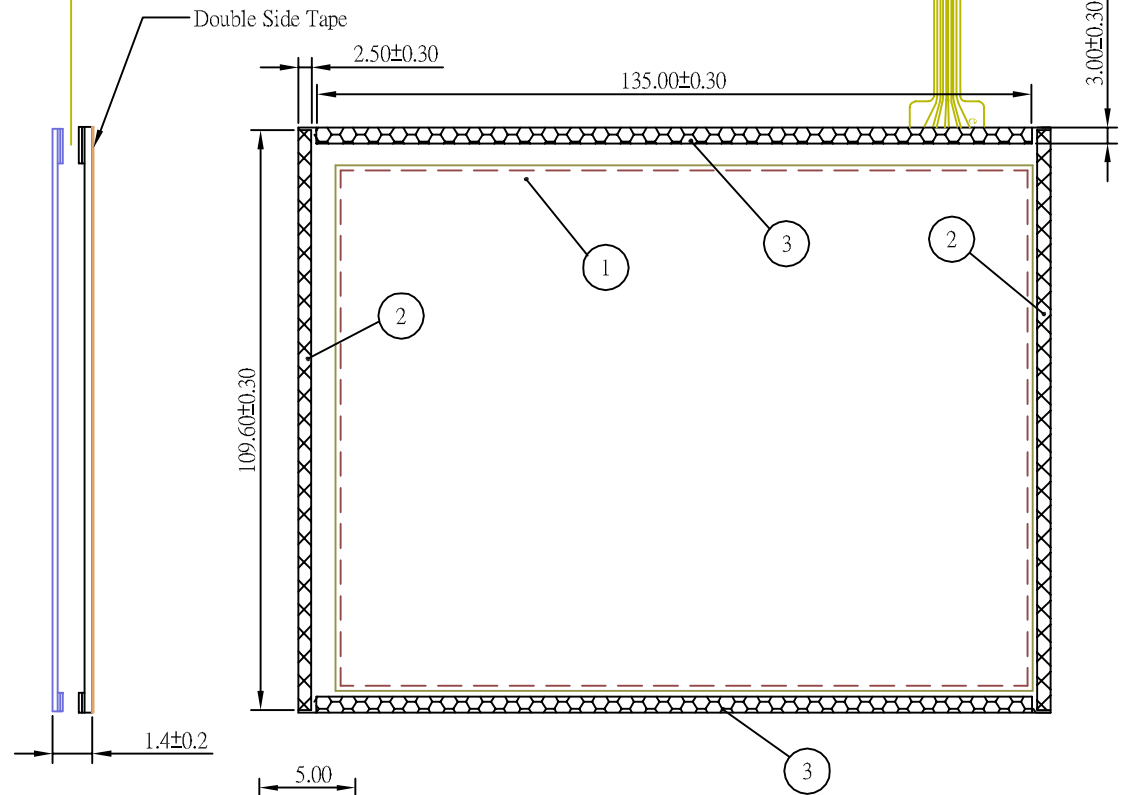
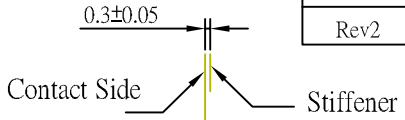
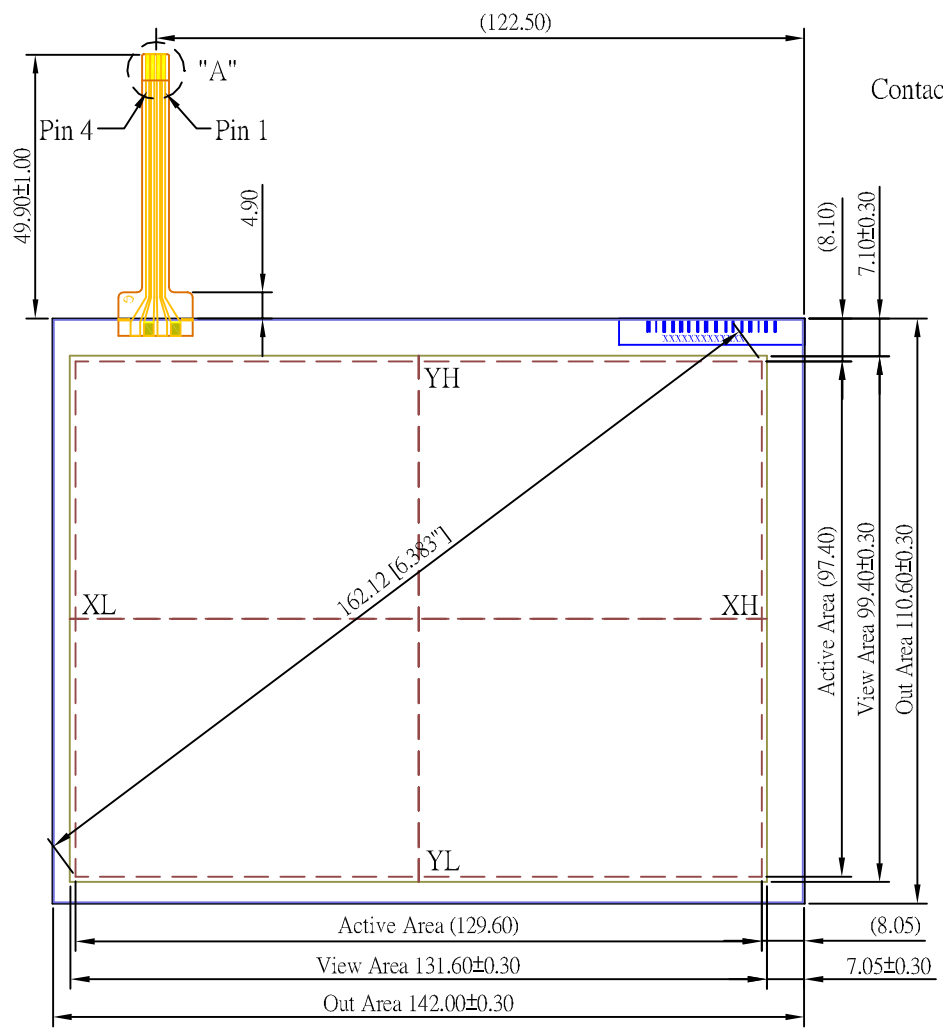

PIN OUT	
1	YL
2	XH
3	YH
4	XL

No.	Item	Part Number	Qty
3.	Double side tape	TMD2120060	2
2.	Double side tape	TMD2120070	2
1.	Touch screen	S4-063C11P4Z3PD1	1

- NOTES:
- TOPSHEET FINISH IS POLISH TYPE
 - GLASS THICKNESS IS 1.1mm
 - FLEXTAIL DO NOT BEND TO LESS THAN 3.175mm RADIUS
 - TAIL ACCEPTS 1mm PITCH ZIF CONN
 - OVERALL SENSOR THICKNESS IS 1.4±0.2mm

- SENSOR INPUT PEN / FINGER
- Double Side Tape TMD2120060 and TMD2120070 is Thk. 0.05mm (#4972)

THIRD ANGLE PROJECTION		Dimensions m/m
Drawn by Orly Lin	Scale FREE	
Checked by	Release Date 07,13,'06	

Drawing Number S4-063C11P4Z3PD1