



# YETDA INDUSTRY LTD.

## 2.3" SINGLE DIGIT WHITE ALPHANUMERIC DISPLAY

### S-23011RW11

#### DESCRIPTION

- \* 2.3" (56.8mm) Inch Digit Height.
- \* High Bright WHITE Display.
- \* Black Face and White Segment Color.
- \* Common Cathode.

#### ABSOLUT MAXIMUM RATINGS AT Ta=25°C

Parameter		UNIT
Power Dissipation Per Seg.	80	mW
Power Dissipation Per Dot	40	
Peak Forward Current Per Seg. & Dot	60	mA
Forward current Per Seg. & Dot (Static)	20	mA
Reverse Voltage Per Seg.	10	V
Reverse Voltage Per Dot	5	
Operation Temperature Range	-25°C TO +80°C	°C
Storage Temperature Range	-25°C TO +100°C	°C
Lead Soldering Temperature	260°C for 3 seconds 1.6mm(1/16 inch) from body	

#### ELECTRICAL/OPTOTICAL CHARACTERISTIC AT Ta=25°C

PARAMETER	SYMBOL	MIN.	TYP.	MAX.	UNIT	CONDITION
Average Luminous Intensity	Iv	200			mcd	If=20mA
Chromaticity Coordinate	X		0.29		nm	If=20mA
Chromaticity Coordinate	Y		0.30			
Forward Voltage Per Seg.	Vf		6.0	6.7	V	If=20mA
Forward Voltage Per Dot			3.0	3.4		
Reverse Current Per Seg.	Ir			10	uA	Vr=5V
Luminous Intensity Matching Ratio	Iv-m		2 : 1			If=20mA



YETDA INDUSTRY LTD.

### P.C.B. Pin Connection

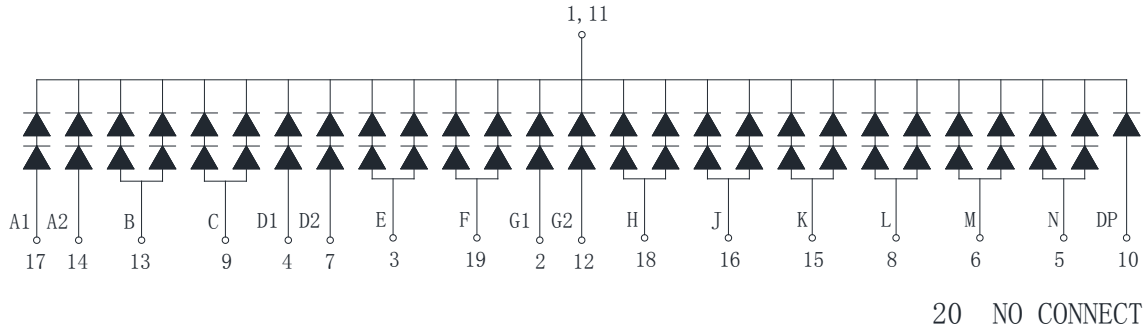

### Reflector Dimensions

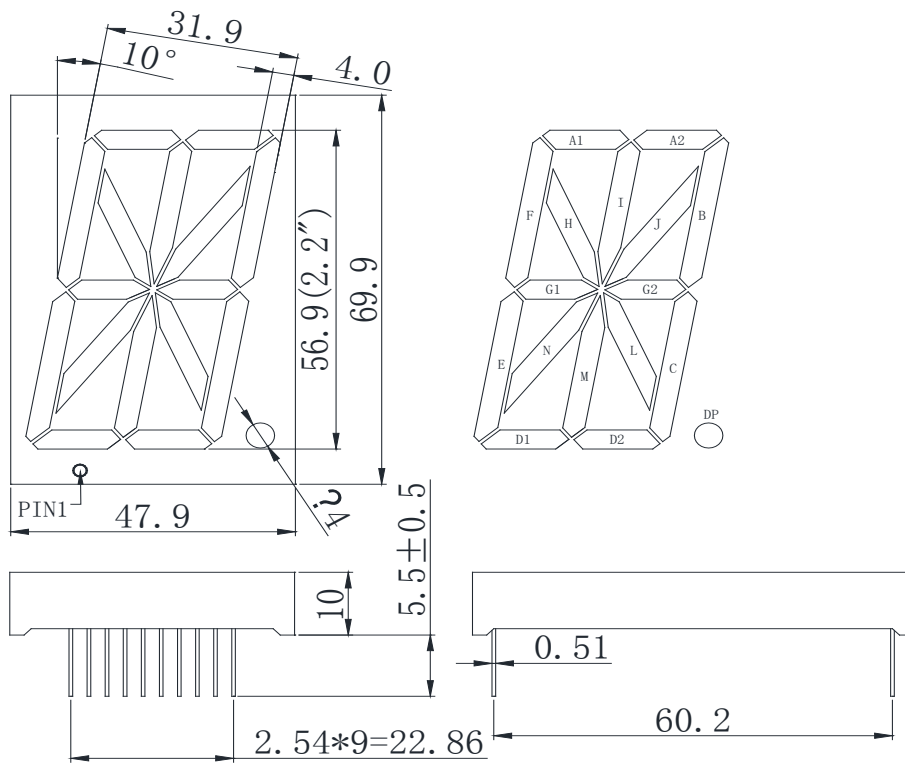

Unit:mm



# YETDA INDUSTRY LTD.

## •Soldering:

### 1. Manual of soldering

The temperature of the iron tip should not be higher than 260 °C and

Soldering within 3 seconds per solder-land is to be observed

### 2. DIP soldering (Wave Soldering):

Preheating: 120

°C ~ 150°C within 5 sec. 260°C (Max)

Gradual Cooling (Avoid quenching)

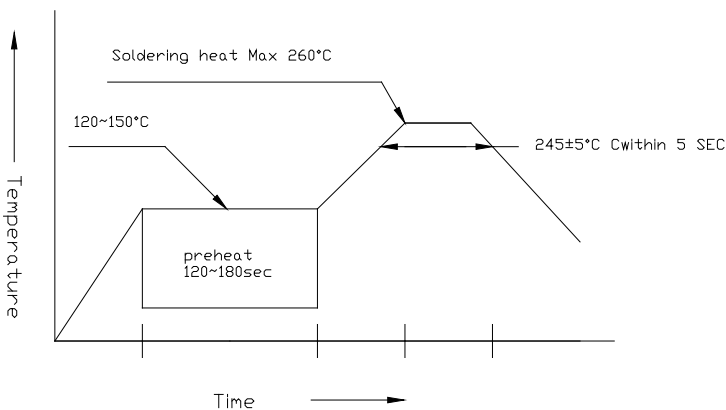

### 3. Reflow Soldering

Preheating: 140

°C ~ 160°C ±5°C, within 2 minutes.

Operation heating: 235

°C (Max) within 10 seconds (Max)

Gradual Cooling (Avoid quenching)

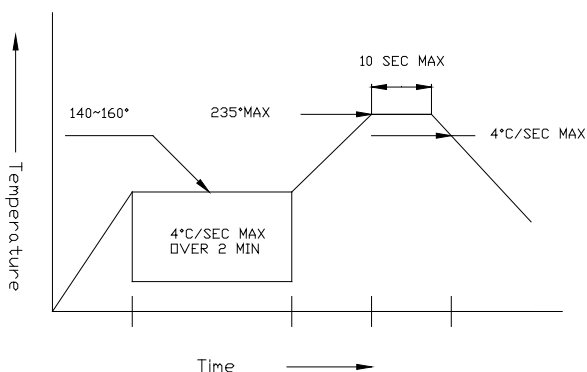

## •Handling:

Care must be taken not to cause to the epoxy resin portion of Yetda LEDs while it is exposed to high temperature.

Care must be taken not rub the epoxy resin portion of Yetda LEDs with hard or sharp article such as the sand blast and the metal hook