



TR5000/TR6000 Serial

Resistive Sensor

General Specification



No part of this document may be reproduced or transmitted in any form or by any means, electronic or mechanical, for any purpose, without the express written permission of eTurboTouch Technology, Inc. eTurboTouch may have patents or pending patent applications, trademarks, copyrights, or other intellectual property rights covering subject matter in this document. The furnishing of this document does not give you license to these patents, trademarks, copyrights, or other intellectual property except as expressly provided in any written license agreement from eTurboTouch.

For the latest detailed engineering specifications, please contact your eTurboTouch application engineer. eTurboTouch Technology is committed to continually improving product designs, as a result, product specifications may be subject to change without notification.

Copyright

© 2002-07 eTurboTouch Technology, Inc. All rights reserved.

Trademark

eTurboTouch, the eTurboTouch logo, are registered trademarks of eTurboTouch Technology Incorporated.

2011/03/14

Part No: M6-000024

Version: 1.2

2010/05/27 To revise eTurboTouch logo.

Contents

1. Revision History	4
2. Scope (Range of Application)	5
3. Shape and Dimensions	5
4. Mechanical Characteristics	5
5. Reliability Characteristics	5
6. Durability Characteristics	6
7. Sensor Cosmetics.....	7
8. Label Illustration	10
9. Cautions	11
10. Touch Panel Drawing.....	11
11. Copyright, Warranty and Service Support	12

Revision History

P/N: _____

Version	Revision Description	Date
1.0	General release	2007.08.30
1.1	Revise eTurboTouch Logo	2010/05/27
1.2	Consumer Application	2011/03/14

1. *Scope (Range of Application)*

This specification defines special provisions as well as inspection standards for touch panel supplied by eTurboTouch.

2. *Shape and Dimensions*

This document applies to a wide range of shapes of eTurboTouch 5W/6W resistive touch sensors. You have to contact to eTurboTouch sales engineers for a specific sensor dimensioned drawing for your necessity. (Shape: Rectangle, flat, Dimensions: 5.7” to 19.1” diagonal, glass thickness: 1.1 to 2.8 mm) For approval please reference **Touch Panel Drawing**.

3. *Electrical Characteristics*

3-1 Insulation Resistance: 20M ohm or more @DC 25V

3-2 Chattering Time: 10 msec or less

3-3 Linearity: $\pm 1.5\%$ error or less for X and Y axis.

Note : the maximum error is 1.5 % of the diagonal of the active area. (Positional accuracy shall be reported in terms of the standard deviation for both the X and Y axis using eTT test Software as the data collection and calculations tool.)

4. *Mechanical Characteristics*

4-1 Input Method: Touch stylus or finger (Palm rejection model only recommend stylus input)

4-2 Touch Activation Force:

4-2-1 Pen touch force: $\leq 120\text{g}$ (Tip polyacetal POM diameter 0.8mm)

4-2-2 Finger touch force: $\leq 120\text{g}$ (Silicon Rubber SR 50HS diameter 8mm)

Note: Palm rejection model touch panel force: $> 1.2\text{kg}$;(Silicon Rubber SR 45HS R8mm)

4-3 Surface Pencil Hardness: pencil hardness $\geq 3\text{H}$ per ASTM D 3363.

4-4 Light Transmittance:

Light Transmission testing is in accordance with ASTM D 1003. Film on glass product $>78\%$ at 550 nm wavelength (visible light spectrum).

5. *Reliability Characteristics*

5-1 Operating environment:

5-1-1 -10°C to 35°C , humidity 10%~90%

5-1-2 $>35^{\circ}\text{C}$ to 50°C , humidity 10%~60%

Functional operating limits: 90% RH at max 35°C for 24 Hrs, non-condensing.

Note: Functionality is not adversely affected within these operating guidelines.

5-2 Storage environment:

5-2-1 -30°C to 35°C, humidity 10%~90%

5-2-2 >35°C to 70°C, humidity 10%~60%

Functional operating limits: 90% RH at max 35°C for 24 Hrs, non-condensing.

Note: Functionality is not adversely affected within these operating guidelines

5-3 Thermal Cycling

The touch panel shall be capable of functioning normally after the completion of fifteen thermal cycles from room conditions to 70° C/ 60min, and then to -40° C/ 60min and back to room temperature; and then to -40° C and back to room temperature at a rate not to exceed 2° C per minute and with a one hour soak at each temperature extreme.

Note : After the reliability test, the film may have the condition of bubble; nevertheless the electrical characteristics still satisfies the following standard $X \leq 2.5\%$, $Y \leq 2.5\%$ touch error.

5-4 Chemical Resistance

The active area of the touchscreen is resistant to the following chemicals when exposed for a period of one hour at a temperature of 70°F (21°C): Industrial Chemicals: Acetone, Methylene chloride, Methyl ethyl ketone, Isopropyl alcohol, Hexane, Turpentine, Mineral spirits, Unleaded Gasoline, Diesel Fuel, Motor Oil, Transmission Fluid, Antifreeze.

6. Durability Characteristics

6-1 Pen Sliding :

Operationally test more than 100K times (Tip polyacetal POM diameter 0.8mm /Loading 250g) in same location without failure.

6-2 Pen Hitting:

Operationally test more than 1M times.(Tip polyacetal POM diameter 0.8mm/Loading 250g) in same location without failure.

6-2 Finger Touch:

Operationally test more than 1M times.(Silicon Rubber SR50HS diameter 8mm/Loading 250g) in same location without failure.

7. Sensor cosmetics

7-1 Inspection Condition

Light source: 700 -1400 LUX fluorescent lamps.

Method: Position the sensor 30(\pm 5)cm far from human eyes with an angle between 15-45 degrees.

Viewing Time: 15(\pm 3) seconds

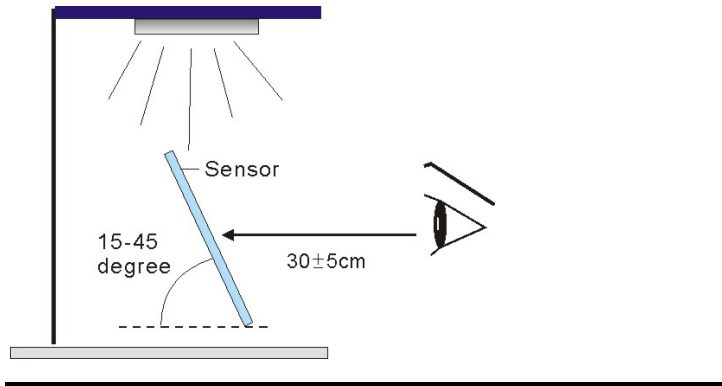

7-2 Inspection condition: use either one of the following three patterns to aid your eye.

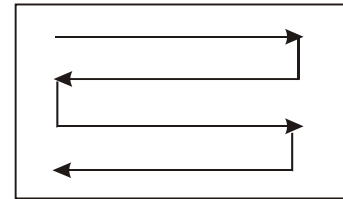
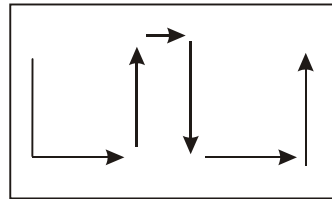
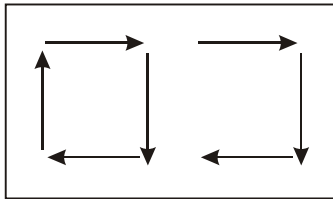

7-3 Criterion

Except for any other written agreement, the incoming inspection shall be based on MIL-STD-105E. Acceptable quality level (AQL) = 0.65, single sampling, normal inspection, level II.

The followings are applied to viewing area. Any defects in invisible shall be ignored unless they affect electrical performance. This section is just to check the VA (view-area), if the defect was found in none VA. It is acceptable.

The table below shows the visual inspection for sensors under 12”:

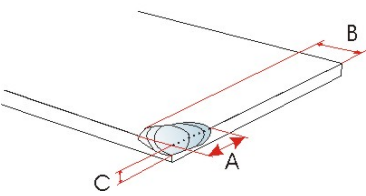
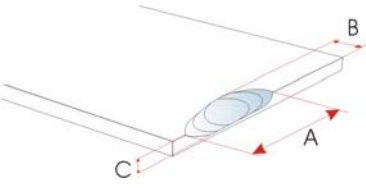
<i>Items/Type</i>	<i>Specifications Explain</i>	
Scratch	Width / Length	Judgment
	$W \leq 0.05\text{mm}$ and $L \leq 3\text{mm}$	Ignore
	$0.05\text{mm} < W \leq 0.1\text{mm}$ and $3\text{mm} < L \leq 15\text{mm}$	Allow 2 and min distance above 20mm is Qualified (PASS)
	$W > 0.1\text{mm}$ or $L > 15\text{mm}$	Unqualified (NG)
Foreign Objective	(Width+Length)/2	Judgment
	*0.2 mm	Qualified (PASS)
	Polish film 0.2mm ~ 0.3mm Anti-glare film 0.2mm~0.4mm	Qualified (PASS) & allow 4 points interval distance above 20mm
	Polish film > 0.3 mm Anti-glare film > 0.4 mm	Unqualified (NG)
Linear Foreign Objective	Width / Length	Judgment
	$\leq 0.1\text{mm}$ (W) and $\leq 5\text{mm}$ (L)	Allow 2 and min distance above 20mm is Qualified (PASS)
	$> 0.1\text{mm}$ (W) or $> 5\text{mm}$ (L)	Unqualified (NG)
Puffiness	Height under 0.4 mm	Qualified (PASS)
Film Surface Flat	Film from reflect light the shape like C	Qualified (PASS)
	Film from reflect light the shape like S	Unqualified (NG)
Glass Fragment	Corner Fragment 	a* 2.0mm, b* 2.0mm and c * t mm, (t: Glass Thickness) No more than 2 is qualified (PASS)
	Side Fragment 	a * 3mm , b * 2.0mm and c * 1/2 t mm, (t: Glass Thickness) Allow 3 fragments interval distance above 20mm every side is qualified (PASS)

The table below shows the visual inspection for sensors above 12”:

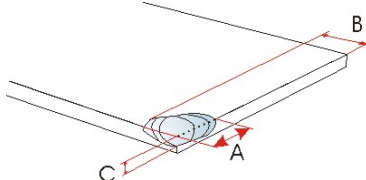
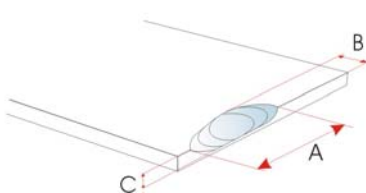
Items/Type	Specifications Explain	
Scratch	Width / Length	Judgment
	$W \leq 0.05\text{mm}$ and $L \leq 7\text{mm}$	Ignore
	$0.05\text{mm} < W \leq 0.1\text{mm}$ and $7\text{mm} < L \leq 30\text{mm}$	Allow 2 and min distance above 20mm is Qualified (PASS)
	$W > 0.1\text{mm}$ or $L > 30\text{mm}$	Unqualified (NG)
Foreign Objective	(Width+Length)/2	Judgment
	*0.2 mm	Qualified (PASS)
	Polish film 0.2mm ~ 0.3mm Anti-glare film 0.2mm~0.4mm	Qualified (PASS) & allow 4 points interval distance above 20mm
	Polish film > 0.3 mm Anti-glare film > 0.4 mm	Unqualified (NG)
Linear Foreign Objective	Width / Length	Judgment
	$\leq 0.1\text{mm}$ (W) and $\leq 5\text{mm}$ (L)	Allow 2 and min distance above 20mm is Qualified (PASS)
	$> 0.1\text{mm}$ (W) or $> 5\text{mm}$ (L)	Unqualified (NG)
Puffiness	Height under 0.4 mm	Qualified (PASS)
Film Surface Flat	Film from reflect light the shape like C	Qualified (PASS)
	Film from reflect light the shape like S	Unqualified (NG)
Glass Fragment	Corner Fragment 	a* 2.0mm, b* 2.0mm and c * t mm, (t: Glass Thickness) No more than 2 is qualified (PASS)
	Side Fragment 	a * 3mm , b * 2.0mm and c * 1/2 t mm, (t: Glass Thickness) Allow 3 fragments interval distance above 20mm every side is qualified (PASS)
Newton Ring	Check tooling: Newton ring tooling. Above 12” : Newton ring diameter cannot be over 30mm. 1 Newton ring found in sensor is qualified (PASS).	

8. Label Illustration

8-1 Definition for the Bar Code

Each number and letter represents different meaning.



(*Barcode Type : Code128)

“**SX**” means Sensor Type

“**aaa**” means diagonal of active area

“**b**” means Pattern

“**cc**” means Thickness

“**ddd**” means Tail and connector Type

“**ee**” means Glass / Surface

“**ff**” means product category and serial number

“**i**” means version number

“**j**” means year

“**k**” means month

“**ll**” means the production item of that month

“**mmmm**” means the serial number

8-2 Definition for the Outside Carton Bar Code

Each number and letter represents different meaning.



(*Barcode Type : Code128)

“**SX**” means Sensor Type

“**aaa**” means diagonal of active area

“**b**” means Pattern

“**cc**” means Thickness

“**ddd**” means Tail and connector Type

“**ee**” means Glass / Surface

“**ff**” means product category and serial number

“**y**” means year:

“**ww**” means the week of the year production

“**nnn**” the serial number of the carton

9. Cautions

In order to prevent accidental use and be guaranteed the performance of product, you are requested to keep the following:

9-1 Usage

- Use eTT qualified stylus only.

9-2 Storage

- Store the products at recommended temperature and humidity range.
- Store the products in the state of package.
- Do not expose the touch panel to the sun directly.

9-3 Unpacking

- Do not hold FPC/Copper tail to take touch panels out in the package.
- Open the package after checking the "UP/DOWN" mark.
- Do not put the heavy shock and stress on touch panel.

9-4 Handling

- Put on gloves to prevent stains on the touch panel and prevent injured by the sharp edge of the touch panel.
- Do not hold FPC/Copper tail while handling the touch panel.
- Do not pile up touch panel and put heavy matter on touch panel.
- Do not add any stress on touch film.
- Use dry cloth or soft cloth with alcohol, neutral detergent or ethanol for clearing the touch panel in case of dirt on it.
- Do not use any organic solvents except alcohol.
- Recommend operator put on gloves to do assembly.

9-5 Assembling

- Avoid excessive force on the touch panel.
- Do not give unnecessary strain to the FPC/Copper tail on assembling.
- Special design is required for water resistance use.
- Material of supporting to bond touch panel is elastic adhesive.
- Enclosure edge must be located between view-area and guaranteed active area.
- Enclosure supporting to bond touch panel must be out of the view area.

10. Touch Panel Drawing

11. Copyright, Warranty and Service Support

This document contains proprietary information protected by copyright. All rights are reserved. No part of this document can be photocopied, reproduced or translated without the prior written consent of eTurboTouch Technology Inc.

12 months limited warranty after shipment under storage, shipment conditions as described in this specification.

The general specification is for reference only. Kindly be noted that will have no notice for any further changes or modification of the general specification due to the testing conditions changed. The latest general specification will be sent to you upon requests.



eTurboTouch Technology Inc.

No.2, Nanyuan Rd., Jhongli City Taoyuan County 320, Taiwan, R.O.C.

Tel:886-3-4623889 Fax:886-3-4611237

Web-Site: www.eturbotouch.com.tw