



# THINGWELL ELECTRONICS

TEL:+86-755-27435731 FAX:+86-755-27132381

<http://www.lcdmaker.com>

---

## SPECIFICATION FOR LCM MODULE

MODULE NO.: LCM16032B-Y

REVISION NO.: A

---

Customer Approval:

--

	SIGNATURE
PREPARED BY	
VERIFIED BY	
APPROVED BY	



# THINGWELL ELECTRONICS

TEL:+86-755-27435731 FAX:+86-755-27132381

<http://www.lcdmaker.com>

---

## RECORDS OF REVISION

Date	Rev.	Description	Page	Design by
2011/8/22	0	New Sample.	-	-
			-	-



# THINGWELL ELECTRONICS

TEL:+86-755-27435731 FAX:+86-755-27132381

<http://www.lcdmaker.com>

---

## Contents

### **1. SPECIFICATIONS**

- 1.1 Features**
- 1.2 Mechanical Specifications**
- 1.3 Absolute Maximum Ratings**
- 1.4 Backlight & LED Characteristics**

### **2. MODULE STRUCTURE**

- 2.1 Counter Drawing**
- 2.2 Interface Pin Description**
- 2.3 Timing Characteristics**
- 2.4 Instruction Table**
- 2.5 Inspection Specification**



# THINGWELL ELECTRONICS

TEL:+86-755-27435731 FAX:+86-755-27132381

<http://www.lcdmaker.com>

## 1. SPECIFICATIONS

### 1.1 Features

Item	Standard Value
Display Type	160X32 DOTS
LCD Type	STN(Y-G), POSITIVE, TRANSFLECTIVE
Driver Condition	LCD Module : 1/32Duty , 1/5Bias
Viewing Direction	6 O'clock
Backlight Type	SIDE Y-G
Interface	8BIT bus MPU interface
Driver IC	AIP31020

### 1.2 Mechanical Specifications

Item	Standard Value	Unit
Outline Dimension	122(L) *44(W) * Max 13.3 (T)	mm
Viewing Area	99(L) * 24( W)	mm
Dot Size (W*H)	0.51*0.52mm	
Dot Pitch (W*H)	0.56*0.57 mm	

### 1.3 Absolute Maximum Ratings

Item	Symbol	Condition	Min.	Max.	Unit
System Power Supply Voltage	VDD	-	-0.3	5.5	V
LCD Driver Supply Voltage	VOUT <sub>IN</sub>	-	4.8	5.0	V
Input Voltage	V <sub>IN</sub>	-	-0.3	VDD + 0.2	V
Operating Temperature	T <sub>OP</sub>	-	-20	70	°C



# THINGWELL ELECTRONICS

TEL:+86-755-27435731 FAX:+86-755-27132381

<http://www.lcdmaker.com>

Storage Temperature	T <sub>ST</sub>	-	-30	80	°C
Storage Humidity	H <sub>D</sub>	Ta < 40 °C	20	80	%RH

## 1.4 Backlight Characteristics

LCD Module without LED Backlight

Electrical / Optical Characteristics

Ta =25°C

Item	Symbol	Conditions	Min.	Typ.	Max.	Unit
Forward Voltage	V <sub>f</sub>	I <sub>f</sub> =30mA	3.0	3.1	3.2	V
Reverse Current	I <sub>r</sub>	I <sub>f</sub> =5v			--	uA
Average Brightness	I <sub>V</sub>	I <sub>f</sub> =30mA				cd/m <sup>2</sup>
Wavelength (Without LCD)	λ <sub>d</sub>	I <sub>f</sub> =30mA	--	--	--	nm
Luminous Intensity (without LCD)	L <sub>v</sub> Sub	I <sub>f</sub> =30mA				cd/m <sup>2</sup>
Uniformity	Δ%	I <sub>v</sub> Min / I <sub>v</sub> Max *100%	--	-	-	%
Color	Y-G					



# THINGWELL ELECTRONICS

TEL:+86-755-27435731 FAX:+86-755-27132381

<http://www.lcdmaker.com>

---

## **2. MODULE STRUCTURE**

### **2.1 Counter Drawing**

#### **2.1.1 LCM Mechanical Diagram**

INTERFACE	
1	VSS
2	VDD
3	V0
4	RS(CS)
5	RM(SID)
6	E(CLK)
7	DB0
8	DB1
9	DB2
10	DB3
11	DB4
12	DB5
13	DB6
14	DB7
15	PSB
16	N/C
17	/RST
18	VOUT
19	LEDA
20	LED-K

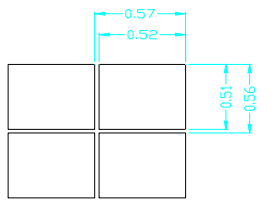
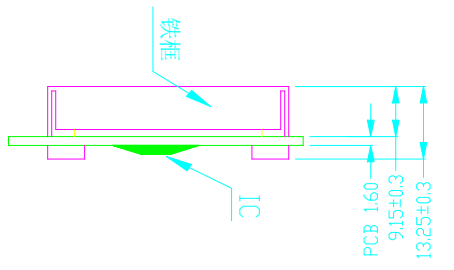
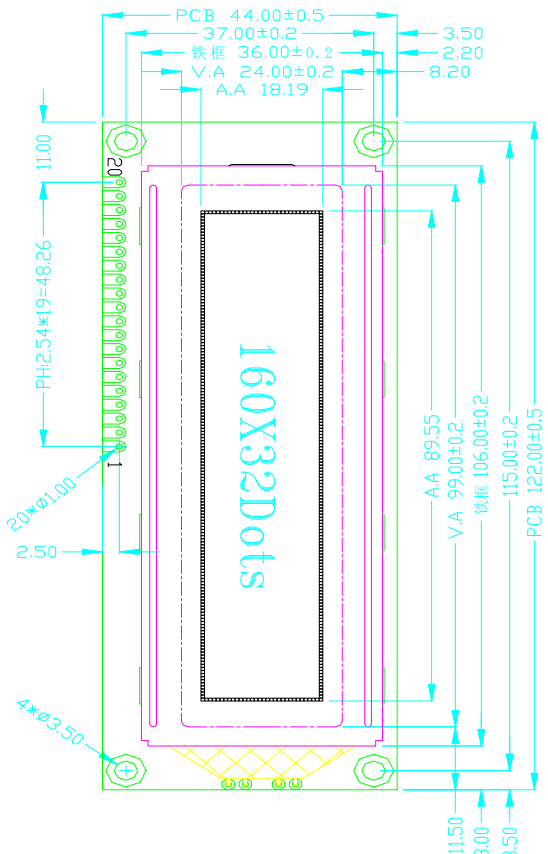

DOT SIZE:

- SPECIFICATION:**
- 1). STN (Y-G) / POSITIVE / TRANSFLECTIVE
  - 2). DUTY: 1/32. BIAS: 1/6. VOP=4. 5V
  - 3). VIEWING ANGLE: 6 0' CLOCK
  - 4). DRIVE VOLTAGE: 5. 0V
  - 5). OPERATING TEMPERATURE: -20~70°C  
STORAGE TEMPERATURE: -30~80°C
  - 6). BACKLIGHT: Y-G I=40mA
  - 7). DRIVE IC: AIP31020

VER	DETAIL DESCRIPTION	DATE
00	FIRST ISSUE	2013-3-29

**THINGWELL ELECTRONICS**

Unspecified	±0.20	UNITS: mm	DATE:	MODE NUMBER:		SHEET:	1 of 1
DESIGN BY:	wzq	2013/2/29		LCM16032B-Y		DATE:	2013/2/29
CHECKED BY:							
CUSTOMER:							

DO NOT SCALE THIS DRAWING.

## 2.2 Interface Pin Description

Pin No.	Symbol	Function
1	VSS	Ground (0V)
2	VDD	Power supply input for driver IC (+5V)
3	VO	LCD driver supply voltages, Contrast Adjust
4	RS	Register select input pin: RS = "H": DB0 to DB7 are display data RS = "L": DB0 to DB7 are control data
5	RW	Read write control 0:write 1:read
6	E	IC Enable trigger
7--14	DB0~DB7	data bus data
15	PSB	Interface selection:0:serial mode 1:8/4-bits parallel bus mode
16	N.C	No used
17	/RES	Reset signal
18	VOUT	No used
19	LED+	BACKLIGHT+ (5V)
20	LED-	BACKLIGHT- (0V)

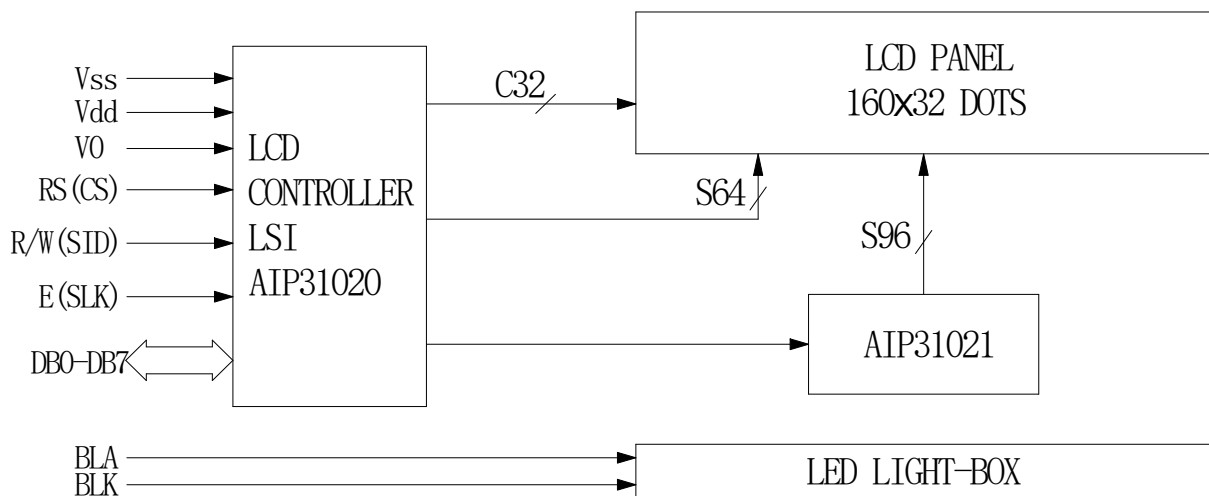

## 2.3 Timing Characteristics



**AC Characteristics ( $T_A = 25^{\circ}\text{C}$ ,  $V_{DD} = 4.5\text{V}$ ) Parallel Mode Interface**

Symbol	Characteristics	Test Condition	Min.	Typ.	Max.	Unit
<i>Internal Clock Operation</i>						
$f_{\text{OSC}}$	OSC Frequency	R = 33K $\Omega$	480	540	600	KHz
<i>External Clock Operation</i>						
$f_{\text{EX}}$	External Frequency	-	480	540	600	KHz
	Duty Cycle	-	45	50	55	%
$T_{\text{R}}, T_{\text{F}}$	Rise/Fall Time	-	-	-	0.2	$\mu\text{s}$
<i>Write Mode (Writing data from MPU to ST7920)</i>						
$T_{\text{C}}$	Enable Cycle Time	Pin E	1200	-	-	ns
$T_{\text{PW}}$	Enable Pulse Width	Pin E	140	-	-	ns
$T_{\text{R}}, T_{\text{F}}$	Enable Rise/Fall Time	Pin E	-	-	25	ns
$T_{\text{AS}}$	Address Setup Time	Pins: RS,RW,E	10	-	-	ns
$T_{\text{AH}}$	Address Hold Time	Pins: RS,RW,E	20	-	-	ns
$T_{\text{DSW}}$	Data Setup Time	Pins: DB0 - DB7	40	-	-	ns
$T_{\text{H}}$	Data Hold Time	Pins: DB0 - DB7	20	-	-	ns
<i>Read Mode (Reading Data from ST7920 to MPU)</i>						
$T_{\text{C}}$	Enable Cycle Time	Pin E	1200	-	-	ns
$T_{\text{PW}}$	Enable Pulse Width	Pin E	140	-	-	ns
$T_{\text{R}}, T_{\text{F}}$	Enable Rise/Fall Time	Pin E	-	-	25	ns
$T_{\text{AS}}$	Address Setup Time	Pins: RS,RW,E	10	-	-	ns
$T_{\text{AH}}$	Address Hold Time	Pins: RS,RW,E	20	-	-	ns
$T_{\text{DDR}}$	Data Delay Time	Pins: DB0 - DB7	-	-	100	ns
$T_{\text{H}}$	Data Hold Time	Pins: DB0 - DB7	20	-	-	ns
<i>Interface Mode with LCD Driver(ST7921)</i>						
$T_{\text{CWH}}$	Clock Pulse with High	Pins: CL1, CL2	800	-	-	ns
$T_{\text{CWL}}$	Clock Pulse with Low	Pins: CL1, CL2	800	-	-	ns
$T_{\text{CST}}$	Clock Setup Time	Pins: CL1, CL2	500	-	-	ns
$T_{\text{SU}}$	Data Setup Time	Pin: D	300	-	-	ns
$T_{\text{DH}}$	Data Hold Time	Pin: D	300	-	-	ns
$T_{\text{DM}}$	M Delay Time	Pin: M	-1000	-	1000	ns



# THINGWELL ELECTRONICS

TEL:+86-755-27435731 FAX:+86-755-27132381

<http://www.lcdmaker.com>

## DC Characteristics ( $T_A = 25^{\circ}C$ , $V_{DD} = 4.5 V - 5.5 V$ )

Symbol	Characteristics	Test Condition	Min.	Typ.	Max.	Unit
$V_{DD}$	Operating Voltage	-	4.5	-	5.5	V
$V_{LCD}$	LCD Voltage	$V_0 - V_{SS}$	3.0	-	7	V
$I_{CC}$	Power Supply Current	$f_{OSC} = 540KHz$ , $V_{DD} = 5V$ $R_f = 33K\Omega$	-	0.45	0.75	mA
$V_{IH1}$	Input High Voltage (Except OSC1)	-	$0.7V_{DD}$	-	$V_{DD}$	V
$V_{IL1}$	Input Low Voltage (Except OSC1)	-	-0.3	-	0.6	V
$V_{IH2}$	Input High Voltage (OSC1)	-	$V_{DD} - 1$	-	$V_{DD}$	V
$V_{IL2}$	Input Low Voltage (OSC1)	-	-	-	1.0	V
$V_{OH1}$	Output High Voltage (DB0 - DB7)	$I_{OH} = -0.1mA$	$0.8V_{DD}$	-	$V_{DD}$	V
$V_{OL1}$	Output Low Voltage (DB0 - DB7)	$I_{OL} = 0.1mA$	-	-	0.4	V
$V_{OH2}$	Output High Voltage (Except DB0 - DB7)	$I_{OH} = -0.04mA$	$0.8V_{DD}$	-	$V_{DD}$	V
$V_{OL2}$	Output Low Voltage (Except DB0 - DB7)	$I_{OL} = 0.04mA$	-	-	$0.1V_{DD}$	V
$I_{IEAK}$	Input Leakage Current	$V_{IN} = 0V$ to $V_{DD}$	-1	-	1	$\mu A$
$I_{PUP}$	Pull Up MOS Current	$V_{DD} = 5V$	75	80	85	$\mu A$

## 8 bit interface timing diagram

- MPU write data to ST7920

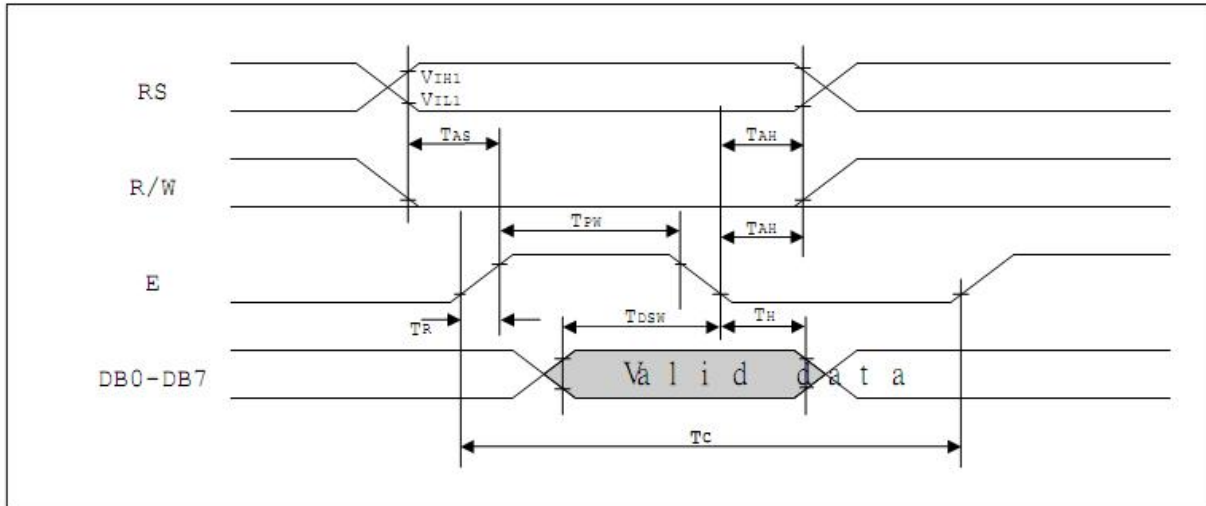

- MPU read data from ST7920

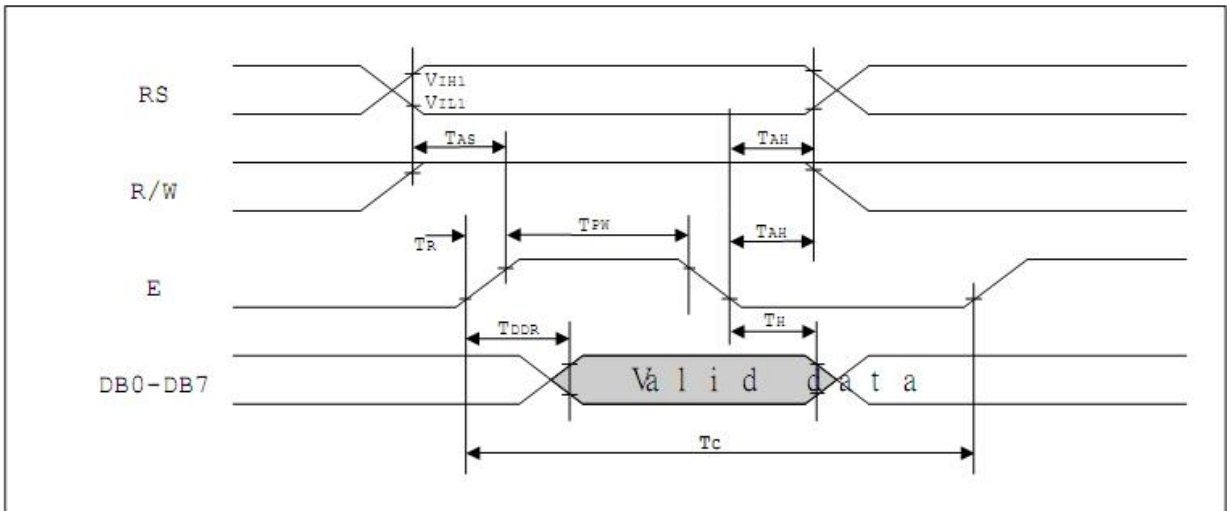

## Serial interface timing diagram

- MPU write data to ST7920

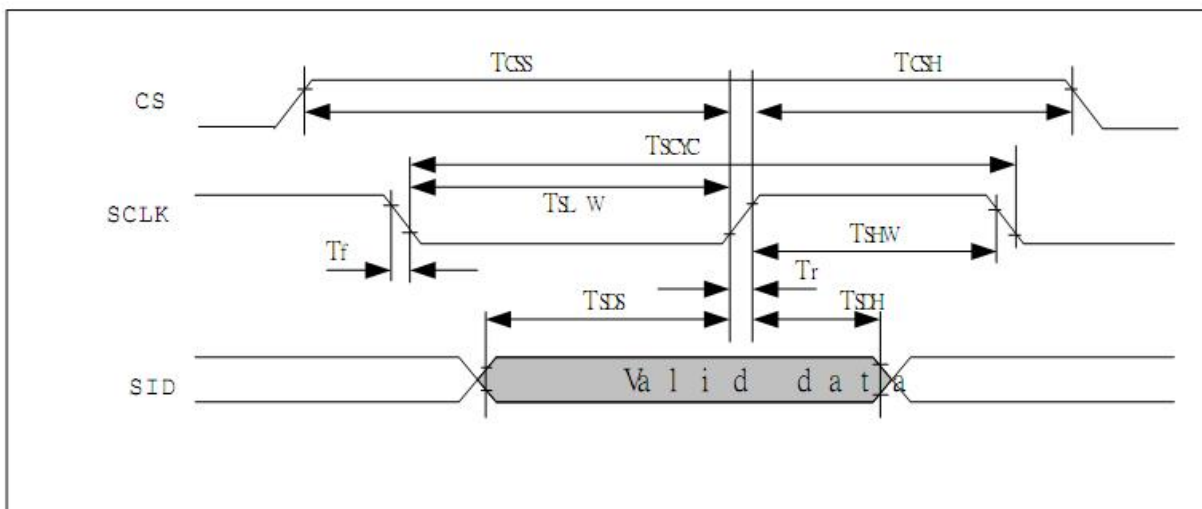

## External reset timing

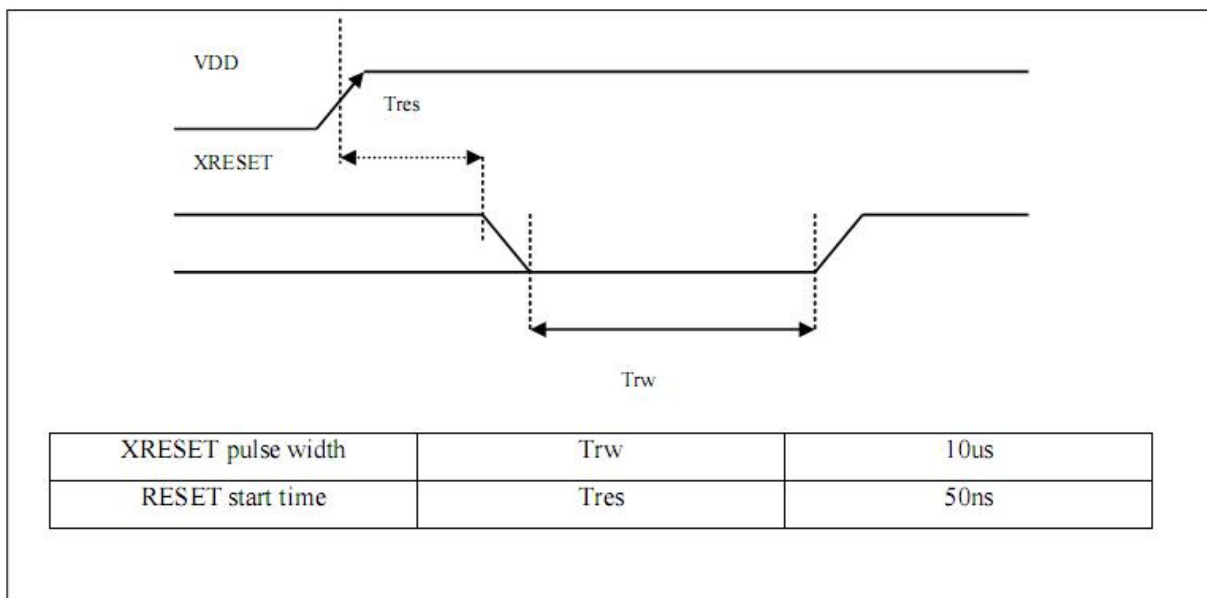



# THINGWELL ELECTRONICS

TEL:+86-755-27435731 FAX:+86-755-27132381

http://www.lcdmaker.com

## 2.4 Instruction Table

### Instruction set 1: (RE=0: basic instruction)

Ins	code											Description	Exec time (540KHZ)
	RS	RW	DB7	DB6	DB5	DB4	DB3	DB2	DB1	DB0			
CLEAR	0	0	0	0	0	0	0	0	0	0	1	Fill DDRAM with "20H", and set DDRAM address counter (AC) to "00H"	1.6 ms
HOME	0	0	0	0	0	0	0	0	0	1	X	Set DDRAM address counter (AC) to "00H", and put cursor to origin ; the content of DDRAM are not changed	72us
ENTRY MODE	0	0	0	0	0	0	0	0	1	I/D	S	Set cursor position and display shift when doing write or read operation	72us
DISPLAY ON/OFF	0	0	0	0	0	0	0	1	D	C	B	D=1: display ON C=1: cursor ON B=1: blink ON	72 us
CURSOR DISPLAY CONTROL	0	0	0	0	0	1	S/C	R/L	X	X	X	Cursor position and display shift control ; the content of DDRAM are not changed	72 us
FUNCTION SET	0	0	0	0	1	DL	X	0	RE	X	X	DL=1 8-BIT interface DL=0 4-BIT interface <b>RE=1: extended instruction</b> <b>RE=0: basic instruction</b>	72 us
SET CGRAM ADDR.	0	0	0	1	AC5	AC4	AC3	AC2	AC1	AC0		Set CGRAM address to address counter (AC) <b>Make sure that in extended instruction SR=0 (scroll or RAM address select)</b>	72 us
SET DDRAM ADDR.	0	0	1	0	AC5	AC4	AC3	AC2	AC1	AC0		Set DDRAM address to address counter (AC) AC6 is fixed to 0	72 us
READ BUSY FLAG (BF) & ADDR.	0	1	BF	AC6	AC5	AC4	AC3	AC2	AC1	AC0		Read busy flag (BF) for completion of internal operation, also Read out the value of address counter (AC)	0 us
WRITE RAM	1	0	D7	D6	D5	D4	D3	D2	D1	D0		Write data to internal RAM (DDRAM/CGRAM/IRAM/GDRAM)	72 us
READ RAM	1	1	D7	D6	D5	D4	D3	D2	D1	D0		Read data from internal RAM (DDRAM/CGRAM/IRAM/GDRAM)	72 us



# THINGWELL ELECTRONICS

TEL:+86-755-27435731 FAX:+86-755-27132381

http://www.lcdmaker.com

## Instruction set 2: (RE=1: extended instruction)

Inst.	code										description	Exec. time (540KHZ)	
	RS	RW	DB7	DB6	DB5	DB4	DB3	DB2	DB1	DB0			
STAND BY	0	0	0	0	0	0	0	0	0	1	1	Enter stand by mode, any other instruction can terminate (Com1..32 halted, only Com33 ICON can display)	72 us
SCROLL or RAM ADDR. SELECT	0	0	0	0	0	0	0	0	0	1	SR	SR=1: enable vertical scroll position SR=0: enable IRAM address ( <b>extended instruction</b> ) SR=0: enable CGRAM address( <b>basic instruction</b> )	72 us
REVERSE	0	0	0	0	0	0	0	0	1	R1	R0	Select 1 out of 4 line ( in DDRAM) and decide whether to reverse the display by toggling this instruction <b>R1,R0 initial value is 00</b>	72 us
EXTENDED FUNCTION SET	0	0	0	0	1	DL	X	1	RE	G	0	DL=1 8-BIT interface DL=0 4-BIT interface <b>RE=1: extended instruction set</b> <b>RE=0: basic instruction set</b> G=1 :graphic display ON G=0 :graphic display OFF	72 us
SET IRAM or SCROLL ADDR	0	0	0	1	AC5	AC4	AC3	AC2	AC1	AC0		SR=1: AC5~AC0 the address of vertical scroll SR=0: AC3~AC0 the address of ICON RAM	72 us
SET GRAPHIC RAM ADDR.	0	0	1	0	0	0	AC3	AC2	AC1	AC0	AC0	Set GDRAM address to address counter ( AC ) First set vertical address and the horizontal address by consecutive writing Vertical address range AC5...AC0 Horizontal address range AC3... AC0	72 us

## 2.5 Inspection Specification

- ◆ Inspection Standard : MIL-STD-105E Table Normal Inspection Single Sampling Level II .
- ◆ Equipment : Gauge、MIL-STD、Powertip Tester、Sample
- ◆ Defect Level : Major Defect AQL 0.4; Minor Defect AQL 1.5 .
- ◆ OUT Going Defect Level : Sampling .
- ◆ Manner of appearance test :
  - (1). The test be under 40W×2 fluorescent light ' and distance of view must be at 30 cm.
  - (2). The test direction is base on about around 45° of vertical line. (Fig. 1)
  - (3). Definition of area . (Fig. 2)

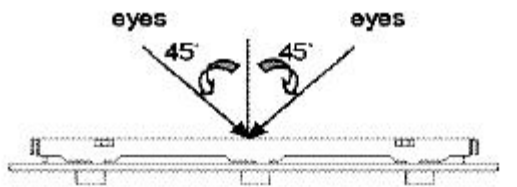

**B area : Outside of viewing area**

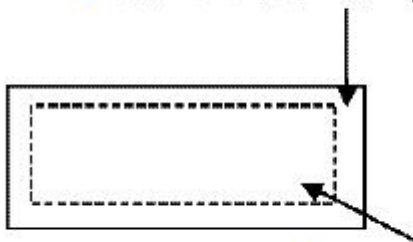

**A area : viewing area**

◆ Specification:

NO	Item	Criterion	level
01	Product condition	1.1 The part number is inconsistent with work order of Production.	Major
		1.2 Mixed production types.	Major
		1.3 Assembled in inverse direction.	Major
02	Quantity	2.1 The quantity is inconsistent with work order of production.	Major
03	Outline dimension	3.1 Product dimension and structure must conform to Structure diagram.	Major
04	Electrical Testing	4.1 Missing line character、dot and icon.	Major
		4.2 No function or no display.	Major
		4.3 Output data is error.	Major
		4.4 LCD viewing angle defect.	Major
		4.5 Current consumption exceeds product specifications.	Major
05	Black or white dot、scratch、contamination Round type	5.1 Round type: 5.1.1 display only : • White and black spots on display $\leq 0.25\text{mm}$ , no more than Four white or black spots present. • Densely spaced : NO more than two spots or lines within 3mm	Minor

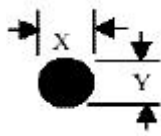
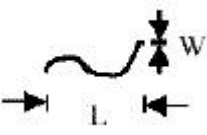

◆ Specification :

NO	Item	Criterion	level
05	<p>Black or white dot、scratch、contamination Round type</p>  <p><math>\Phi = (x+y)/2</math></p> 	<p>5.1.2 Nom-display :</p> <p>Dimension (diameter : <math>\Phi</math>) Acceptance(Q'ty)</p> <p><math>\Phi \leq 0.10\text{mm}</math> Accept no dense</p> <p><math>0.10\text{mm} &lt; \Phi \leq 0.20\text{mm}</math> 3</p> <p><math>0.20\text{mm} &lt; \Phi \leq 0.25\text{mm}</math> 2</p> <p>Total 4</p> <p>5.1.3 Line type: Dimension (diameter : <math>\Phi</math>) Acceptance (Q'ty)</p> <p>Length width A area B area ---</p> <p><math>w \leq 0.03\text{mm}</math> Accept no dense Don't count</p> <p><math>L \leq 3.0\text{mm}</math> <math>0.03\text{mm} &lt; \Phi \leq 0.05\text{mm}</math> 4</p> <p>Don't count</p> <p><math>L \leq 2.5\text{mm}</math> <math>0.05\text{mm} &lt; \Phi \leq 0.075\text{mm}</math></p> <p>Don't count</p> <p>---</p> <p><math>w &gt; 0.075\text{mm}</math> As round type</p>	<p>Minor</p>

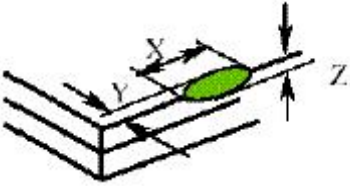

<p>06</p>	<p>Polarizer Bubble</p>	<p>Dimension (diameter : <math>\Phi</math>)</p> <p>A area</p> <p>Acceptance(Q'ty)</p> <p>B area  <math>\Phi \leq 0.20\text{mm}</math>          Accept no dense          Don't count</p> <p><math>0.20\text{mm} &lt; \Phi \leq 0.50\text{mm}</math>          3          Don't count</p> <p><math>0.50\text{mm} &lt; \Phi \leq 1.00\text{mm}</math>          2          Don't count</p> <p><math>\Phi &gt; 1.00\text{mm}</math>          0          Don't count</p> <p>Total quantity          4          Don't count</p>	<p>Minor</p>
<p>07</p>	<p>The crack of glass</p>	<p>● Glass Crack:          7.1 Crack on the circuit of electrode terminal :</p>  <p>X          Y          Z</p> <p>Front  <math>X \leq 1/5 a</math>  <math>Y \leq 1/2 D</math>  <math>Z \leq t</math></p> <p>Back</p> <p>Neglect</p>	<p>Minor</p>

◆ Specification :

NO	Item	Criterion	Level
07	<p>The crack of glass</p> <p>X: The length of Crack</p> <p>Y: The width of crack</p> <p>Z: The thickness of crack</p> <p>D: terminal length</p> <p>T: The thickness of glass</p> <p>A : The length of glass</p>	<p>● Glass Crack:</p> <p>7.2 General glass crack and corner edge:</p> <p>7.2.1</p>  <p>X Y Z Neglect Out A area Neglect</p> <p>7.2.2</p>  <p>X Y Z Neglect Out A area Neglect</p>	Minor

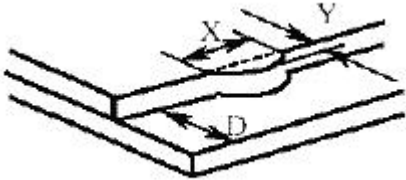
		<p>7.3 Glass remain:</p>  <p>X Y</p> <p>Neglect <math>\leq 1/3 d</math></p>	<p>Minor</p>
--	--	---	--------------

◆ Specification :

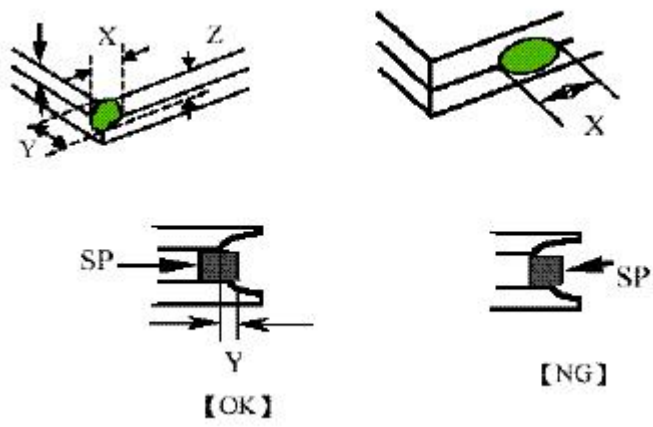
NO	Item	Criterion	Level
07	<p>The crack of glass</p> <p>X: The length of Crack</p> <p>Y: The width of crack</p> <p>Z: The thickness of crack</p> <p>D: terminal length</p> <p>T: The thickness of glass</p> <p>A : The length of glass</p>	<p>7.4 Corner crack and medial crack:</p>  <p>X Y Z</p> <p><math>\cong 1/5a</math></p> <p>Crack can't enter viewing area <math>\cong 1/2t</math> <math>\cong 1/5a</math></p> <p>Crack can't exceed the half of width of SP width of SP <math>1/2t &lt; Z \cong 2t</math></p>	<p>Minor</p>
08	<p>Backlight elements</p>	<p>8.1 Backlight can't work normally.</p> <p>8.2 Backlight doesn't light or color is wrong.</p>	<p>Major</p> <p>Major</p>



# THINGWELL ELECTRONICS

TEL:+86-755-27435731 FAX:+86-755-27132381

<http://www.lcdmaker.com>

		8.3 Illumination source flickers when lit.	Major
09	General appearance	9.1 pin type must match type in specification sheet	Major
		9.2 No short circuits in components on PCB or FPC	Major
		9.3 Product packaging must be the same as specified on packaging specification sheet.	Major
		9.4 The folding and peeling off in polarizer are not acceptable	Major
		9.5 The PCB or FPC between B/L assembled distance (PCB or FPC) is $\leq 1.5\text{mm}$	Major