



Goldenvision Shenzhen Display Co., Ltd

# **SPECIFICATION FOR APPROVAL**

**Product Type : Character Type STN Dot Matrix  
LCD Module**

**Part No. : GV2402A**

## **APPOVED SIGNATURES**

| Leo Cheng | Customer |
|-----------|----------|
|           |          |

- 1 . REVISION RECORD
2. **GENERAL SPECIFICATION**
3. OUTLINE DEMENSION:
4. BLOCK DIAGRAM
5. ABSOLUTE MAXIMUM RATINGS
6. ELECTRICAL CHARACTERISTICS
7. ABSOLUTE MAXIMUM RATINGS FOR LED BACKLIGHT
8. PIN ASSIGNMENT
9. MPU INTERFACE
10. REFLECTOR OF SCREEN AND DIPLAY RAM
11. DISPLAY CONTROL INSTRUCTION
- 12.OPTICAL CHARACTERISTICS
13. POWER SUPPLY SCHEMATICS
14. APPLICATION EXAMPLE
15. PRECAUTION FOR USING LCM

**1. REVISION RECORD**

| <b>REV</b> | <b>DATA</b> | <b>PAGES</b> | <b>DESCRIPTION</b> |
|------------|-------------|--------------|--------------------|
|            |             |              |                    |

## 2 .GENERAL SPECIFICATION

Interface with 4-bit or 8-bit MPU (directly connected M6800 serial MPU)

### **Display Specification**

Display Character: 24 character X 2 line Character Font:5X8dots+cursor

Display color-Display background color : STN, Black-Yellow/Green

Polarize mode: positive, Reflective

Viewing angle: 6:00

Display duty: 1/16 Driving bias: 1/5

Character Generator ROM (CGROM): 8320 bits (192 characterX5X8 dots) &(32 characterX5X10 dots)

Character Generator RAM (CGRAM): 64X8 bits (8 charactersX5X8 dots)

Display Data RAM (DDRAM) :48X8 bits (80 characters max)

### **Mechanical characteristics (Unit : mm)**

Extenal dimension: 118.0X36.0X13.0

View area :934 X16.0

Character font: 5X8 dots + cursor

Character size: 3.2X5.55

Dots size:0.6X0.65

Character pitch: 3.7 X5.95

**Weight: g**

POWER: +5V

**3. OUTLINE  
DEMENSION :**

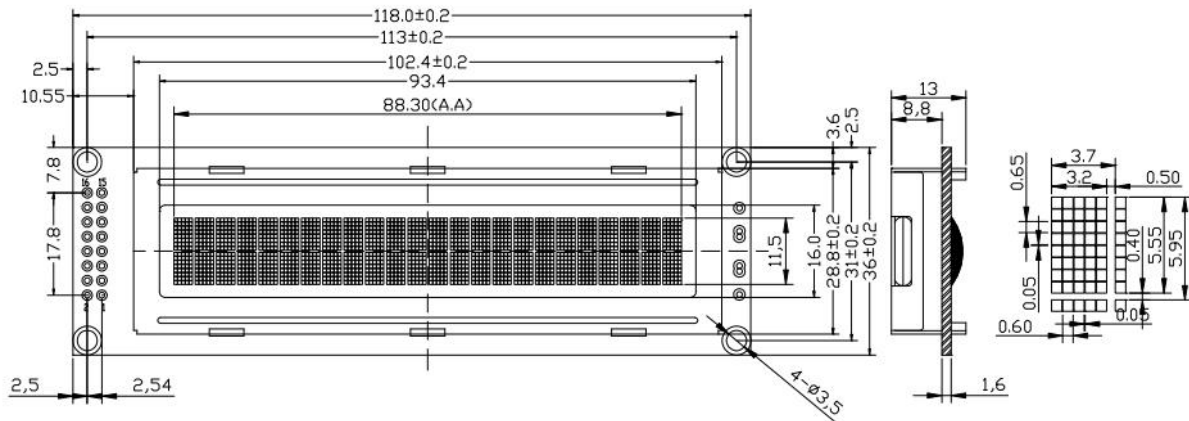

**4. BLOCK DIAGRAM :**

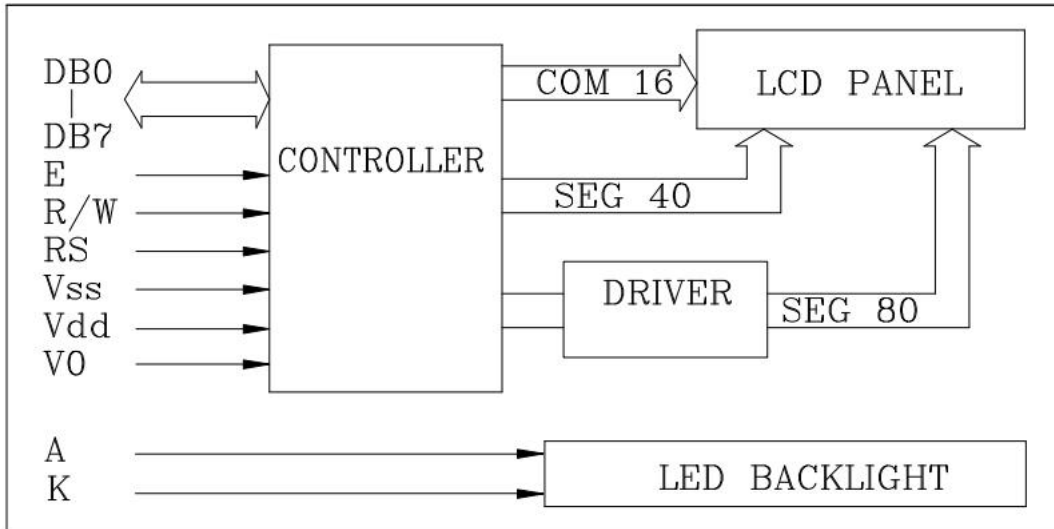

**5. Absolute Maximum Ratings**

| Item                     | Symbol | Condition | Standard Value |         | Unit |
|--------------------------|--------|-----------|----------------|---------|------|
|                          |        |           | Min            | Max     |      |
| Supply Voltage for logic | Vdd    |           | -0.3           | 7.°     | V    |
| Supply Voltage for LCD   | V5     |           | Vdd-1°.        | Vdd+°.3 | V    |
| Input Voltage            | Vi     |           | -0.3           | Vdd+°.3 | V    |
| Operating Temperature(T) | Top    | -         | -2°            | 7°      | °C   |
| Storage Temperature(T)   | Tstg   | -         | -3°            | 8°      | °C   |

**6. ELECTRICAL SPECIFICATIONS(Ta=25°C,Vdd=5 .0V)**

| Item                     | Symbol  | Condition   | Standard Value |      |     | Unit |
|--------------------------|---------|-------------|----------------|------|-----|------|
|                          |         |             | Min            | Type | Max |      |
| Supply Voltage for logic | Vdd-GND | -           | 4.5            | 5.°  | 5.5 | V    |
| Supply Current for logic | Idd     | Vdd=5V      | -              | 1.°  | -   | mA   |
| Driving Current for LCD  | Iee     |             | -              | °.6  | -   | mA   |
| Driving Voltage for LCD  | Vdd-V5  |             | 4.5            | 4.8  | 5.° | V    |
| Input Voltage H level    | Vih     |             | 2.2            | -    | Vdd | V    |
| Input Voltage L level    | Vil     |             | -°.3           | -    | °.6 | V    |
| Output Voltage H         | Voh     | Ioh=-°.25mA | 2.4            | -    | -   | V    |
| Output Voltage L         | Vol     | Iol=1.2mA   | -              | -    | °.4 | V    |

**7. Absolute Maximum Ratings For Bottom LED Backlight**

| Parameter                       | Symbol | Test condition     | Min | Type | Max | Unit |
|---------------------------------|--------|--------------------|-----|------|-----|------|
| LED Forward Consumption Current | If     | Ta=25°C<br>Vf=4.2V | -   | °    | °   | mA   |
| LED Allowable Dissipation       | Pd     |                    | -   | °    | °   | mW   |

**8. Pin assignment**

| Pin NO. | Symbol | Function                                 |         | Remark   |
|---------|--------|------------------------------------------|---------|----------|
| 1       | Vss    | Power Supply                             | °V      |          |
| 2       | Vdd    |                                          | +5V     |          |
| 3       | Vo     |                                          | For LCD | Variable |
| 4       | RS     | Register Select (H: Data L: Instruction) |         |          |
| 5       | R/W    | L: MPU to LCM H: LCM to MPU              |         |          |
| 6       | E      | Enable                                   |         |          |
| 7       | DB°    | Data Bit °                               |         |          |
| 8       | DB1    | Data Bit 1                               |         |          |
| 9       | DB2    | Data Bit 2                               |         |          |
| 1°      | DB3    | Data Bit 3                               |         |          |
| 11      | DB4    | Data Bit 4                               |         |          |
| 12      | DB5    | Data Bit 5                               |         |          |

|    |     |                     |  |
|----|-----|---------------------|--|
| 13 | DB6 | Data Bit 6          |  |
| 14 | DB7 | Data Bit 7          |  |
| 15 | A   | Anode of LED Unit   |  |
| 16 | K   | Cathode of LED Unit |  |



9. MPU Interface (Vdd=4.5V ~ 5.5V, Ta=-30 ~ +85°C)

| Mode       | Characteristic            | Symbol                         | Min. | Type | Max | Unit |
|------------|---------------------------|--------------------------------|------|------|-----|------|
| Write Mode | E Cycle Time              | t <sub>c</sub>                 | 500  | -    | -   | ns   |
|            | E Rise/Fall Time          | t <sub>R</sub> ,t <sub>F</sub> | -    | -    | 20  |      |
|            | E Pulse Width (High, Low) | t <sub>pW</sub>                | 230  | -    | -   |      |
|            | R/W and RS Setup time     | t <sub>spi</sub>               | 40   | -    | -   |      |
|            | R/W and RS Hold Time      | t <sub>HD1</sub>               | 10   | -    | -   |      |
|            | Data Setup Time           | t <sub>sP2</sub>               | 80   | -    | -   |      |
|            | Data Hold Time            | t <sub>HD2</sub>               | 10   | -    | -   |      |
| Read Mode  | E Cycle Time              | t <sub>c</sub>                 | 500  | -    | -   | ns   |
|            | E Rise/Fall Time          | t <sub>R</sub> ,t <sub>F</sub> | -    | -    | 20  |      |
|            | E Pulse Width(High, Low)  | t <sub>pW</sub>                | 230  | -    | -   |      |
|            | R/W and RS Setup Time     | t <sub>spi</sub>               | 40   | -    | -   |      |
|            | R/W and RS Hold Time      | t <sub>HD2</sub>               | 10   | -    | -   |      |
|            | Data Output Delay Time    | t <sub>D</sub>                 | -    | -    | 120 |      |
|            | Data Hold Time            | t <sub>HD2</sub>               | 5    | -    | -   |      |

IC Specifications

See The Reference of SAMSUNG Data Book-----S6A0069

Timing diagram

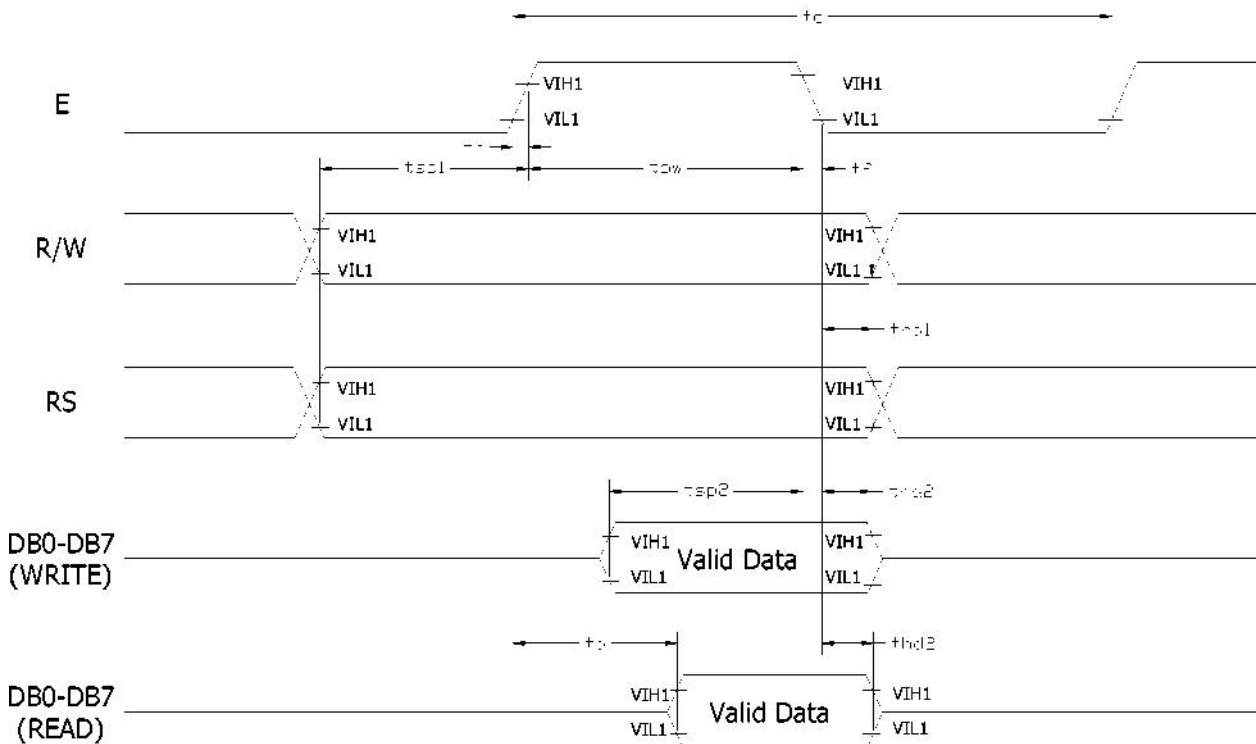

**10. Reflector of Screen and Display RAM**

|                  |      |      |      |      |      |      |      |      |      |      |
|------------------|------|------|------|------|------|------|------|------|------|------|
| Display position | 1-1  | 1-2  | 1-3  | 1-4  | 1-5  | 1-6  | 1-7  | 1-8  | 1-9  | 1-10 |
| DDRAM address    | 00   | 01   | 02   | 03   | 04   | 05   | 06   | 07   | 08   | 09   |
| Display position | 1-11 | 1-12 | 1-13 | 1-14 | 1-15 | 1-16 | 1-17 | 1-18 | 1-19 | 1-20 |
| DDRAM address    | 0A   | 0B   | 0C   | 0D   | 0E   | 0F   | 10   | 11   | 12   | 13   |
| Display position | 1-21 | 1-22 | 1-23 | 1-24 |      |      |      |      |      |      |
| DDRAM address    | 14   | 15   | 16   | 17   |      |      |      |      |      |      |
| Display position | 2-1  | 2-2  | 2-3  | 2-4  | 2-5  | 2-6  | 2-7  | 2-8  | 2-9  | 2-10 |
| DDRAM address    | 40   | 41   | 42   | 43   | 44   | 45   | 46   | 47   | 48   | 49   |
| Display position | 2-11 | 2-12 | 2-13 | 2-14 | 2-15 | 2-16 | 2-17 | 2-18 | 2-19 | 2-20 |
| DDRAM address    | 4A   | 4B   | 4C   | 4D   | 4E   | 4F   | 50   | 51   | 52   | 53   |
| Display position | 2-21 | 2-22 | 2-23 | 2-24 |      |      |      |      |      |      |
| DDRAM address    | 54   | 55   | 56   | 57   |      |      |      |      |      |      |

**-1 means first character of line 1 on screen**

**11. DISPLAY CONTROL INSTRUCTION**

| Instruction                | Instruction Code |     |     |     |     |     |     |     |     |     | Description | ExecutionTime(fosc=270kHz)                                                                                                                           |        |
|----------------------------|------------------|-----|-----|-----|-----|-----|-----|-----|-----|-----|-------------|------------------------------------------------------------------------------------------------------------------------------------------------------|--------|
|                            | RS               | R/W | DB7 | DB6 | DB5 | DB4 | DB3 | DB2 | DB1 | DB0 |             |                                                                                                                                                      |        |
| Clear Display Return Home  | 0                | 0   | 0   | 0   | 0   | 0   | 0   | 0   | 0   | 0   | 1           | Write "20H" to DDRAM set DDRAM address to "00H" from AC and return cursor to its original position if shifted. The contents of DDRAM are not changed | 1.52ms |
| Entry Mode Set             | 0                | 0   | 0   | 0   | 0   | 0   | 0   | 1   | I/D | SH  |             | Assign cursor moving direction and enable the shift of entire display                                                                                | 38 μs  |
| Display ON/OFF Control     | 0                | 0   | 0   | 0   | 0   | 0   | 1   | D   | C   | B   |             | Set display (D) cursor(C) and blinking of cursor(B) on/off                                                                                           | 38 μs  |
| Cursor or Display Shift    | 0                | 0   | 0   | 0   | 0   | 1   | S/C | R/L | -   | -   |             | Set cursor moving and display shift control bit, and the direction, without changing DDRAM data                                                      | 38 μs  |
| Function Set               | 0                | 0   | 0   | 0   | 1   | DL  | N   | F   | -   | -   |             | Set interface data length of display line (N:2line/1line)and, display font type F :5X11dots/5X8dots                                                  | 38 μs  |
| Set CGRAM Address          | 0                | 0   | 0   | 1   | AC5 | AC4 | AC3 | AC2 | AC1 | AC0 |             | Set CGRAM address in address counter                                                                                                                 | 38 μs  |
| Set DDRAM Address          | 0                | 0   | 1   | AC6 | AC5 | AC4 | AC3 | AC2 | AC1 | AC0 |             | Set DDRAM address in address counter                                                                                                                 | 38 μs  |
| Read Busy Flag and Address | 0                | 1   | BF  | AC6 | AC5 | AC4 | AC3 | AC2 | AC1 | AC0 |             | Whether during internal operation or not can be known by reading BF The contents of address counter of address counter can also be read              | 0 μs   |
| Write Data to RAM          | 1                | 0   | D7  | D6  | D5  | D4  | D3  | D2  | D1  | D0  |             | Write data into internal RAM (DDRAM/CGRAM)                                                                                                           | 38 μs  |
| Read data from RAM         | 1                | 1   | D7  | D6  | D5  | D4  | D3  | D2  | D1  | D0  |             | Read data from internal RAM (DDRAM/CGRAM)                                                                                                            | 38 μs  |

**Clear Display**

| RS | R/W | DB7 | DB6 | DB5 | DB4 | DB3 | DB2 | DB1 | DB0 |
|----|-----|-----|-----|-----|-----|-----|-----|-----|-----|
| 0  | 0   | 0   | 0   | 0   | 0   | 0   | 0   | 0   | 1   |

**Instruction Description**

Clear all the display data by writing "20H" (space code) to all DDRAM address, and set DDRAM address to "00H" into AC(address counter).Return cursor to the original status, namely, bring the cursor to the left edge on the first line of the display. Make the entry mode increment(I/D=HIGH)

**Return Home**

| RS | R/W | DB7 | DB6 | DB5 | DB4 | DB3 | DB2 | DB1 | DB0 |
|----|-----|-----|-----|-----|-----|-----|-----|-----|-----|
| 0  | 0   | 0   | 0   | 0   | 0   | 0   | 0   | 1   | -   |

Set DDRAM address to "00H" into the address counter. Return cursor to its original site and return display to its original status, if shifted. Contents of DDRAM do not change.

## Entry Mode Sei

|    |     |     |     |     |     |     |     |     |     |
|----|-----|-----|-----|-----|-----|-----|-----|-----|-----|
| RS | R/W | DB7 | DB6 | DB5 | DB4 | DB3 | DB2 | DB1 | DB0 |
| 0  | 0   | 0   | 0   | 0   | 0   | 0   | 1   | I/D | SH  |

Set the moving direction of cursor and display.

### I/D : Increment/decrement of DDRAM address (cursor or blink)

When I/D=High, cursor/blink moves to right and DDRAM address is increased by 1.

When I/D=low, cursor/blink moves to left and DDRAM address is decreased by 1.

\*CGRAM operates the same as DDRAM, when reading from or writing to CGRAM.

### SH : Shift of entire display

When DDRAM read (CGRAM read/write) operation or SHD<sup>^</sup>LOW", shifting of entire display is not performed. If SH=High, and DDRAM write operation, shift of entire display is performed according to I/D value(I/D=High, shift left, I/D=Low, shift right).

## Display ON/OFF Control

|    |     |     |     |     |     |     |     |     |     |
|----|-----|-----|-----|-----|-----|-----|-----|-----|-----|
| RS | R/W | DB7 | DB6 | DB5 | DB4 | DB3 | DB2 | DB1 | DB0 |
| 0  | 0   | 0   | 0   | 0   | 0   | 1   | D   | C   | B   |

### D : Display ON/OFF control bit

When D=High, entire display is turned on.

When D=Low, display is turned off, but display data remains in DDRAM.

### C : Cursor ON/OFF control bit

When C=High, cursor is turned on.

When C=Low, cursor is disappeared in current display, but I/D register preserves its data.

### B : Cursor Blink ON/OFF control bit

When B=High, cursor blink is on, which performs alternately between all the high data and display characters at the cursor position. When B=Low, Blink is off.

## Cursor or Display Shift

|    |     |     |     |     |     |     |     |     |     |
|----|-----|-----|-----|-----|-----|-----|-----|-----|-----|
| RS | R/W | DB7 | DB6 | DB5 | DB4 | DB3 | DB2 | DB1 | DB0 |
| 0  | 0   | 0   | 0   | 0   | 1   | S/C | R/L | -   | -   |

Shifting of right/left cursor position or display without writing or reading of display data. This instruction is used to correct or search display data. During 2-line mode display, cursor moves to the 2<sup>nd</sup> line after the 40<sup>th</sup> digit of the 1<sup>st</sup> line. Note that display shift is performed simultaneously in all the lines. When displayed data is shifted repeatedly, each line is shifted individually. When display shift is performed, the contents of the address counter are not changed.

| S/C | R/L | Operation                                                                 |
|-----|-----|---------------------------------------------------------------------------|
| 0   | 0   | Shift cursor to the left, AC is decreased by 1                            |
| 0   | 1   | Shift cursor to the right, AC is increased by 1                           |
| 1   | 0   | Shift all the display to the left, Cursor moves according to the display  |
| 1   | 1   | Shift all the display to the right, cursor moves according to the display |

## Function set

|    |     |     |     |     |     |     |     |     |     |
|----|-----|-----|-----|-----|-----|-----|-----|-----|-----|
| RS | R/W | DB7 | DB6 | DB5 | DB4 | DB3 | DB2 | DB1 | DB0 |
| 0  | 0   | 0   | 0   | 1   | DL  | N   | F   | -   | -   |

### DL : Interface data length control bit

When DL=High, it means 8-bit bus mode with MPU.

When DL=Low, it means 4-bit bus mode with MPU. When 4-bit bus mode, it needs to transfer 4-bit data twice.

### N : Display line number control bit

When N=Low, 1-line display mode is set.

When N=High, 2-line display mode is set.

### F : Display font type control bit

When F=Low, 5X8 dots format display mode is set.

When F=High, 5X11 dots format display mode.

## Set CGRAM Address

| RS | R/W | DB7 | DB6 | DB5 | DB4 | DB3 | DB2 | DB1 | DB0 |
|----|-----|-----|-----|-----|-----|-----|-----|-----|-----|
| 0  | 0   | 0   | 1   | AC5 | AC4 | AC3 | AC2 | AC1 | AC0 |

Set CGRAM address to AC. This instruction makes CGRAM data available from MPU.

## Set DDRAM Address

| RS | R/W | DB7 | DB6 | DB5 | DB4 | DB3 | DB2 | DB1 | DB0 |
|----|-----|-----|-----|-----|-----|-----|-----|-----|-----|
| 0  | 0   | 1   | AC6 | AC5 | AC4 | AC3 | AC2 | AC1 | AC0 |

Set DDRAM address to AC. This instruction makes DDRAM data available from MPU. When 1-line display mode (N=Low), DDRAM address is from "OOH" to "4FH". In 2-line display mode (N=High), DDRAM address in the 1st line is from "OOH" to "27H" and DDRAM address in the 2nd line is from "40H" to "67H".

## Read Busy Flag & Address

| RS | R/W | DB7 | DB6 | DB5 | DB4 | DB3 | DB2 | DB1 | DB0 |
|----|-----|-----|-----|-----|-----|-----|-----|-----|-----|
| 0  | 1   | BF  | AC6 | AC5 | AC4 | AC3 | AC2 | AC1 | AC0 |

This instruction shows whether IC is in internal operation or not. If BF is high internal operation is in progress and should wait until BF is to be Low, which by then the next instruction can be performed. In this instruction you can also read the value of the address counter.

## Write data to RAM

| RS | R/W | DB7 | DB6 | DB5 | DB4 | DB3 | DB2 | DB1 | DB0 |
|----|-----|-----|-----|-----|-----|-----|-----|-----|-----|
| 1  | 0   | D7  | D6  | D5  | D4  | D3  | D2  | D1  | D0  |

Write binary 8-bit data to DDRAM/CGRAM. The selection of RAM from DDRAM, and CGRAM, is set by the previous address set instruction (DDRAM address set, CGRAM address set). RAM set instruction can also determine the AC direction to RAM. After write operation, the address is automatically increased/decreased by 1, according to the entry mode.

## Read data from RAM

| RS | R/W | DB7 | DB6 | DB5 | DB4 | DB3 | DB2 | DB1 | DB0 |
|----|-----|-----|-----|-----|-----|-----|-----|-----|-----|
| 1  | 1   | D7  | D6  | D5  | D4  | D3  | D2  | D1  | D0  |

Read binary 8-bit data from DDRAM/CGRAM. The selection of RAM is set by the previous address set instruction. If the address set instruction of RAM is not performed before this instruction, the data that has been read first is invalid, as the direction of AC is not yet determined. If RAM data is read several times without RAM address instructions set before read operation, the correct RAM data can be obtained from the second. But the first data would be incorrect, as there is no time margin to transfer RAM data. In case of DDRAM read operation, cursor shift instruction plays the same role as DDRAM address set instruction, it also transfers RAM data to output data register. After read operation, address counter is automatically increased/decreased by 1 according to the entry mode.

After CGRAM read operation, display shift may not be executed correctly.

## Note :

In case of RAM write operation, AC is increased/decreased by 1 as in read operation. At this time, AC

indicates the next address position, but only the previous data can be read by the read instruction.

## Relationship between Character Code and CGRAM

| Character code         | CGRAM Address                                                              | CGRAM Data                                                                                                                                    | Pattern number |
|------------------------|----------------------------------------------------------------------------|-----------------------------------------------------------------------------------------------------------------------------------------------|----------------|
| D7 D6 D5 D4 D3 D2D1 D0 | A5 A4 A3 A2 A1 A0                                                          | P7P6P5P4 P3 P2P1P0                                                                                                                            |                |
| 0000x000               | 0 0 0 0 0 0<br>0 0 1<br>0 1 0<br>0 1 1<br>1 0 0<br>1 0 1<br>1 1 0<br>1 1 1 | x x x 0 1 1 1 0<br>x x x 1 0 0 0 0<br>x x x 1 0 0 0 0<br>x x x 0 1 1 1 0<br>x x x 0 0 0 0 1<br>x x x 0 0 0 0 1<br>x x x 0 1 1 1 0<br>xxx00000 | Pattern1       |
| 0 0 0 0 x 1 1 1        | 0 0 0 0 0 0<br>0 0 1<br>0 1 0<br>0 1 1<br>1 0 0<br>1 0 1<br>1 1 0<br>1 1 1 | x x x 0 1 1 1 0<br>x x x 1 0 0 0 1<br>x x x 1 0 0 0 1<br>x x x 1 1 1 1 1<br>x x x 1 0 0 0 1<br>x x x 1 0 0 0 1<br>x x x 1 0 0 0 1<br>xxx00000 | Pattern"       |

## Display Data RAM(DDRAM)

DDRAM stores display data of maximum 80x8bits (80 characters). DDRAM address is set in the address counter (AC) as a hexadecimal number

MSB

LSB

|     |     |     |     |     |     |     |
|-----|-----|-----|-----|-----|-----|-----|
| AC6 | AC5 | AC4 | AC3 | AC2 | AC1 | AC0 |
|-----|-----|-----|-----|-----|-----|-----|

Initializing Flowchart (Condition : fosc=270KHZ)

Power on

| Function set |     |     |     |     |     |     |     |     |     |
|--------------|-----|-----|-----|-----|-----|-----|-----|-----|-----|
| RS           | R/W | DB7 | DB6 | DB5 | DB4 | DB3 | DB2 | DB1 | DB0 |
| 0            | 0   | 0   | 0   | 1   | 1   | N   | F   | X   | X   |

|   |   |             |
|---|---|-------------|
| N | 0 | 1-line mode |
|   | 1 | 2-line mode |
| F | 0 | 5x8 Dots    |
|   | 1 | 5x11 Dots   |

Wait for more than 38  $\mu$  s

| Display ON/OFF Control |     |     |     |     |     |     |     |     |     |
|------------------------|-----|-----|-----|-----|-----|-----|-----|-----|-----|
| RS                     | R/W | DB7 | DB6 | DB5 | DB4 | DB3 | DB2 | DB1 | DB0 |
| 0                      | 0   | 0   | 0   | 0   | 0   | 1   | D   | C   | B   |

|   |   |             |
|---|---|-------------|
| D | 0 | Display off |
|   | 1 | Display on  |
| D | 0 | Cursor off  |
|   | 1 | Cursor on   |
| B | 0 | Blink off   |
|   | 1 | Blink on    |

Wait for more than 38  $\mu$  s

Wait for more than 30ms after Vdd rises to 4.5V

| Display Clear |     |     |     |     |     |     |     |     |     |
|---------------|-----|-----|-----|-----|-----|-----|-----|-----|-----|
| RS            | R/W | DB7 | DB6 | DB5 | DB4 | DB3 | DB2 | DB1 | DB0 |
| 0             | 0   | 0   | 0   | 0   | 0   | 0   | 0   | 0   | 1   |

Wait for more than 1.52ms

| Entry Mode Set |     |     |     |     |     |     |     |     |     |
|----------------|-----|-----|-----|-----|-----|-----|-----|-----|-----|
| RS             | R/W | DB7 | DB6 | DB5 | DB4 | DB3 | DB2 | DB1 | DB0 |
| 0              | 0   | 0   | 0   | 0   | 0   | 0   | 1   | I/D | SH  |

|     |   |                  |
|-----|---|------------------|
| I/D | 0 | Decrement mode   |
|     | 1 | Increment mode   |
| SH  | 0 | Entire shift off |
|     | 1 | Entire shift on  |

Initialization End

!.OPTICAL CHARACTERISTICS :

| ITEM          | SYMBOL | CONDITION              | MIN. | TYP. | MAX. | UNIT | REF. |
|---------------|--------|------------------------|------|------|------|------|------|
| Contrast      | CR     | 25°C, Vdd=5V, 9=0, 0=0 | --   | 4    | --   |      | (2)  |
| Rise Time     | Tr     | 25°C, Vdd=5V, 9=0, 0=0 | --   | 160  | 240  | ms   | (3)  |
| Fall Time     | Tf     | 25 C, Vdd=5V, 9=0, 0=0 | --   | 100  | 150  | ms   | (3)  |
| Viewing Angle | 9 1-92 | 25 C                   | --   | --   | 60   | DEG  | (1)  |
|               | 01, 02 |                        | -40  | --   | 40   |      |      |

(1) Definition of viewing Angle:

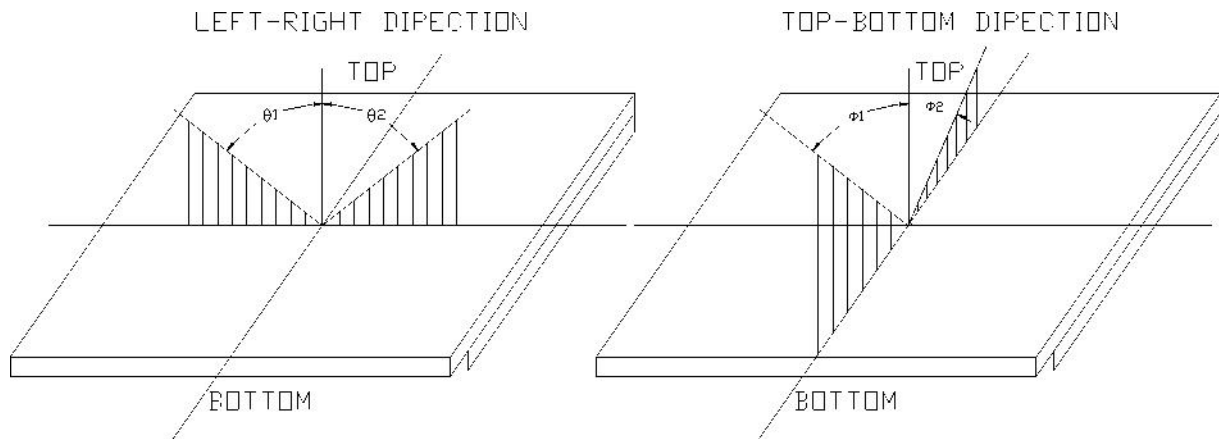

(2) Definition of Contrast Ratio:

$$\text{Contrast Ratio} = \frac{\text{Brightness of non-selected condition}}{\text{Brightness of selected condition}}$$

Test condition: standard A light source

(3) Response Time:

Response time is measured as the shortest period of possible between the change in state of an LCD segments as demonstrated below



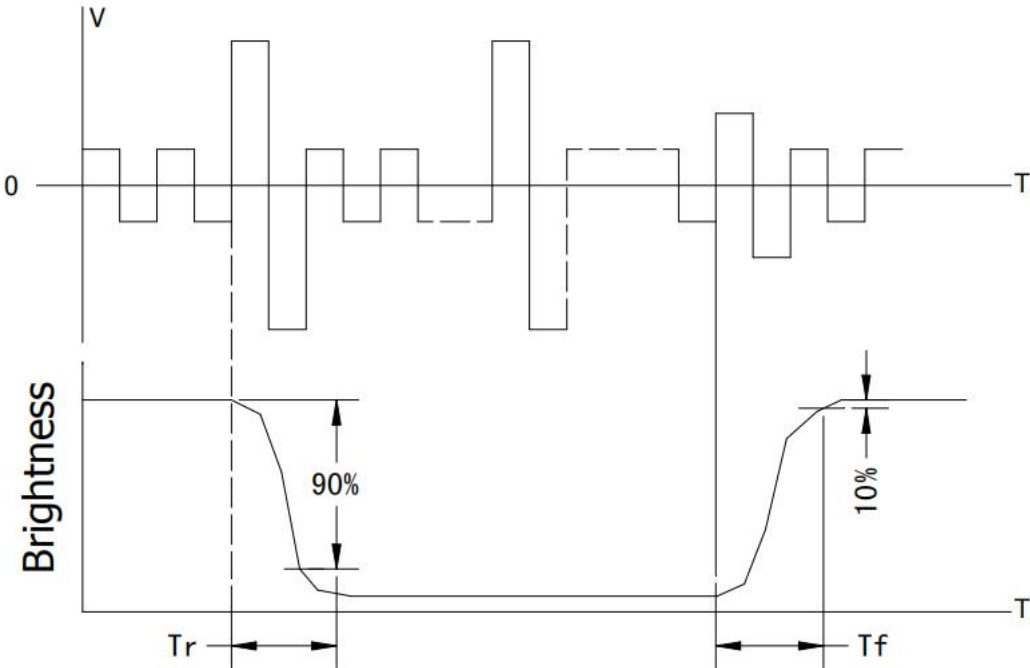

**13.POWER SUPPLY SCHEMATICS**

For Single Source

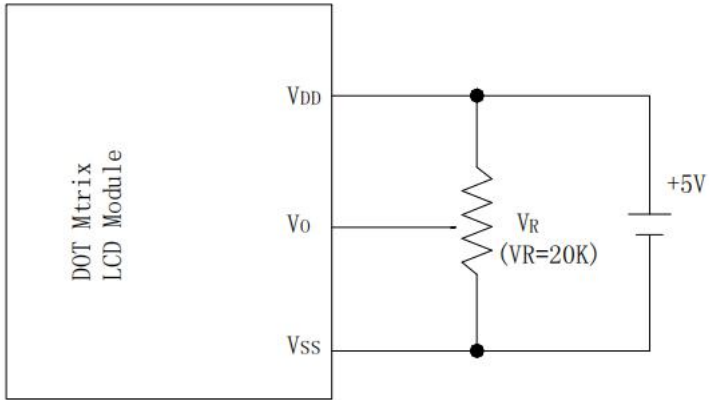

**14. APPLICATION EXAMPLE**

**Application Circuit**

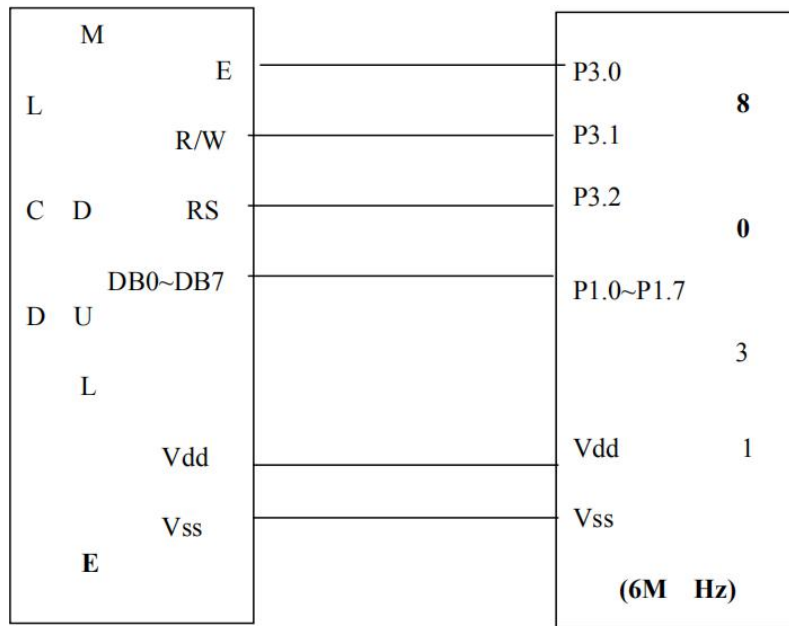

**Application Flowchart**

| Upper<br>4bit<br>Lower<br>4bit | LLLL | LLLH | LLHL    | LLHH | LHLL | LHLH | LHHL | LHHH | HLLL | HLLH | HHLH | HLHH | HLLL | HLLH | HHLH | HHHL | HHHH    |
|--------------------------------|------|------|---------|------|------|------|------|------|------|------|------|------|------|------|------|------|---------|
| LLLL                           |      |      | 00P`P   |      |      |      |      |      |      |      |      |      |      |      |      |      | 一93op   |
| LLLH                           |      |      | !1A0a4  |      |      |      |      |      |      |      |      |      |      |      |      |      | 。77434  |
| LLHL                           |      |      | "2BRbr  |      |      |      |      |      |      |      |      |      |      |      |      |      | 「4」×p8  |
| LLHH                           |      |      | #3CScs  |      |      |      |      |      |      |      |      |      |      |      |      |      | 」07E3w  |
| LHLL                           |      |      | \$4DTdt |      |      |      |      |      |      |      |      |      |      |      |      |      | 、I14μa  |
| LHLH                           |      |      | %5EUeu  |      |      |      |      |      |      |      |      |      |      |      |      |      | ・才10ū   |
| LHHL                           |      |      | &6FUFU  |      |      |      |      |      |      |      |      |      |      |      |      |      | 0023p2  |
| LHHH                           |      |      | '7GWgw  |      |      |      |      |      |      |      |      |      |      |      |      |      | 7777g7a |
| HLLL                           |      |      | (8HXhx  |      |      |      |      |      |      |      |      |      |      |      |      |      | イ0717x  |
| HLLH                           |      |      | )9IYiy  |      |      |      |      |      |      |      |      |      |      |      |      |      | 0716'y  |
| HLHL                           |      |      | *:JZjz  |      |      |      |      |      |      |      |      |      |      |      |      |      | E016j7  |
| HLHH                           |      |      | +;KkKk  |      |      |      |      |      |      |      |      |      |      |      |      |      | 0710'7  |
| HHLL                           |      |      | ,<L¥ll  |      |      |      |      |      |      |      |      |      |      |      |      |      | 770777  |
| HHLH                           |      |      | =MmM    |      |      |      |      |      |      |      |      |      |      |      |      |      | 770777  |
| HHHL                           |      |      | .>N^n^  |      |      |      |      |      |      |      |      |      |      |      |      |      | 0707'7  |
| HHHH                           |      |      | /?O_Oe  |      |      |      |      |      |      |      |      |      |      |      |      |      | 0707'0  |

## 15. PRECAUTION FOR USING LCM

### 1. Liquid Crystal Display (LCD)

LCD is made up of glass, organic sealant, organic fluid, and polymer based polarizers. The following precautions should be taken when handling,

- (1) . Keep the temperature within range of use and storage. Excessive temperature and humidity could cause polarization degradation, polarizer peel off or bubble.
- (2) . Do not contact the exposed polarizers with anything harder than an HB pencil lead. To clean dust off the display surface. Wipe gently with cotton. Chamoisother soft material soaked in petroleum benzine.
- (3) . Wipe off saliva or water drops immediately. Contact with water over a long period of time may cause polarizer deformation or color fading, while an active LCD with water condensation on its surface will cause corrosion of ITO electrodes.
- (4) . Glass can be easily chipped or cracked from rough handling. especially at corners and edges.
- (5) . Do not drive LCD with DC voltage.

### 2. Liquid Crystal Display Modules

#### 2.1 Mechanical Considerations

LCM are assembled and adjusted with a high degree of precision. Avoid excessive shocks and do not make any alterations or modifications. The following should be noted.

- (1) . Do not tamper in any way with the tabs on the metal frame.
- (2) . Do not modify the PCB by drilling extra holes, changing its outline, moving its components or modifying its pattern.
- (3) . Do not touch the elastomer connector, especially insert an backlight panel (for example, EL).
- (4) . When mounting a LCM make sure that the PCB is not under any tress such as bending or twisting. Elastomer contacts are very delicate and missing pixels could result from slight dislocation of any of the elements.
- (5) . Avoid pressing on the metal bezel, otherwise the elastomer connector could be deformed and lose contact, resulting in missing pie ls.

#### 2.2. Static Electricity

LCM contains CMOS LSI's and the same precaution for such devices should apply, namely

- (1) . The operator should be grounded whenever he/she comes into contact with the module. Never touch any of the conductive parts such as the LSI pads, the copper leads on the PCB and the interface terminals with any parts of the human body.
- (2) . The modules should be kept in antistatic bags or other containers resistant to static for storage.
- (3) . Only properly grounded soldering irons should be used.
- (4) . If an electric screwdriver is used, it should be well grounded and shielded from commutator sparks.
- (5) . The normal static prevention measures should be observed for work clothes and working benches; for the latter conductive (rubber) mat is recommended.
- (6) . Since dry air is inductive to static, a relative humidity of 50-60% is recommended.

#### 2.3. Soldering

- (1) . Solder only to the I/O terminals.
- (2) . Use only soldering irons with proper grounding and no leakage.
- (3) . Soldering temperature:  $280^{\circ}\text{C} \pm 10^{\circ}\text{C}$
- (4) . Soldering time: 3to4 sec.
- (5) . Use eutectic solder with resin flux fill.
- (6) . If flux is used, the LCD surface should be covered to avoid flux spatters. Flux residue should be removed after wards.

#### 2.4. Operation

- (1) . The viewing angle can be adjusted by varying the LCD driving voltage V0.
- (2) . Driving voltage should be kept within specified range; excess voltage shortens display life.
- (3) . Response time increases with decrease in temperature.
- (4) . Display may turn black or dark blue at temperatures above its operational range; this is (however not pressing on the viewing area) may cause the segments to appear "fractured".
- (5) . Mechanical disturbance during operation (such as pressing on the viewing area) may cause the segments to appear "fractured".

## **2.5. Storage**

If any fluid leaks out of a damaged glass cell, wash off any human part that comes into contact with soap and water. Never swallow the fluid. The toxicity is extremely low but caution should be exercised at all the time.

Thanks for your use!