



**冀诚电子**  
GEM-TECH ELECTRONICS

## LCD MODULE SPECIFICATIONS

Customer:
Customer Part No.:
Gem-tech Model Name: GTG-240645V15-FS6L2C
Release Date: 2012-12-5
Customer Approval:
Date:
The above signature represents that the product specifications, testing regulation, and warranty in the specifications are accepted.

**HEBEI GEM-TECH ELECTRONICS CO., LTD.**

No.368 North Xinshi Road, FL.8 Chuangxin BLD P.C.: 050091

Tel.: +86 311 8381 5999, 8381 6999 Fax.: +86 311 8383 1999

<http://www.gemtech-hb.com>

**Confidential**

This information contained herein is the exclusive property of Gem-tech and shall not be distributed, reproduced, or disclosed in whole or in part without prior written permission of Gem-tech. Subject to change without notice.

---

# Contents

1. BASIC SPECIFICATION
2. ABSOLUTE MAXIMUM RATINGS
3. ELECTRICAL & OPTICAL CHARACTERISTICS
4. TIMING CHARACTERISTICS
5. FUNCTION DESCRIPTION& INSTRUCTION SET
6. CHARACTER FONT TABLE
7. DIMENSIONAL OUTLINE
8. QUALITY SPECIFICATION
9. RELIABILITY
10. HANDLING PRECAUTION
11. PRECAUTION FOR USE
12. REVISIONS HISTORY

# 1. BASIC SPECIFICATION

## 1-1 DISPLAY SPECIFICATIONS

- . DISPLAY MODE : FSTN-TRANSFLECTIVE-POSITIVE
- . DISPLAY FORMAT : 240 X 64 DOTS
- . INPUT DATA : 8-BITS PARALLEL DATA INPUT FROM A MPU
- . MULTIPLEXING : 1/64 DUTY
- . VIEWING DIRECTION : 6 O' CLOCK
- . DRIVED IC : T6963C (OR EQV) , KS0086 (OR EQV)
- . BEZEL : 0.6T
- . BACKLIGHT : LED, WHITE
- . OTHERS :

## 1-2. MECHANICAL SPECIFICATION

ITEM	SPECIFICATIONS	UNIT	REMARK
DIMENSIONAL OUTLINE	180.0(W)×65.0(H)×13.0MAX.(T)	mm	*REFERENCE
VIEW AREA	132.0(W)×40.0(H)	mm	DIMENSIONAL
EFFECTIVE V/AREA	127.16(W)×33.88(H)	mm	OUTLINE
NUMBER OF CHARACTERS	240 DOTS ×64 DOTS	--	
DOT PITCH	0.53(W)×0.53(H)	mm	
DOT SIZE	0.49(W)×0.49(H)	mm	

## 1-3 BLOCK DIAGRAM

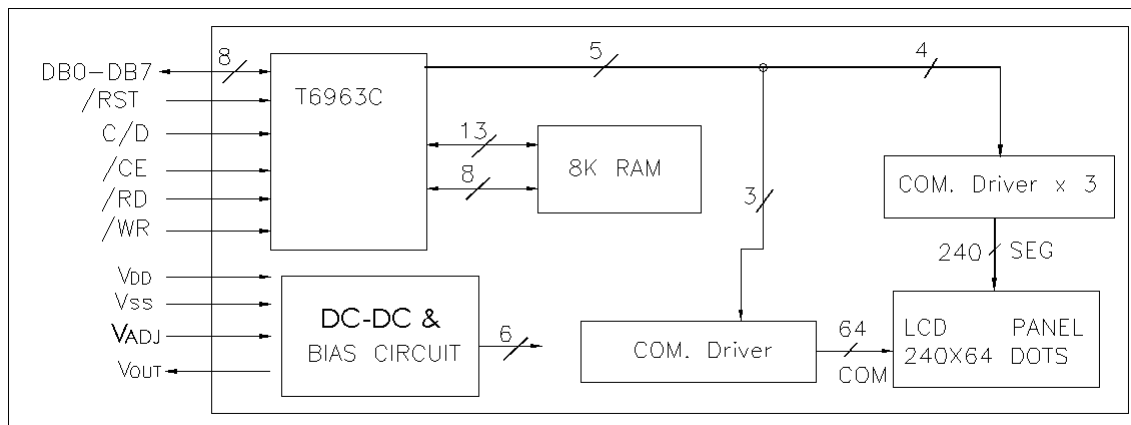

#### 1-4 TERMINAL FUNCTIONS

PIN NO	SYMBOL	LEVEL	DESCRIPTION
1	FG	-	FRAME GROUND
2	V <sub>SS</sub> (GND)	-	GROUND
3	V <sub>DD</sub> (V <sub>CC</sub> )	-	POWER SUPPLY FOR LOGIC
4	V <sub>O</sub>	-	POWER SUPPLY FOR LCD DRIVING
5	/WR	L	COMMAND AND DATA WRITE SIGNAL
6	/RD	L	DATA AND STATUS READ SIGNAL
7	/CE	L	CHIP ENABLE SIGNAL
8	C/D	H/L	WRITE : H:-COMMAND WRITE, L-DATA WRITE READ: H-STATUS READ, L-DATA READ
9	V <sub>out</sub> (V <sub>EE</sub> )	-	NEGATIVE VOLTAGE OUTPUT
10	/RST	L	RESET SIGNAL
11	DB0	H/L	DATA BIT0
12	DB1	H/L	DATA BIT1
13	DB2	H/L	DATA BIT2
14	DB3	H/L	DATA BIT3
15	DB4	H/L	DATA BIT4
16	DB5	H/L	DATA BIT5
17	DB6	H/L	DATA BIT6
18	DB7	H/L	DATA BIT7
19	FS	H/L	FONT SELECTION H: 6X8 DOTS, L: 8X8 DOTS
20	NC	-	
21	A	-	LED BACKLIGHT POWER SUPPLY(+)
22	K	-	LED BACKLIGHT POWER SUPPLY(-)

#### 1-5 POWER SUPPLY CIRCUIT AND CONTRAST ADJUST

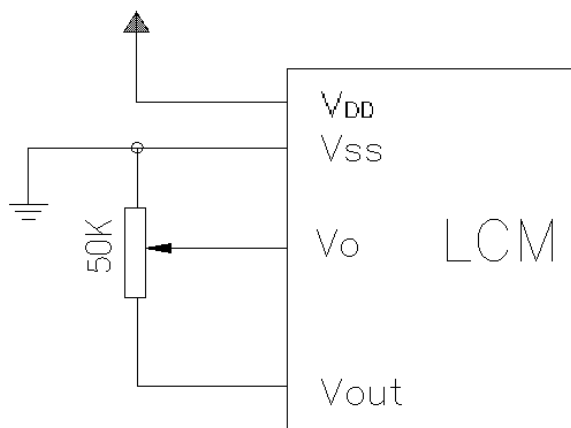

#### 2. ABSOLUTE MAXIMUM RATINGS ( Ta=25°C, V<sub>SS</sub>=0V)

PARAMETER	SYMBOL	RATINGS			UNITS
		MIN.	TYP.	MAX.	
POWER SUPPLY FOR LOGIC	V <sub>DD</sub> -V <sub>SS</sub>	0	-	7.5	V
POWER SUPPLY FOR LCD DRIVER	V <sub>DD</sub> ~V <sub>O</sub>	0	-	18.0	V
INPUT VOLTAGE	V <sub>IN</sub>	V <sub>SS</sub>	-	V <sub>DD</sub>	V
OPERATING TEMPERATURE	T <sub>opr</sub>	-20	-	70	°C
STORAGE TEMPERATURE	T <sub>stg</sub>	-30	-	80	°C

### 3.ELECTRICAL & OPTICAL CHARACTERISTICS

#### 3-1 ELECTRICAL CHARACTERISTICS (Ta=25 °C)

ITEM	SYMBOL	CONDITION	MIN	TYPE	MAX.	UNIT
LOGIC CIRCUIT POWER SUPPLY VOLTAGE	V <sub>DD</sub> -V <sub>SS</sub>	————	4.8	5.0	5.25	V
INPUT VOLTAGE	V <sub>IH</sub>	————	0.7V <sub>DD</sub>	—	V <sub>DD</sub>	V
INPUT VOLTAGE	V <sub>IL</sub>	————	V <sub>SS</sub>	—	0.6	V
LOGIC CIRCUIT POWER SUPPLY CURRENT	I <sub>DD</sub>	V <sub>DD</sub> -V <sub>SS</sub> =5.0V	—	15.0	25.0	mA
RECOMMENDED LCD DRIVING VOLTAGE	V <sub>DD</sub> -V <sub>0</sub> φ=0 θ=0	Ta=25 °C	11.7	12.0	12.3	V
FRAME FREQUENCY	F <sub>film</sub>	-	-	128	-----	Hz

#### 3-2. ELECTRO—OPTICAL CHARACTERISTICS( Ta=25 °C V<sub>DD</sub>=5.0±0.25V VOP=9.0V)

ITEM	SYMBOL	CONDITION	MIN	TYPE	MAX	UNIT
VIEW ANGLE	Δ φ	θ=0°, Cr≥3 -90° < φ <sub>1</sub> , φ <sub>2</sub> < 90°	35	40	—	Deg
CONTRAST	Cr	φ=0°, θ=0°	3	7	—	—
RESPONSE TIME	tr(rise)	φ=0°, θ=0°	—	250	300	ms
	tf(fall)	φ=0°, θ=0°	—	300	350	ms

NOTE1: Definition of Viewing Angle θ, φ

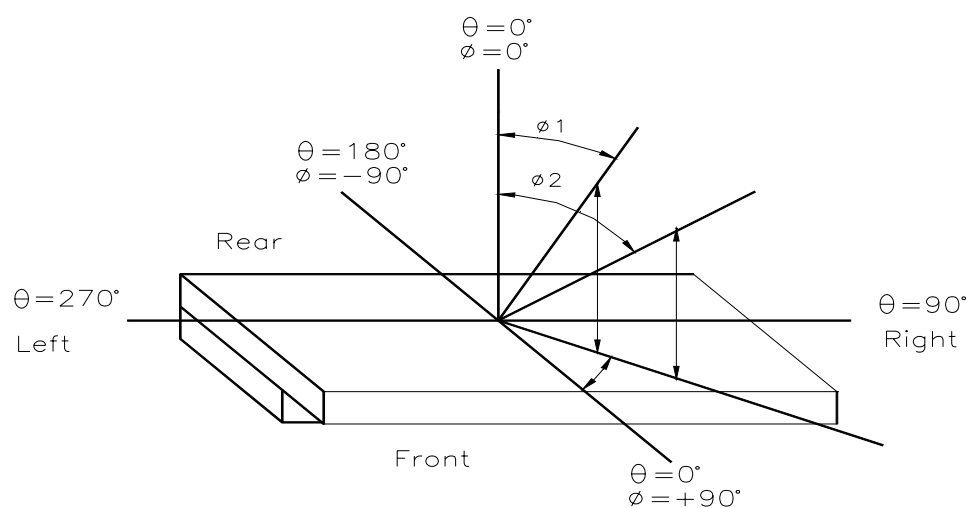

NOTE2: Definition of viewing Angle Range:  $\Delta \phi = |\phi 2 - \phi 1|$

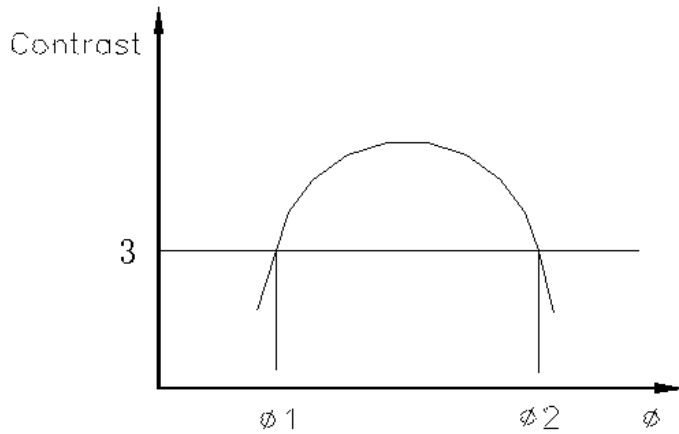

NOTE3: Definition of Contrast

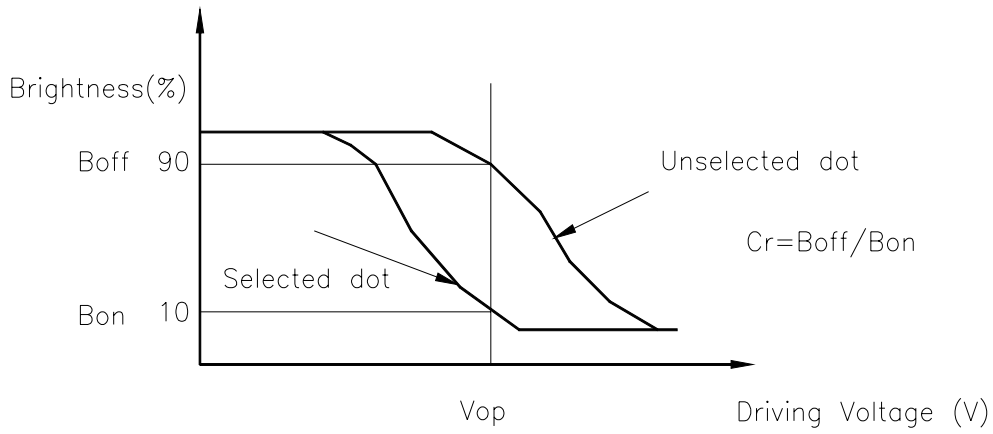

NOTE4: Definition of Response Time

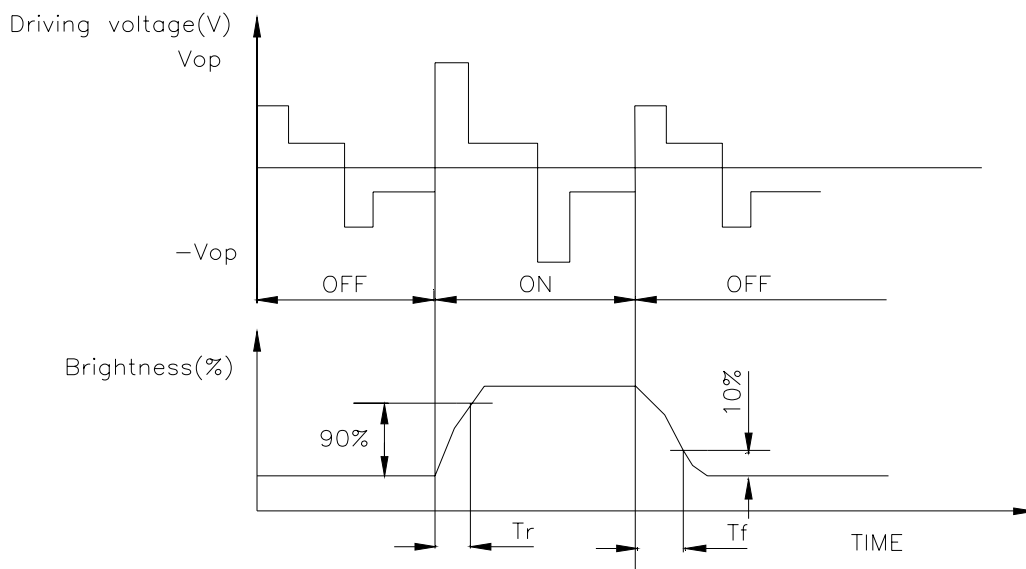

### 3-3. LED BACK-LIGHT SPECIFICATION

#### 3-3-1.ABSOLUTE MAXIMUM RATINGS(Ta=25 °C)

ITEM	SYMBOL	RATINGS	UNIT
PEAK FORWARD CURRENT	IF	200	mA
REVERSE VOLTAGE	VR	4	V
POWER DISSIPATION	Po	1.0	W
SOLDER TEMPERATURE: 3 SEC. AT 2mm FROM THE REFLECTOR EDGE		260	°C

#### 3-3-2. ELECTRICAL/OPTICAL SPECIFICATIONS:

ITEM	SYMBOL	STANDARD VALUE			UNIT	CONDITIONS
		MIN.	TYP.	MAX.		
FORWARD CURRENT	IF	40	52	70	mA	VF =5.0V Ta=25 °C
LUMINOUS INTENSITY	IV	200		-	cd/m2	
COLOR RANGE		WHITE X=0.26-0.32, Y=0.26-0.32				Luminous is not through the LCD
BRIGHTNESS UNIFORMITY	△%	75%				
REVERSE CURRENT	IR	-	-	0.2	mA	VR=4V

## 4. TIMING CHARACTERISTICS

### 4-1. INTERFACE TIMING CHART

ITEM	SYMBOL	CONDITION	MIN.	MAX.	UNIT
C/D SET UP TIME	$t_{CDS}$	$V_{DD}=5.0V$ $V_{SS}=0V$ $T_a=25^\circ C$	100		ns
C/D HOLD TIME	$t_{CDH}$		10		
C/D, RD, WR PULSE WIDTH	$t_{CE}, t_{RD}, t_{WR}$		80		
DATA SET UP TIME	$t_{DS}$		80		
DATA HOLD TIME	$t_{DH}$		40		
ACCESS TIME	$t_{ACC}$		-	150	
OUTPUT HOLD TIME	$t_{OH}$		10	50	

### 4-2 CPU READ/WRITE OPERATION SEQUENCE

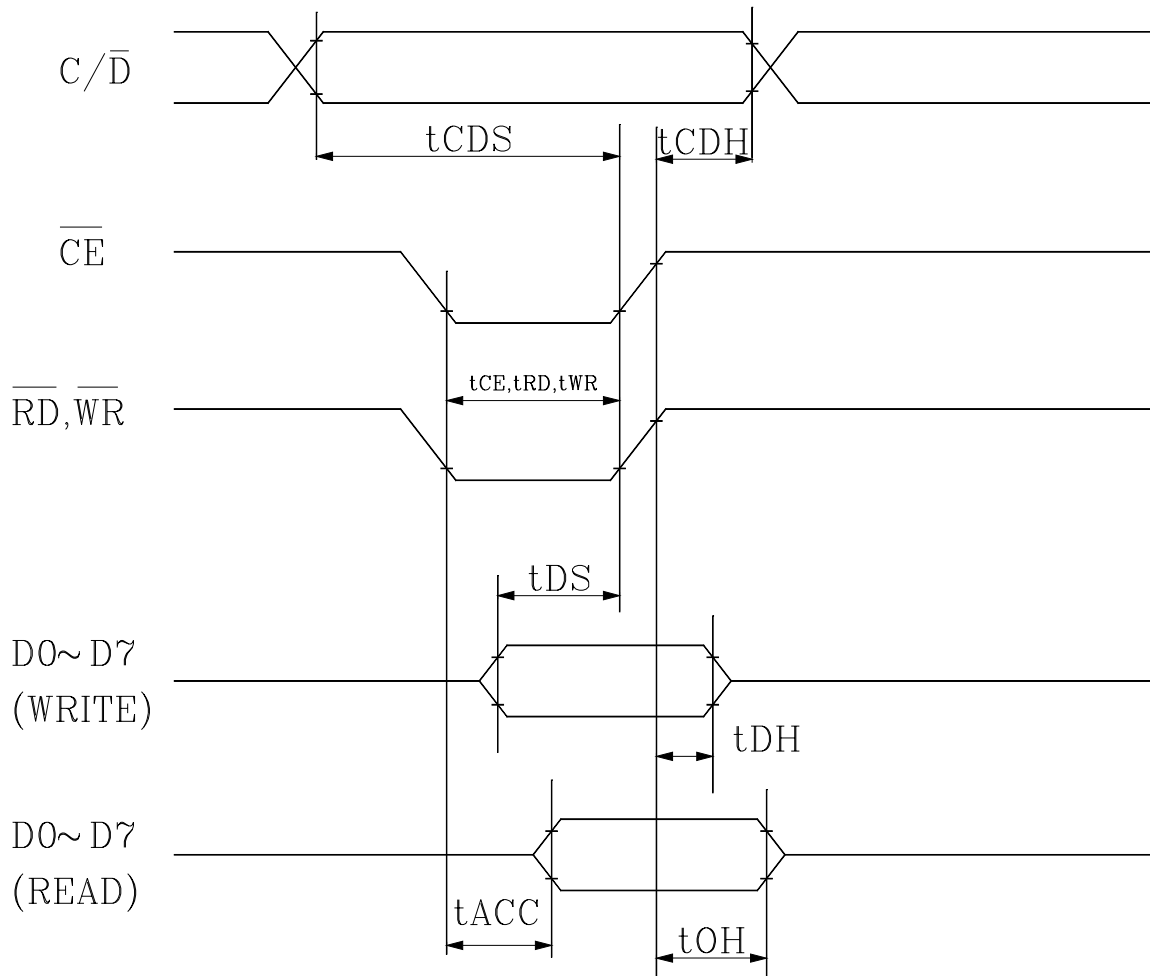



## 5. FUNCTION DESCRIPTION& INSTRUCTION SET

- In this module : It is work in single-scan, the RAM size is 8K, the address from 0000H-1FFFH. the PIN HALT already connected to VDD, MD2&MD3=H, Column=32.
- Alter power on, it is necessary to reset. RESET is kept L between 5 clocks up (oscillation clock).
- When HALT=L, the oscillation stops. The power supply for the LCD must now be turned off, to protect the LCD from DC bias.
- The HALT function includes the RESET function.
- The column /line counter and display register are cleared by RESET. (Other registers are not cleared.) Disable the display using the clear-display register.
- The status must be checked before data or commands are sent. The MSB=0 status check must be done in particular. There is a possibility of erroneous operation due to a hard interrupt.
- STA0 and STA1 must be checked at the same time. When a command is executed, data transmission errors may occur.
- The T6963C can only handle one byte per machine cycle (16 clocks). It is impossible to send more than two data in a machine cycle.
- When using a command with operand data, it important to send the data first, and then execute the command.
- The character codes used by the T6963C are different from ASCII codes.
- State after RESET/HALT

TERMIAL	HALT	RESET
D0 to D7	F	F
d0 to d7	F	F
r/w	H	H
ce	H (Note1)	H (Note1)
ad0 to ad15	H (Note2)	H (Note2)
ce0,ce1	H (Note1)	H (Note1)
ED,HOD	Final data	Final data
HSCP	L	L
LP	L	L
CDATA	H	H
FR	H	H
CH1	L	KO
CH2	L	VEND
DSPON	L	L
XO	H	OSC clock

H: level H

L: level L

F: Floating (high impedance)

K0: Test signal

VEND: Test signal

(Note 1): In Attribute mode, H or L according to state of graphic pointer

(Note 2): in Attribute mode, data of graphic pointer

## ● RAM Interface

The external RAM is used to store display data (text, graphic and external CG data).

With single-scan, text data, graphic data and external CG data can be freely allocated to the memory area ( 64KB max.)

With dual-scan, LCD I is allocated to 0000H to 7FFFH (32 KB max.), LCD II is allocated to 8000H to FFFFH (32 KB max.). Text data, graphic data and external CG data can be freely allocated in LCD I . In LCD II, the same address must be allocated as in LCD I , except ad15. ad15 determines selection of LCD I or LCD II .

It can be use the address decoded signals ce0( 0000 to 07FFFH),ce1(0800 to 0FFFFH) within 4 KB.ce0 and ce1 allow decoding of addresses in the ranges (0000 to 07FFFH) and (0800 to 0FFFFH) respectively within a 4-KB memory space.

(Example)

(1) Single-Scan

(2) Dual-scan

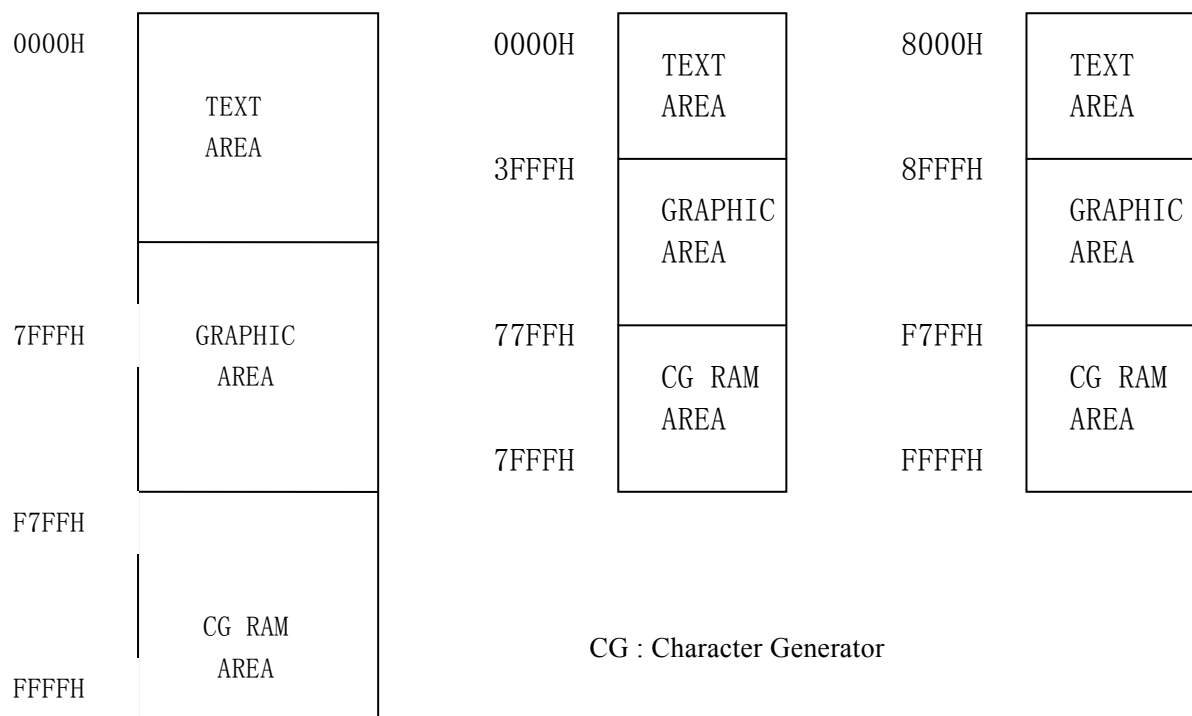

## ● Flowchart of communications with MPU

(1) Status Read

A status check must be performed before data is read or written.

Status check

The Status of T6963C can be read from the data lines.

RD	L
WR	H
CE	L
C/D	H

D0 to D7 Status word

The T6963C status word format is as follows:

MSB							LSB
STA7 D7	STA6 D6	STA5 D5	STA4 D4	STA3 D3	STA2 D2	STA1 D1	STA0 D0

STA0	Check command execution capability	0: Disable 1: Enable
STA1	Check data read/write capability	0: Disable 1: Enable
STA2	Check Auto mode data read capability	0: Disable 1: Enable
STA3	Check Auto mode data write capability	0: Disable 1: Enable
STA4	Not used	
STA5	Check controller operation capability	0: Disable 1: Enable
STA6	Error flag. Used for screen peek and screen copy commands.	0: Disable 1: Enable
STA7	Check the blink condition	0: Disable 1: Enable

(Note 1) it is necessary to check STA0 and STA1 at the same time.

There is a possibility of erroneous operation due to a hardware interrupt.

(Note 2) for most modes STA0/STA1 are used as a status check.

(Note 3) STA2 and STA3 are valid in Auto mode; STA0 and STA1 are invalid.

Status checking flow

a)

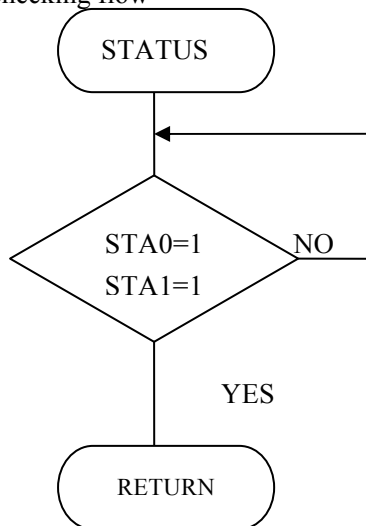

b)

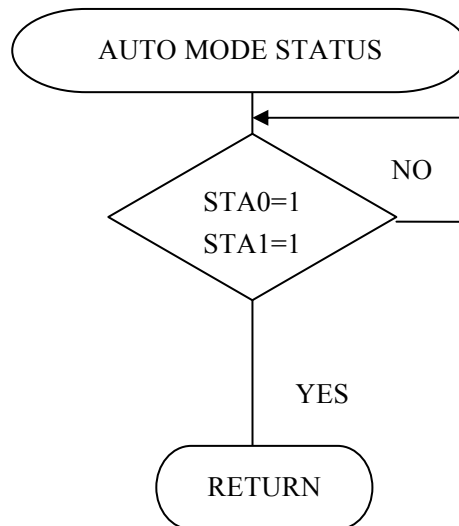

\*1  
STA2=1 (Read)  
or  
STA3=1 (Write)

(Note 4) When using the MSB=0 command, a status read must be performed.

If a status check is not carried out, the T6963C can not operate normally, even after a delay time.

The hardware interrupt occurs during the address calculation period (at the end of each line).

If a MSB=0 command is sent to the T6963C during this period, the T6963C enters wait status.

If a status check is not carried out in this state before the next command is sent, There is the possibility that the command or data will not be received.

---

(2) Setting data

When using the T6963C, first set the data, then set the command.

Procedure for sending a command

a) the case of 1 data

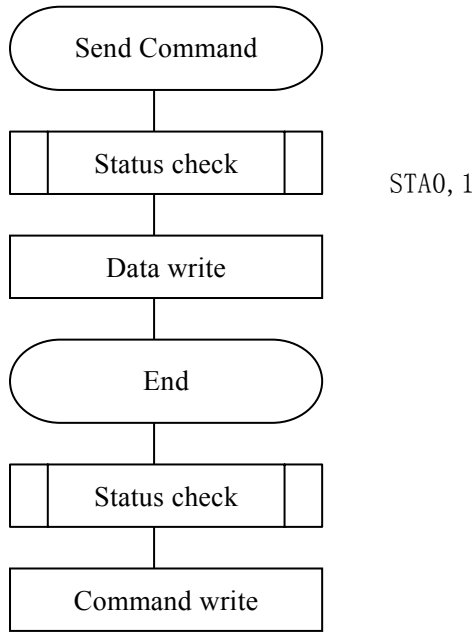

b) the case of 2 data

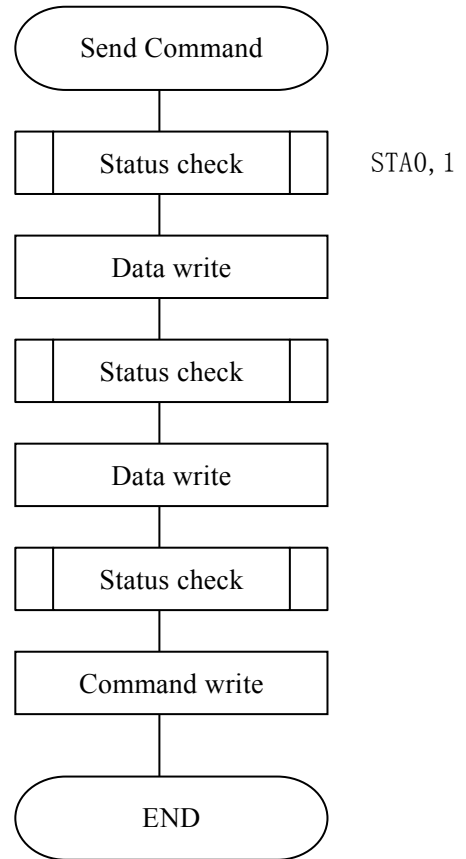

(Note) When sending more than two data, the last datum (or last two data) is valid.

## ● COMMAND DEFINITIONS

COMMAND	CODE	D1	D2	FUNCTION
REGIDTERS SETTING	00100001	X address	Y address	Set Cursor Pointer
	00100010	Data	00H	Set Offset Register
	00100100	Low address	High address	Set Address Pointer
SET CONTROL WORD	01000000	Low address	High address	Set Text Home Address
	01000001	Columns	00H	Set Text Area
	01000010	Low address	High address	Set Graphic Home Address
	01000011	Columns	00H	Set Graphic Area
MODE SET	1000x000	—	—	OR mode
	1000x001	—	—	EXOR mode
	1000x011	—	—	AND mode
	1000x100	—	—	Text Attribute mode
	10000xxx	—	—	Internal CG ROM mode
	10001xxx	—	—	External CG RAM mode
DISPLAY MODE	10010000	—	—	Display off
	1001xx10	—	—	Cursor on, blink off
	1001xx11	—	—	Cursor on, blink on
	100101xx	—	—	Text on, graphic off
	100110xx	—	—	Text off, graphic on
	100111xx	—	—	Text on, graphic on
CURSOR PATTERN SELECT	10100000	—	—	1-line cursor
	10100001	—	—	2-line cursor
	10100010	—	—	3-line cursor
	10100011	—	—	4-line cursor
	10100100	—	—	5-line cursor
	10100101	—	—	6-line cursor
	10100110	—	—	7-line cursor
	10100111	—	—	8-line cursor
DATA AUTO READ/WRITE	10110000	—	—	Set Data Auto Write
	10110001	—	—	Set Data Auto Read
	10110010	—	—	Auto Reset
DATA READ/WRITE	11000000	Data	—	Data Write and Increment ADP
	11000001	—	—	Data Read and Increment ADP
	11000010	Data	—	Data Write and Decrement ADP
	11000011	—	—	Data Read and Decrement ADP
	11000100	Data	—	Data Write and Nonvariable ADP
	11000101	—	—	Data Read and Nonvariable ADP
SCREEN PEEK	1110000	—	—	Screen Peek
SCREEN COPY	11101000			Screen Copy
BIT SET/RESET	11110xxx	—	—	Bit Reset
	11111xxx	—	—	Bit Set
	1111x000	—	—	Bit 0 (LSB)
	1111x001	—	—	Bit 1
	1111x010	—	—	Bit 2
	1111x011	—	—	Bit 3
	1111x100	—	—	Bit 4
	1111x101	—	—	Bit 5
	1111x110	—	—	Bit 6
	1111x111	—	—	Bit 7 (MSB)

## ● Setting registers

CODE	HEX.	FUNCTION	D1	D2
00100001	21H	SET CURSOR POINTER	X ADRS	Y ADRS
00100010	22H	SET OFFSET REGISTER	DATA	00H
00100100	24H	SET ADDRESS POINTER	LOW ADRS	HIGH ADRS

### (1) Set Cursor Pointer

The position of the cursor is specified by X ADRS and Y ADRS. The cursor position can only be moved by this command. Data read/write from the MPU never change the cursor pointer. X ADRS and Y ADRS are specified as follows.

ADRS and Y ADRS are specified as follows.

X ADRS 00H to 4FH (lower 7 bits are valid)

Y ADRS 00H to 1FH (lower 5 bits are valid)

a) Single-Scan

Y ADRS 00H to 0FH

b) Dual-Scan

Y ARDS 00H to 0FH  
Upper screen

Y ADRS 10H to 1FH  
Lower screen

### (2) Set Offset Register

the offset register is used to determine the external character generator RAM area.

The T6963C has a 16-bit address bus as follows.

MSB			LSB
	ad15~ad11	ad10~ad3	ad2~ad0
	Offset Register Data	Character Code	Line Scan

T6963C assign External character generator, when character code set 80H to FFH in using internal character generator. Character code 00H to 80H assign External character generator, when External generator mode.

The senior five bits define the start address in external memory of the CG RAM area. The next eight bits represent the character code of the character. In internal CG ROM mode, character codes 00H to 7FH represent the predefined “internal” CG RAM mode, character codes 80H to FFH represent the user’s own “external” characters. In external CG RAM mode, all 256 codes from 00H to FFH can be used to represent the user’s own character. The three least significant bits indicate one of the eight rows of eight dots that define the character’s shape.



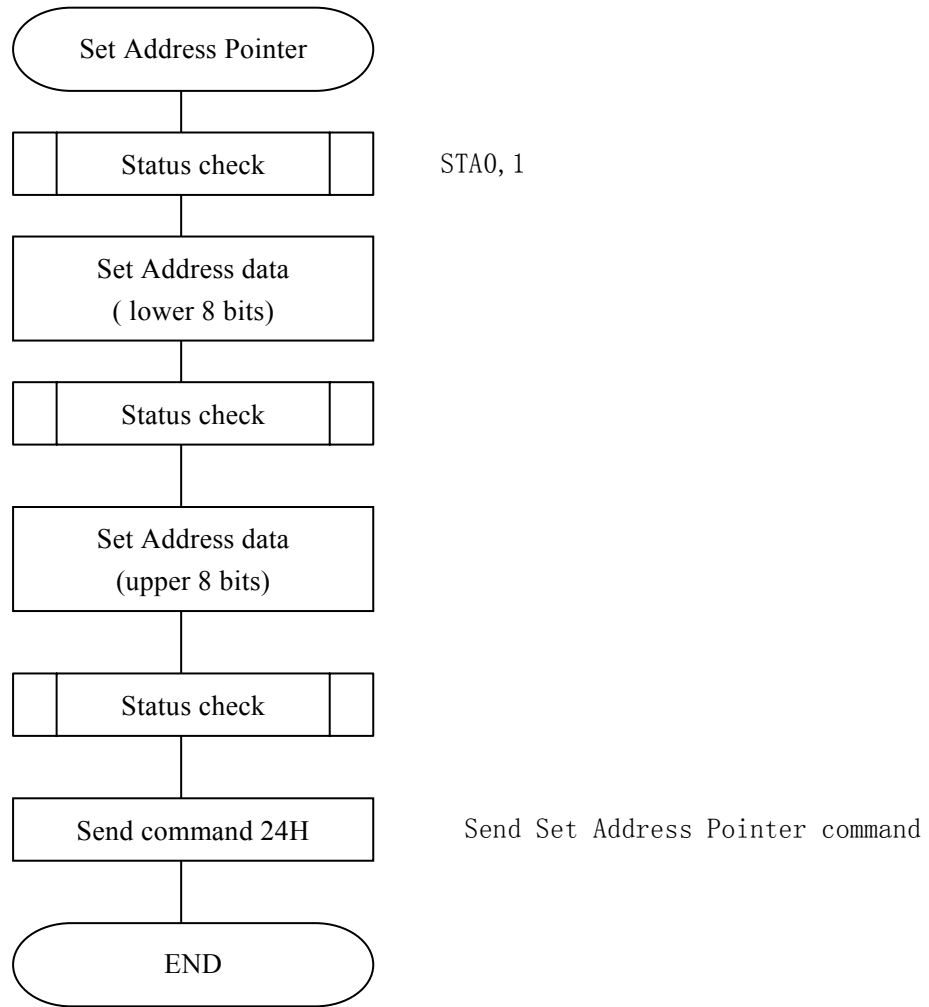

## ● Set Control Word

CODE	HEX.	FUNCTION	D1	D2
01000000	40H	Set Text Home Address	Low address	High address
01000001	41H	Set Text Area	Columns	00H
01000010	42H	Set Graphic Home Address	Low address	High address
01000011	43H	Set Graphic Area	Columns	00H

The home address and column size are defined by this command.

### (1) Set Text Home Address

The starting address in the external display RAM for text display is defined by this command.

The text home address indicates the leftmost and uppermost position.

TH		TH+CL
TH+TA		TH+TA+CL
(TH+TA)+TA		TH+2TA+CL
(TH+2TA)+TA		TH+3TA+CL



TH+(n-1)TA		TH+(n-1)TA+CL
------------	--	---------------

The relationship between external display RAM address and display position.

TH: Text home address

TA: Text area number (columns)

CL: Columns are fixed by hardware (pin-programmable)

Example)

Text home address : 0000H

Text area : 0020H

MD2=H,MD3=H : 32 columns

DUAL=H, MDS=L,MD0=L,MD1=H : 4 lines

0000H	0001H		001EH	001FH
0020H	0021H		003EH	003FH
0040H	0041H		005EH	005FH
0060H	0061H		007EH	007FH

## (2) Set Graphic Home Address

The starting address of the external display RAM used for graphic display is defined by this command. The graphic home address indicates the leftmost and uppermost position.

The relationship between external display RAM address and display position

GH		GH+CL
GH+GA		GH+GA+CL
(GH+GA)+GA		GH+2GA+CL
(GH+2GA)+GA		GH+3GA+CL
GH+(n-1)GA		GH+(n-1)GA+CL

GH: Graphic home address

GA: Graphic area number (columns)

CL: Columns are fixed by hardware (pin-programmable)

Example)

Graphic home address : 0000H

Graphic area : 0020H

MD2=H,MD3=H : 32 columns

DUAL=H, MDS=L,MD0=H,MD1=H : 2 lines

0000H	0001H		001EH	001FH
0020H	0021H		003EH	003FH
0040H	0041H		005EH	005FH
0060H	0061H		007EH	007FH
0080H	0081H		009EH	009FH
00A0H	00A1H		00BEH	00BFH
00C0H	00C1H		00DEH	00DFH
00E0H	00E1H		00FEH	00FFH
0100H	0101H		011EH	011FH
0120H	0121H		013EH	013FH
0140H	0141H		015EH	015FH
0160H	0161H		017EH	017FH

0180H	0181H		019EH	019FH
01A0H	01A1H		01BEH	01BFH
01C0H	01C1H		01DEH	01DFH
01E0H	01E1H		01FEH	01FFH

(3) Set Text Area

The display columns are defined by the hardware setting. This command can be to adjust the column of the display.

(Example)

LCD size : 20 columns, 4 line  
 Text home address : 0000H  
 Text area : 0014H  
 MD2=H,MD3=H : 32 columns  
 DUAL=H, MDS=L,MD0=L,MD1=H : 4 lines

0000	0001	-----	0013	0014	-----	001F
0014	0015	-----	0027	0028	-----	0033
0028	0029	-----	003B	003C	-----	0047
003C	003D	-----	004F	0050	-----	005B

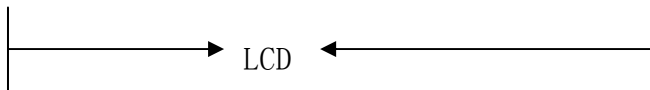

(4) Set Graphic Area

The display columns are defined by the hardware setting. This command can be used to adjust the columns of the graphic display.

(Example)

LCD size : 20 columns, 2 line  
 Graphic home address : 0000H  
 Graphic area : 0014H  
 MD2=H,MD3=H : 32 columns  
 DUAL=H, MDS=L,MD0=H,MD1=H : 2 lines

0000	0001	-----	0013	0014	-----	001F
0014	0015	-----	0027	0028	-----	0033
0028	0029	-----	003B	003C	-----	0047
003C	003D		004F	0050		005B
0050	0051		0063	0064		006F
0064	0065		0077	0078		0083
0078	0079		008B	008C		0097
008C	008D		009F	00A0		00AB
00A0	00A1		00B3	00B4		00BF
00B4	00B5		00C7	00C8		00D3
00C8	00C9		00DB	00DC		00E7
00DC	00DD		00EF	00F0		00FD
00F0	00F1		0103	0104		011F
0104	0105		0127	0128		0123
0128	0129		013B	013C		0147
013C	013D		014F	0150		015B

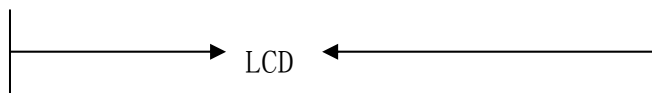

If the graphic area setting is set to match the desired number of columns on the LCD, the addressing scheme will be automatically modified so that the start address of each line equals the end address of the previous line +1.

### ● Mode set

CODE	FUNCTION	OPERAND
1000X00	OR Mode	—
1000X01	EXOR Mode	—
1000X011	AND Mode	—
1000X100	TEXT ATTRIBUTE Mode	—
10000XXX	Internal Character Generator Mode	—
10001XXX	External Character Generator Mode	—

X: invalid

The display mode is defined by this command. The display mode does not change until the next command is sent. The logical OR, EXOR, AND of text or graphic display can be displayed.

In Internal Character Generator mode, character codes 00H to 7FH are assigned to the built-in character generator ROM. The character codes 80H to FFH are automatically assigned to the external character generator RAM.

(Example)

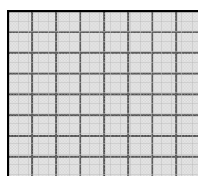

GRAPHIC

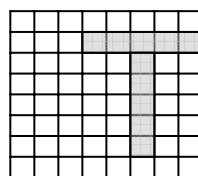

TEXT

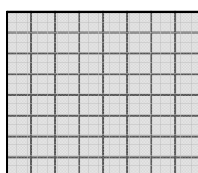

“OR”

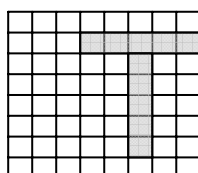

“AND”

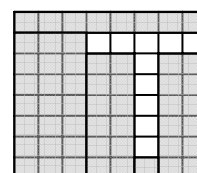

“EXOR”

(Note) Attribute functions can only be applied to text display, since the attribute data is placed in the graphic RAM area.

Attribute functions

The attribute operations are Reverse display, Character blink and Inhibit. The attribute data is written into the graphic area which was defined by the Set Control Word command. Only text display is possible in Attribute Function mode; graphic display is automatically disabled. However, the Display Mode command must be used to turn both Text and Graphic on in order for the Attribute function to be available.

The attribute data for each character in the text area is written to the same address in the graphic area. The Attribute function is defined as follows.

Attribute RAM 1byte

X	X	X	X	d3	d2	d1	d0
---	---	---	---	----	----	----	----

d3	d2	d1	d0	FUNCTION
0	0	0	0	Normal display
0	1	0	1	Reverse display
0	0	1	1	Inhibit display
1	0	0	0	Blink of normal display
1	1	0	1	Blink of reverse display
1	0	1	1	Blink of inhibit display

X: invalid

## ● Display mode

CODE	FUNCTION	COERAND
10010000	Display off	—
1001xx10	Cursor on, blink off	—
1001xx11	Cursor on, blink on	—
100101xx	Text on, graphic off	—
100110xx	Text off, graphic on	—
100111xx	Text on, Graphic on	—

X: invalid

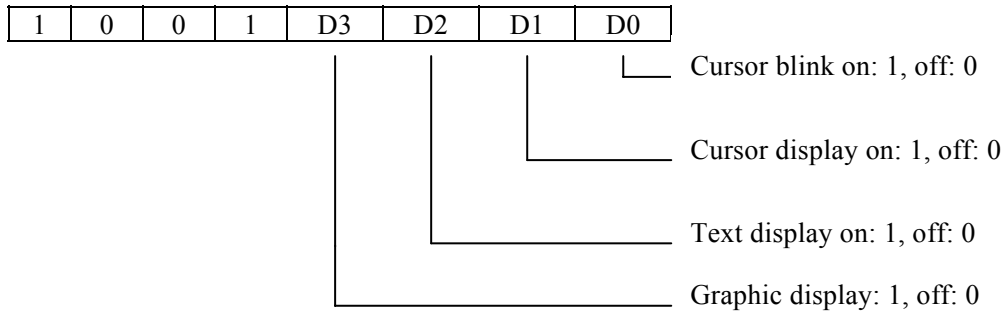

(Note) It is necessary to turn on “Text display” and “Graphic display” in the following cases.

- a) Combination of text/graphic display
- b) Attribute function

### ● Cursor Pattern Select

CODE	FUNCTION	OPERAND
10100000	1-line cursor	—
10100001	2-line cursor	—
10100010	3-line cursor	—
10100011	4-line cursor	—
10100100	5-line cursor	—
10100101	6-line cursor	—
10100110	7-line cursor	—
10100111	8-line cursor	—

When cursor display is ON, this command selects the cursor pattern in the range 1 line to 8 lines. The cursor address is defined by the Cursor Pointer Set command.

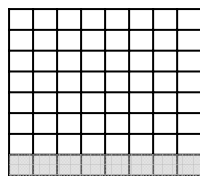

1-line cursor

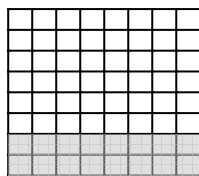

2-line cursor

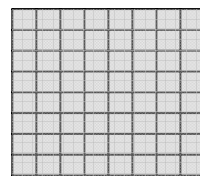

8-line cursor

### ● Data Auto Read/Write

CODE	HEX.	FUNCTION	OPERAND
10110000	B0H	Set Data Auto Write	—
10110001	B1H	Set Data Auto Read	—
10110010	B2H	Auto Reset	—

This command is convenient for sending a full screen of data from the external display RAM. After setting Auto mode, a Data Write (or Read) command is need not be sent between each datum. A Data Auto Write (or Read) command must be sent after a Set Address Pointer command. After this

command, the address pointer is automatically incremented by 1 after each datum. In Auto mode, the T6963C cannot accept any other commands.

The Auto Reset command must be sent to the T6963C after all data has been sent, to clear Auto mode.

(Note) A Status check for Auto mode

(STA2,STA3 should be checked between sending of each datum. Auto Reset should be performed after checking STA3=1 (STA2=1). Refer to the following flowchart.

a) Auto Read mode

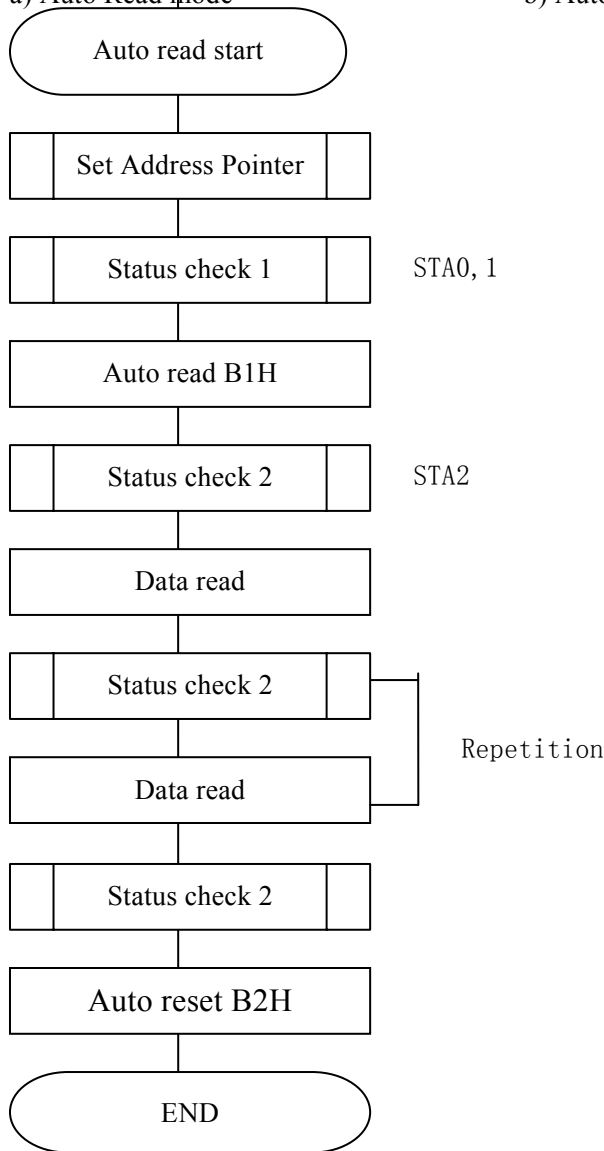

b) Auto Write mode

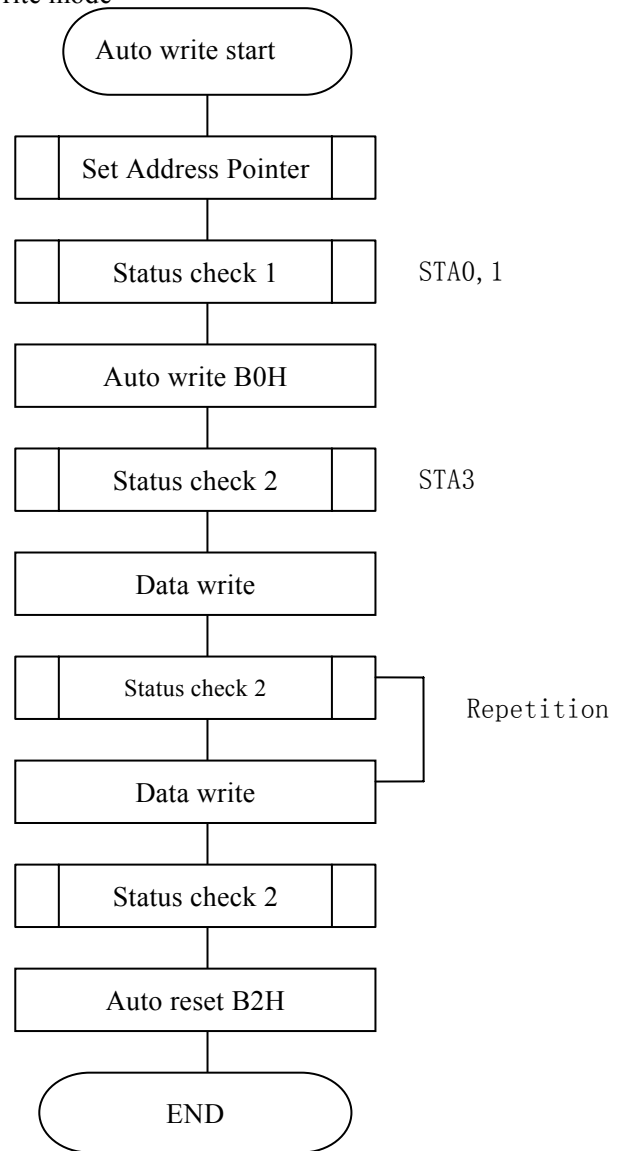

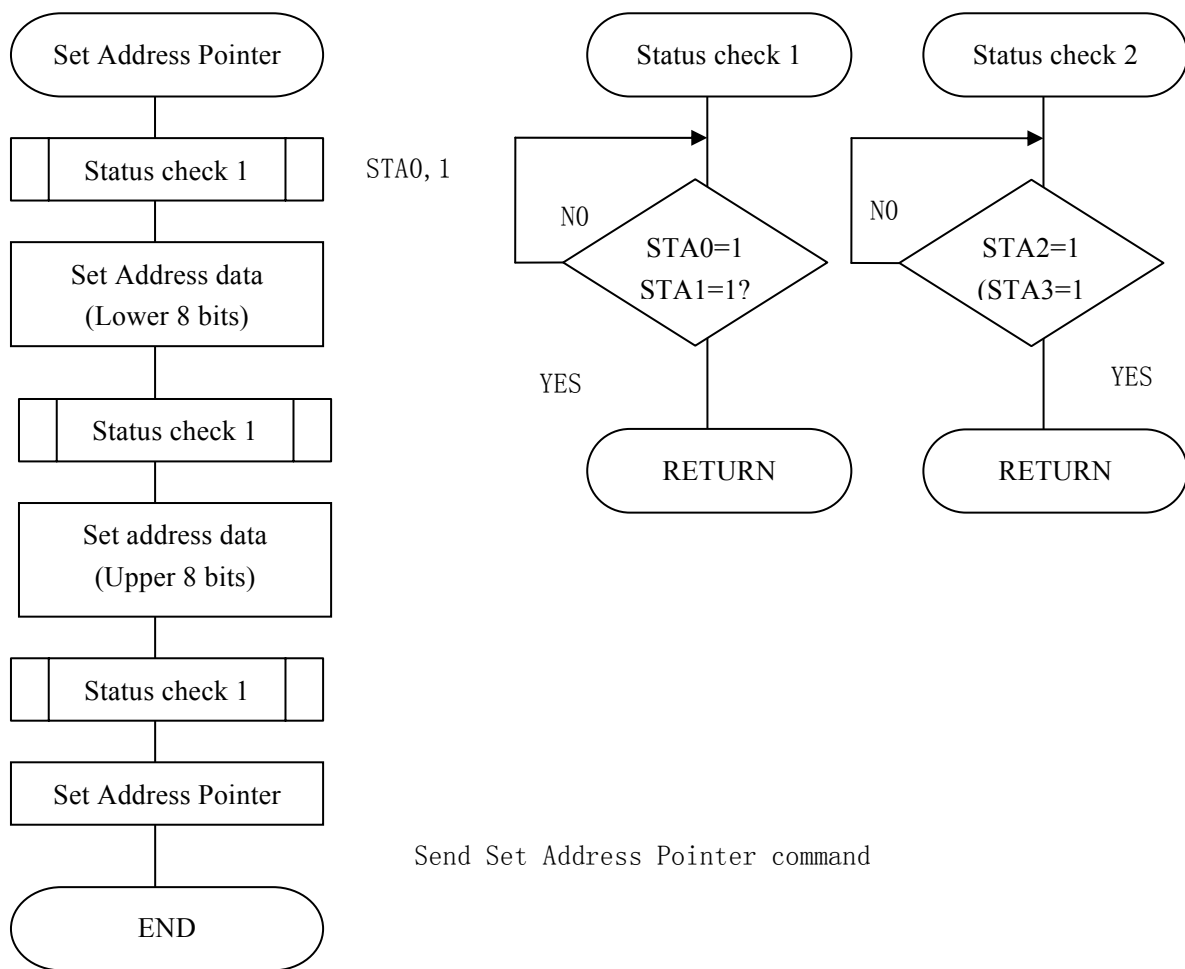

● Data Read/Write

CODE	HEX.	FUNCTION	OPERAND
11000000	C0H	Data Write and Increase ADP	Data
11000001	C1H	Data Read and Increase ADP	—
11000010	C2H	Data Write and Decrease ADP	Data
11000011	C3H	Data Read and Decrease ADP	—
11000100	C4H	Data Write and Nonvariable ADP	Data
11000101	C5H	Data Read and Nonvariable ADP	—

This command is used to for writing data from the MPU to external display RAM, and reading data from external display RAM to the MPU. Data Write/Data Read should be executed after setting address using Set Address Pointer command. The address pointer can be automatically incremented or decremented using this command.

(Note) This command is necessary for each 1-byte datum.

Refer to the following flowchart.

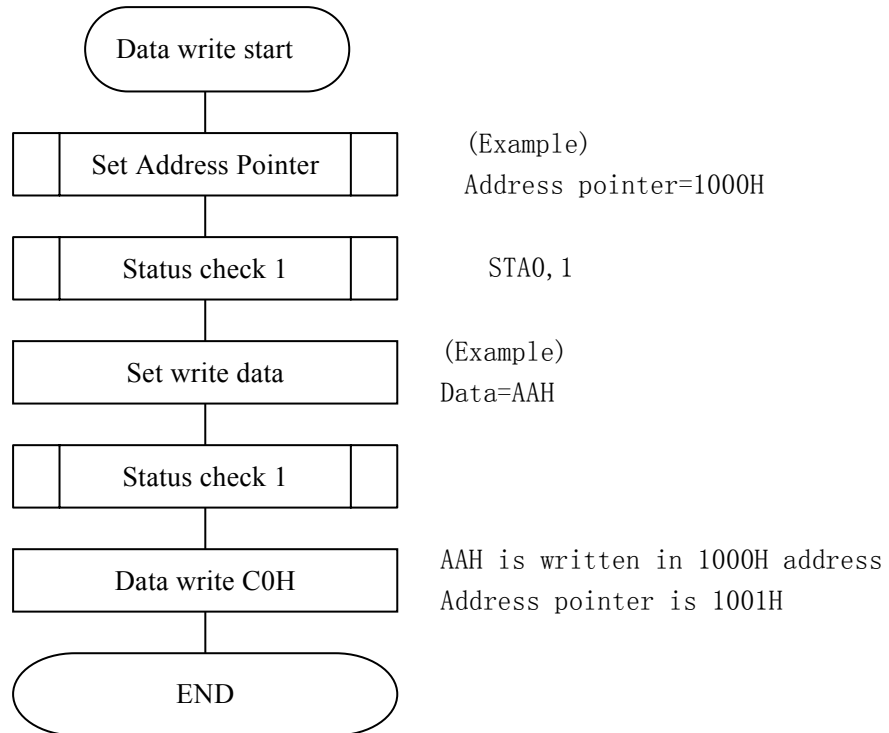

## ● Screen Peek

CODE	HEX.	FUNCTION	OPERAND
11100000	E0H	Screen Peek	—

This command is used to transfer 1 byte of display data to the data stack; this byte can then be read from the MPU by data access. The logical combination of text and graphic display data on the LCD screen can be read by this command.

The status (STA6) should be checked just after Screen Peek command. If the address determined by the Set Address Pointer command is not in the graphic area, this command is ignored and a status flag (STA6) is set

Refer to the following flowchart.



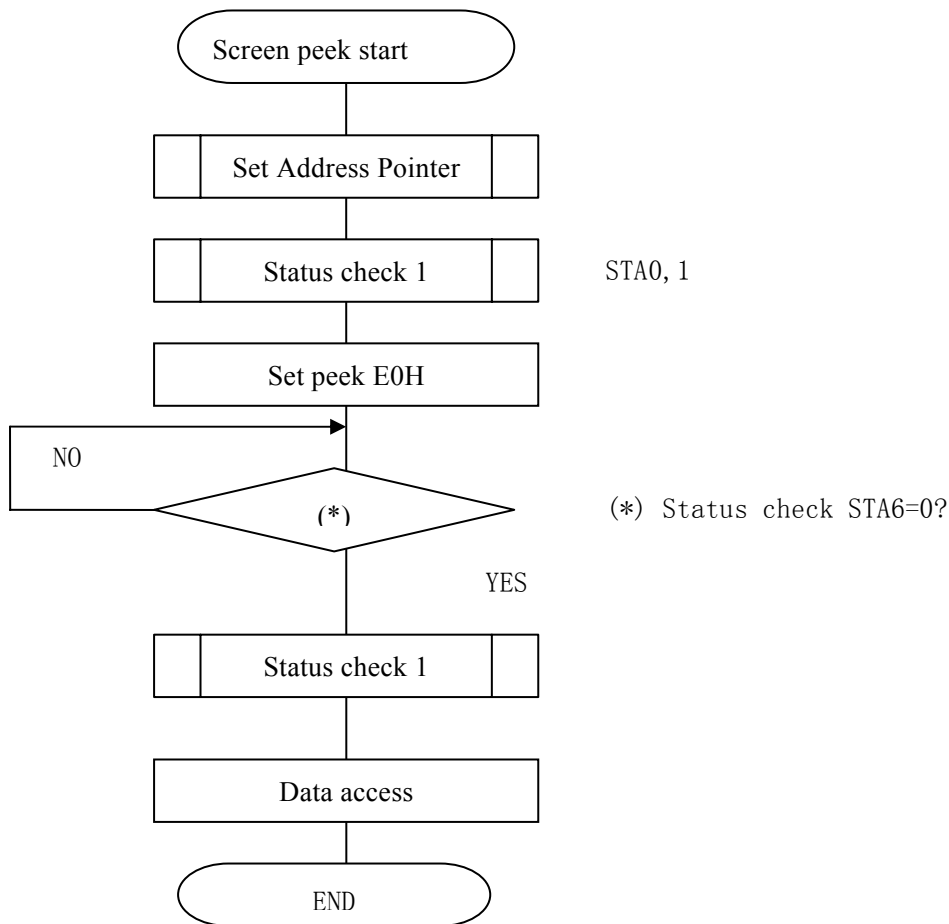

(Note) This command is available when hardware column number and software column number are the same. Hardware column number is related to MD2 and MD3 setting. Software column number is related to Set Text Area and Set Graphic Area command.

### ● Screen copy

CODE	HEX.	FUNCTION	OPERAND
11101000	E8H	Screen Copy	—

This command copies a single raster line of data to the graphic area.

The start point must be set using the set address pointer command.

(Note 1) If the attribute function is being used, this command is not available.

(With Attribute data is graphic area data.)

(Note 2) With Dual-scan, this command cannot be used (because the T6963C cannot separate the upper screen data lower screen data).

Refer to the following flowchart.

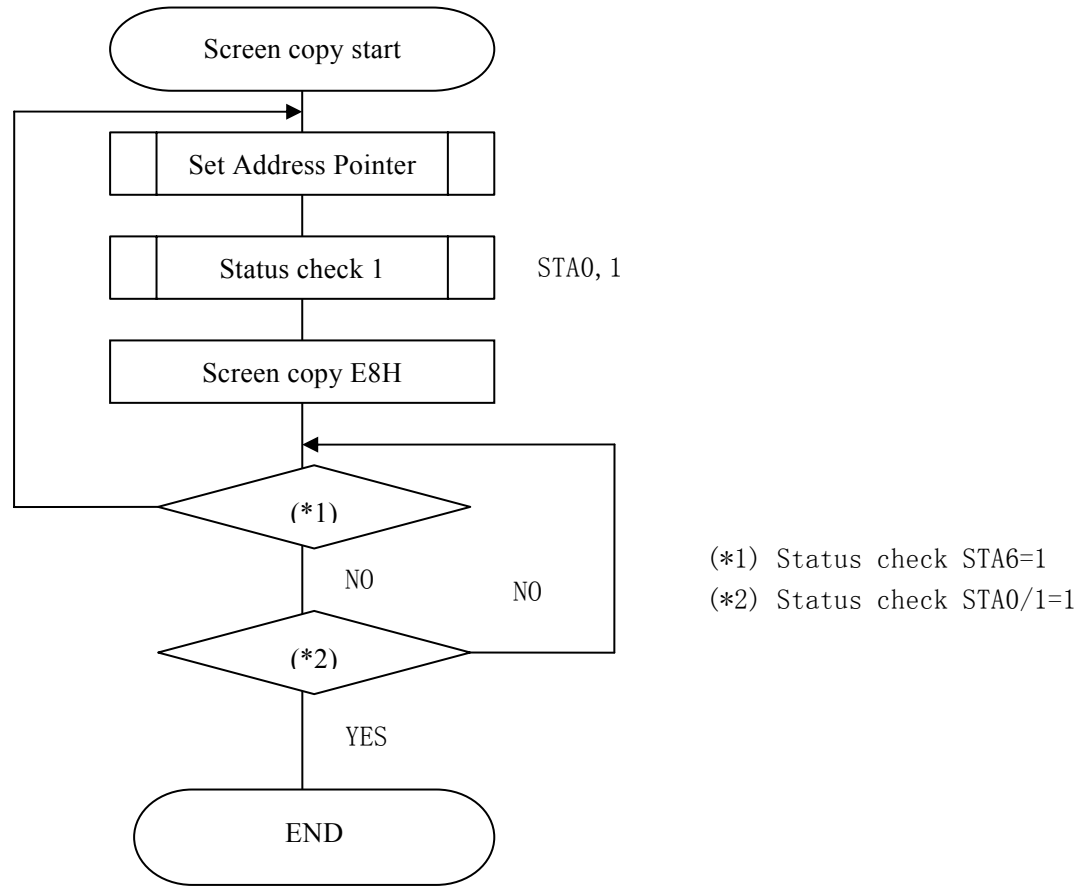

(Note) This command is available when hardware column number and software column number are the same. Hardware column number is related to MD2 and MD3 setting. Software column number to Set Text Area and Set Graphic Area command.

● Bit set/reset

CODE	FUNCTION	OPERAND
11110xxx	Bit Reset	—
11111xxx	Bit Set	—
1111x001	Bit 0 (LSB)	—
1111x001	Bit 1	—
1111x010	Bit 2	—
1111x011	Bit 3	—
1111x100	Bit 4	—
1111x101	Bit 5	—
1111x110	Bit 6	—
1111x111	Bit 7 (MSB)	—

X: invalid

---

This command use to set or reset a bit of the byte specified by the address pointer.  
Only one bit can be set/reset at a time.  
Refer to the following flowchart.

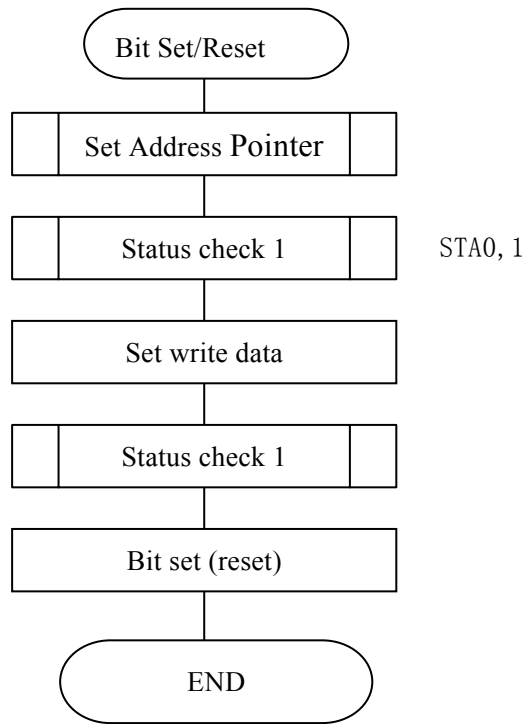

## 6. CHARACTER FONT TABLE

[ CORRESPONDENCE BETWEEN CHARACTER CODE AND CHARACTER PATTERN]

**CHARACTER CODE MAP**  
ROM code 0101

LSB MSB	0	1	2	3	4	5	6	7	8	9	A	B	C	D	E	F
0		!	"	#	\$	%	&	'	(	)	*	+	,	-	.	/
1	0	1	2	3	4	5	6	7	8	9	:	;	<	=	>	?
2	@	A	B	C	D	E	F	G	H	I	J	K	L	M	N	O
3	P	Q	R	S	T	U	V	W	X	Y	Z	[	\	]	^	_
4	`	a	b	c	d	e	f	g	h	i	j	k	l	m	n	o
5	p	q	r	s	t	u	v	w	x	y	z	{		}	~	
6	5	6	7	8	9	A	B	C	D	E	F	G	H	I	J	K
7	L	M	N	O	P	Q	R	S	T	U	V	W	X	Y	Z	



---

## 8.QUALITY SPECIFICATION

### 8-1.ACCEPTABLE QUALITY LEVEL

Inspection items	Sampling procedures	AQL
Visual-operating (Electro-optical)	GB2828.1-2003 Inspection level II Normal inspection Single sample inspection	0.65
Visual-not operating	GB2828.1-2003 Inspection level II Normal inspection Single sample inspection	1.5
Dimension measurement	GB2828.1-2003 Inspection level II Normal inspection Single sample inspection	1.5

### 8-2. INSPECTION CONDITIONS

#### 8-2-1. THE ENVIRONMENTAL

-Room temperature:  $25 \pm 3$  °C

-Humidity:  $65 \pm 20\%$ RH

### 8-3. INSPECTION STANDARDS

#### 8-3-1. VISUAL WHILE OPERATING

Items to be inspected	Inspection standard
. No display	. If any pattern is not active at all, they can be rejected.
. Irregular operating	. No irregular operating are allowed . Appeared different display, which they should be chosen in the pattern, or appeared in different position where they should be chosen.
.Irregular display	. Any segment doesn't active, they can be rejected.
. Over current	. The total current required to activate the module should not be exceed the MAX current in specification.
.View angles	. Valves that don't meet the minimum value noted in the specification. they can be rejected.
.Contrast	. Valves that don't meet the minimum value noted in the specification, they can be reject.
.LCD operate voltage	. Meet the specification.

### 8-3-2. Visual while not operating

Module dimension	. Meet the module outline drawing, not exceed the tolerance.
LCD panel scratch	.Following scratches inside the effective viewing area considered as the defects when their width & length are larger than the following combinations. Number: one or more Width: 0.1 length: 3.0 three or more Width: 0.05 length: 2.0 three or more Width: 0.03 length: 3.0 When the defects exceed this, it can be rejected.

## 9.RELIABILITY

### Standard Specification for Reliability of General-purpose LCM

Test Item	Test Condition	Note
High Temperature Store	80 °C,12hr.	2
Low Temperature Store	-30 °C,4hr	2
Humidity Store	40 °C,90%RH,96hr	1,2
High Temperature Operation	70°C,typical operating conditions,48hr	
Low Temperature Operation	-20°C,typical operating conditions,48hr	
Shock	Acceleration: 100m/s <sup>2</sup> , Pulse time: 11ms, 6 times in each direction of XYZ	
Mechanical Vibration	10~55Hz sweep, 3G, ampl.=0.75mm(max) XYZ for 20 min, each.	

Note 1: Condensation of water is not permitted on the module.

Note 2: The module should be inspected after 4 hour storage in normal conditions (15~35 °C,45~65%RH)

## 10. HANDLING PRECAUTION

### 10-1. MOUNTING METHOD

The panel of the LCD module consists of two thin glass plates with polarizes which easily get damaged since the module is fixed by utilizing fitting holes in the printed circuit board. Extreme care should be taken when handling the LCD modules.

### 10-2. CAUTION OF LCD HANDLING & CLEANING

When cleaning the display surface. Use soft cloth with solvent (recommended below) and wipe lightly.

- Isopropyl alcohol
- Ethyl alcohol
- Tri chlorotri fluoroethane

Do not wipe the display surface with dry or hard materials that will damage the polarizes surface.

Do not use the following solvent:

- Water

- 
- Ketone
  - Aromatics

### 10-3.CAUTION AGAINST STATIC CHARGE

The LCD modules use COMS LSI drivers. So we recommend that you connect any unused input terminal to Vdd or Vss, do not input any signals before power is turned on and ground your body. work/assembly table. And assembly equipment to protect against static electricity.

### 10-4.PACKAGING

-Modules use LCD elements, and must be treated as such avoid intense shock and falls from a height

-To prevent modules from degradation, do not operate or store them exposed directly to sunshine or high temperature/humidity.

### 10-5.CAUTION FOR OPERATION

-It is indispensable to drive LCM within the specified voltage limit since the higher voltage than the limit shortens LCM life.

-Response time will be extremely delayed at lower temperature than the operating temperature range and on the other hand at higher temperature LCD show dark color in them.

However those phenomena do not mean malfunction or out of order with LCD, which will come back in the specified operating temperature range.

-If the display area is pushed hard during operation. Some font will be abnormally displayed but it resumes normal condition after turning off once.

-A slight dew depositing on terminals is a cause for Electro-chemical reaction resulting in terminal open circuit.

Under the maximum operating temperature, 50%RH or less is required

### 10-6 STORAGE

In the case of storing for a long period of time (for instance, for years) for the purpose or replacement use. the following ways are recommended

-Storage in a polyethylene bag with the opening sealed so as not to enter fresh air outside in it, and with no desiccant.

-Placing in a dark place where neither exposure to direct sunlight nor light is, keeping temperature in the specified storage temperature range.

-Storing with no touch on polarizes surface by the anythingelse.  
(it is recommended to store them as they have been contained in the inner container at the time of delivery from us.

### 10-7.SAFETY

-It is recommendable to crash damaged or unnecessary LCD into pieces and wash off liquid crystal by using solvents such as acetone and ethanol, which should be burned up later.



---

-When any liquid crystal leaked out of a damaged glass cell comes in contact with your hands, please wash it off well with soap and water.

## 11.PRECAUTION FOR USE

11-1.A limit sample should be provided by the both parties on an occasion when the both parties agree its necessity.

Judgement by a limit sample shall take effect after the limit sample has been established and confirmed by the both parties.

11-2.On the following occasions, the handling of problem should be decided through discussion and agreement between representative of the both parties

-When a question is arisen in this specification.

-When a new problem is arisen which is not specified in this specifications.

-When an inspection specification change or operating condition change in customer is reported to GEM-TECH, and some problem is arisen in this specification due to the change.

-When a new problem is arisen at the customer's operating set for sample evaluation in the customer size.

## 12. REVISIONS HISTORY

REVISION	DATE	DESCRIPTION
1.0	2012-12-5	First release