



**冀诚电子**  
GEM-TECH ELECTRONICS

## LCD MODULE SPECIFICATIONS

Customer:
Customer Part No.:
Gem-tech Model Name: GTG-160324-BTCL2C
Release Date: 2013-9-29
Customer Approval:
Date:
The above signature represents that the product specifications, testing regulation, and warranty in the specifications are accepted.

**HEBEI GEM-TECH ELECTRONICS CO., LTD.**

No.368 North Xinshi Road, FL.8 Chuangxin BLD P.C.: 050091

Tel.: +86 311 8381 5999, 8381 6999 Fax.: +86 311 8383 1999

<http://www.gemtech-hb.com>

**Confidential**

This information contained herein is the exclusive property of Gem-tech and shall not be distributed, reproduced, or disclosed in whole or in part without prior written permission of Gem-tech. Subject to change without notice.

---

# Contents

1. BASIC SPECIFICATION
2. ABSOLUTE MAXIMUM RATINGS
3. ELECTRICAL & OPTICAL CHARACTERISTICS
4. TIMING CHARACTERISTICS
5. FUNCTION DESCRIPTION& INSTRUCTION SET
6. INSTRUCTION CODE
7. DISPLAY DATA RAM ADDRESS MAP
8. DIMENSIONAL OUTLINE
9. QUALITY SPECIFICATION
10. RELIABILITY
11. HANDLING PRECAUTION
12. PRECAUTION FOR USE
13. REVISIONS HISTORY

# 1. BASIC SPECIFICATION

## 1.1 DISPLAY SPECIFICATIONS .

- . DISPLAY MODE : STN BLUE TRANSMISSIVE NEGATIVE
- . COLOR : DISPLAY DOT: WHITE  
DISPLAY BACKGROUNDND: BLUE
- . DISPLAY FORMAT : 160X32 DOTS
- . INPUT DATA : 8-BITS PARALLEL DATA INPUT FROM A MPU
- . MULTIPLEXING : 1/32 DUTY
- . VIEWING DIRECTION : 12 O'CLOCK
- . DRIVED IC : SBN0080G\_S02 (OR EQV)
- . BEZEL : 0.6T

## 1.2 MECHANICAL SPECIFICATION

ITEM	SPECIFICATIONS	UNIT	REMARK
DIMENSIONAL OUTLINE	116.0(W)×44.0(H)×14.5MAX.(T)	mm	*REFERENCE DIMENSIONAL OUTLINE
VIEW AREA	99.0(W)×24.0(H)		
EFFECTIVE V/AREA	94.36(W)×18.84(H)	mm	
NUMBER OF DOTS	160DOTS×32DOTS	--	
DOT PITCH	0.59(W)×0.59(H)	mm	
DOT SIZE	0.55(W)×0.55(H)	mm	

## 1.3 BLOCK DIAGRAM

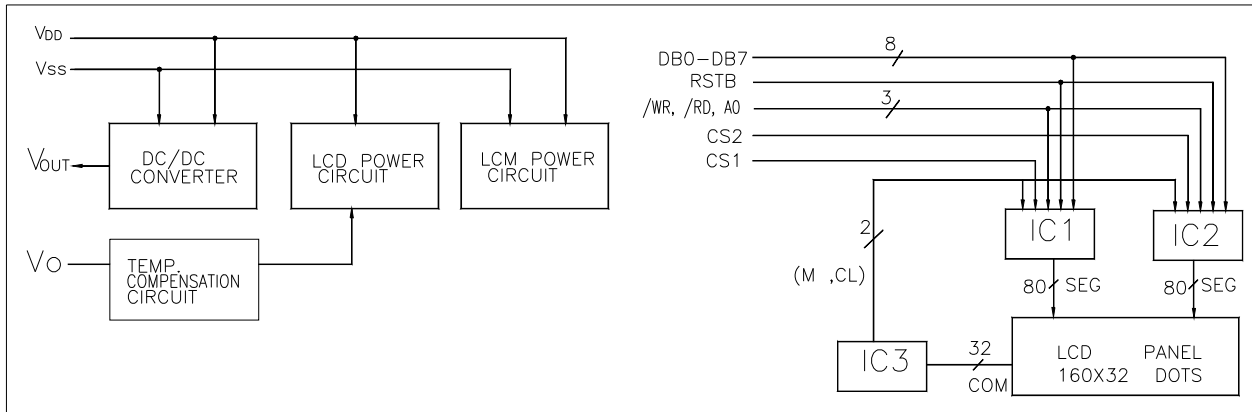

#### 1.4 TERMINAL FUNCTIONS

PIN NO.	SYMBOL	LEVEL	FUNCTION
1	A0	H/L	H: Display data L: Instruction code
2	/CS2	L	Chip selection for IC2
3	/CS1	L	Chip selection for IC1
4	/RD	L	Data/status read
5	/WR	L	Data/instruction write
6	V <sub>DD</sub>	5.0V	Power supply
7	V <sub>SS</sub>	0V	Power supply(GND)
8-15	DB0-DB7	H/L	Data bus line
16	RST	H	Reset signal
17	V <sub>o</sub>	-	Contrast adjust
18	V <sub>EE</sub>	-	Negative voltage output
19	A		Power supply for LED B/L(+)
20	K		Power supply for LED B/L(-)

#### 1.5 POWER SUPPLY CIRCUIT AND CONTRAST ADJUST

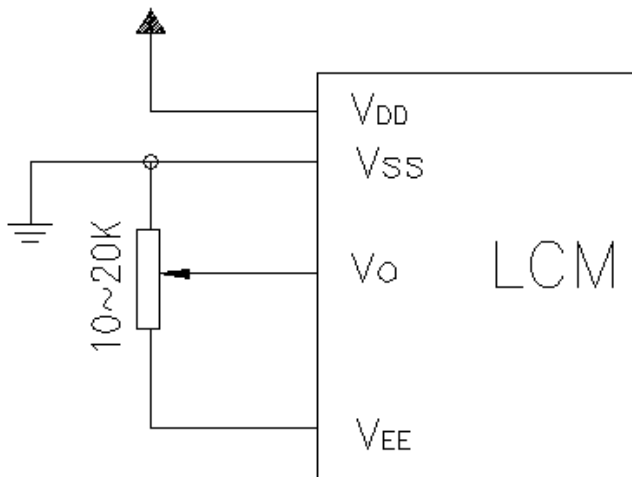

Recommended voltage:  $V_{DD}-V_o = 7.5V$

#### 2. ABSOLUTE MAXIMUM RATINGS ( $T_a=25^{\circ}C$ , $V_{SS}=0V$ )

PARAMETER	SYMBOL	RATINGS	UNITS
Power Supply Voltage For Logic	V <sub>DD</sub>	-0.3~7.0	V
Power Supply Voltage For LCD	V <sub>DD</sub> -V <sub>EE</sub>	0~13.5	V
Input Voltage	V <sub>IN</sub>	0~V <sub>DD</sub>	V
Operating Temperature	T <sub>opr</sub>	-20~+70	°C
Storage Temperature	T <sub>stg</sub>	-30~+80	°C

### 3. ELECTRICAL CHARACTERISTICS

#### 3.1 ELECTRICAL CHARACTERISTICS (Ta=25°C)

ITEM	SYMBOL	CONDITION	MIN	TYPE	MAX.	UNIT	NOTE
LOGIC CIRCUIT POWER SUPPLY VOLTAGE	V <sub>DD-VSS</sub>	————	4.5	5.0	5.25	V	
INPUT VOLTAGE	V <sub>IH</sub>	————	0.7V <sub>DD</sub>	—	V <sub>DD</sub>	V	
INPUT VOLTAGE	V <sub>IL</sub>	————	GND	—	0.3V <sub>DD</sub>	V	
LOGIC CIRCUIT POWER SUPPLY CURRENT	I <sub>DD</sub>	V <sub>DD-VSS</sub> =5.0	————	3.0	10.0	mA	
RECOMMENDED LCD DRIVING VOLTAGE	V <sub>OP</sub> φ=0 θ=0	Ta=25 °C	6.6	6.9	7.2	V	

#### 3.2 ELECTRO—OPTICAL CHARACTERISTICS (Ta=25 °C V<sub>DD</sub>=5.0±0.25V)

ITEM	SYMBOL	CONDITION	MIN	TYPE	MAX	UNIT	NOTE
VIEW ANGLE	φ2-φ1	K≥3	—	40	—	DEG	NOTE1,NOTE2
CONTRAST	K	φ=0° ,θ=0°	3	5	—	—	NOTE3
FRAME FREQUENCY				128		Hz	
RESPONSE TIME	Tr(rise)	φ=0° ,θ=0°	—	250	350	ms	
	Tf(fall)	φ=0° ,θ=0°	—	250	350	ms	NOTE4

NOTE1: Definition of Viewing Angle θ, φ

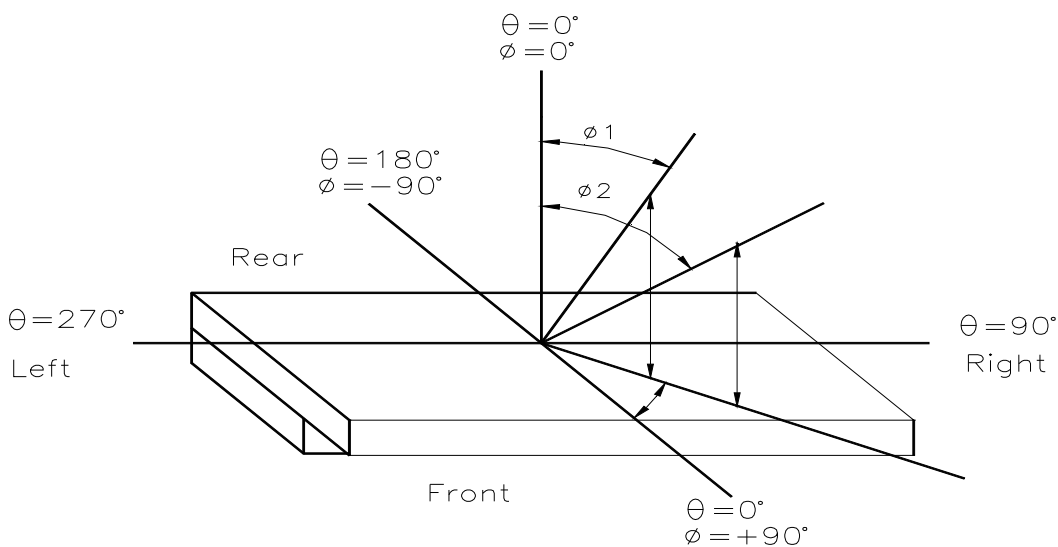

NOTE2: Definition of viewing Angle Range:  $\Delta\phi = |\phi_2 - \phi_1|$

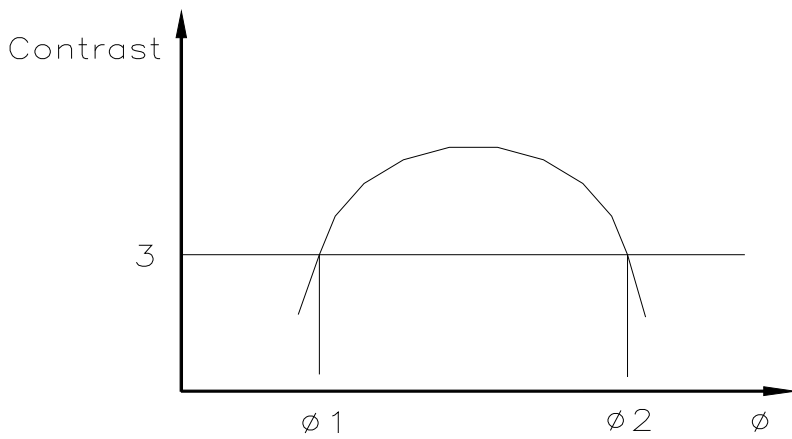

NOTE3: Definition of Contrast

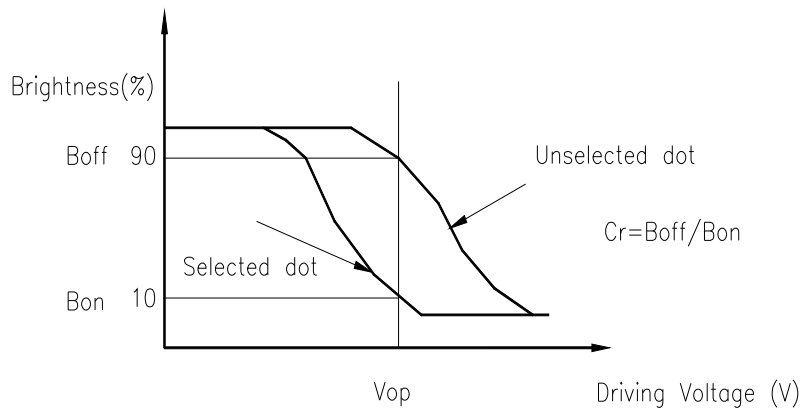

NOTE4: Definition of Response Time

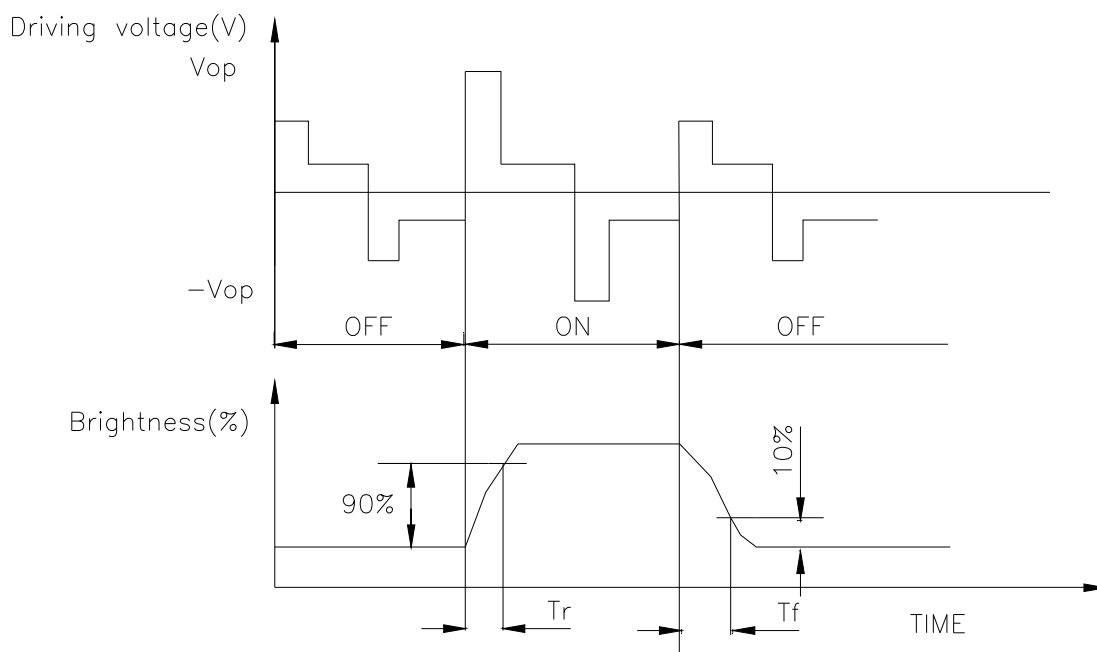

3-3. LED BACK-LIGHT SPECIFICATION

3-3-1.ABSOLUTE MAXIMUM RATINGS(Ta=25 °C)

ITEM	SYMBOL	RATINGS	UNIT
PEAK FORWARD CURRENT	IF	40	mA
REVERSE VOLTAGE	VR	4	V
POWER DISSIPATION	Po	--	W
SOLDER TEMPERATURE: 3 SEC. AT 2mm FROM THE REFLECTOR EDGE		260	°C

3-3-2. ELECTRICAL/OPTICAL SPECIFICATIONS:

ITEM	SYMBOL	STANDARD VALUE			UNIT	CONDITIONS
		MIN.	TYP.	MAX.		
FORWARD CURRENT	IF		26	32	mA	VF =5.0V Ta=25 °C
LUMINOUS INTENSITY	IV	200		-	cd/m2	
COLOR		WHITE				Luminous is not through the LCD
RANGE		X=0. 26-0. 32, Y=0. 26-0. 32				
BRIGHTNESS UNIFORMITY	△%	75%				
REVERSE CURRENT	IR	-	-	0.2	mA	VR=4V

## 4. BUS TIMING CHARACTERISTICS

### 4-1. INTERFACE TIMING CHART

ITEM	SYMBOL	CONDITION	MIN.	MAX.	UNIT
C/D SET UP TIME	$t_{CDS}$	$V_{DD}=5.0V$ $V_{SS}=0V$ $T_a=25^\circ C$	35		ns
C/D HOLD TIME	$t_{CDH}$		10		
RD, WR PULSE WIDTH	$t_{RD}, t_{WR}$		200		
DATA SET UP TIME	$t_{DS}$		80		
DATA HOLD TIME	$t_{DH}$		10		
ACCESS TIME	$t_{ACC}$		-	90	
OUTPUT HOLD TIME	$t_{OH}$		10	60	

### 4-2 CPU READ/WRITE OPERATION SEQUENCE

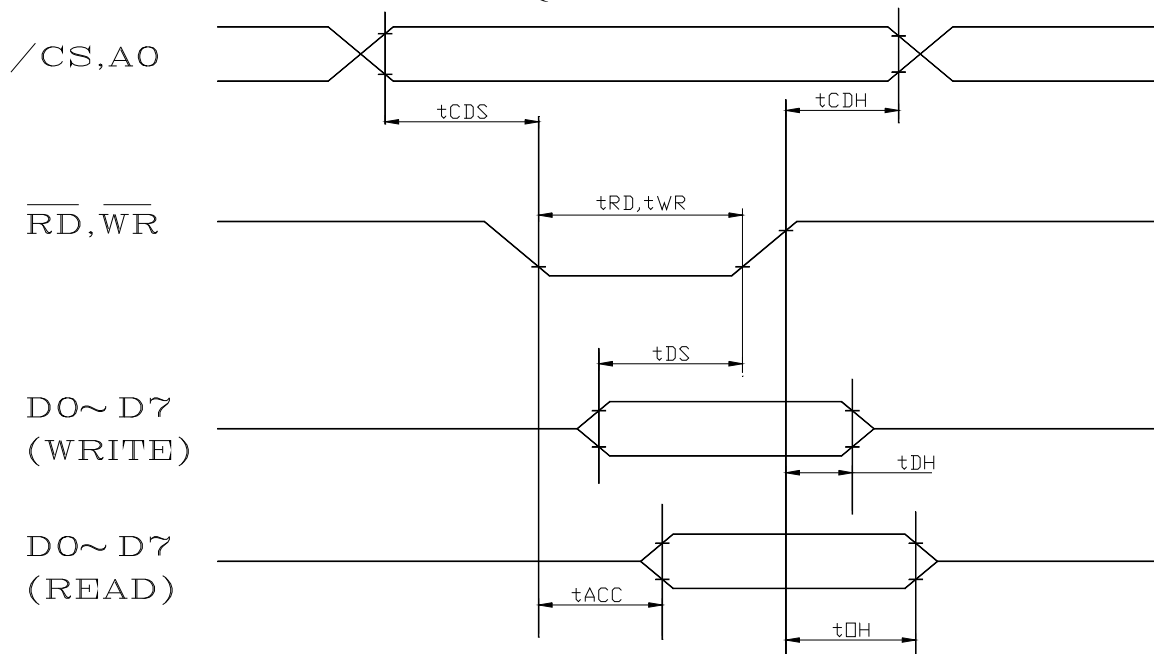



---

## 5. FUNCTION DESCRIPTION& INSTRUCTION SET

### 5.1 Data transfer

The SED1521 use the A0, /RD and /WR signals to transfer data between the system and MPU and internal register. The combinations used are given in the table below.

To read the contents of display data RAM, twice access of read instruction is needed. In first access, data in display data RAM is latched into output register. In second access, MPU can read data which is latched. That is, to read the data in display data RAM, it needs dummy read. But status read does not need dummy read.

A0	/RD	/ER	Function
0	1	0	Instruction Input
	0	1	Status read ( busy check )
1	1	0	Data write ( from input register to display data RAM)
	0	1	Data read ( from display data RAM to output register)

### 5.2 Reset

System reset can be initialized by setting RSTB terminal at low level when turning power on, receiving instruction from MPU. When RSTB becomes low, following procedure is occurred.

1. Display off
2. Display start line register become set by 0. (Z-address 0)

While RSTB is low level, no instruction except status read can be accepted. Reset status appears at DB4. After DB4 is low, any instruction can be accepted.

The Conditions of power supply at initial power up are shown in table 1.

### 5.3 Busy Flag

Busy flag indicates that SED1521 is operating or not operating. When busy flag is high, NJU6450 is in internal operating. When busy flag is low, SED1521 can accept the data or instruction.

DB7 indicates busy flag of the SED1521.

### 5.4 Display On/Off Flip-Flop

The display on/off flip-flop makes on/off the liquid crystal display. When flip-flop is reset (logical low), selective voltage or non selective voltage appears on segment output terminals. When flip-flop is set (logical high), non selective voltage appears on segment output terminals regardless of display RAM data.

The display on/off flip-flop can change status by instruction. The display data at all segments disappear while RSTB is low. The status of the flip-flop is output to DB5 by status read instruction.

### 5.5 X Page Register

X page register designates page of the internal display data RAM. It has not count function. An address is set by instruction.

### 5.6 Y Address Counter

Y address counter designates address of the internal display data RAM. An address is set by instruction and is increased by 1 automatically by read or write operations of display data.

### 5.7 Display Data RAM

Display data RAM stores a display data for liquid crystal display. To express on state of dot matrix of liquid crystal display, write data 1. The other way, off state write 0.

## 5.8 Display Start Line Register

The display start line register indicates address of display data RAM to display top line of liquid crystal display. Bit data (DB<0:5>) of the display start line set instruction is latched in display start line register. It is used for scrolling of the liquid crystal display screen.

## 5.9 Initialization

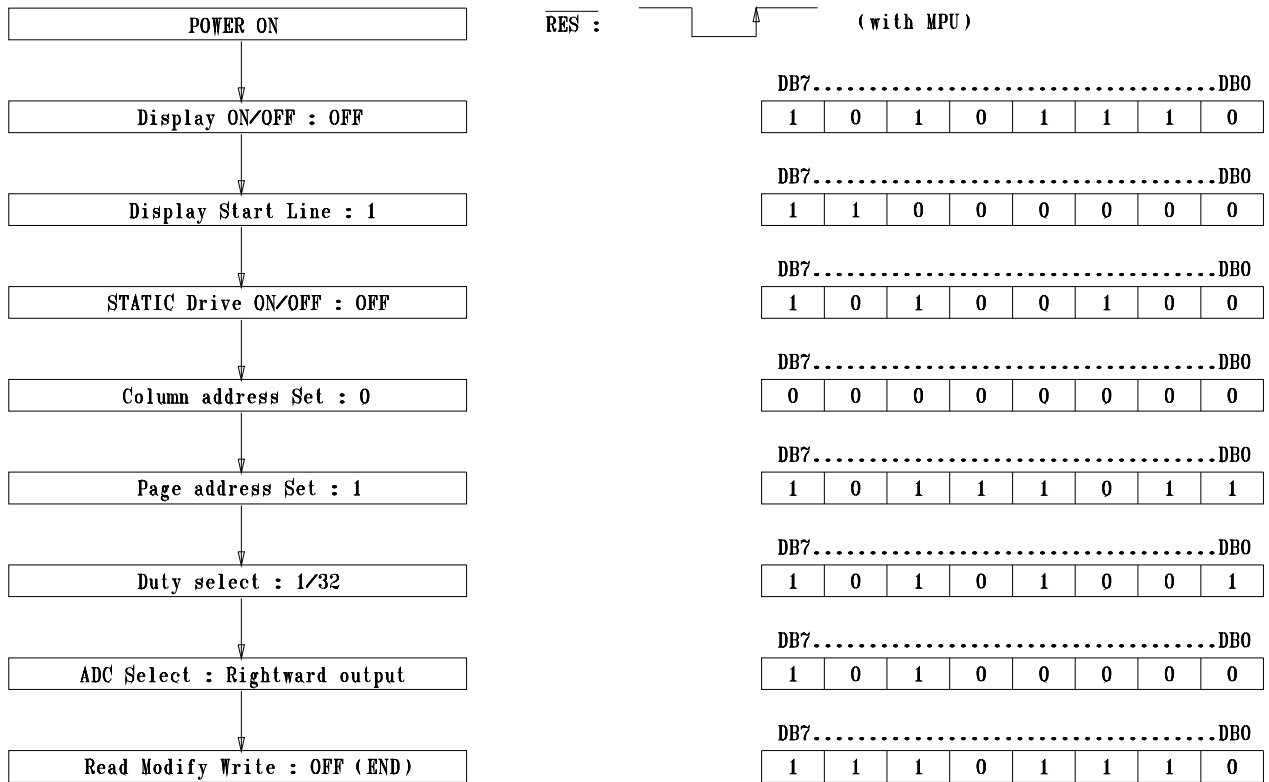

## 6. INSTRUCTION CODE

Instruction	C O D E											Description	
	A0	E	R/W	D7	D6	D5	D4	D3	D2	D1	D0		
Display on/off	0	1	0	1	0	1	0	1	1	1	0/1	Whole Display On/Off. 1: On, 0: Off(power save mode if the static Drive On)	
Display Start Line	0	1	0	1	1	0	Display Start Address ( 1—31 )				Determine the Display Line correspond to the COM0.		
Page Address	0	1	0	1	0	1	1	1	0	Page ( 0-3)		Set the Page of Disp.Data RAM to the Page Register.	
Column Address Set	0	1	0	0	Column Address ( 0—79 )						Set the Column Address of Display Data RAM.		
Status Read	0	0	1	B U S Y	A D C	ON / OFF	R E S E T	0	0	0	0	Read the status. BUSY 1: Working 0: Ready ADC 1: Clockwise Output 0: Counterclockwise ON/OFF 1: Disp Off 0: Disp On RESET 1: Reset 0: Normal	
Write Display Data	1	1	0	Write Data								Write the data to the Display Data RAM .	Access the predetermined address of the Display Data RAM.
Read Display Data	1	0	1	Read Data								Read the data from the Display Data RAM.	The Column Address increment “1” after read or write.
ADC Select	0	1	0	1	0	1	0	0	0	0	0/1	Used to reverse the correspondence between the Display RAM’s column addresses and segment driver output ports 0: Rightward (forward) output 1: Leftward (reverse) output	
Static Drive On/Off	0	1	0	1	0	1	0	0	1	0	0/1	Select the Dynamic or Static Driving. 1: Static Driving ( power saving ) 0: Dynamic Driving	
Duty Ratio Select	0	1	0	1	0	1	0	1	0	0	0/1	Select the duty ratio. 1: 1/32 Duty 0: 1/16 Duty	
Read Modify Write	0	1	0	1	1	1	0	0	0	0	0	Increment the Column address register when writing but no-change when reading.	
END	0	1	0	1	1	1	0	1	1	1	0	Release from the Read Modify Write Mode.	
Reset	0	1	0	1	1	1	0	0	0	1	0	Set the Display Start Line Register to 1st line , Column Address Counter to “0” and Page Address Register to “3”.	

## 7 DISPLAY DATA RAM ADDRESS MAP

PAGE ADDRESS	DISPLAY DATA	1ST DRIVER						2ND DRIVER				LINE ADDRESS	COMMON	
0,0	D0												00	COM0
	D1												01	COM1
	D2												02	COM2
	D3												03	COM3
	D4												04	COM4
	D5												05	COM5
	D6												06	COM6
	D7												07	COM7
0,1	D0												08	COM8
	D1												09	COM9
	D2												0A	COM10
	D3												0B	COM11
	D4												0C	COM12
	D5												0D	COM13
	D6												0E	COM14
	D7												0F	COM15
1,0	D0												10	COM16
	D1												11	COM17
	D2												12	COM18
	D3												13	COM19
	D4												14	COM20
	D5												15	COM21
	D6												16	COM22
	D7												17	COM23
1,1	D0												18	COM24
	D1												19	COM25
	D2												1A	COM26
	D3												1B	COM27
	D4												1C	COM28
	D5												1D	COM29
	D6												1E	COM30
	D7												1F	COM31
	COLUMN ADDRESS	00	01	02	03	---	4B	00	01	02	---	4B		
	SEGMENT	SEG0	SEG1	SEG2	SEG03	---	SEG79	SEG81	SEG82	SEG83	---	SEG159		

# 8. DIMENSIONAL OUTLINE

CUSTOMER'S APPROVAL  
SIGN:  
DATE:

- NOTE:  
 1. STN-BLUE-NEGATIVE-TRANSMISSIVE  
 2. OP. TEMP.: -20°C TO 70°C  
 3. ST. TEMP.: -30°C TO 80°C  
 4. VIEWING DIR: 12:00  
 5. V<sub>CD</sub>=6.9V  
 6. BACKLIGHT: WHITE, V<sub>LED</sub>=5.0V

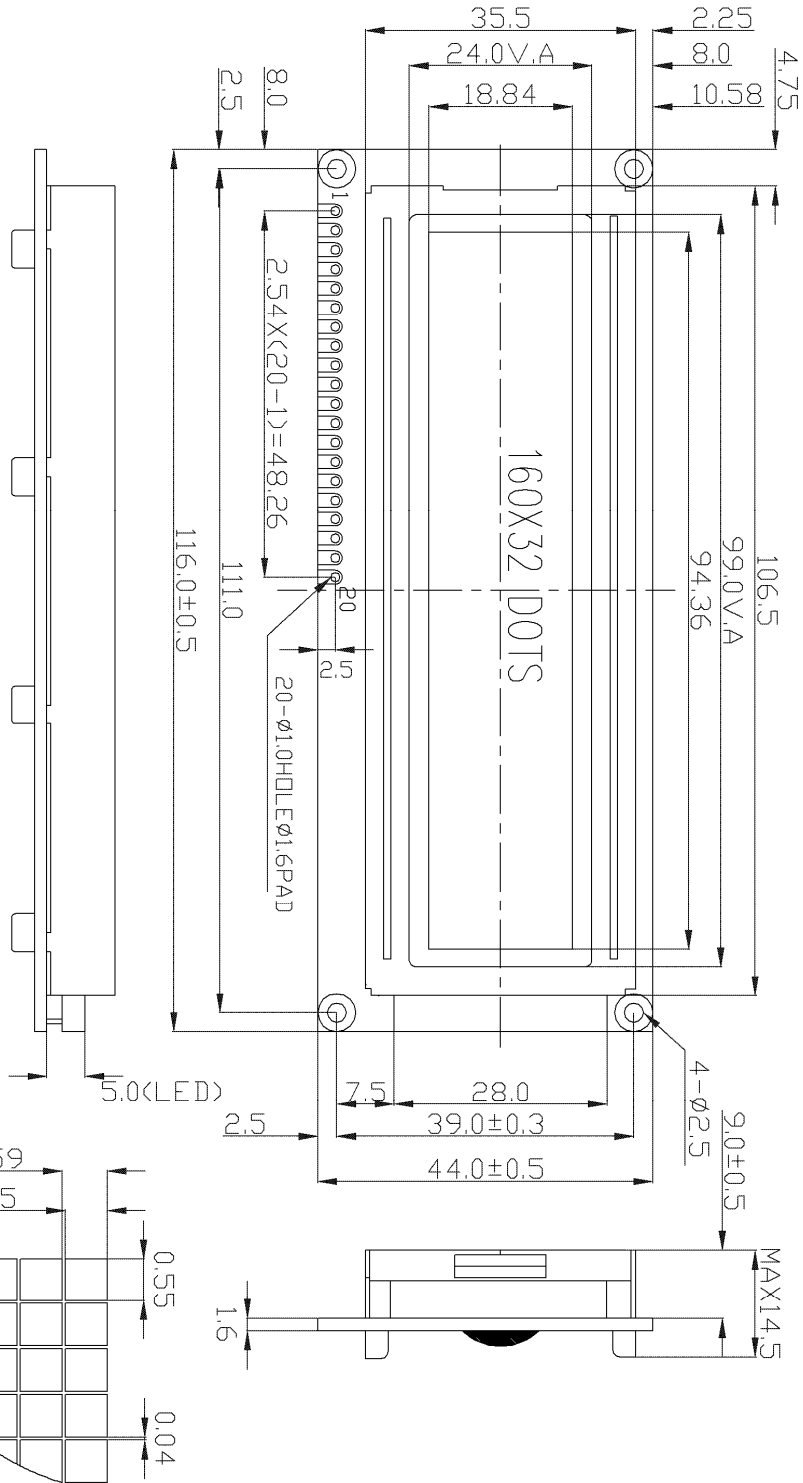

Pin No.	1	2	3	4	5	6	7	8~15	16	17	18	19	20
Symbol	A0	/CS2	/CS1	/RD	/WR	V <sub>DD</sub>	V <sub>SS</sub>	DB0~DB7	RES	V <sub>O</sub>	V <sub>EE</sub>	LEDA	LEDK

Modify History

Mark	Date	Description	Drwn.	Drwn.

GEM-TECH ELEC. CO., LTD.

P. N.	GTG-160324
File No.	160324-0
Date:	2013.06.05
Sub. No.	3
Unit:	mm
Umatic Tolerance	±0.3

The tolerance unless specified: ±0.3mm

## 9.QUALITY SPECIFICATION

### 9-1.ACCEPTABLE QUALITY LEVEL

Inspection items	Sampling procedures	AQL
Visual-operating (Electro-optical)	GB2828.1-2003 Inspection level II Normal inspection Single sample inspection	0.65
Visual-not operating	GB2828.1-2003 Inspection level II Normal inspection Single sample inspection	1.5
Dimension measurement	GB2828.1-2003 Inspection level II Normal inspection Single sample inspection	1.5

### 9-2. INSPECTION CONDITIONS

#### 9-2-1. THE ENVIRONMENTAL

-Room temperature:  $25 \pm 3^{\circ}\text{C}$

-Humidity:  $65 \pm 20\%\text{RH}$

### 9-3. INSPECTION STANDARDS

#### 9-3-1. VISUAL WHILE OPERATING

Items to be inspected	Inspection standard
. No display	. If any pattern is not active at all, they can be rejected.
. Irregular operating	. No irregular operating are allowed . Appeared different display, which they should be chosen in the pattern, or appeared in different position where they should be chosen.
.Irregular display	. Any segment doesn't active, they can be rejected.
. Over current	. The total current required to activate the module should not be exceed the MAX current in specification.
.View angles	. Valves that don't meet the minimum value noted in the specification. they can be rejected.
.Contrast	. Valves that don't meet the minimum value noted in the specification, they can be reject.
.LCD operate voltage	. Meet the specification.

#### 9-3-2. Visual while not operating

Module dimension	. Meet the module outline drawing, not exceed the tolerance.
LCD panel scratch	.Following scratches inside the effective viewing area considered as the defects when their width & length are larger than the following combinations. Number: one or more Width: 0.1 length: 3.0 three or more Width: 0.05 length: 2.0 three or more Width: 0.03 length: 3.0 When the defects exceed this, it can be rejected.

---

## 10.RELIABILITY

### Standard Specification for Reliability of General-purpose LCM

Test Item	Test Condition	Note
High Temperature Store	80 °C,200hr.	2
Low Temperature Store	-30 °C,200hr	2
Humidity Store	40 °C,90%RH,96hr	1,2
High Temperature Operation	70 °C,typical operating conditions,200hr	
Low Temperature Operation	-20 °C,typical operating conditions,200hr	
Temperature Cycling	-10 °C~25 °C~60 °C~25 °C 10 min. between each step temp 50 min. at each step. 5 cycles	1,2
Mechanical Vibration	10~55Hz sweep, 3G, ampl.=10mm(max) XYZ for 10 min, each.	

Note 1: Condensation of water is not permitted on the module.

Note 2: The module should be inspected after 1 hour storage in normal conditions (15~35 °C,45~65%RH)

## 11. HANDLING PRECAUTION

### 11-1. MOUNTING METHOD

The panel of the LCD module consists of two thin glass plates with polarizes which easily get damaged since the module is fixed by utilizing fitting holes in the printed circuit board. Extreme care should be taken when handling the LCD modules.

### 11-2. CAUTION OF LCD HANDLING & CLEANING

When cleaning the display surface. Use soft cloth with solvent (recommended below) and wipe lightly.

- Isopropyl alcohol
- Ethyl alcohol
- Tri chlorotri fluoroethane

Do not wipe the display surface with dry or hard materials that will damage the polarizes surface.

Do not use the following solvent:

- Water
- Ketone
- Aromatics

### 11-3.CAUTION AGAINST STATIC CHARGE

The LCD modules use COMS LSI drivers. So we recommend that you connect any unused input terminal to Vdd or Vss, do not input any signals before power is turned on and ground your body. work/assembly table. And assembly equipment to protect against static electricity.

### 11-4.PACKAGING

-Modules use LCD elements, and must be treated as such avoid intense shock and falls from a height

-To prevent modules from degradation, do not operate or store them exposed directly to sunshine or high temperature/humidity.

---

### 11-5.CAUTION FOR OPERATION

-It is indispensable to drive LCM within the specified voltage limit since the higher voltage than the limit shortens LCM life.

-Response time will be extremely delayed at lower temperature than the operating temperature range and on the other hand at higher temperature LCD show dark color in them.

However those phenomena do not mean malfunction or out of order with LCD, which will come back in the specified operating temperature range.

-If the display area is pushed hard during operation. Some font will be abnormally displayed but it resumes normal condition after turning off once.

-A slight dew depositing on terminals is a cause for Electro-chemical reaction resulting in terminal open circuit.

Under the maximum operating temperature, 50%RH or less is required

### 11-6 STORAGE

In the case of storing for a long period of time (for instance, for years) for the purpose or replacement use. the following ways are recommended

-Storage in a polyethylene bag with the opening sealed so as not to enter fresh air outside in it, and with no desiccant.

-Placing in a dark place where neither exposure to direct sunlight nor light is, keeping temperature in the specified storage temperature range.

-Storing with no touch on polarizes surface by the anythingelse.

(it is recommended to store them as they have been contained in the inner container at the time of delivery from us.

### 11-7.SAFETY

-It is recommendable to crash damaged or unnecessary LCD into pieces and wash off liquid crystal by using solvents such as acetone and ethanol, which should be burned up later.

-When any liquid crystal leaked out of a damaged glass cell comes in contact with your hands, please wash it off well with soap and water.

## 12.PRECAUTION FOR USE

12-1.A limit sample should be provided by the both parties on an occasion when the both parties agree its necessity.

Judgement by a limit sample shall take effect after the limit sample has been established and confirmed by the both parties.

12-2.On the following occasions, the handling of problem should be decided through discussion and agreement between representative of the both parties

-When a question is arisen in this specification.

-When a new problem is arisen which is not specified in this specifications.

-When an inspection specification change or operating condition change in customer is reported to GEM-TECH, and some problem is arisen in this specification due to the change.

-When a new problem is arisen at the customer's operating set for sample evaluation in the customer size.



---

### 13. REVISIONS HISTORY

REVISION	DATE	DESCRIPTION
1.0	2013-7-24	First release
1.1	2013-8-7	Update the LED brightness.
1.2	2013-9-29	Add 12:00 mode.