

PRODUCT SPECIFICATION

GS12864C-Q-BSXTSWW-100

V1.0

November 22, 2006

 Eastertronic LCD Group

REVISION RECORD

REV	DESCRIPTION	DATE
V1.0	First issue	November 22, 2006



CONTENTS

SECTIONS	DESCRIPTION	PAGE NO.
1.	TYPE NUMBER AND DESCRIPTION	4
2.	LCD MODULE NUMBERING SYSTEM	5
3.	MECHANICAL SPECIFICATIONS.....	6
4.	ELECTRICAL BLOCK DIAGRAM.....	7
4.1	Pins Definition	
4.2	Electrical Block Diagram	
5.	ABSOLUTE MAXIMUM RATINGS.....	8
5.1	Electrical Maximum Ratings	
5.2	Environmental Conditions	
6.	ELECTRICAL SPECIFICATIONS.....	8
6.1	Electrical Characteristics	
6.2	Timing Specifications	
7.	POWER SUPPLY FOR LCD MODULE.....	9
8.	ELECTRO-OPTICAL CHARACTERISTIC.....	10
9.	INSTRUCTION TABLE.....	12
10.	PRECAUTION FOR USING LCM.....	13
11.	Declaration of conformity regarding the limitation of dangerous substances	14

1. Type Number and Description

Type Number	:	GS12864C-Q-BSXTSWW-100
Description	:	128 X 64 dots
LCD Panel	:	Blue STN, Negative, Transmissive
Operating Temperature:		-20 °C – 70 °C
Storage Temperature	:	-30 °C – 80 °C
Viewing angle	:	6H
Backlight Voltage	:	3.2 V
BackLight Mode	:	Side
BackLight Color	:	White
Controller	:	T6963C
IC Package	:	QFP
Logic Voltage	:	5.0V

2. LCD Module Numbering System

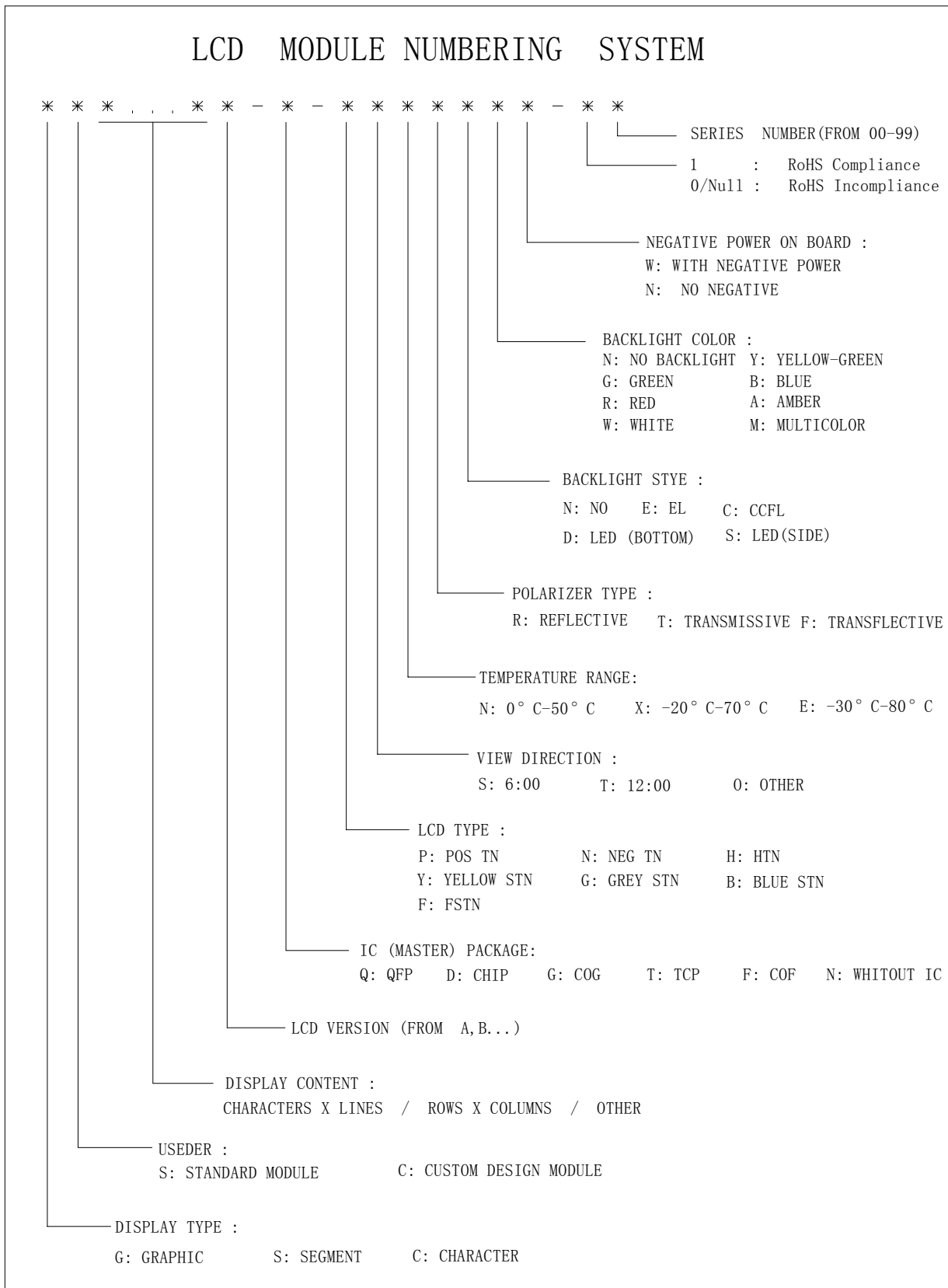

3. Mechanical Specifications:

ITEM	STANDARD VALUE	UNIT
DISPLAY CONTENT	128H X 64V DOTS	
MODULE DIMENSION	93.0(W) X 70.0(H) X 13.0(T)	mm
EFFECTTVE DISPLAY AREA	72.0(W) X 40.0(H)	mm
DOT SIZE	0.48(W) X 0.48(H)	mm
DOT PITCH	0.52(W) X 0.52(H)	mm
APPROX WEIGHT	100	g
LCD TYPE	Blue STN, Neg. , Transmissive	
DUTY AND BIAS	1/64 DUTY; 1/9 BIAS	
VIEWING DIRECTION	6:00	
BACK LIGHT	WHITE SIDE LED	

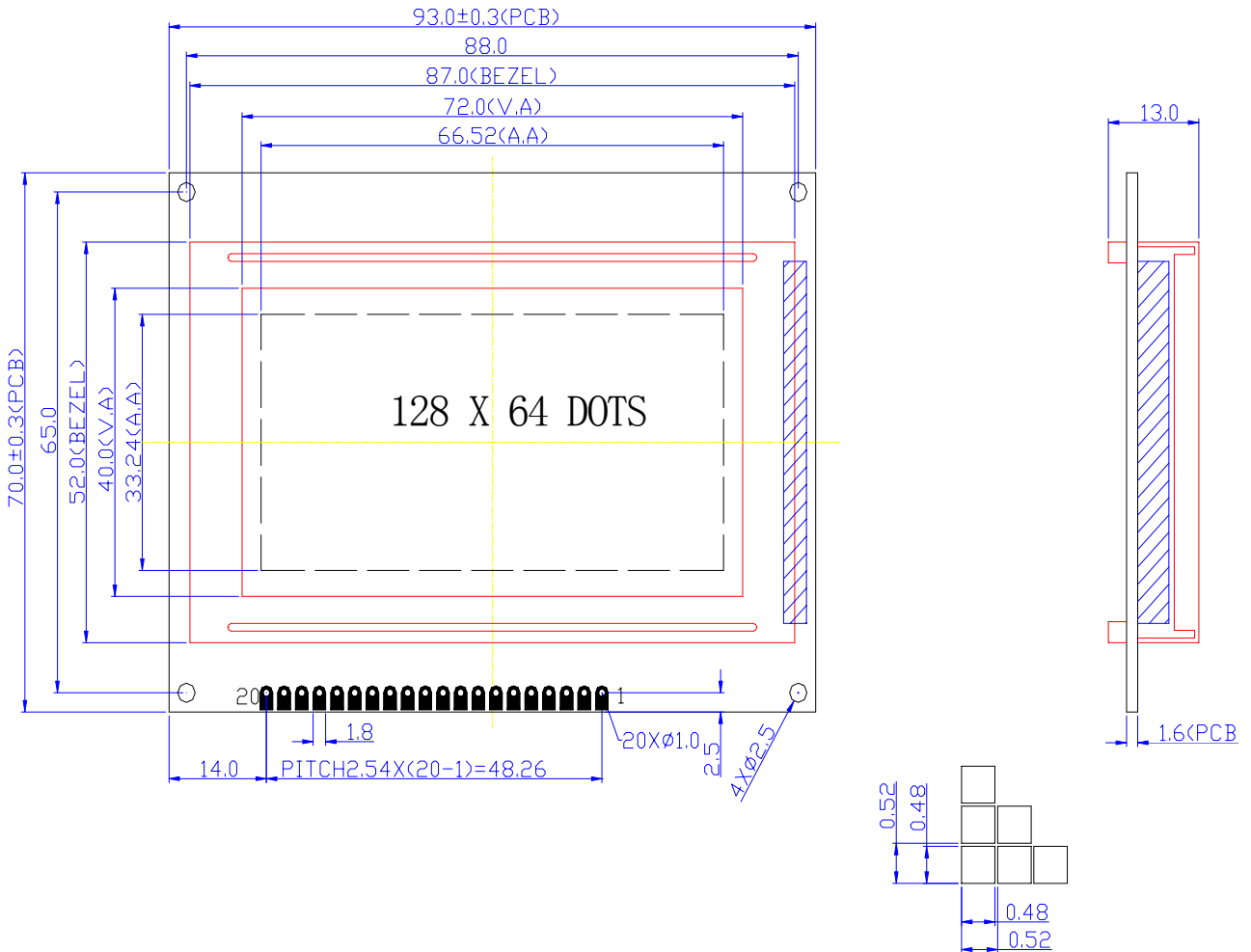

4. ELECTRICAL BLOCK DIAGRAM/PINS DEFINITION

4.1 PINS DEFINITION

PIN	SYMBOL	FUNCTION
1	FG	(Frame) GND
2	VSS	Power Supply for logic
3	VDD	GND(0V)
4	VEE	Negative Voltage Supply
5	WR	L Write
6	RD	L Read
7	CE	L Enable
8	D/C	H: Data L: Instruction
9	/RST	Reset signal
10–17	DB0-DB7	Data Bus
18	FS	Select character style
19	A	Power Supply for LED B/L(+)
20	K	Power Supply for LED B/L(-)

4.2 ELECTRICAL BLOCK DIAGRAM

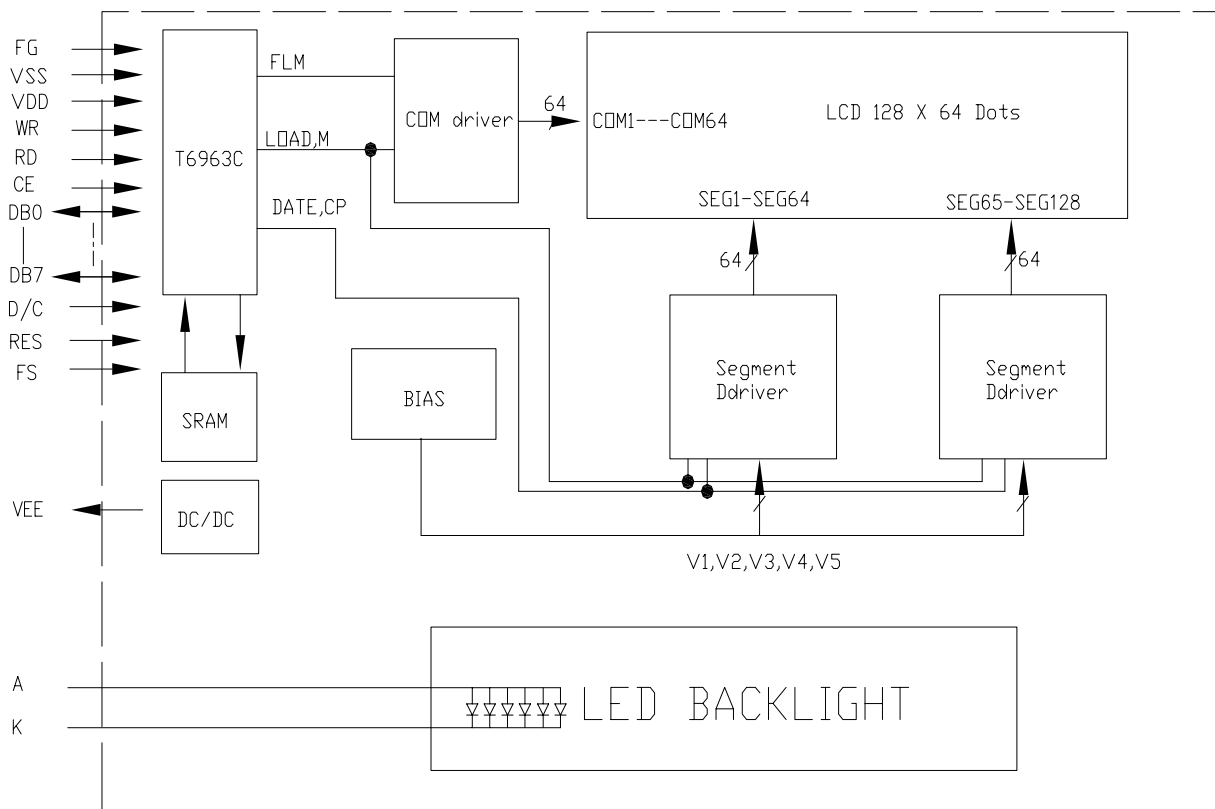

5. ABSOLUTE MAXIMUM RATINGS

5.1 Electrical Maximum Ratings (Ta=25deg C)

ITEM	SYMBOL	CONDITION	MIN	MAX	UNIT
Supply Voltage (Logic)	Vdd – Vss	25 C	0	7.0	V
Supply Voltage (LCD Drive)	Vdd – Vee	25 C	-	18.0	V
Input Voltage	Vi	-	-0.3	Vdd +0.3	V

5.2 Environmental Conditions

ITEM	SYMBOL	CONDITION	MIN	MAX	UNIT
Operating Temp	Topr	-	-20	70	deg C
Storage Temp	Ttsg	-	-30	80	deg C
Humidity Endurance	RH	no condensation Ta</=40 deg	-	95	%
Vibration	-	3 directions	see note (a), page 3		-
Shock	-	3 directions	see note (b), page 3		-

note (a): frequency : varying from 10 Hz in a 1-minute cycle
amplitude : 1.5mm
duration : 120 cycles, each lasting 1 minute,
for each of the 3 directions, x,y,z

note (b): mutually perpendicular directions
direction normal to surface of LCD glass
80G, half-sine pulse of duration 11ms
other 2 directions
100G, half-sine pulse of duration 11ms

6. ELECTRICAL SPECIFICATIONS

6.1 Electrical Characteristics at Ta=25 deg C, Vdd = 5V + / - 5%

ITEM	SYMBOL	CONDITION	MIN	TYP	MAX	UNIT
Supply Voltage (logic)	Vdd-Vss	-	4.5	5.0	5.5	V
Supply Voltage (LCD)	Vdd-V0	Vdd = 5V	--	12.5	--	V
Input signal voltage (for E, DB0-7,R/W,RS)	Vih	"H" level	2.4	-	Vdd	V
	Vil	"L" level	0	-	0.6	V
Output voltage for Logic	Voh	-Ioh=0.6mA	Vdd-0.4	-	Vdd	V
	Vol	Iol=1.6mA	0	-	0.4	V
Supply Current	Idd	-	--	8.0	10.0	mA
Supply Voltage (LED)	V-bl		2.9	3.2	3.5	V
Supply Current (LED)	I-bl			90	150	mA

6.2 TIMING SPECIFICATIONS at $T_a = 25 \text{ deg C}$, $V_{DD} = 5V \pm 10\%$, $V_{SS} = 0V$

Bus Timing

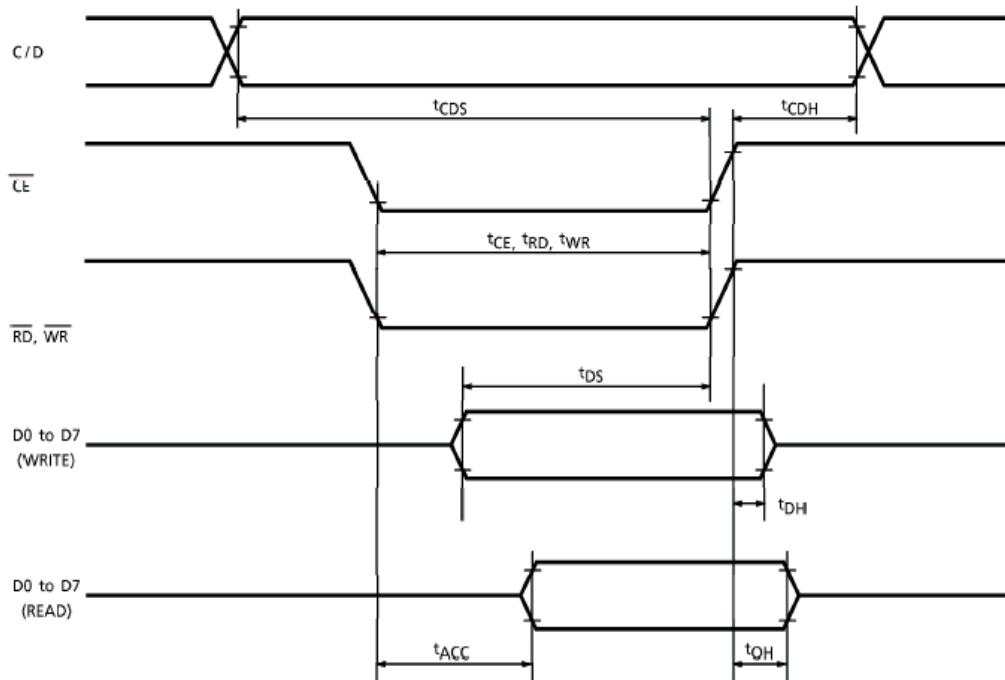

TEST CONDITIONS (Unless otherwise noted, $V_{DD} = 5.0V \pm 10\%$, $V_{SS} = 0V$, $T_a = -20 \text{ to } 75^\circ\text{C}$)

ITEM	SYMBOL	TEST CONDITIONS	MIN	MAX	UNIT
C/D Set-up Time	t_{CDS}	—	100	—	ns
C/D Hold Time	t_{CDH}	—	10	—	ns
\overline{CE} , \overline{RD} , \overline{WR} Pulse Width	t_{CE}, t_{RD}, t_{WR}	—	80	—	ns
Data Set-up Time	t_{DS}	—	80	—	ns
Data Hold Time	t_{DH}	—	40	—	ns
Access Time	t_{ACC}	—	—	150	ns
Output Hold Time	t_{OH}	—	10	50	ns

7. POWER SUPPLY FOR LCD MODULE

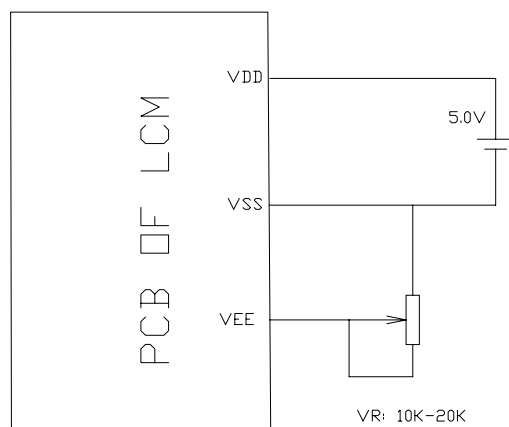

8. ELECTRO-OPTICAL CHARACTERISTIC

ITEM	SYMBOL	CONDITIO ON	MIN.	TYP.	MAX.	UNIT	REF.
Contrast	CR	25°C	--	12	--		Note1
Rise Time	tr	25°C	--	160	240	ms	Note2
Fall Time	tf	25°C	--	100	150	ms	note 2
Viewing Angle	$\theta 1 - \theta 2$	25°C	--	--	60	DEG	Note 3
	$\varnothing 1, \varnothing 2$		-40	--	40		
Frame Frequency	Ff	25°C	--	70	--	Hz	note 2

Note(3): Contrast ratio is defined under the following condition:

$$CR = \frac{\text{brightness of non-selected condition}}{\text{brightness of selected condition}}$$

- (a). Temperature-----25C
- (b). Frame Frequency-----64Hz
- (c). Viewing angle----- $\theta = 0, \varnothing = 0$
- (d). Operating Voltage---5.0V

Note(1): definition of response time:

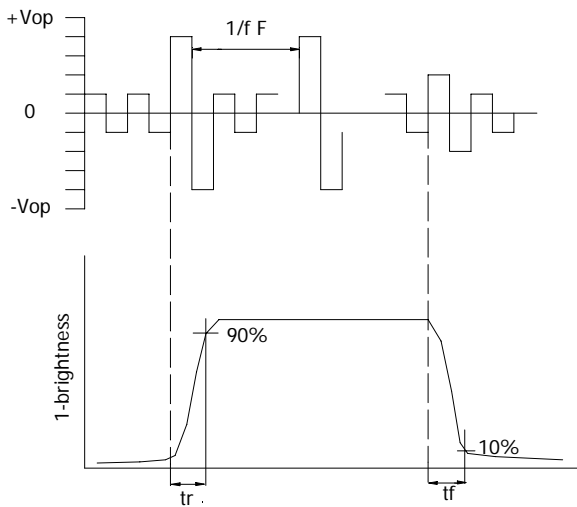

Condition:

- (a). Temperature-----25C
- (b). Frame Frequency-----64Hz
- (c). Viewing angle----- $\theta = 0, \varnothing = 0$
- (d). Operating Voltage---5.0V

Note(2): definition of view angle:

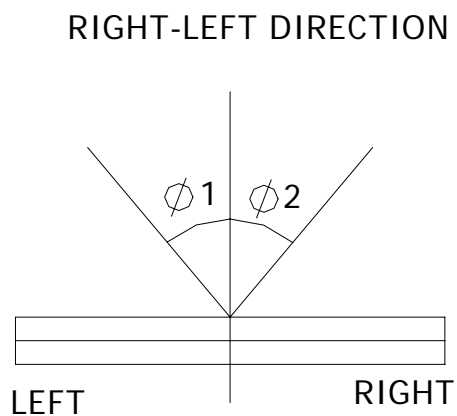
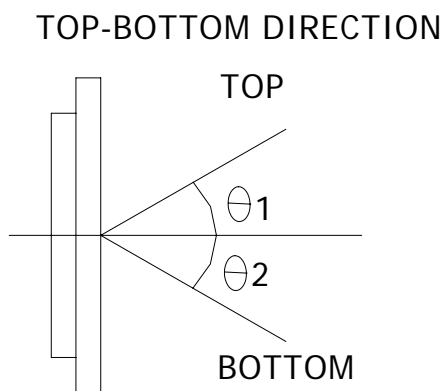

9. INSTRUCTION TABLE

COMMAND	CODE	D1	D2	FUNCTION
REGISTERS SETTING	00100001	X address	Y address	Set Cursor Pointer
	00100010	Data	00H	Set Offset Register
	00100100	Low address	High address	Set Address Pointer
SET CONTROL WORD	01000000	Low address	High address	Set Text Home Address
	01000001	Columns	00H	Set Text Area
	01000010	Low address	High address	Set Graphic Home Address
	01000011	Columns	00H	Set Graphic Area
MODE SET	1000X000	—	—	OR mode
	1000X001	—	—	EXOR mode
	1000X011	—	—	AND mode
	1000X100	—	—	Text Attribute mode
	10000XXX	—	—	Internal CG ROM mode
	10001XXX	—	—	External CG RAM mode
DISPLAY MODE	10010000	—	—	Display off
	1001XX10	—	—	Cursor on, blink off
	1001XX11	—	—	Cursor on, blink on
	100101XX	—	—	Text on, graphic off
	100110XX	—	—	Text off, graphic on
	100111XX	—	—	Text on, graphic on
CURSOR PATTERN SELECT	10100000	—	—	1-line cursor
	10100001	—	—	2-line cursor
	10100010	—	—	3-line cursor
	10100011	—	—	4-line cursor
	10100100	—	—	5-line cursor
	10100101	—	—	6-line cursor
	10100110	—	—	7-line cursor
	10100111	—	—	8-line cursor
DATA AUTO READ / WRITE	10110000	—	—	Set Data Auto Write
	10110001	—	—	Set Data Auto Read
	10110010	—	—	Auto Reset
DATA READ / WRITE	11000000	Data	—	Data Write and Increment ADP
	11000001	—	—	Data Read and Increment ADP
	11000010	Data	—	Data Write and Decrement ADP
	11000011	—	—	Data Read and Decrement ADP
	11000100	Data	—	Data Write and Nonvariable ADP
	11000101	—	—	Data Read and Nonvariable ADP
SCREEN PEEK	11100000	—	—	Screen Peek
SCREEN COPY	11101000			Screen Copy

X : invalid

10. Precaution For Using LCM

1. LIQUID CRYSTAL DISPLAY (LCD)

LCD is made up of glass, organic sealant, organic fluid, and polymer based polarizers. The following precautions should be taken when handling,

- (1). Keep the temperature within range of use and storage. Excessive temperature and humidity could cause polarization degradation, polarizer peel off or bubble.
- (2). Do not contact the exposed polarizers with anything harder than an HB pencil lead. To clean dust off the display surface. Wipe gently with cotton. Chamois or other soft material soaked in petroleum benzine.
- (3). Wipe off saliva or water drops immediately. Contact with water over a long period of time may cause polarizer deformation or color fading, while an active LCD with water condensation on its surface will cause corrosion of ITO electrodes.
- (4). Glass can be easily chipped or cracked from rough handling, especially at corners and edges.
- (5). Do not drive LCD with DC voltage.

2. Liquid Crystal Display Modules

2.1 Mechanical Considerations

LCM are assembled and adjusted with a high degree of precision. Avoid excessive shocks and do not make any alterations or modifications. The following should be noted.

- (1). Do not tamper in any way with the tabs on the tabs on the metal frame.
- (2). Do not modify the PCB by drilling extra holes, changing its outline, moving its components or modifying its pattern.
- (3). Do not touch the elastomer connector, especially insert a backlight panel (for example, EL).
- (4). When mounting a LCM make sure that the PCB is not under any stress such as bending or twisting. Elastomer contacts are very delicate and missing pixels could result from slight dislocation of any of the elements.
- (5). Avoid pressing on the metal bezel, otherwise the elastomer connector could be deformed and lose contact, resulting in missing pixels.

2.2. Static Electricity

LCM contains CMOS LSI's and the same precaution for such devices should apply, namely

- (1). The operator should be grounded whenever he/she comes into contact with the module. Never touch any of the conductive parts such as the LSI pads, the copper leads on the PCB and the interface terminals with any parts of the human body.
- (2). The modules should be kept in antistatic bags or other containers resistant to static for storage.
- (3). Only properly grounded soldering irons should be

used.

- (4). If an electric screwdriver is used, it should be well grounded and shielded from commutator sparks.
- (5). The normal static prevention measures should be observed for work clothes and working benches; for the latter conductive (rubber) mat is recommended.
- (6). Since dry air is inductive to statics, a relative humidity of 50-60% is recommended.

2.3. Soldering

- (1). Solder only to the I/O terminals.
- (2). Use only soldering irons with proper grounding and no leakage.
- (3). Soldering temperature: $280\text{ }^{\circ}\text{C} \pm 10^{\circ}\text{C}$
- (4). Soldering time: 3 to 4 sec.
- (5). Use eutectic solder with resin flux fill.
- (6). If flux is used, the LCD surface should be covered to avoid flux spatters. Flux residue should be removed after wards.

2.4. Operation

- (1). The viewing angle can be adjusted by varying the LCD driving voltage V_0 .
- (2). Driving voltage should be kept within specified range; excess voltage shortens display life.
- (3). Response time increases with decrease in temperature.
- (4). Display may turn black or dark blue at temperatures above its operational range; this is (however not pressing on the viewing area) may cause the segments to appear "fractured".
- (5). Mechanical disturbance during operation (such as pressing on the viewing area) may cause the segments to appear "fractured".

2.5. Storage

If any fluid leaks out of a damaged glass cell, wash off any human part that comes into contact with soap and water. Never swallow the fluid. The toxicity is extremely low but caution should be exercised at all the time.

2.6. Limited Warranty

Unless otherwise agreed between EASTERNTRONIC and customer, EASTERNTRONIC will replace or repair any of its LCD and LC, which is found to be defective electrically and visually when inspected in accordance with EASTERNTRONIC acceptance standards, for a period on one year from date of shipment. Confirmation of such date shall be based on freight documents. The warranty liability of EASTERNTRONIC is limited to repair and/or replacement on the terms set forth above. EASTERNTRONIC will not be responsible for any subsequent or consequential events.

11. Declaration of conformity regarding the limitation of dangerous substances

深圳易事通液晶显示模块有限公司

SHENZHEN EASTERNTRONIC LCM CO., LTD.

4F, B3 Building, FuYuan Industrial Zone, FuYong Town,

BaoAn District, ShenZhen, P.R.China

DECLARATION OF CONFORMITY REGARDING THE LIMITATION OF DANGEROUS SUBSTANCES

WE, SHENZHEN EASTERNTRONIC LCM CO., LTD,

Declare that the product of GS12864C-Q-BSXTSWW-100 complies with:

The directive 2002/95/EC Dated 2003/01/27 regarding the limitation of dangerous substances, in particular to clause 4 which forbids the use of the following elements:

- Lead
- Mercury
- Cadmium
- Hexavalent chromium
- Polybrominated biphenyls
- Polybrominated diphenylethers

And to the annex which points out the exempted implementations

 To the directive 73/23/eec dated 1973/02/19 and the standard EN60335-1 regarding prohibition of following elements:

- Oils containing polychlorinated biphenyl
- Asbestos
- Radioactive substances

Name: Ewing Liu /

SHENZHEN EASTERNTRONIC LCM CO., LTD.

Issued on November 22, 2006

According with the proposal of Technical Adaption Committee(TAC) of a limit of 0.1% by weight for lead hexavalent chromium, mercury, PBBs and PBDRs and 0.01% by weight for Cadmium.