

PRODUCT SPECIFICATION

GS12864B-D-BSXTSWW-100

V1.0

November 21, 2007

 Eastertronic LCD Group

REVISION RECORD

REV	Description	Data
V1.0	First issue	November 21, 2007

CONTENTS

SECTIONS	DESCRIPTION	PAGE NO.
1.	LCD Module Numbering System	4
2.	Type Number and Description	5
3.	Mechanical Specifications	6
4.	Electrical Block Diagram	7
	4.1 Pins Definition	
	4.2 Electrical Block Diagram	
5.	Absolute Maximum Ratings	8
	5.1 Electrical Maximum Ratings	
	5.2 Environmental Conditions	
6.	Electrical Specifications	9
	6.1 Electrical Characteristics	
	6.2 Timing Specifications	
7.	Power Supply For LCD Module	10
8.	Electro-Optical Characteristic	11
9.	Instruction Table	13
10.	Precaution for Using LCM	17
11.	Declaration of conformity regarding the limitation of dangerous substances	18

1. LCD Module Numbering System

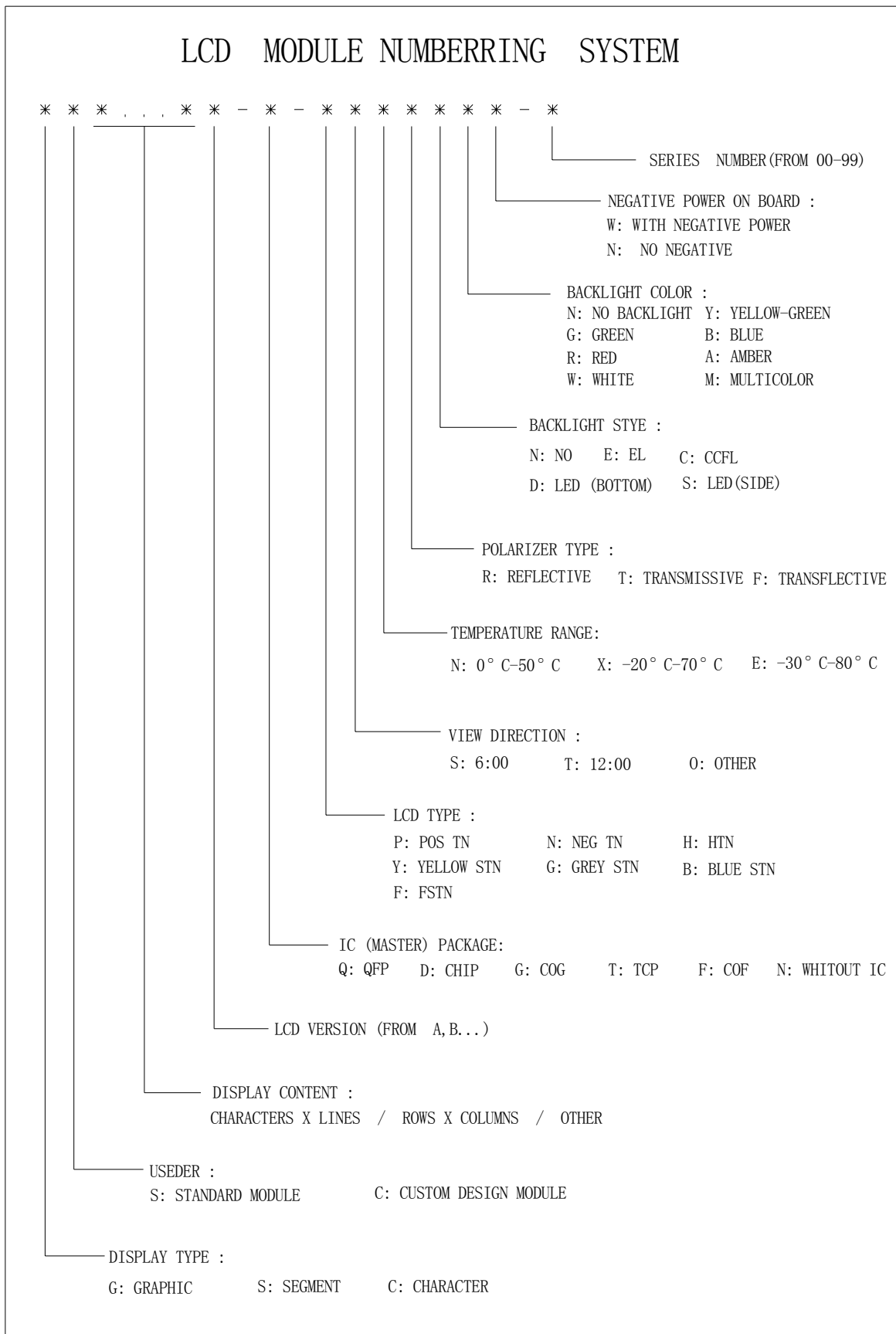

2. TYPE NUMBER AND DESCRIPTION

Type Number	:	GS12864B-D-BSXTSWW-100
Description	:	128 X 64 DOTS
LCD Panel	:	Blue STN, Negative , Transmissive
Viewing angle	:	6H
Duty	:	1/64
Bias	:	1/9
Backlight Mode	:	Side, White LED
Logic Voltage	:	5.0V
Operating Temperature	:	-20°C--70°C
Storage Temperature	:	-30°C --80°C
Controller	:	KS0107 & KS0108 or equivalent
Package	:	Bonding
DC-DC converter	:	With

3. MECHANICAL SPECIFICATIONS:

ITEM	STANDARD VALUE	UNIT
DISPLAY CONTENT	128 H X 64 V DOTS	
MODULE DIMENSION	75.0 (W) X 52.7 (H) X 8.8 (H)	mm
DISPLAY AREA	60.5 (W) X 33.0 (H)	mm
DOT SIZE	0.39 (W) X 0.39 (H)	mm
DOT PITCH	0.43 (W) X 0.43 (H)	mm
LCD TYPE	Blue STN, Negative, Transmissive	
DUTY AND BIAS	1/64 DUTY; 1/9 BIAS	
VIEWING DIRECTION	6:00	
BACK LIGHT	Side, White LED	

MODULE DIMENSION DRAWING

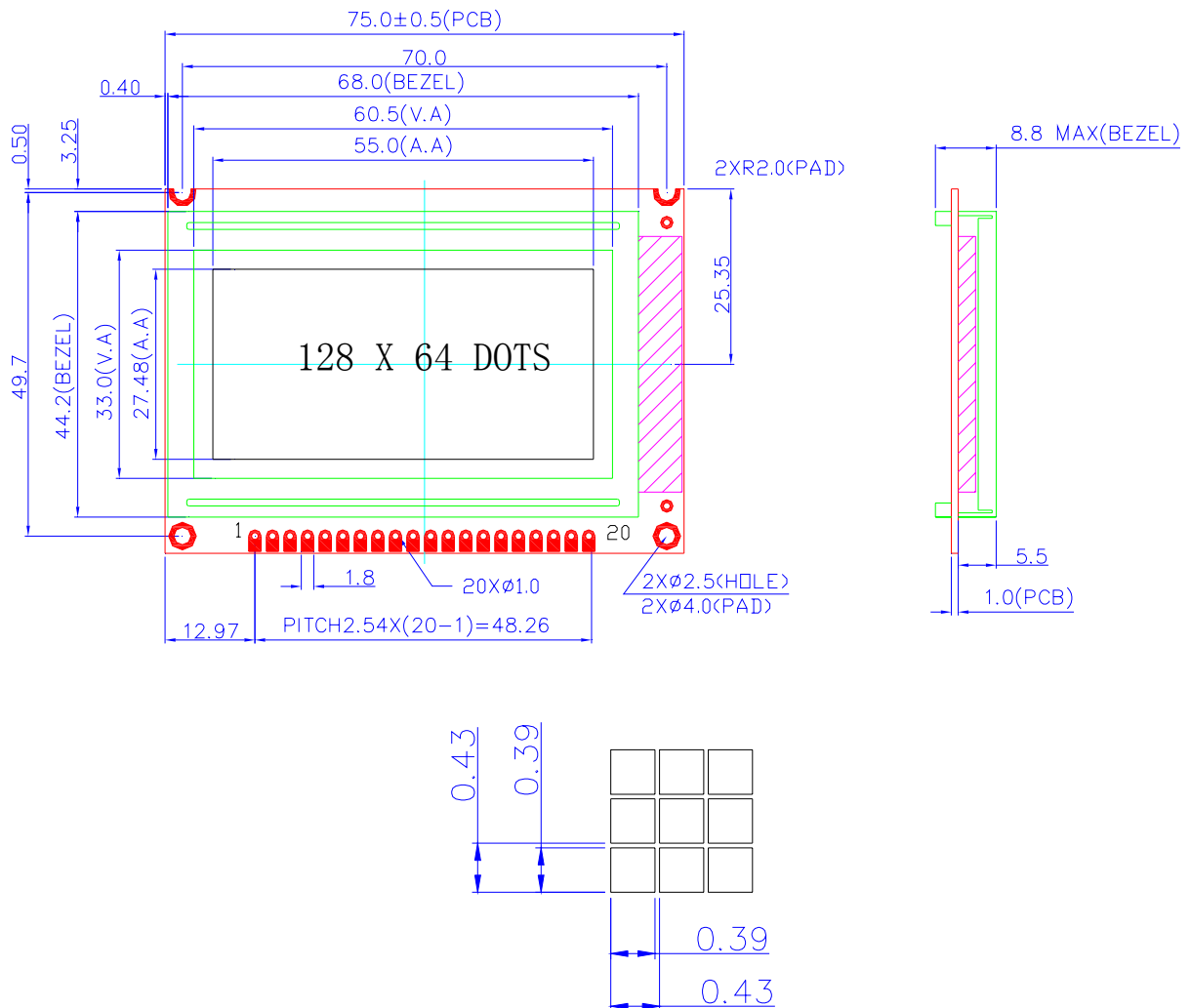

4. ELECTRICAL BLOCK DIAGRAM

4.1 PIN DEFINITION

PIN	SYMBOL	FUNCTION
1	VDD	POWER SUPPLY (+5V)
2	VSS	POWER SUPPLY (GND)
3	VO	CONTRAST ADJUST
4	DB0	DATA BUS
5	DB1	DATA BUS
6	DB2	DATA BUS
7	DB3	DATA BUS
8	DB4	DATA BUS
9	DB5	DATA BUS
10	DB6	DATA BUS
11	DB7	DATA BUS
12	/CS1	SELECT CHIP1 L active
13	/CS2	SELECT CHIP2 L active
14	/RST	RESET SIGNAL
15	R/W	READ OR WRITE (H: DATA APPEARS AT DATA BUS)
16	RS	DATA OR INSTRUCTION(H: DISPLAY RAM DATA)
17	E	ENABLE SIGNAL
18	VEE	NEGATIVE VOLTAGE
19	A	POWER SUPPLY FOR BACKLIGHT (+)
20	K	POWER SUPPLY FOR BACKLIGHT (-)

4.2 ELECTRICAL BLOCK DIAGRAM

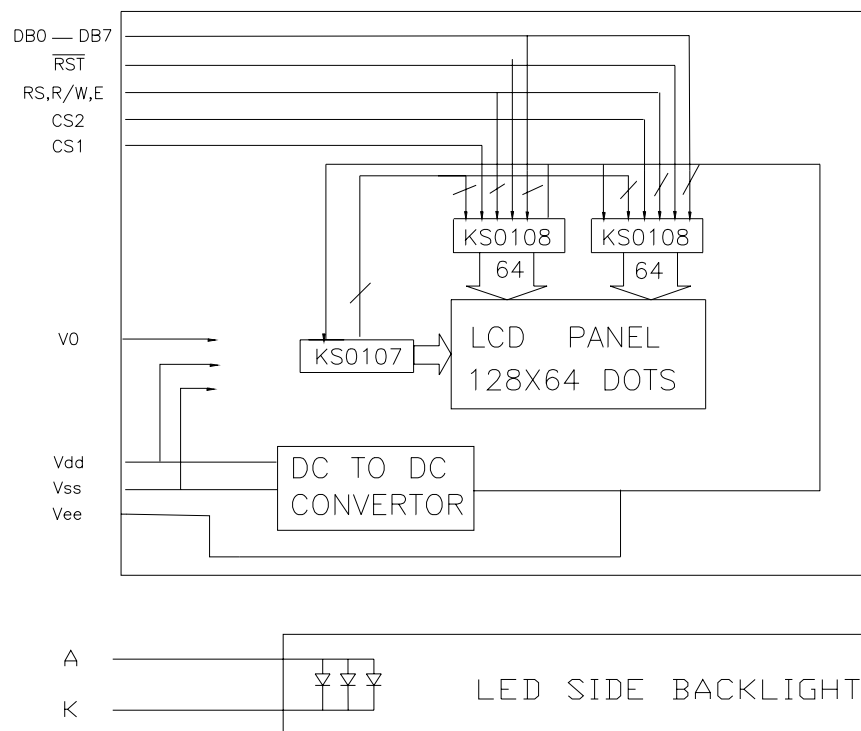

5. ABSOLUTE MAXIMUM RATINGS

5.1 Maximum Absolute Limit

Characteristic	Symbol	Value	Unit	Note
Operating Voltage	V _{DD}	-0.3~+7.0	V	NOTE*1
Supply Voltage	V _{EE}	V _{DD} -19.0~V _{DD} +0.3	V	NOTE*4
Driver Supply Voltage	V _B	-0.3~V _{DD} +0.3	V	NOTE*1,3
	V _{LCD}	V _{EE} -0.3~V _{DD} +0.3	V	NOTE*2
Operating Temperature	T _{OPR}	-30~+85	°C	
Storage Temperature	T _{STG}	-55~+125	°C	

NOTE*1. Based on VSS=0V .

NOTE*2 Applies the same supply voltage to VEE1 and VEE2. V_{LCD}=V_{DD}-V_{EE}

NOTE*3 Applies to RSTB,CS1,CS2,E,R/W,RS DB0~DB7.

NOTE*4 Applies to V1,V2,V3,V4,V5.

5.2 Environmental Conditions

ITEM	SYMBOL	CONDITION	MIN	MAX	UNIT
Operating Temp	Topr	-	-20	70	deg C
Storage Temp	Ttsg	-	-30	80	deg C
Humidity Endurance	RH	no ondensation Ta</=40 deg	-	95	%
Vibration	-	3 directions	see note (a)		-
Shock	-	3 directions	see note (b)		-

note (a): frequency : varying from 10 Hz in a 1-minute cycle

amplitude : 1.5mm

duration : 120 cycles, each lasting 1 minute,

for each of the 3 directions, x,y,z

note (b): mutually perpendicular directions

direction normal to surface of LCD glass

80G, half-sine pulse of duration 11ms

other 2 directions

100G, half-sine pulse of duration 11ms

6. ELECTRICAL SPECIFICATIONS

6.1 ELECTRICAL CHARACTERISTICS (at Ta=25°C, Vdd=5.0±5%)

ITEM	SYMBOL	CONDITION	MIN	TYP	MAX	UNIT
Supply Volage(Logic)	Vdd-Vss	-	4.5	5.0	5.5	V
Supply Voltage(LCD)	VDD-Vo	Vdd=5.0V	-	12.6	-	V
Input Signal Voltage (for E,DB0-7,R/W,RS)	Vih	“H” Level	2.4	-	Vdd	V
	Vil	“L” Level	0	-	0.6	V
Output Voltage for Logic	Voh	-Ioh=0.6mA	Vdd- 0.4	-	Vdd	V
	Vol	Iol=1.6mA	0	-	0.4	
Supply Current	Idd	-	-	3.0	4.5	mA
Supply Voltage(LED)	V-bl	-	3.0	3.2	3.4	V
Supply Current(LED)	I-bl	-	-	45	75	mA

6.2 TIMING SPECIFICATIONS

ITEM	SYMBOL	MIN	MAX	UNIT
E Cycle Time	tc	1000	-	ns
E High Level Width	tWH	450		ns
E Low Level Width	tWL	450		ns
E rise time	tR	-	25	ns
E fall time	tF	-	25	ns
Address Set-Up Time	tASU	140	-	ns
Address Hold Time	tAH	10	-	ns
Data Set-up Time	tDSU	200	-	ns
Data Delay Time	tD	-	320	ns
Data Hold Time(Write)	tDHW	10		ns
Data Hold Time(Read)	tDHR	20		ns

WRITE MODE TIMING DIAGRAM

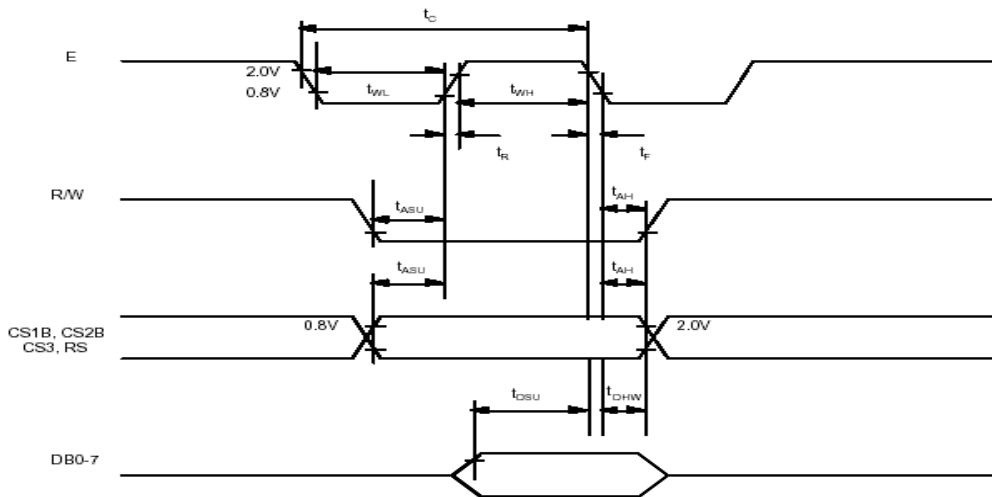

Fig 6. MPU write timing

READ MODE TIMING DIAGRAM

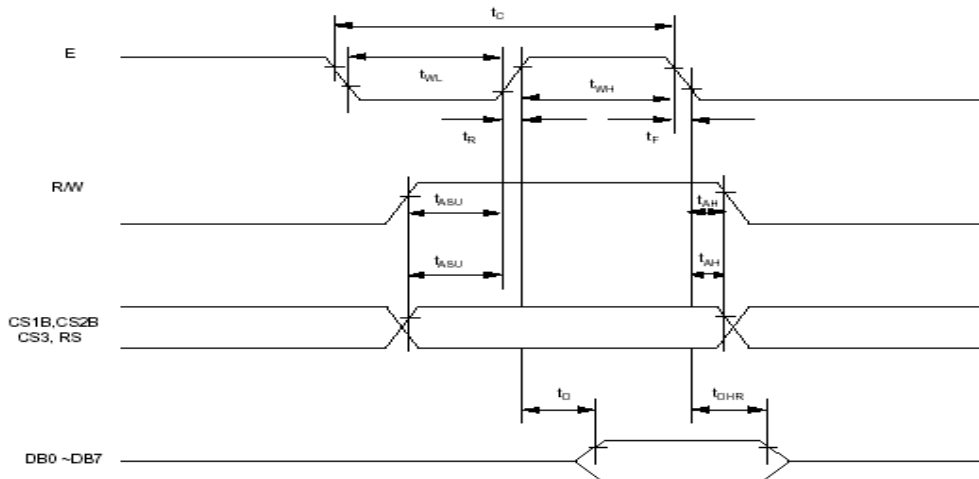
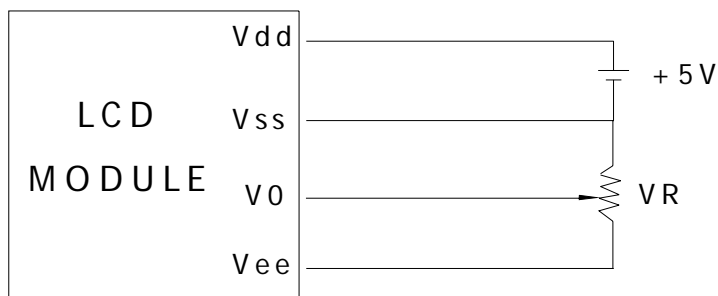

Fig 7. MPU Read timing

7. POWER SUPPLY FOR LCD MODULE



Vdd-V0: LCD Driving Voltage
 VR: 10K - 20K

8. ELECTRO-OPTICAL CHARACTERISTIC

ITEM	SYMBOL	CONDITION	MIN.	TYP.	MAX.	UNIT	REF.
Contrast	CR	25°C	--	12	--		Note1
Rise Time	tr	25°C	--	160	240	ms	Note2
Fall Time	tf	25°C	--	100	150	ms	note 2
Viewing Angle	θ1-θ2	25°C	--	--	60	DEG	Note 3
	Ø1, Ø2		-40	--	40		
Frame Frequency	Ff	25°C	--	70	--	Hz	note 2

Note(1): Contrast ratio is defined under the following condition:

$$CR = \frac{\text{brightness of selected condition}}{\text{brightness of non-selected condition}}$$

- (a). Temperature-----25C
- (b). Frame Frequency-----64Hz
- (c). Viewing angle----- $\theta=0, \text{Ø}=0$
- (d). Operating Voltage---12.6V

Note(2): definition of response time:

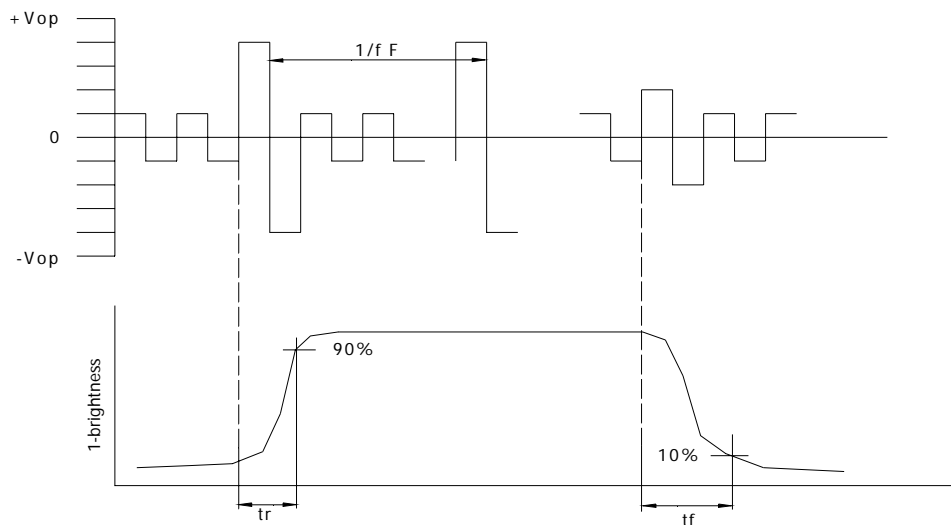

Condition:

- (a). Temperature-----25C
- (b). Frame Frequency-----64Hz
- (c). Viewing angle----- $\theta=0$, $\theta=0$
- (d). Operating Voltage---12.6V

Note(3): definition of view angle:

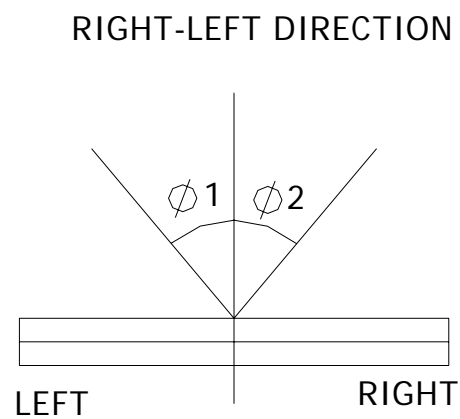
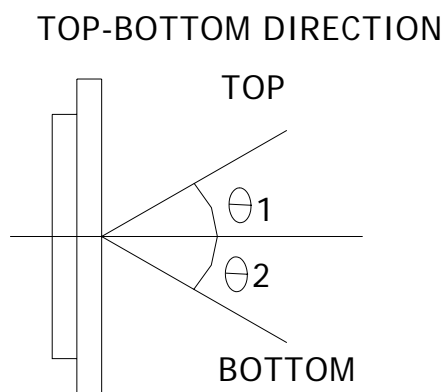

8. INSTRUCTION TABLE

Instruction	RS	R/W	DB7	DB6	DB5	DB4	DB3	DB2	DB1	DB0	Function
Display ON/OFF	L	L	L	L	H	H	H	H	H	L/H	Controls the display on or off. Internal status and display RAM data is not affected. L:OFF, H:ON
Set Address (Y address)	L	L	L	H	Y address (0~63)						Sets the Y address in the Y address counter.
Set Page (X address)	L	L	H	L	H	H	H	Page (0~7)			Sets the X address at the X address register.
Display Start Line (Z address)	L	L	H	H	Display start line (0~63)						Indicates the display data RAM displayed at the top of the screen.
Status Read	L	H	B U S Y	L	O N / O F F	R E S E T	L	L	L	L	Read status. BUSY L: Ready H: In operation ON/OFF L: Display ON H: Display OFF RESET L: Normal H: Reset
Write Display Data	H	L	Write Data								Writes data (DB0:7) into display data RAM. After writing instruction, Y address is increased by 1 automatically.
Read Display Data	H	H	Read Data								Reads data (DB0:7) from display data RAM to the data bus.

1. Display On/Off

RS	R/W	DB7	DB6	DB5	DB4	DB3	DB2	DB1	DB0
0	0	0	0	1	1	1	1	1	D

The display data appears when D is 1 and disappears when D is 0.

Though the data is not on the screen with D=0, it remains in the display data RAM.

Therefore, you can make it appear by changing D=0 into D=1.

2. Set Address (Y Address)

S	R/W	DB7	DB6	DB5	DB4	DB3	DB2	DB1	DB0
0	0	0	1	AC5	AC4	AC3	AC2	AC1	AC0

Y address (AC0 ~ AC5) of the display data RAM is set in the Y address counter.

An address is set by instruction and increased by 1 automatically by read or write operations of display data.

3. Set Page (X Address)

RS	R/W	DB7	DB6	DB5	DB4	DB3	DB2	DB1	DB0
0	0	1	0	1	1	1	AC2	AC1	AC0

X address(AC0 ~ AC2) of the display data RAM is set in the X address register.

Writing or reading to or from MPU is executed in this specified page until the next page is set.

4. Display Start Line (Z Address)

RS	R/W	DB7	DB6	DB5	DB4	DB3	DB2	DB1	DB0
0	0	1	1	AC5	AC4	AC3	AC2	AC1	AC0

Z address (AC0 ~ AC5) of the display data RAM is set in the display start line register and displayed at the top of the screen.
When the display duty cycle is 1/64 or others(1/32 ~ 1/64), the data of total line number of LCD screen, from the line specified by display start line instruction, is displayed.

5. Status Read

RS	R/W	DB7	DB6	DB5	DB4	DB3	DB2	DB1	DB0
1	0	BUSY	0	ON/OFF	RESET	0	0	0	0

- **BUSY**
When BUSY is 1, the Chip is executing internal operation and no instructions are accepted.
When BUSY is 0, the Chip is ready to accept any instructions.
- **ON/OFF**
When ON/OFF is 1, the display is on.
When ON/OFF is 0, the display is off.
- **RESET**
When RESET is 1, the system is being initialized.
In this condition, no instructions except status read can be accepted.
When RESET is 0, initializing has finished and the system is in the usual operation condition.

6. Write Display Data

RS	R/W	DB7	DB6	DB5	DB4	DB3	DB2	DB1	DB0
0	1	D7	D6	D5	D4	D3	D2	D1	D0

Writes data (D0 ~ D7) into the display data RAM.
After writing instruction, Y address is increased by 1 automatically.

7. Read Display Data

RS	R/W	DB7	DB6	DB5	DB4	DB3	DB2	DB1	DB0
1	1	D7	D6	D5	D4	D3	D2	D1	D0

Reads data (D0 ~ D7) from the display data RAM.
After reading instruction, Y address is increased by 1 automatically.

DESCRIPTION OF KS0107 AND KS0108

PLEASE REFER TO DATESHEET OF KS0107 AND KS0108

10. PRECAUTION FOR USING LCM

1. LIQUID CRYSTAL DISPLAY (LCD)

LCD is made up of glass, organic sealant, organic fluid, and polymer based polarizers. The following precautions should be taken when handling,

- (1). Keep the temperature within range of use and storage. Excessive temperature and humidity could cause polarization degradation, polarizer peel off or bubble.
- (2). Do not contact the exposed polarizers with anything harder than an HB pencil lead. To clean dust off the display surface. Wipe gently with cotton. Chamois or other soft material soaked in petroleum benzin.
- (3). Wipe off saliva or water drops immediately. Contact with water over a long period of time may cause polarizer deformation or color fading, while an active LCD with water condensation on its surface will cause corrosion of ITO electrodes.
- (4). Glass can be easily chipped or cracked from rough handling, especially at corners and edges.
- (5). Do not drive LCD with DC voltage.

2. Liquid Crystal Display Modules

2.1 Mechanical Considerations

LCM are assembled and adjusted with a high degree of precision. Avoid excessive shocks and do not make any alterations or modifications. The following should be noted.

- (1). Do not tamper in any way with the tabs on the tabs on the metal frame.
- (2). Do not modify the PCB by drilling extra holes, changing its outline, moving its components or modifying its pattern.
- (3). Do not touch the elastomer connector, especially insert an backlight panel (for example, EL).
- (4). When mounting a LCM make sure that the PCB is not under any stress such as bending or twisting. Elastomer contacts are very delicate and missing pixels could result from slight dislocation of any of the elements.
- (5). Avoid pressing on the metal bezel, otherwise the elastomer connector could be deformed and lose contact, resulting in missing pixels.

2.2. Static Electricity

LCM contains CMOS LSI's and the same precaution for such devices should apply, namely

- (1). The operator should be grounded whenever he/she comes into contact with the module. Never touch any of the conductive parts such as the LSI pads, the copper leads on the PCB and the interface terminals with any parts of the human body.
- (2). The modules should be kept in antistatic bags or other containers resistant to static for storage.

- (3). Only properly grounded soldering irons should be used.

- (4). If an electric screwdriver is used, it should be well grounded and shielded from commutator sparks.

- (5). The normal static prevention measures should be observed for work clothes and working benches; for the latter conductive (rubber) mat is recommended.

- (6). Since dry air is inductive to statics, a relative humidity of 50-60% is recommended.

2.3. Soldering

- (1). Solder only to the I/O terminals.
- (2). Use only soldering irons with proper grounding and no leakage.
- (3). Soldering temperature: $280\text{ }^{\circ}\text{C} \pm 10^{\circ}\text{C}$
- (4). Soldering time: 3 to 4 sec.
- (5). Use eutectic solder with resin flux fill.
- (6). If flux is used, the LCD surface should be covered to avoid flux spatters. Flux residue should be removed afterwards.

2.4. Operation

- (1). The viewing angle can be adjusted by varying the LCD driving voltage V_0 .
- (2). Driving voltage should be kept within specified range; excess voltage shortens display life.
- (3). Response time increases with decrease in temperature.
- (4). Display may turn black or dark blue at temperatures above its operational range; this is (however not pressing on the viewing area) may cause the segments to appear "fractured".
- (5). Mechanical disturbance during operation (such as pressing on the viewing area) may cause the segments to appear "fractured".

2.5. Storage

If any fluid leaks out of a damaged glass cell, wash off any human part that comes into contact with soap and water. Never swallow the fluid. The toxicity is extremely low but caution should be exercised at all the time.

2.6. Limited Warranty

Unless otherwise agreed between EASTERNTRONIC and customer, EASTERNTRONIC will replace or repair any of its LCD and LC, which is found to be defective electrically and visually when inspected in accordance with EASTERNTRONIC acceptance standards, for a period on one year from date of shipment. Confirmation of such date shall be based on freight documents. The warranty liability of EASTERNTRONIC is limited to repair and/or replacement on the terms set forth above. EASTERNTRONIC will not be responsible for any subsequent or consequential events.

11. Declaration of conformity regarding the limitation of dangerous substances

深圳易事通液晶显示模块有限公司SHENZHEN EASTERNTRONIC LCM CO., LTD.

4F, B3 Building, FuYuan Industrial Zone , FuYong Town,

BaoAn District, ShenZhen, P.R.China

DECLARATION OF CONFORMITY REGARDING THE LIMITATION OF DANGEROUS SUBSTANCES

WE , SHENZHEN EASTERNTRONIC LCM CO ., LTD,

Declare that the product of GS12864B-D-BSXTSWW-100 complies with:
The directive 2002/95/EC Dated 2003/01/27 regarding the limitation
of dangerous substances, in particular to clause 4 which forbids
the use of the following elements:

- Lead
- Mercury
- Cadmium
- Hexavalent chromium
- Polybrominated biphenyls
- Polybrominated diphenylethers

And to the annex which points out the exempted implementations

- To the directive 73/23/eec dated 1973/02/19 and the standard
EN60335-1 regarding prohibition of following elements:
- Oils containing polychlorinated biphenyl
 - Asbestos
 - Radioactive substances

Name: Ewing Lau /

SHENZHEN EASTERNTRONIC LCM CO ., LTD.

Issued on November 21, 2007

According with the proposal of Technical Adaption Committee (TAC) of
a limit of 0.1% by weight for lead hexavalent chromium,
mercury, PBBs and PBDRs and 0.01% by weight for Cadmium.