

PRODUCT SPECIFICATIONS

GS12864A-Q-BSXTSWN-100

V1.0

September 5, 2007

 Eastertronic LCD Group

REVISION RECORD

VERSION	DESCRIPTION	DATE
V1.0		September 5, 2007



CONTENTS

SECTIONS	DESCRIPTION	PAGE NO.
1.	LCD Module Numbering System	4
2.	Type Number and Description	5
3.	Mechanical Specifications	6
4.	Electrical Block Diagram	7
	4.1 Pins Definition	
	4.2 Electrical Block Diagram	
5.	Absolute Maximum Ratings	8
	5.1 Electrical Maximum Ratings	
	5.2 Environmental Conditions	
6.	Electrical Specifications	9
	6.1 Electrical Characteristics	
	6.2 Timing Specifications	
7.	Power Supply For LCD Module	10
8.	Electro-Optical Characteristic	11
9.	Instruction Table	13
10.	Precaution for Using LCM	14
11.	Declaration of conformity regarding the limitation of dangerous substances	15

1. LCD Module Numbering System

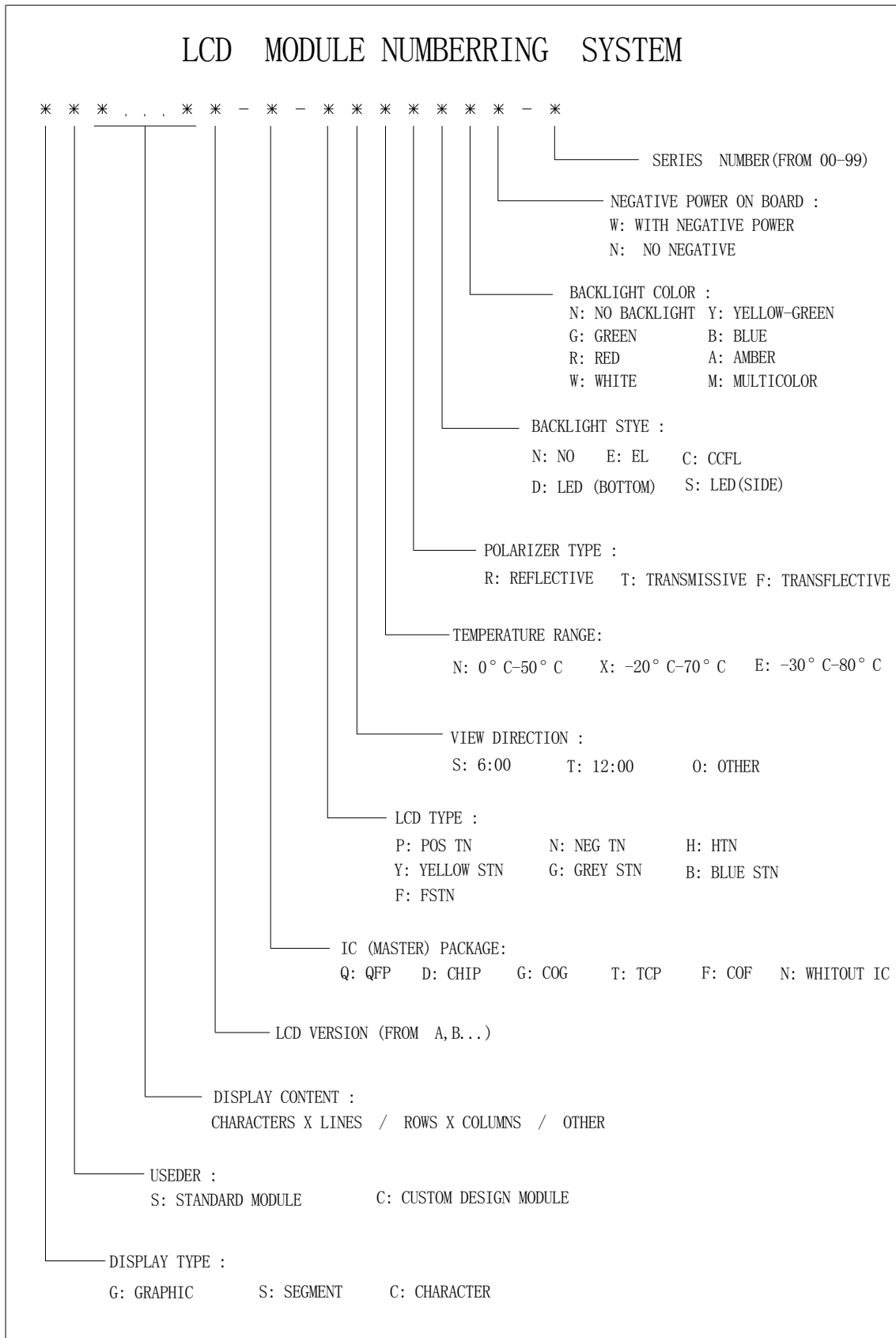

2. TYPE NUMBER AND DESCRIPTION

Type Number	:	GS12864A-Q-BSXTSWN-100
Description	:	128 X 64 DOTS
LCD Panel	:	Blue STN, Negative, Transmissive
Viewing angle	:	6H
Duty	:	1/64
Bias	:	1/9
Logic Voltage	:	5.0V
Operating Temperature	:	-20°C--70°C
Storage Temperature	:	-30°C--80°C
Controller	:	T6963C
Package	:	SMT

3. MECHANICAL SPECIFICATIONS:

ITEM	STANDARD VALUE	UNIT
DISPLAY CONTENT	128 H X 64 V DOTS	
MODULE DIMENSION	78.0 (W) X 70.0 (H) X 13.0(H)	mm
DISPLAY AREA	62.0 (W) X 44.0(H)	mm
DOT SIZE	0.39 (W) X 0.55 (H)	mm
DOT PITCH	0.44 (W) X 0.60 (H)	mm

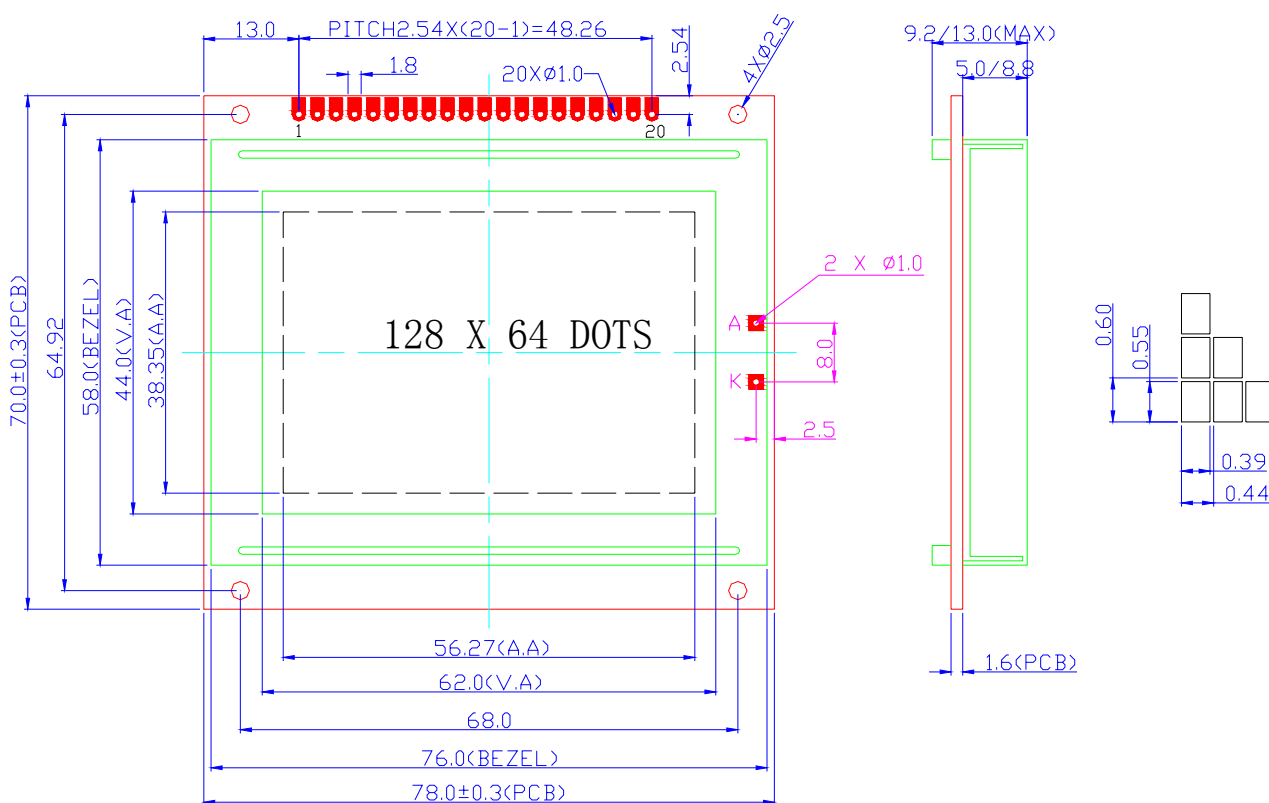

4. ELECTRICAL BLOCK DIAGRAM

4.1 Pin Definition

PIN	SYMBOL	FUNCTION
1	VEE	Negative Voltage Supply(-4.0V)
2	VSS	Power Supply (GND)
3	VDD	Power Supply (+5V)
4	VO	Contrast Adjust
5	R/W	Read or Write (H: Data Appears at Data Bus)
6	RD	Data or Instruction(H: Display Ram Data)
7	CE	Chip Select
8	C/D	L, Data ; H , Command
9	RES	Reset Signal, L Active
10-17	DB0-DB7	Data Bus
18	FS	FONT SELECTION
19	A	Power Supply For BackLight (+)
20	K	Power Supply For BackLight (-)

4.2 Electrical Block Diagram

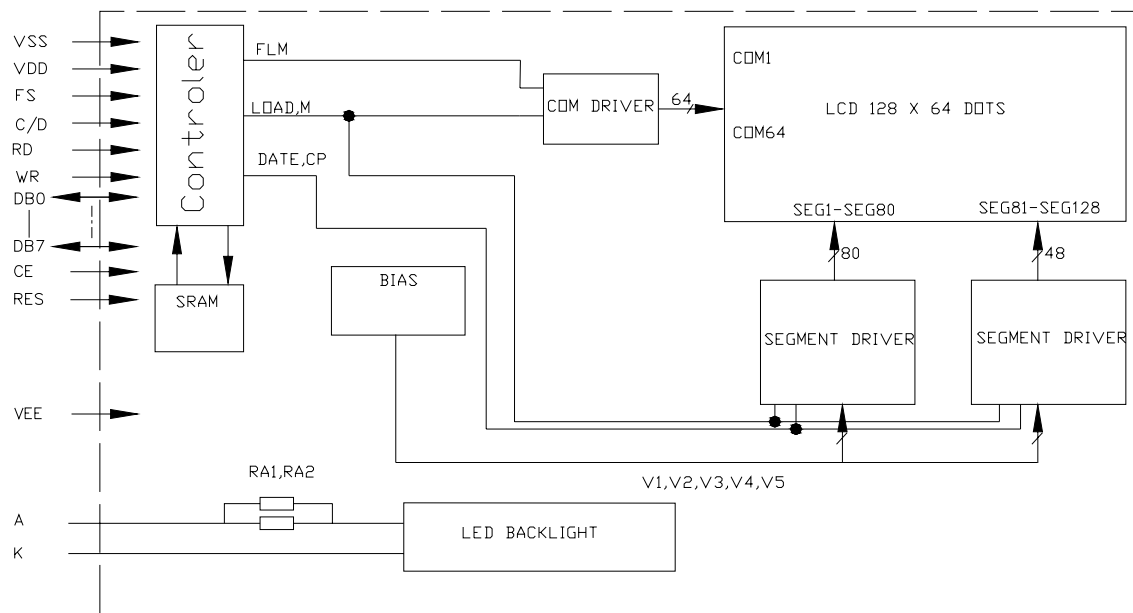

5. ABSOLUTE MAXIMUM RATINGS

5.1 Electrical Maximum Ratings

Characteristic	Symbol	Value	Unit	Note
Operating Voltage	V _{DD}	2.7~5.5V	V	NOTE*1
Supply Voltage	V _{EE}	V _{DD} -19.0~V _{DD} +0.3	V	NOTE*4
Driver Supply Voltage	V _B	-0.3~V _{DD} +0.3	V	NOTE*1,3
	V _{LCD}	V _{EE} -0.3~V _{DD} +0.3	V	NOTE*2
Operating Temperature	T _{OPR}	-20~+70	°C	
Storage Temperature	T _{STG}	-30~+80	°C	

NOTE*1. Based on V_{SS}=0V .

NOTE*2 Applies the same supply voltage to V_{EE1} and V_{EE2}. V_{LCD}=V₀-V_{SS}

NOTE*3 Applies to RSTB,CE,C/D,RD,WR, DB0~DB7.

NOTE*4 Applies to V1,V2,V3,V4,V5.

5.2 Environmental Conditions

ITEM	SYMBOL	CONDITION	MIN	MAX	UNIT
Operating Temp	Topr	-	-20	70	deg C
Storage Temp	Ttsg	-	-30	80	deg C
Humidity Endurance	RH	no condensation Ta</=40 deg	-	95	%
Vibration	-	3 directions	see note (a), page 3		-
Shock	-	3 directions	see note (b), page 3		-

note (a): frequency : varying from 10 Hz in a 1-minute cycle
 amplitude : 1.5mm
 duration : 120 cycles, each lasting 1 minute,
 for each of the 3 directions, x,y,z

note (b): mutually perpendicular directions
 direction normal to surface of LCD glass
 80G, half-sine pulse of duration 11ms
 other 2 directions
 100G, half-sine pulse of duration 11ms

6. ELECTRICAL SPECIFICATIONS

6.1 Electrical Characteristics at Ta=25 deg C, Vdd = 5V + / - 5%

ITEM	SYMBOL	CONDITIO N	MIN	TY P	MA X	UNI T
Supply Voltage (logic)	Vdd-Vss	-	4.5	5.0	5.5	V
Supply Voltage (LCD)	Vdd-V0	Vdd = 5V	--	9.0	9.5	V
Input signal voltage (for E, DB0-7,R/W,RS)	Vih	“H” level	2.4	-	Vdd	V
	Vil	“L” level	0	-	0.6	V
Output voltage for Logic	Voh	-Ioh=0.6mA	Vdd-0.4	-	Vdd	V
	Vol	Iol=1.6mA	0	-	0.4	
Supply Current	Idd	-	--	8.0	10.0	mA
Supply Voltage (LED)	V-bl	-	2.9	3.2	3.4	V
Supply Current (LED)	I-bl	-	-	60	80	mA

6.2 Timing Specifications at Ta = 25 deg C, Vdd = 5V+/-10%, Vss =0V

ITEM	SYMBOL	TEST CONDITIONS	MIN	MAX	UNIT
C/D Set-up Time	t _{CDS}	—	100	—	ns
C/D Hold Time	t _{CDH}	—	10	—	ns
\overline{CE} , \overline{RD} , \overline{WR} Pulse Width	t _{CE} , t _{RD} , t _{WR}	—	80	—	ns
Data Set-up Time	t _{DS}	—	80	—	ns
Data Hold Time	t _{DH}	—	40	—	ns
Access Time	t _{ACC}	—	—	150	ns
Output Hold Time	t _{OH}	—	10	50	ns

6.3 Timing Characteristics

Switching Characteristics (2)

Bus Timing

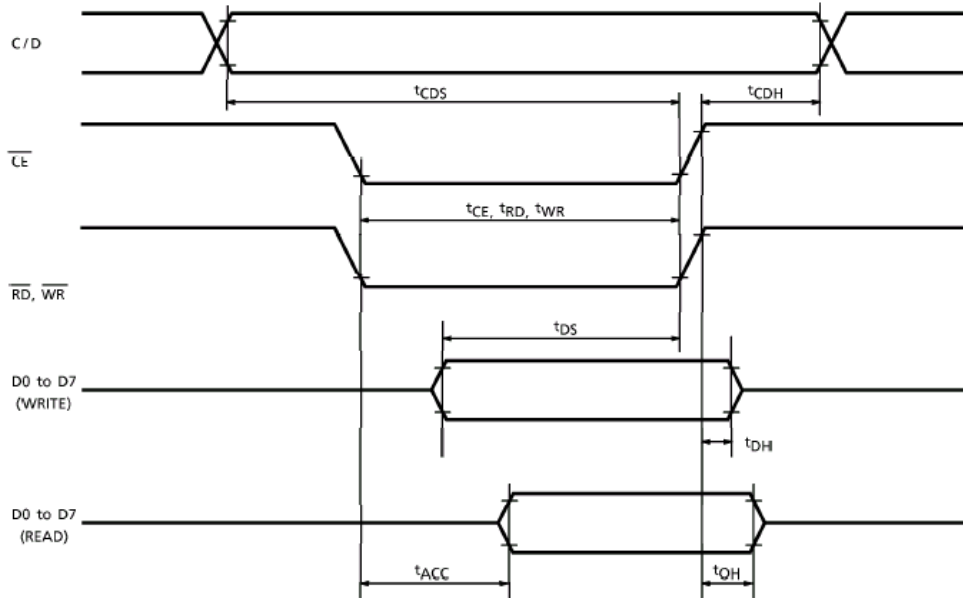

7. POWER SUPPLY FOR LCD MODULE

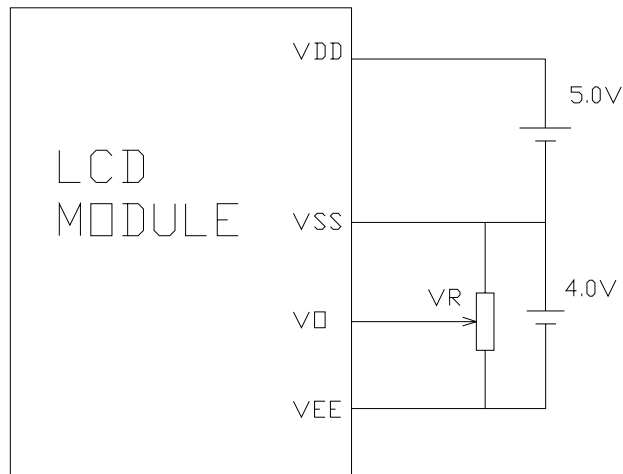

VDD-V0: LCD driving voltage
 VR: 10K-20K

8. ELECTRO-OPTICAL CHARACTERISTIC

ITEM	SYMBOL	CONDITI ON	MIN.	TYP.	MAX.	UNIT	REF.
Contrast	CR	25°C	--	12	--		Note1
Rise Time	tr	25°C	--	160	240	ms	Note2
Fall Time	tf	25°C	--	100	150	ms	note 2
Viewing Angle	$\theta 1 - \theta 2$	25°C	--	--	60	DEG	Note 3
	$\varnothing 1, \varnothing 2$		-40	--	40		
Frame Frequency	Ff	25°C	--	70	--	Hz	note 2

Note(3): Contrast ratio is defined under the following condition:

$$CR = \frac{\text{brightness of non-selected condition}}{\text{brightness of non-selected condition}}$$

- (a). Temperature-----25C
- (b). Frame Frequency-----64Hz
- (c). Viewing angle----- $\theta = 0, \varnothing = 0$
- (d). Operating Voltage---5.0V

Note(1): definition of response time:

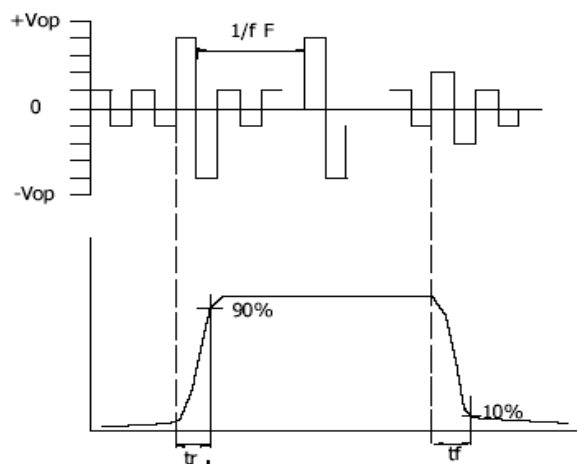

Condition:

- (a). Temperature-----25C
- (b). Frame Frequency-----64Hz
- (c). Viewing angle----- $\theta = 0, \varnothing = 0$
- (d). Operating Voltage---5.0V

Note(2): definition of view angle:

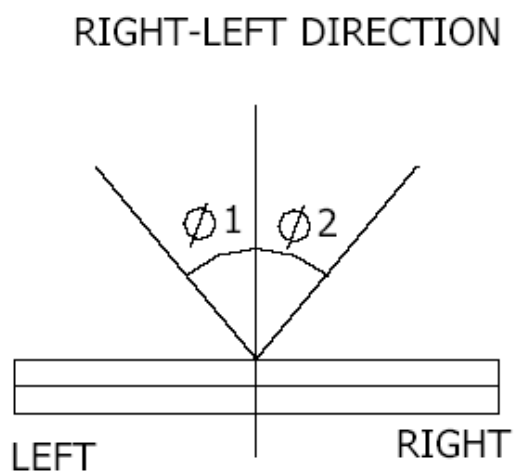
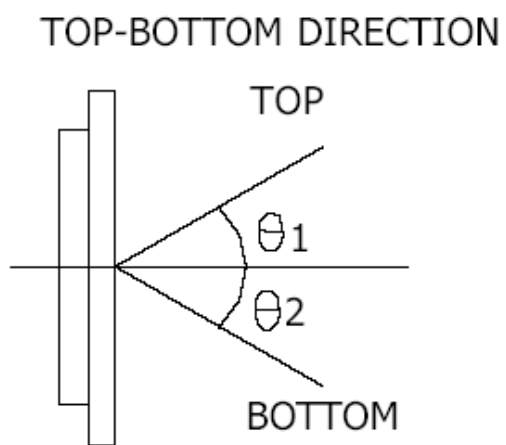

9. INSTRUCTION TABLE

COMMAND	CODE	D1	D2	FUNCTION
REGISTERS SETTING	00100001	X address	Y address	Set Cursor Pointer
	00100010	Data	00H	Set Offset Register
	00100100	Low address	High address	Set Address Pointer
SET CONTROL WORD	01000000	Low address	High address	Set Text Home Address
	01000001	Columns	00H	Set Text Area
	01000010	Low address	High address	Set Graphic Home Address
	01000011	Columns	00H	Set Graphic Area
MODE SET	1000X000	—	—	OR mode
	1000X001	—	—	EXOR mode
	1000X011	—	—	AND mode
	1000X100	—	—	Text Attribute mode
	10000XXX	—	—	Internal CG ROM mode
	10001XXX	—	—	External CG RAM mode
DISPLAY MODE	10010000	—	—	Display off
	1001XX10	—	—	Cursor on, blink off
	1001XX11	—	—	Cursor on, blink on
	100101XX	—	—	Text on, graphic off
	100110XX	—	—	Text off, graphic on
	100111XX	—	—	Text on, graphic on
CURSOR PATTERN SELECT	10100000	—	—	1-line cursor
	10100001	—	—	2-line cursor
	10100010	—	—	3-line cursor
	10100011	—	—	4-line cursor
	10100100	—	—	5-line cursor
	10100101	—	—	6-line cursor
	10100110	—	—	7-line cursor
	10100111	—	—	8-line cursor
DATA AUTO READ / WRITE	10110000	—	—	Set Data Auto Write
	10110001	—	—	Set Data Auto Read
	10110010	—	—	Auto Reset
DATA READ / WRITE	11000000	Data	—	Data Write and Increment ADP
	11000001	—	—	Data Read and Increment ADP
	11000010	Data	—	Data Write and Decrement ADP
	11000011	—	—	Data Read and Decrement ADP
	11000100	Data	—	Data Write and Nonvariable ADP
	11000101	—	—	Data Read and Nonvariable ADP
SCREEN PEEK	11100000	—	—	Screen Peek
SCREEN COPY	11101000			Screen Copy

X : invalid

DESCRIPTION OF T6963C

PLEASE REFER TO DATASHEET OF T6963C

13. Precaution For Using LCM

1. LIQUID CRYSTAL DISPLAY (LCD)

LCD is made up of glass, organic sealant, organic fluid, and polymer based polarizers. The following precautions should be taken when handling,

- (1). Keep the temperature within range of use and storage. Excessive temperature and humidity could cause polarization degradation, polarizer peel off or bubble.
- (2). Do not contact the exposed polarizers with anything harder than an HB pencil lead. To clean dust off the display surface. Wipe gently with cotton. Chamois or other soft material soaked in petroleum benzine.
- (3). Wipe off saliva or water drops immediately. Contact with water over a long period of time may cause polarizer deformation or color fading, while an active LCD with water condensation on its surface will cause corrosion of ITO electrodes.
- (4). Glass can be easily chipped or cracked from rough handling, especially at corners and edges.
- (5). Do not drive LCD with DC voltage.

2. Liquid Crystal Display Modules

2.1 Mechanical Considerations

LCM are assembled and adjusted with a high degree of precision. Avoid excessive shocks and do not make any alterations or modifications. The following should be noted.

- (1). Do not tamper in any way with the tabs on the tabs on the metal frame.
- (2). Do not modify the PCB by drilling extra holes, changing its outline, moving its components or modifying its pattern.
- (3). Do not touch the elastomer connector, especially insert an backlight panel (for example, EL).
- (4). When mounting a LCM make sure that the PCB is not under any stress such as bending or twisting. Elastomer contacts are very delicate and missing pixels could result from slight dislocation of any of the elements.
- (5). Avoid pressing on the metal bezel, otherwise the elastomer connector could be deformed and lose contact, resulting in missing pixels.

2.2. Static Electricity

LCM contains CMOS LSI's and the same precaution for such devices should apply, namely

- (1). The operator should be grounded whenever he/she comes into contact with the module. Never touch any of the conductive parts such as the LSI pads, the copper leads on the PCB and the interface terminals with any parts of the human body.
- (2). The modules should be kept in antistatic bags or

other containers resistant to static for storage.

- (3). Only properly grounded soldering irons should be used.
- (4). If an electric screwdriver is used, it should be well grounded and shielded from commutator sparks.
- (5). The normal static prevention measures should be observed for work clothes and working benches; for the latter conductive (rubber) mat is recommended.
- (6). Since dry air is inductive to statics, a relative humidity of 50-60% is recommended.

2.3. Soldering

- (1). Solder only to the I/O terminals.
- (2). Use only soldering irons with proper grounding and no leakage.
- (3). Soldering temperature: $280\text{ }^{\circ}\text{C} \pm 10^{\circ}\text{C}$
- (4). Soldering time: 3 to 4 sec.
- (5). Use eutectic solder with resin flux fill.
- (6). If flux is used, the LCD surface should be covered to avoid flux spatters. Flux residue should be removed afterwards.

2.4. Operation

- (1). The viewing angle can be adjusted by varying the LCD driving voltage V_0 .
- (2). Driving voltage should be kept within specified range; excess voltage shortens display life.
- (3). Response time increases with decrease in temperature.
- (4). Display may turn black or dark blue at temperatures above its operational range; this is (however not pressing on the viewing area) may cause the segments to appear "fractured".
- (5). Mechanical disturbance during operation (such as pressing on the viewing area) may cause the segments to appear "fractured".

2.5. Storage

If any fluid leaks out of a damaged glass cell, wash off any human part that comes into contact with soap and water. Never swallow the fluid. The toxicity is extremely low but caution should be exercised at all the time.

2.6. Limited Warranty

Unless otherwise agreed between EASTERNTRONIC and customer, EASTERNTRONIC will replace or repair any of its LCD and LC, which is found to be defective electrically and visually when inspected in accordance with EASTERNTRONIC acceptance standards, for a period on one year from date of shipment. Confirmation of such date shall be based on freight documents. The warranty liability of EASTERNTRONIC is limited to repair and/or replacement on the terms set forth above. EASTERNTRONIC will not be responsible for any subsequent or consequential events.

14. Declaration of conformity regarding the limitation of dangerous substances

深圳易事通液晶显示模块有限公司

SHENZHEN EASTERNTRONIC LCM CO., LTD.

4F, B3 Building, FuYuan Industrial Zone, FuYong Town,

BaoAn District, ShenZhen, P.R.China

DECLARATION OF CONFORMITY REGARDING THE LIMITATION OF DANGEROUS SUBSTANCES
--

WE, SHENZHEN EASTERNTRONIC LCM CO., LTD,

Declare that the product of GS12864A-Q-BSXTSWN-100 complies with: The directive 2002/95/EC Dated 2003/01/27 regarding the limitation of dangerous substances, in particular to clause 4 which forbids the use of the following elements:

- Lead
- Mercury
- Cadmium
- Hexavalent chromium
- Polybrominated biphenyls
- Polybrominated diphenylethers

And to the annex which points out the exempted implementations

To the directive 73/23/EEC dated 1973/02/19 and the standard EN60335-1 regarding prohibition of following elements:

- Oils containing polychlorinated biphenyl
- Asbestos
- Radioactive substances

Name: Ewing Liu /

SHENZHEN EASTERNTRONIC LCM CO., LTD.

Issued on September 5, 2007

According with the proposal of Technical Adaption Committee (TAC) of a limit of 0.1% by weight for lead hexavalent chromium, mercury, PBBs and PBDRs and 0.01% by weight for Cadmium.