

# PRODUCT SPECIFICATIONS

GS12232C-D-YTNFDYW-100

V1.0

ShenZhen Easterntronic LCM Co.,Ltd

April 25 ,2006

**REVISION RECORD**

REV	Description	Date
V1.0		April 25,2006

SECTIONS	DESCRIPTION	PAGE NO.
1.	LCD MODULE NUMBERING SYSTEM .....	4
2.	TYPE NUMBER AND DESCRIPTION .....	5
3.	MECHANICAL SPECIFICATIONS .....	6
4.	ELECTRICAL BLOCK DIAGRAM .....	7
	4.1 PIN DEFINITION	
	4.2 ELECTRICAL BLOCK DIAGRAM	
5.	POWER SUPPLY .....	8
6.	ELECTRICAL CHARACTERISTICS .....	9
7.	ABSOLUTE MAXIMUM RATINGS .....	10
8.	TIMING CHARACTERISTICS .....	11
9.	BELECTRO-OPTICAL CHARACTERISTIC .....	13
10.	PRECAUTION FOR USING LCM .....	14

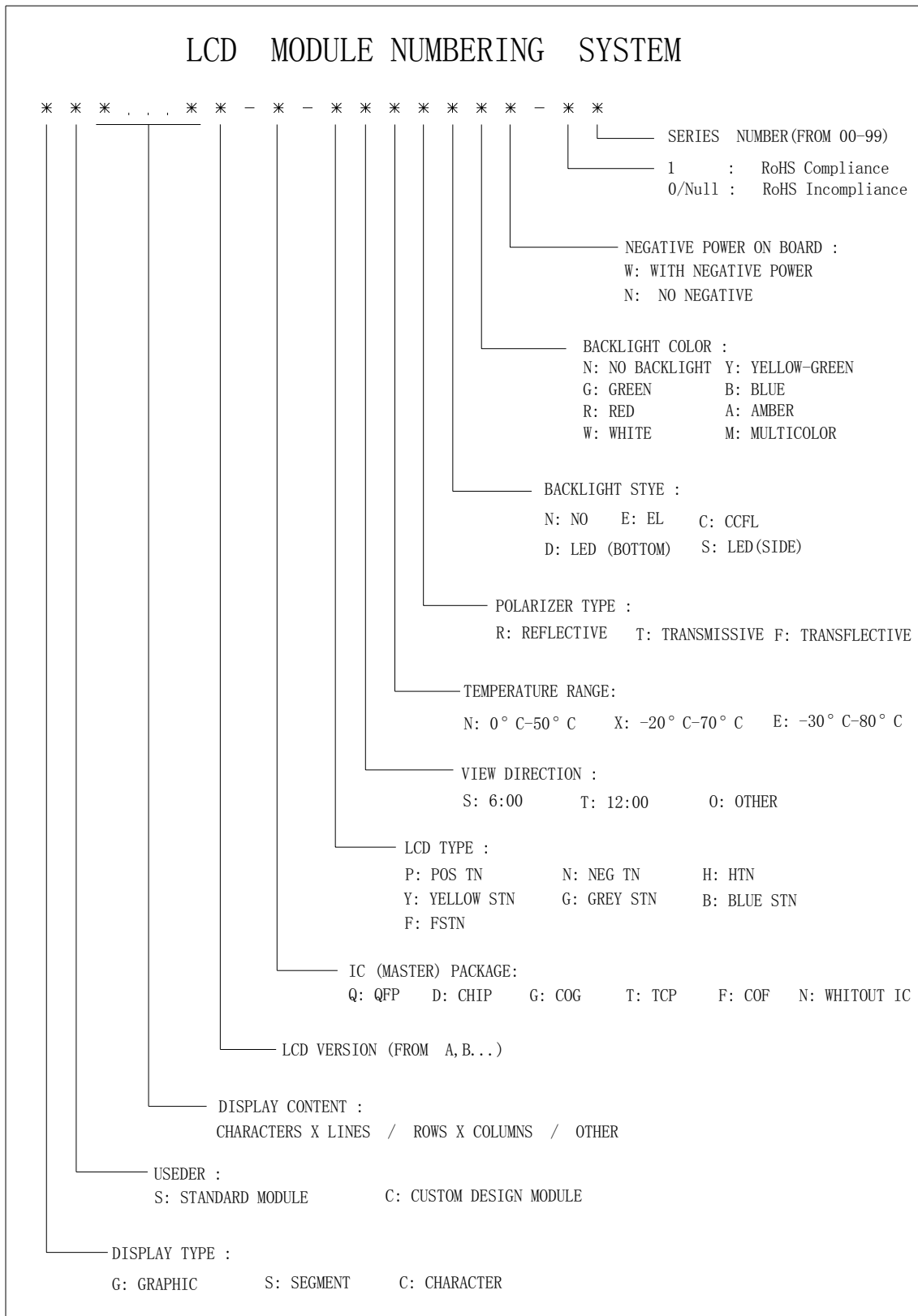

---

## 2. TYPE NUMBER AND DESCRIPTION

Type Number	:	GS12232C-D-YTNFDYW-100
Description	:	122 x 32 DOTS
LCD Panel	:	STN , Yellow-Green
Viewing angle	:	12H
Duty	:	1/32
Bias	:	1/6
Logic Voltage	:	5.0V
Operating Temperature:		0°C--50°C
Storage Temperature	:	-20°C--70°C
Controller	:	SED1520 OR EQU.
Package	:	Bonding
BackLight Mode	:	Bottom
BackLight Color	:	Yellow-Green

## 3. MECHANICAL SPECIFICATIONS:

ITEM	STANDARD VALUE	UNIT
DISPLAY CONTENT	122 (W) x 32 (H) DOTS	
MODULE DIMENSION	98.0 (W) x 60.0 (H) x 13.0(H)	mm
DISPLAY AREA	76.0 (W) x 25.2 (H)	mm
DOT SIZE	0.53 (W) x 0.61 (H)	mm
DOT PITCH	0.57 (W) X 0.65 (H)	mm

## MODLE DIMENSION DRAWING

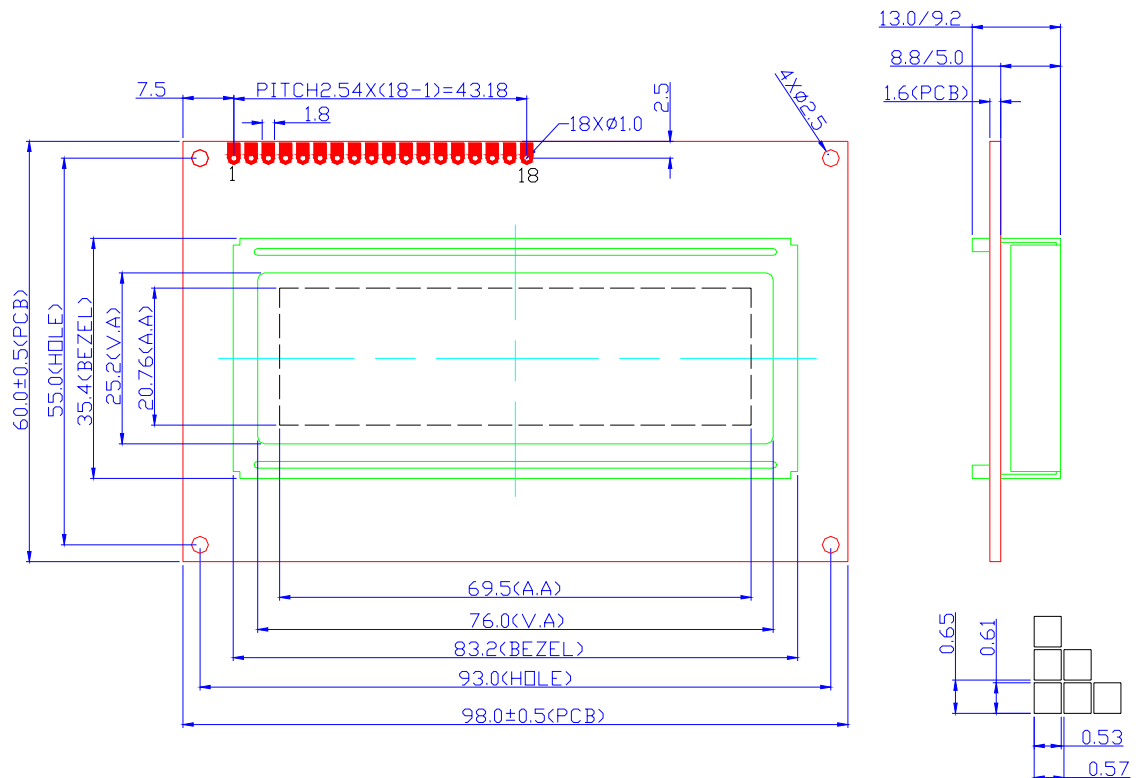

## 4. ELECTRICAL BLOCK DIAGRAM

## 4.1 PIN DEFINITION

Pin No.	Symbol	Level	Funtion
1	VSS	0V	Power Supply
2	VDD	+5.0V	
3	VO	-	Contrast adjust
4	A0	H/L	H: Display Data L: Display control Data
5	E1	H/L	Enable Signal for Left
6	E2	H/L	Enable Signal for Right
7	DB0	H/L	DATA BUS LINE
8	DB1	H/L	
9	DB2	H/L	
10	DB3	H/L	
11	DB4	H/L	
12	DB5	H/L	
13	DB6	H/L	
14	DB7	H/L	
15	A	-	Power Supply for BackLight (+)
16	K	-	Power Supply for BackLight (-)
17	R/W	H/L	Read/Write control
18	RESET	H/L	Reset Signal, Select Intreface

4.2 ELECTRICAL BLOCK DIAGRAM

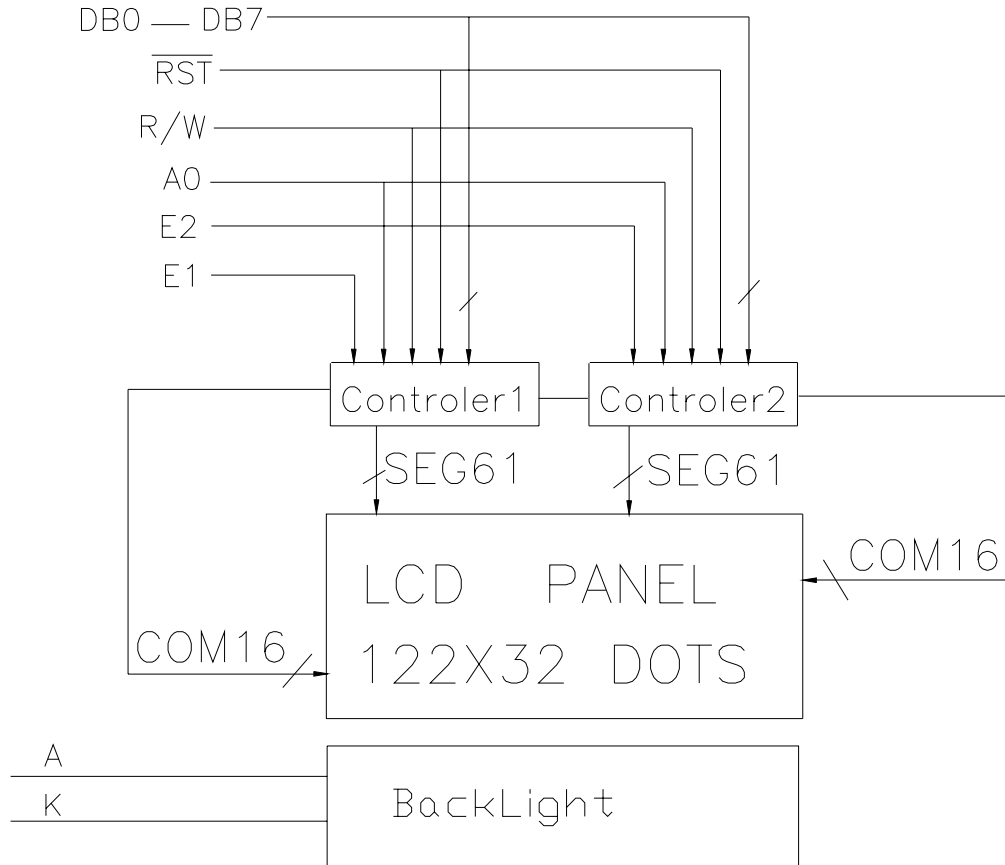

5. POWER SUPPLY

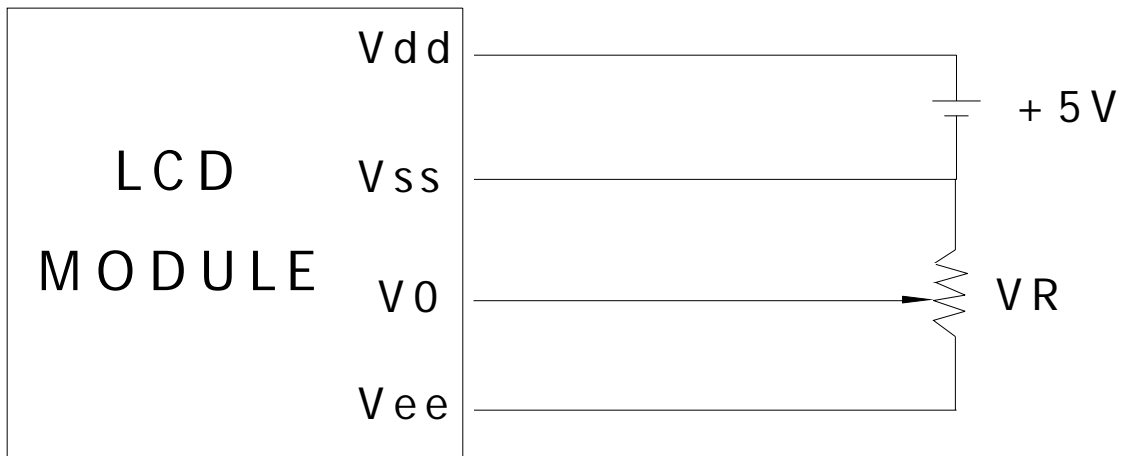

Vdd-V0: LCD Driving Voltage

VR: 10K - 20K



## 6. ELECTRICAL CHARACTERISTICS (at Ta=25°C, Vdd=5.0±5%)

ITEM	SYMBOL	CONDITION	MIN	TYP	MAX	UNIT
Supply Voltage(logic)	VDD-VSS	--	4.5	5.0	5.5	V
Supply Voltage(LCD)	VDD-V0	VDD=5.0V	--	13.5	--	V
Input signal voltage ( for E,DB0-7,R/W,RS)	Vih	“H”level	2.4	--	VDD	V
	Vil	“L”level	0	--	0.6	V
Output voltage for Logic	Voh	-Ioh=0.6mA	VDD-0.4	--	VDD	V
	Vol	Iol=1.6mA	0	--	0.4	V
Supply Current	Idd	--	--	8.0	10.0	mA
BackLight Voltage	A-K	--	3.9	4.1	4.3	V
BackLight Current			--	360	1080	mA

NOTE: LED backlight chips are arranged in two branches of 2 in series

## 7. ABSOLUTE MAXIMUM RATINGS

## 7.1 ELECTRICAL ABSOLUTE RATINGS (VSS=0V)

ITEM	SYMBOL	MIN	MAX	UNIT
Power Supply for LOGIC	VDD-VSS	-0.3	7.0	V
Input Voltage	VI	-0.3	VDD	V
Static Electricity	-	-	-	-

Please Note: LCM should be grounded during handing it.

## 7.2 ENVIRONMENTAL ABSOLUTE MAXIMUM RATINGS

ITEM	Ambient Temperature		Humidity(Without Condensation)	
NORMAL TEMP	OPERATING	MIN	0	NOTE 2, 4
		MAX	50	
	STORAGE	MIN	-20	NOTE 3, 4
		MAX	70	
WIDE TEMP	OPERATING	MIN	-20	NOTE 4, 5
		MAX	70	
	STORAGE	MIN	-30	NOTE 4, 6
		MAX	80	

NOTE 2 Ta≤50°C: 85%RH max

Ta>50°C: Absolute humidity must be lower than the Humidity of 85% RH at 50°C.

- NOTE 3 To at  $-20^{\circ}\text{C}$  will be  $< 48\text{hrs}$ , at  $70^{\circ}\text{C}$  will be  $< 120\text{hrs}$ .
- NOTE 4 Background color changes slightly depending on ambient temperature  
This phenomenon is reversible.
- NOTE 5  $T_a \leq 70^{\circ}\text{C}$  : 75%RH max  
 $T_a > 70^{\circ}\text{C}$ : Absolute humidity must be lower than the  
Humidity of 75% RH at  $70^{\circ}\text{C}$ .
- NOTE 6 To at  $-30^{\circ}\text{C}$  will be  $< 48\text{hrs}$ , at  $80^{\circ}\text{C}$  will be  $< 120\text{hrs}$ .

## 8. TIMING CHARACTERISTICS

### AC Characteristics

- MPU Bus Read/Write i (80-family MPU)

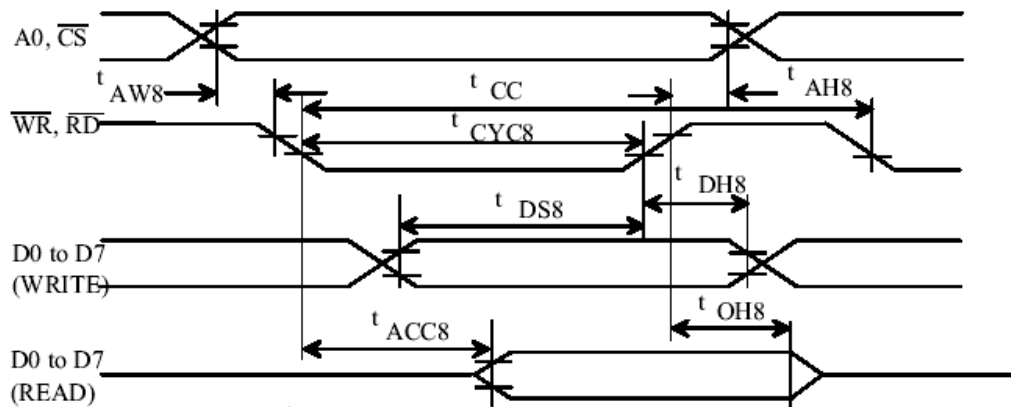

$T_a = -20$  to  $75$  deg. C,  $V_{SS} = -1.0 \pm 10\%$  unless stated otherwise

Parameter	Symbol	Condition	Rating		Unit	Signal
			min	max		
Address hold time	tAH8		10	--	ns	A0, CS
Address setup time	tAW8		20	--	ns	
System cycle time	tCYC8		1,000	--	ns	WR, RD
Control pulsewidth	tcc		200	--	ns	
Data setup time	tDS8		80	--	ns	DO to D7
Data hold time	tDH8		10	--	ns	
RD access time	tACC8		--	90	ns	
Output disable time	tCH8	CL= 100pF	10	60	ns	

Notes : 1. Increase parameter values by 200% when  $V_{SS} = -3.0\text{V}$ .

2. All inputs must have a rise and fall time of less than 15 ns.

• MPU Bus Read/Write II (68-family MPU)

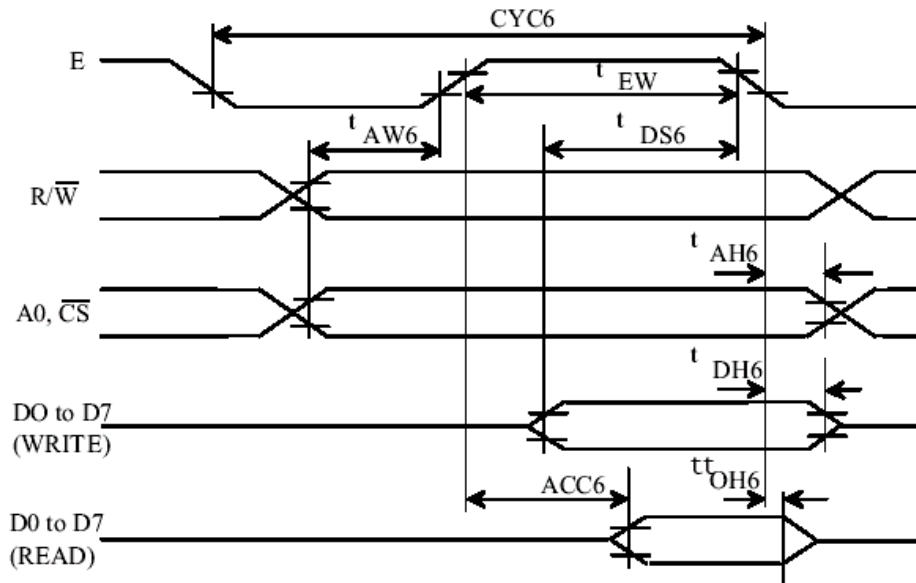

Ta= -20 to 75 deg. C. Vss= -5V  $\pm$  10 unless stated otherwise

Parameter	Symbol	Condition	Rating		Unit	Signal
			min	max		
System cycle time	tCYC6		1,000	--	ns	A0, $\overline{CS}$ , R/ $\overline{W}$
Address setup time	tAW6		20	--	ns	
Address hold time	tAH6		10	--	ns	
Data setup time	tDS6		80	--	ns	D0 to D7
Data hold time	tDH6		10	--	ns	
Output disable time	tOH6		10	60	ns	
Access time	tACC6	CL= 100pF	--	90	ns	
Enable pulsewidth	Read	tEW	100	--	ns	E
	Write		8	--	ns	

Notes : 1. tCYC6 is the cycle time of CS. E=H. not the cycle time of E.

2. Increase parameter values by 200% when Vss= -3.0V.

3. all inputs must have a rise and fall time of less than 15 ns.

## 9. BELECTRO-OPTICAL CHARACTERISTIC

ITEM	SYMBOL	CONDITI ON	MIN.	TYP.	MAX.	UNIT	REF.
Contrast	CR	25°C	--	12	--		Note1
Rise Time	tr	25°C	--	160	240	ms	Note2
Fall Time	tf	25°C	--	100	150	ms	note 2
Viewing Angle	$\theta_1 - \theta_2$	25°C	--	--	60	DEG	Note 3
	$\phi_1, \phi_2$		-40	--	40		
Frame Frequency	Ff	25°C	--	70	--	Hz	note 2

**Note(3): Contrast ratio is defined under the following condition:**

CR =  $\frac{\text{brightness of non-selected condition}}{\text{brightness of non-selected condition}}$

- Temperature-----25C
- Frame Frequency-----64Hz
- Viewing angle-----  $\theta = 0, \phi = 0$
- Operating Voltage---5.0V

**Note(1): definition of response time:**

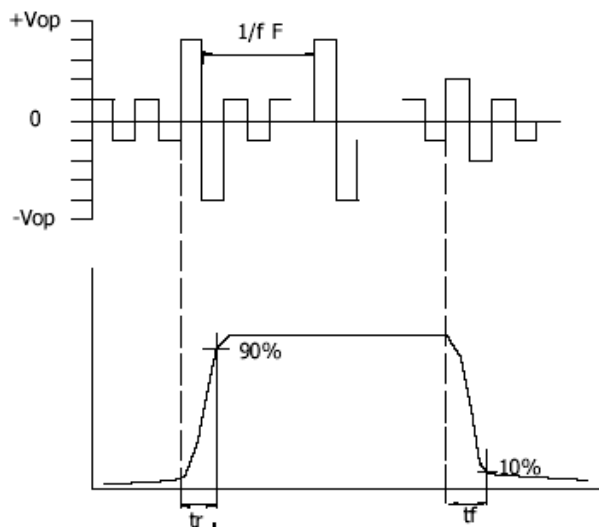

**Condition:**

- Temperature-----25C
- Frame Frequency-----64Hz
- Viewing angle-----  $\theta = 0, \phi = 0$
- Operating Voltage---5.0V

**Note(2): definition of view angle:**

TOP-BOTTOM DIRECTION

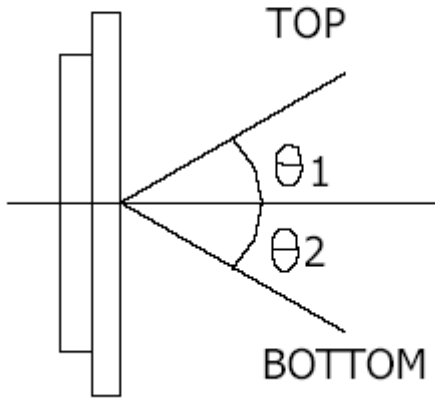

RIGHT-LEFT DIRECTION

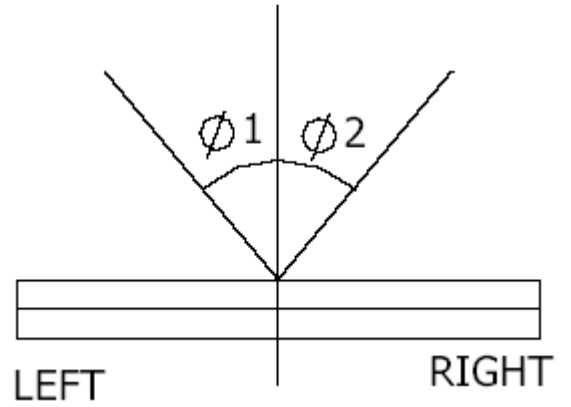

**10. PRECAUTION FOR USING LCM****1. LIQUID CRYSTAL DISPLAY (LCD)**

LCD is made up of glass, organic sealant, organic fluid, and polymer based polarizers. The following precautions should be taken when handling,

- (1). Keep the temperature within range of use and storage. Excessive temperature and humidity could cause polarization degradation, polarizer peel off or bubble.
- (2). Do not contact the exposed polarizers with anything harder than an HB pencil lead. To clean dust off the display surface. Wipe gently with cotton. Chamois or other soft material soaked in petroleum benzine.
- (3). Wipe off saliva or water drops immediately. Contact with water over a long period of time may cause polarizer deformation or color fading, while an active LCD with water condensation on its surface will cause corrosion of ITO electrodes.
- (4). Glass can be easily chipped or cracked from fill. rough handling, especially at corners and edges.
- (5). Do not drive LCD with DC voltage.

**2. Liquid Crystal Display Modules****2.1 Mechanical Considerations**

LCM are assembled and adjusted with a high degree of precision. Avoid excessive shocks and do not make any alterations or modifications. The following should be noted.

- (1). Do not tamper in any way with the tabs on the tabs on the metal frame.
- (2). Do not modify the PCB by drilling extra holes, changing its outline, moving its components or modifying its pattern.
- (3). Do not touch the elastomer connector, especially insert a backlight panel (for example, EL).
- (4). When mounting a LCM make sure that the PCB is not under any stress such as bending or twisting. Elastomer contacts are very delicate and missing pixels could result from slight dislocation of any of the elements.
- (5). Avoid pressing on the metal bezel, otherwise the elastomer connector could be deformed and lose contact, resulting in missing pixels.

**2.2. Static Electricity**

LCM contains CMOS LSI's and the same precaution for such devices should apply, namely

- (1). The operator should be grounded whenever he/she comes into contact with the module. Never touch any of the conductive parts such as the LSI pads, the copper leads on the PCB and the interface terminals with any parts of the human body.
- (2). The modules should be kept in antistatic bags or other containers resistant to static

for storage.

- (3). Only properly grounded soldering irons should be used.
- (4). If an electric screwdriver is used, it should be well grounded and shielded from commutator sparks.
- (5). The normal static prevention measures should be observed for work clothes and working benches; for the latter conductive (rubber) mat is recommended.
- (6). Since dry air is inductive to statics, a relative humidity of 50-60% is recommended.

**2.3. Soldering**

- (1). Solder only to the I/O terminals.
- (2). Use only soldering irons with proper grounding and no leakage.
- (3). Soldering temperature:  $280\text{ }^{\circ}\text{C} \pm 10^{\circ}\text{C}$
- (4). Soldering time: 3 to 4 sec.
- (5). Use eutectic solder with resin flux
- (6). If flux is used, the LCD surface should be covered to avoid flux spatters. Flux residue should be removed afterwards.

**2.4. Operation**

- (1). The viewing angle can be adjusted by varying the LCD driving voltage  $V_0$ .
- (2). Driving voltage should be kept within specified range; excess voltage shortens display life.
- (3). Response time increases with decrease in temperature.
- (4). Display may turn black or dark blue at temperatures above its operational range; this is (however not pressing on the viewing area) may cause the segments to appear "fractured".
- (5). Mechanical disturbance during operation (such as pressing on the viewing area) may cause the segments to appear "fractured".

**2.5. Storage**

If any fluid leaks out of a damaged glass cell, wash off any human part that comes into contact with soap and water. Never swallow the fluid. The toxicity is extremely low but caution should be exercised at all the time.

**2.6. Limited Warranty**

Unless otherwise agreed between EASTERNTRONIC and customer, EASTERNTRONIC will replace or repair any of its LCD and LC, which is found to be defective electrically and visually when inspected in accordance with EASTERNTRONIC acceptance standards, for a period of one year from date of shipment. Confirmation of such date shall be based on freight documents. The warranty liability of EASTERNTRONIC is limited to repair and/or replacement on the terms set forth above. EASTERNTRONIC will not be responsible for any subsequent or consequential events.

Declaration of conformity regarding the limitation of dangerous substances

## 深圳易事通液晶显示模块有限公司

SHENZHEN EASTERNTRONIC LCM CO., LTD.

4F, B3 Building, FuYuan Industrial Zone, FuYong Town,

BaoAn District, ShenZhen, P.R. China

DECLARATION OF CONFORMITY REGARDING THE LIMITATION OF DANGEROUS SUBSTANCES

WE, SHENZHEN EASTERNTRONIC LCM CO., LTD,

Declare that the product of GS12232C-D-YTNFDYW-100 complies with:  
The directive 2002/95/EC Dated 2003/01/27 regarding the limitation  
of dangerous substances, in particular to clause 4 which forbids  
the use of the following elements:

- Lead
- Mercury
- Cadmium
- Hexavalent chromium
- Polybrominated biphenyls
- Polybrominated diphenylethers

And to the annex which points out the exempted implementations

To the directive 73/23/EEC dated 1973/02/19 and the standard  
EN60335-1 regarding prohibition of following elements:

- Oils containing polychlorinated biphenyl
- Asbestos
- Radioactive substances

Name: Ewing Liu /

SHENZHEN EASTERNTRONIC LCM CO., LTD.

Issued on April 25, 2006

According with the proposal of Technical Adaption Committee(TAC) of a limit of 0.1% by weight for lead hexavalent

chromium, mercury, PBBs and PBDRs and 0.01% by weight for Cadmium