

PRODUCT SPECIFICATION

GS12232C-D-BTXTSWW-110

V1.0

June 4, 2009

 Eastertronic LCD Group

REVISION RECORD

REV	Description	Date
V1.0	First issue	May 30, 2009

CONTENTS

SECTIONS	DESCRIPTION	PAGE NO.
1.	LCD Module Numbering System	4
2.	Type Number and Description	5
3.	Mechanical Specifications	6
4.	Electrical Block Diagram	7
4.1	Pins Definition	
4.2	Electrical Block Diagram	
5.	Absolute Maximum Ratings	8
5.1	Electrical Maximum Ratings	
5.2	Environmental Conditions	
6.	Electrical Specifications	9
6.1	Electrical Characteristics	
6.2	Timing Specifications	
7.	Power Supply For LCD Module	10
8.	Electro-Optical Characteristic	11
9.	Instruction Table	13
10.	Precaution for Using LCM	14
11.	Quality units	15
12.	Declaration of conformity regarding the limitation of dangerous substances	26

1. LCD Module Numbering System

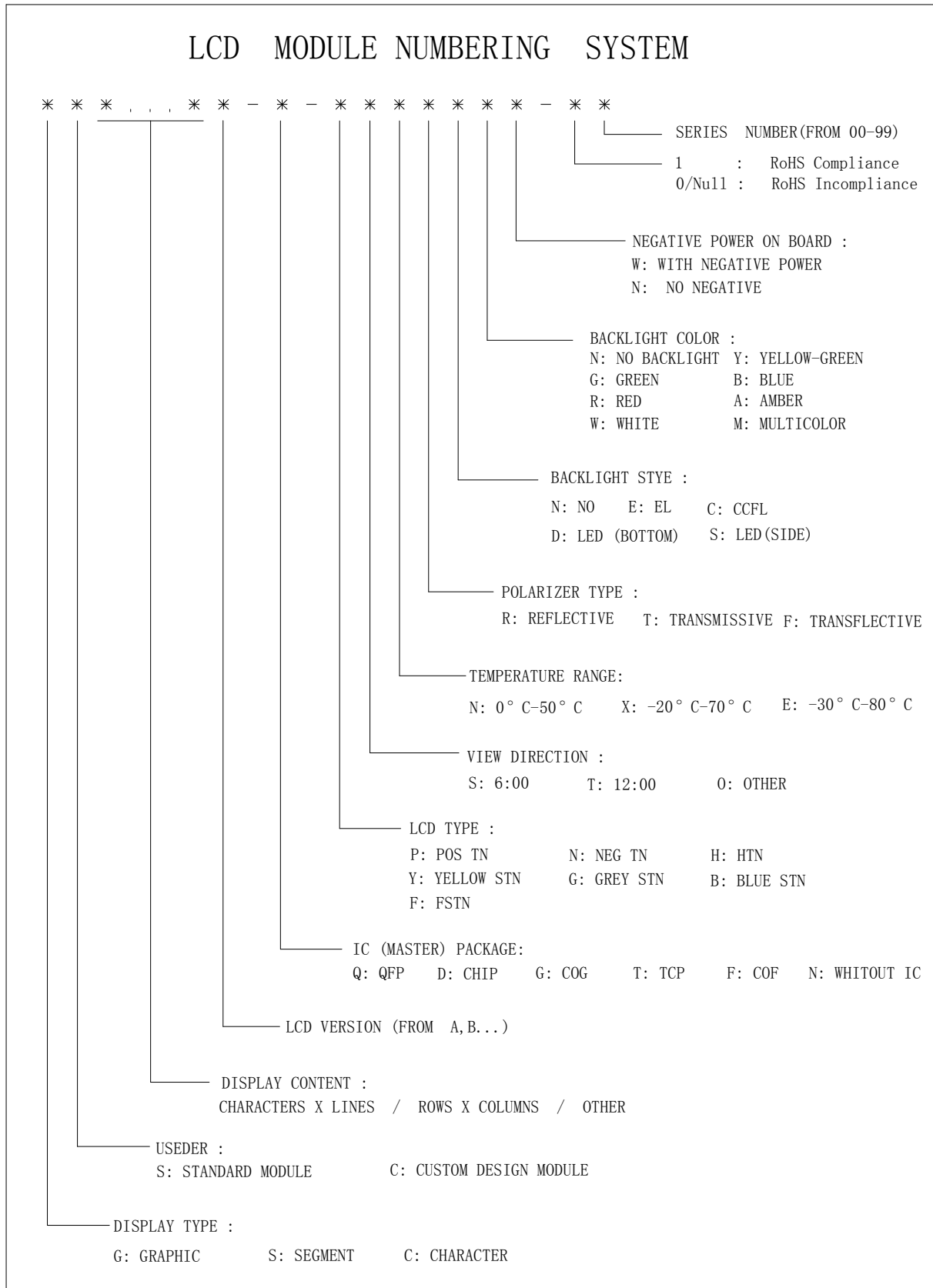

2. Type Number And Description

Type Number	:	GS12232C-D-BTXTSWW-110
Description	:	122 x 32 DOTS
LCD Panel	:	Blue STN, Negative, Transmissive
Viewing angle	:	12H
Duty	:	1/32
Bias	:	1/6
Logic Voltage	:	5.0V
Operating Temperature	:	-20°C--70°C
Storage Temperature	:	-30°C--80°C
Controller	:	SB1661G-M18 OR EQU.
Package	:	Bonding
BackLight Mode	:	Side, White LED

3. MECHANICAL SPECIFICATIONS:

ITEM	STANDARD VALUE	UNIT
DISPLAY CONTENT	122 (W) x 32 (H) DOTS	
MODULE DIMENSION	98.0 (W) x 60.0 (H) x 13.0(H)	mm
DISPLAY AREA	76.0 (W) x 25.2 (H)	mm
DOT SIZE	0.53 (W) x 0.61 (H)	mm
DOT PITCH	0.57 (W) X 0.65 (H)	mm

MODLE DIMENSION DRAWING

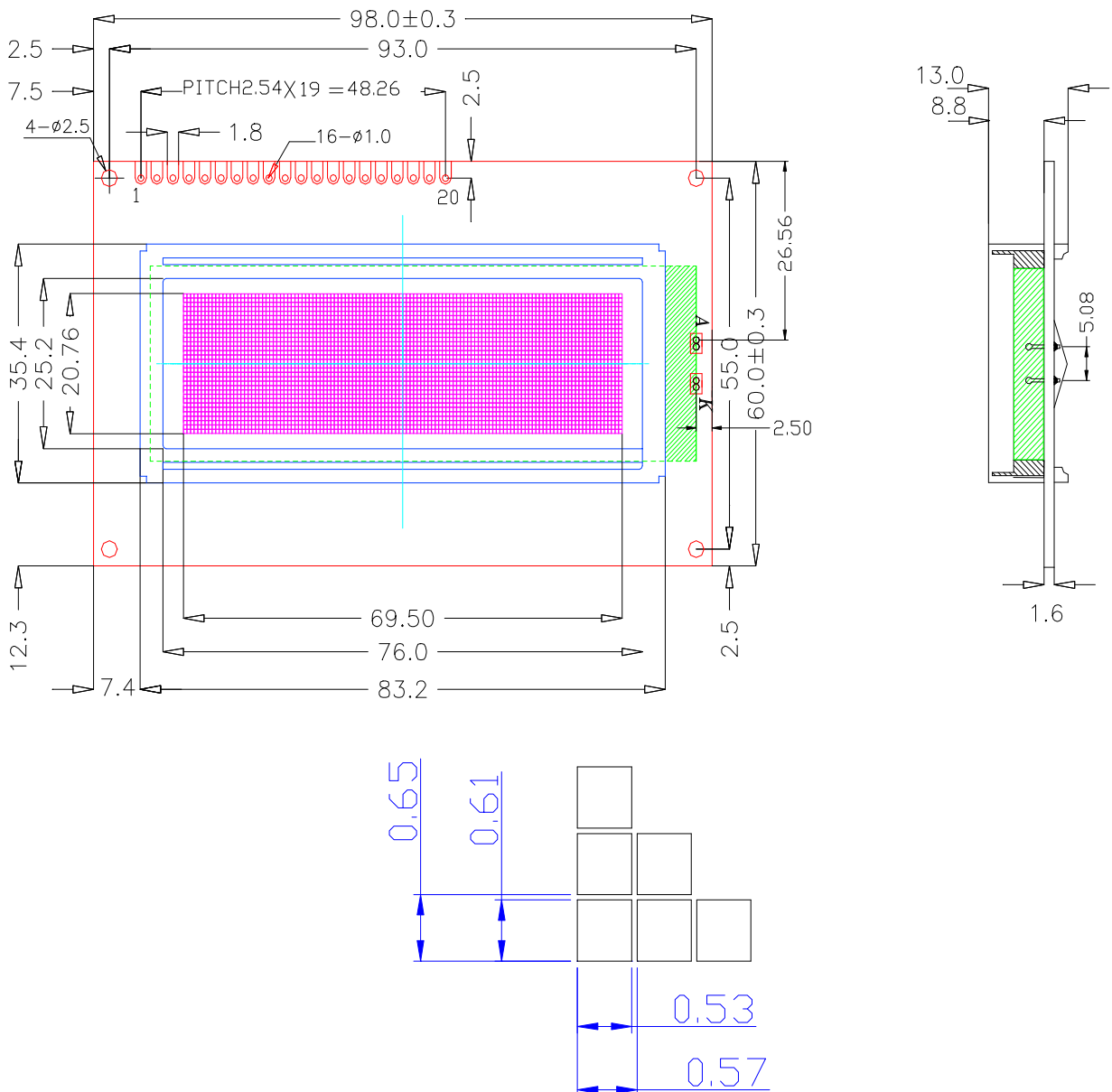

* Remark : non-specified tolerance refers this model. (±0.2mm)

4. ELECTRICAL BLOCK DIAGRAM

4.1 PIN DEFINITION

Pin No.	Symbol	Level	Function
1	VSS	0V	Power Supply
2	VDD	+5.0V	
3	VO	-	Contrast adjust
4	A0	H/L	H: Display Data L: Display control Data
5	E1	H/L	Enable Signal for Left
6	E2	H/L	Enable Signal for Right
7-14	DB0-DB7	H/L	DATA BUS LINE
15	A	-	Power Supply for BackLight (+)
16	K	-	Power Supply for BackLight (-)
17	R/W	H/L	Read/Write control
18	RESET	H/L	Reset Signal, Select Intreface
19	A	-	Power Supply for BackLight (+)
20	K	-	Power Supply for BackLight (-)

4.2 ELECTRICAL BLOCK DIAGRAM

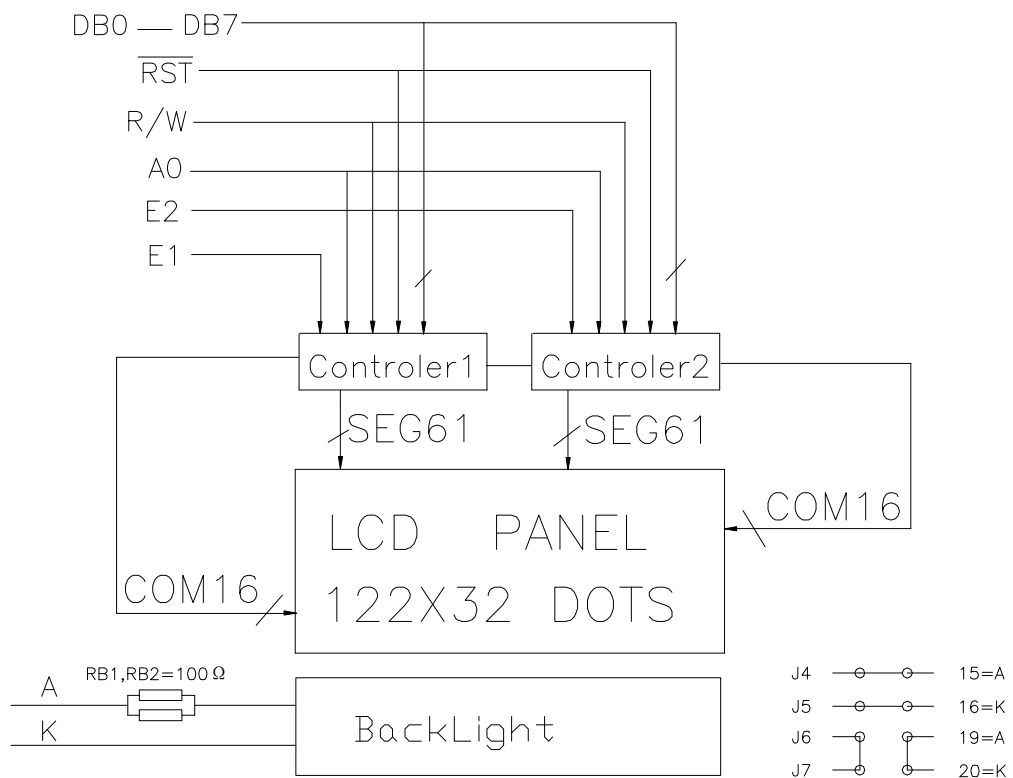

5. ABSOLUTE MAXIMUM RATINGS

5.1 ELECTRICAL ABSOLUTE RATINGS (VSS=0V)

ITEM	SYMBOL	MIN	MAX	UNIT
Power Supply for LOGIC	VDD-VSS	-0.3	7.0	V
Input Voltage	VI	-0.3	VDD	V
Static Electricity	-	-	-	-

Please Note: LCM should be grounded during handling it.

5.2 ENVIRONMENTAL ABSOLUTE MAXIMUM RATINGS

ITEM	Ambient Temperature		Humidity(Without Condensation)	
NORMAL TEMP	OPERATING	MIN	0	NOTE 2, 4
		MAX	50	
	STORAGE	MIN	-20	NOTE 3, 4
		MAX	70	
WIDE TEMP	OPERATING	MIN	-20	NOTE 4, 5
		MAX	70	
	STORAGE	MIN	-30	NOTE 4, 6
		MAX	80	

NOTE 2 $T_a \leq 50^\circ\text{C}$: 85%RH max

$T_a > 50^\circ\text{C}$: Absolute humidity must be lower than the Humidity of 85% RH at 50°C .

NOTE 3 T_o at -20°C will be < 48hrs, at 70°C will be < 120hrs.

NOTE 4 Background color changes slightly depending on ambient temperature. This phenomenon is reversible.

NOTE 5 $T_a \leq 70^\circ\text{C}$: 75%RH max

$T_a > 70^\circ\text{C}$: Absolute humidity must be lower than the Humidity of 75% RH at 70°C .

NOTE 6 T_o at -30°C will be < 48hrs, at 80°C will be < 120hrs.

6. ELECTRICAL CHARACTERISTICS (at Ta=25°C, Vdd=5.0±5%)

6.1 Electrical Characteristics at Ta=25 deg C, Vdd = 5V +/- 5%

ITEM	SYMBOL	CONDITIO N	MIN	TYP	MAX	UN IT
Supply Voltage(logic)	VDD-VS S	--	4.5	5.0	5.5	V
Supply Voltage(LCD)	VDD-V0	VDD=5.0V	13.0	13.5	14.0	V
Input signal voltage (for E,DB0-7,R/W,RS)	Vih	“H”level	2.4	--	VDD	V
	Vil	“L”level	0	--	0.6	V
OutOutput voltage for Logic	Voh	-Ioh=0.6mA	VDD -0.4	--	VDD	V
	Vol	Iol=1.6mA	0	--	0.4	V
Supply Current	Idd	--	--	8.0	10.0	mA
BackLight Voltage	A-K	--	2.9	3.1	3.3	V
BackLight Current	If	--	--	45	60	mA
*Peak forward current(B/L)	I _{fp}	1 msec pulse 10% Duty Cycle	-	-	180	mA
*Power dissipation(B/L)	Pd	--	-	-	186	mW

*For operation above 25°C, the If, I_{fp}&Pd must be derated, the current derating is -1.08mA/°C for DC drive and -2.58mA/°C for pulse drive,the power dissipation is -3.348 mW /°C.The Blacklight working current must not more than 60% of the Ifmax or I_{fp}max according to the working temperature

6.2 TIMING CHARACTERISTICS

AC Characteristics

- MPU Bus Read/Write i (80-family MPU)

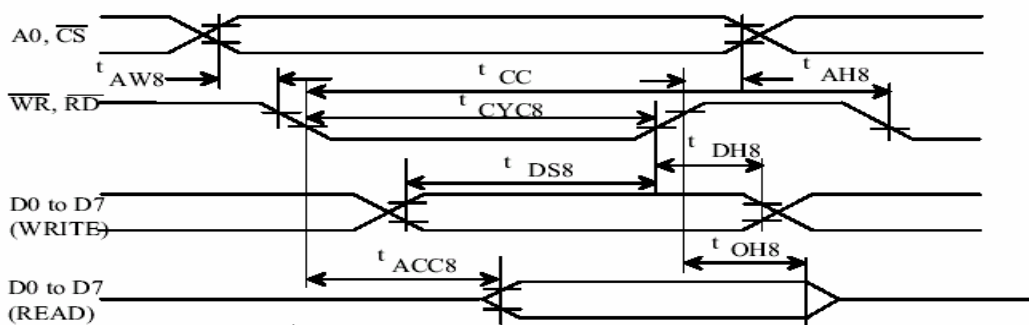

Ta= -20 to 75 deg. C, Vss= -1.0± 10% unless stated otherwise

Parameter	Symbol	Condition	Rating		Unit	Signal
			min	max		
Address hold time	tAH8		10	--	ns	A0, CS
Address setup time	tAW8		20	--	ns	
System cycle time	tCYC8		1,000	--	ns	WR, RD
Control pulsewidth	tcc		200	--	ns	
Data setup time	tDS8		80	--	ns	DO to D7
Data hold time	tDH8		10	--	ns	
RD access time	tACC8		--	90	ns	
Output disable time	tCH8	CL= 100pF	10	60	ns	

Notes : 1. Increase parameter values by 200% when Vss= -3.0V.

2. All inputs must have a rise and fall time of less than 15 ns.

• MPU Bus Read/Write II (68-family MPU)

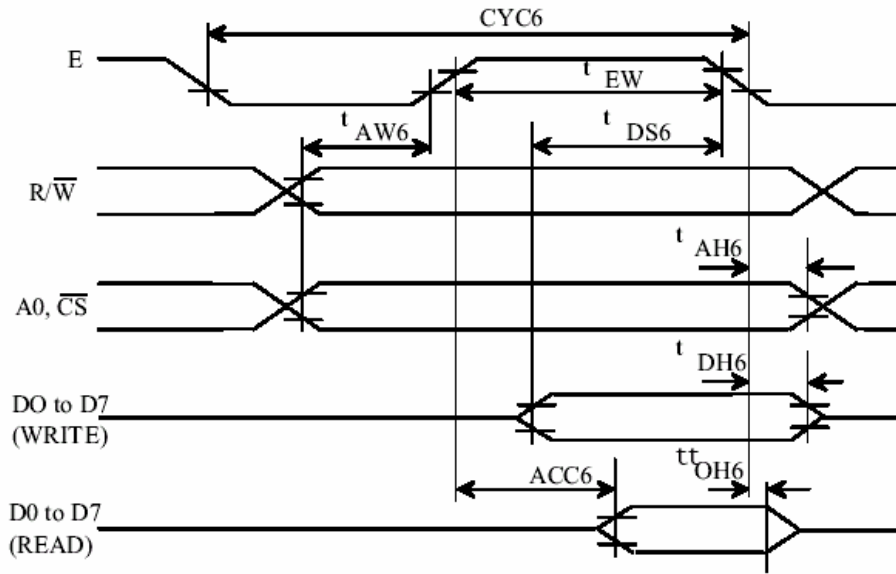

Ta= -20 to 75 deg. C. Vss= -5V ± 10 unless stated otherwise

Parameter	Symbol	Condition	Rating		Unit	Signal
			min	max		
System cycle time	tCYC6		1,000	--	ns	A0, \overline{CS} , R/ \overline{W}
Address setup time	tAW6		20	--	ns	
Address hold time	tAH6		10	--	ns	
Data setup time	tDS6		80	--	ns	D0 to D7
Data hold time	tDH6		10	--	ns	
Output disable time	tOH6		10	60	ns	
Access time	tACC6	CL= 100pF	--	90	ns	
Enable pulsewidth	tEW	Read	100	--	ns	
		Write	8	--	ns	

- Notes : 1. tCYC6 is the cycle time of CS. E=H. not the cycle time of E.
 2. Increase parameter values by 200% when Vss= -3.0V.
 3. all inputs must have a rise and fall time of less than 15 ns.

7. Power Supply For LCD Module

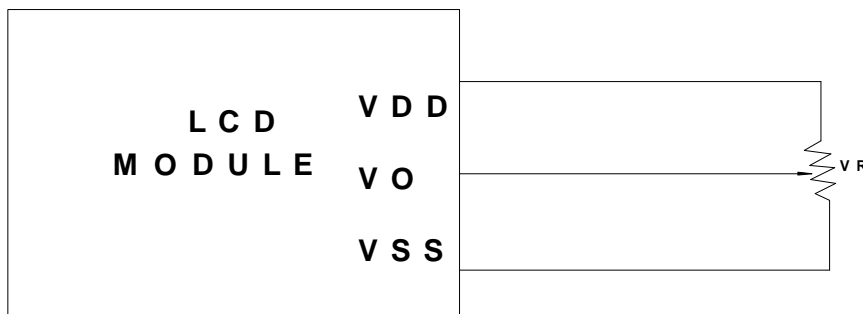

VLCD-VO: LCD DRIVING VOLTAGE
 VR: 10K-20K

8. BELECTRO-OPTICAL CHARACTERISTIC

ITEM	SYMBOL	CONDITI ON	MIN.	TYP.	MAX.	UNIT	REF.
Contrast	CR	25°C	--	12	--		Note1
Rise Time	tr	25°C	--	160	240	ms	Note2
Fall Time	tf	25°C	--	100	150	ms	note 2
Viewing Angle	$\theta_1 - \theta_2$	25°C	--	--	60	DEG	Note 3
	ϕ_1, ϕ_2		-40	--	40		
Frame Frequency	Ff	25°C	--	70	--	Hz	note 2

Note(3): Contrast ratio is defined under the following condition:

$$CR = \frac{\text{brightness of non-selected condition}}{\text{brightness of non-selected condition}}$$

- Temperature-----25C
- Frame Frequency-----64Hz
- Viewing angle----- $\theta = 0, \phi = 0$
- Operating Voltage---5.0V

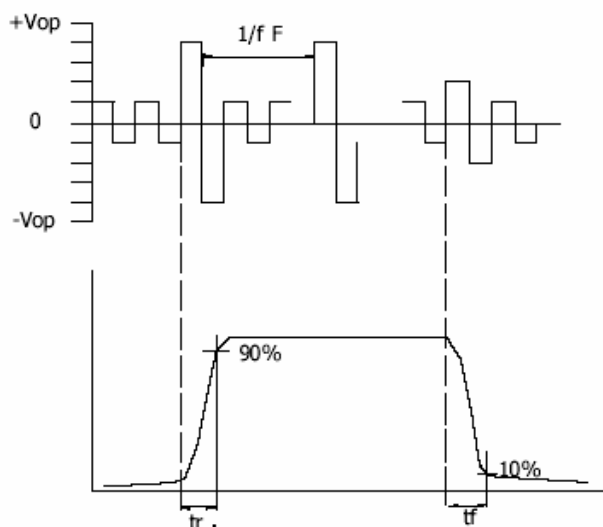
Note(1): definition of response time:**Condition:**

- Temperature-----25C
- Frame Frequency-----64Hz
- Viewing angle----- $\theta = 0, \phi = 0$
- Operating Voltage---5.0V

Note(2): definition of view angle:

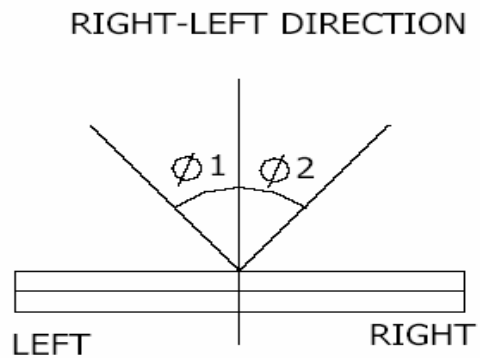
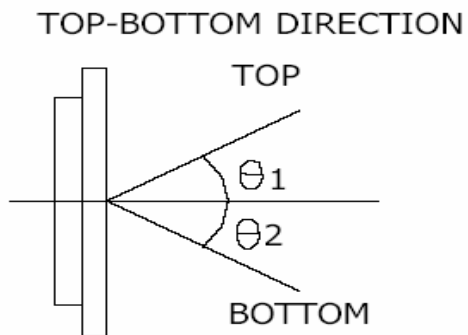

9. INSTRUCTION TABLE

Command	Code											Function
	A0	\overline{RD}	\overline{WR}	D7	D6	D5	D4	D3	D2	D1	D0	
Display On/Off	0	1	0	1	0	1	0	1	1	1	0/1	Turns display on or off. 1 : ON, 0 : OFF
Display start line	0	1	0	1	1	0	Display start address (0 to 31)					Specifies RAM line corresponding to top line of display.
Set page address	0	1	0	1	0	1	1	1	0	Page (0 to 3)		Sets display RAM page in page address register.
Set column (segment) address	0	1	0	0	Column address (0 to 79)							Sets display RAM column address in column address register.
Read status	0	0	1	Busy	ADC	ON/OFF	Reset	0	0	0	0	Reads the following status : BUSY 1 : Busy 0 : Ready ADC 1 : CW output 0 : CCW output ON/OFF 1 : Display off 0 : Display on RESET 1 : Being reset 0 : Normal
Write display data	1	1	0	Write data								Writes data from data bus into display RAM.
Read display data	1	0	1	Read data								Reads data from display RAM onto data bus.
Select ADC	0	1	0	1	0	1	0	0	0	0	0/1	0 : CW output, 1 : CCW output
Static drive ON/OFF	0	1	0	1	0	1	0	0	1	0	0/1	Selects static driving operation. 1 : Static drive, 0 : Normal driving
Select duty	0	1	0	1	0	1	0	1	0	0	0/1	Selects LCD duty cycle 1 : 1/32, 0 : 1/16
Read-Modify-Write	0	1	0	1	1	1	0	0	0	0	0	Read-modify-write ON
End	0	1	0	1	1	1	0	1	1	1	0	Read-modify-write OFF
Reset	0	1	0	1	1	1	0	0	0	1	0	Software reset

10. Precaution For Using LCM

1. LIQUID CRYSTAL DISPLAY (LCD)

LCD is made up of glass, organic sealant, organic fluid, and polymer based polarizers. The following precautions should be taken when handling,

- (1). Keep the temperature within range of use and storage. Excessive temperature and humidity could cause polarization degradation, polarizer peel off or bubble.
- (2). Do not contact the exposed polarizers with anything harder than an HB pencil lead. To clean dust off the display surface. Wipe gently with cotton. Chamois or other soft material soaked in petroleum benzine.
- (3). Wipe off saliva or water drops immediately. Contact with water over a long period of time may cause polarizer deformation or color fading, while an active LCD with water condensation on its surface will cause corrosion of ITO electrodes.
- (4). Glass can be easily chipped or cracked from rough handling, especially at corners and edges.
- (5). Do not drive LCD with DC voltage.

2. Liquid Crystal Display Modules

2.1 Mechanical Considerations

LCM are assembled and adjusted with a high degree of precision. Avoid excessive shocks and do not make any alterations or modifications. The following should be noted.

- (1). Do not tamper in any way with the tabs on the tabs on the metal frame.
- (2). Do not modify the PCB by drilling extra holes, changing its outline, moving its components or modifying its pattern.
- (3). Do not touch the elastomer connector, especially insert an backlight panel (for example, EL).
- (4). When mounting a LCM make sure that the PCB is not under any stress such as bending or twisting. Elastomer contacts are very delicate and missing pixels could result from slight dislocation of any of the elements.
- (5). Avoid pressing on the metal bezel, otherwise the elastomer connector could be deformed and lose contact, resulting in missing pixels.

2.2. Static Electricity

LCM contains CMOS LSI's and the same precaution for such devices should apply, namely

- (1). The operator should be grounded whenever he/she comes into contact with the module. Never touch any of the conductive parts such as the LSI pads, the copper leads on the PCB and the interface terminals with any parts of the human body.
- (2). The modules should be kept in antistatic bags or

other containers resistant to static for storage.

- (3). Only properly grounded soldering irons should be used.
- (4). If an electric screwdriver is used, it should be well grounded and shielded from commutator sparks.
- (5). The normal static prevention measures should be observed for work clothes and working benches; for the latter conductive (rubber) mat is recommended.
- (6). Since dry air is inductive to statics, a relative humidity of 50-60% is recommended.

2.3. Soldering

- (1). Solder only to the I/O terminals.
- (2). Use only soldering irons with proper grounding and no leakage.
- (3). Soldering temperature: $280\text{ }^{\circ}\text{C} \pm 10^{\circ}\text{C}$
- (4). Soldering time: 3 to 4 sec.
- (5). Use eutectic solder with resin flux fill.
- (6). If flux is used, the LCD surface should be covered to avoid flux spatters. Flux residue should be removed afterwards.

2.4. Operation

- (1). The viewing angle can be adjusted by varying the LCD driving voltage V_0 .
- (2). Driving voltage should be kept within specified range; excess voltage shortens display life.
- (3). Response time increases with decrease in temperature.
- (4). Display may turn black or dark blue at temperatures above its operational range; this is (however not pressing on the viewing area) may cause the segments to appear "fractured".
- (5). Mechanical disturbance during operation (such as pressing on the viewing area) may cause the segments to appear "fractured".

2.5. Storage

If any fluid leaks out of a damaged glass cell, wash off any human part that comes into contact with soap and water. Never swallow the fluid. The toxicity is extremely low but caution should be exercised at all the time.

2.6. Limited Warranty

Unless otherwise agreed between EASTERNTRONIC and customer, EASTERNTRONIC will replace or repair any of its LCD and LC, which is found to be defective electrically and visually when inspected in accordance with EASTERNTRONIC acceptance standards, for a period on one year from date of shipment. Confirmation of such date shall be based on freight documents. The warranty liability of EASTERNTRONIC is limited to repair and/or replacement on the terms set forth above. EASTERNTRONIC will not be responsible for any subsequent or consequential events.



11. Quality units

11.1 Purpose

This standard for quality assurance should define the quality of LCD module products to customer by EASTERNTRONIC LCD GROUP.

11.2 Scope

This document defines general provisions as well as inspection standards for LCD module supplied by EASTERNTRONIC LCD GROUP, except for those with special requirements from customer.

11.3 Definition

11.3.1 Definition of area

A Zone: Active area.

B Zone: Viewing area

C Zone: Outside viewing area.

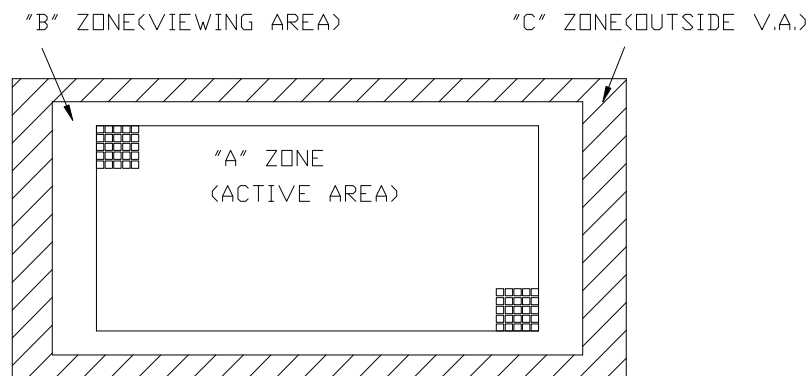

11.3.2 Definition of size

Large size(L): 1~6 pcs LCD screens are cut out of from each 14"×16" mother glass.

Middle size(M): 7~50 pcs LCD screens are cut out of from each 14"×16" mother glass.

Small size(S): more than 50 pcs LCD screens are cut out of from each 14"×16" mother glass.

11.4 Quality Specification

11.4.1 Conditions of Cosmetic Inspection

11.4.1 Test should be conducted under the following conditions:

Ambient temperature : $22 \pm 5^{\circ}\text{C}$.

Ambient humidity: $65 \pm 20\% \text{RH}$

Ambient Luminance: 40-watt fluorescent lamp.

An appearance test should be conducted by human sight at approximately 30 cm distance from the LCD module under fluorescent light. Distance between LCD and fluorescent lamps should be 100 cm or more. Viewing direction for inspection is 45° from vertical against LCD.

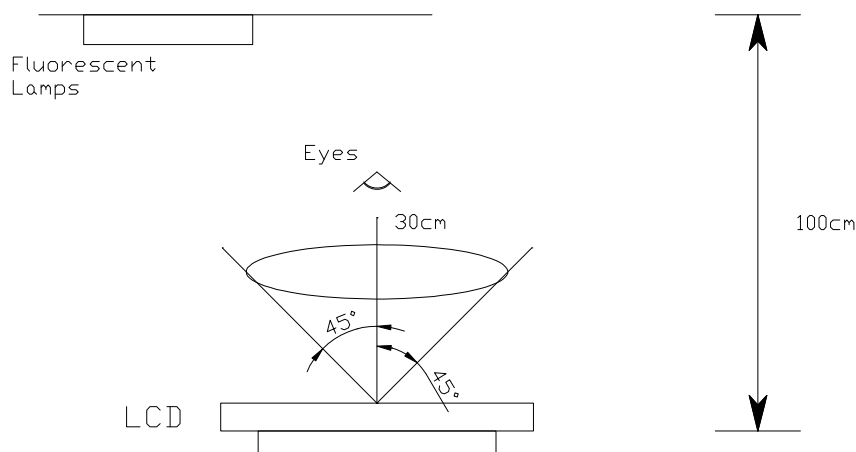

11.4.1.2 When test the model of transmissive product must add the reflective plate.

11.4.2 Sampling plan

Unless otherwise agreed in writing, the sampling inspection shall be applied to the incoming inspection of customer.

- Lot size: Quantity of shipment lot per model
- Sampling type: Normal inspection, single sampling
- Sampling Level: Level II
- Sampling table: GB/T2828.1.1 (GB-national standard of China)

11.4.3 Classification of defects and Acceptable quality level

Defects and classified as either a major or minor defect defined as bellows:

- Major defect: It is a defect that is likely to result in failure or to reduce materially the usability of the product for the intended function.
- Minor defect: It is a defect that will not result in functioning problem with deviation classification.

The AQL for major and minor defects is defined as follows:

Partition	Definition	AQL
Major defect	Functional defective as product	0.4
Minor defect	Satisfy all functions as product but not satisfy cosmetic standard	1.0

11.4.4 Applicable instrument

- LCD module tester
- Multimeter
- Caliper
- Defect size filming standard

11.4.5 Inspection quality criterion

11.4.5.1 LCD panel part

The inspection specification as following list:

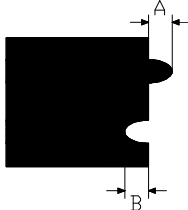
Classify	Item	Description of defects	Inspection criterion		Drawing specification
Major defect	1.Non-display	Product no function	Not accept		
	2.LCD with wrong view direction`	Difference in Spec.	Not accept		
	3.Segment missing	Part or all pattern do not light up	Not accept		
	4.Occur high current	Current exceed designed value	Not accept		
	5. LC leakage	LC does not fulfill the glass cell	Not accept		
	6.Deviation from drawing	LCM Dimension difference from drawing and over tolerance	According to dimensions noted in the specification		
	7.Wrong type applied	Wrong polarizer attachment	Not accept		
		Pin attached wrong type applied	Not accept		
8.Incorrect pins quality	Pin attached wrong quantity applied	Not accept			
Minor defect	9.Pattern deformation	Segment fatter or smaller	Dimension (mm)	Acceptable number	
			$A \leq 0.1$	Not count (Should not be connected to next dot)	
			$0.10 < A \leq 0.15$	1 pc / dot (only segment) or less 2 pcs / cell or less (Should not be connected to next dot)	
			$B \leq 0.10$	Not count	
Minor defect	10.Pinholes	Black spot/white spot at activated state	1. large size LCD Accept if can't be found at 1m distance and will not enlarge under electronic test 2. Middle size LCD Diameter(mm) Accept QTY		

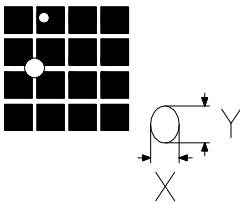
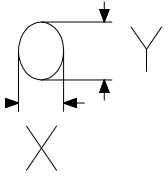
			<p> $\Phi \leq 0.15$ Not count $0.15 < \Phi \leq 0.25$ 3 $0.25 < \Phi \leq 0.35$ 1 $\Phi > 0.35$ 0 3. Small size LCD Diameter(mm) Accept QTY $\Phi \leq 0.15$ Not count $0.15 < \Phi \leq 0.25$ 2 $0.25 < \Phi \leq 0.30$ 1 $\Phi > 0.30$ 0 4. For the dot pattern: accept if the area of defect is less than or equal to half of one lattice's 5. Only allow one defect in one segment 6. The nearest distance allowed between two pinholes is 20mm </p>	 <p>$\Phi = (X+Y)/2$</p>
<p>11. Blemishes and foreign matters</p>	<p>Black spot/dust on LCD(non-display)</p>	<p>Positive panel: 1.A zone - Large size LCD Accept if can't find at 1m distance and will not enlarge under electronic test: -Middle size LCD Diameter(mm) Accept QTY $\Phi \leq 0.15$ Not count $0.15 < \Phi \leq 0.25$ 3 $0.25 < \Phi \leq 0.35$ 1 $\Phi > 0.35$ 0 -Small size LCD Diameter(mm) Accept QTY $\Phi \leq 0.15$ Not count $0.15 < \Phi \leq 0.25$ 2 $0.25 < \Phi \leq 0.30$ 1 $\Phi > 0.30$ 0 2.B zone 1.5 times of acceptable largest diameter size of Zone A</p>	 <p>$\Phi = (X+Y)/2$</p>	

			<p>3.C zone</p> <p>Notcount.</p> <p>Negative panel:</p> <p>1. A zone</p> <p>-Large size LCD</p> <p>Diameter(mm) Accept QTY</p> <table> <tr> <td>$\Phi \leq 0.15$</td> <td>Not count</td> </tr> <tr> <td>$0.15 < \Phi \leq 0.30$</td> <td>4</td> </tr> <tr> <td>$0.30 < \Phi \leq 0.50$</td> <td>1</td> </tr> <tr> <td>$\Phi > 0.50$</td> <td>0</td> </tr> </table> <p>-Middle&small size LCD</p> <p>Diameter(mm) Accept QTY</p> <table> <tr> <td>$\Phi \leq 0.15$</td> <td>Not count</td> </tr> <tr> <td>$0.15 < \Phi \leq 0.25$</td> <td>3</td> </tr> <tr> <td>$\Phi > 0.25$</td> <td>0</td> </tr> </table> <p>2. B zone</p> <p>1.5 times of acceptable largest diameter size of Zone A</p> <p>3.C zone</p> <p>No count</p> <p>The nearest diatance allowed between two black spot is 20mm</p>	$\Phi \leq 0.15$	Not count	$0.15 < \Phi \leq 0.30$	4	$0.30 < \Phi \leq 0.50$	1	$\Phi > 0.50$	0	$\Phi \leq 0.15$	Not count	$0.15 < \Phi \leq 0.25$	3	$\Phi > 0.25$	0	
$\Phi \leq 0.15$	Not count																	
$0.15 < \Phi \leq 0.30$	4																	
$0.30 < \Phi \leq 0.50$	1																	
$\Phi > 0.50$	0																	
$\Phi \leq 0.15$	Not count																	
$0.15 < \Phi \leq 0.25$	3																	
$\Phi > 0.25$	0																	

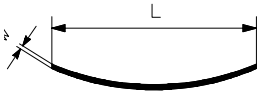
	<p>12.Black lines and scratches</p>	<p>Scratch on glass or polarizer surface.And foreign linear matters in LCD</p>	<p>Positive panel: 1.A zone - Large size LCD Accept if can't find at 1m distance and will not enlarge under electronic test.</p> <p>-Middle size LCD Diameter(mm) Accept QTY $W \leq 0.02$ Not count $0.02 < W \leq 0.03, L \leq 4$ 2 $0.03 < W \leq 0.05, L \leq 3$ 2 $0.02 < W \leq 0.03, L > 4$ 0 $0.03 < W \leq 0.05, L > 3$ 0 $W > 0.05$ As the spot criteria.</p> <p>-Small size LCD Diameter(mm) Accept QTY $W \leq 0.02$ Not count $0.02 < W \leq 0.03, L \leq 4$ 2 $0.03 < W \leq 0.05, L \leq 2$ 1 $0.02 < W \leq 0.03, L > 4$ 0 $0.03 < W \leq 0.05, L > 2$ 0 $W > 0.05$ As the spot criteria.</p> <p>2.B zone 1.5 times of acceptable largest diameter size of Zone A</p> <p>3.C zone Notcount.</p> <p>Negative panel: 1. A zone -Large size LCD Diameter(mm) Accept QTY $W \leq 0.02$ Not count $0.02 < W \leq 0.03, L \leq 5$ 3 $0.03 < W \leq 0.05, L \leq 4$ 2 $0.02 < W \leq 0.03, L > 5$ 0 $0.03 < W \leq 0.05, L > 4$ 0 $W > 0.05$ As the spot criteria.</p> <p>-Middle size LCD Diameter(mm) Accept QTY $W \leq 0.02$ Not count $0.02 < W \leq 0.03, L \leq 4$ 2 $0.03 < W \leq 0.05, L \leq 2$ 2 $0.02 < W \leq 0.03, L > 3$ 0 $0.03 < W \leq 0.05, L > 2$ 0</p>	
--	-------------------------------------	--	---	---

			<p>W>0.05 As the spot criteria. -Small size LCD Diameter(mm) Accept QTY W≤0.02 Not count 0.02< W≤0.03,L ≤3 2 0.03< W ≤0.05,L ≤3 1 0.02< W≤0.03,L >3 0 0.03< W ≤0.05,L >2 0 W>0.05 As the spot criteria.</p> <p>2. B zone 1.5 times of acceptable largest diameter size of Zone A</p> <p>3.C zone Not count The nearest distance allowed between two defects is 20mm</p>	
Mintor defect	13. Scratch on PI coating	PI coating scratched	The visible scratch of A zone can not be accepted at 30cm view distance.	
Mintor defect	14. Rainbow	Arches,circular or parallel colorful spread	According to the limit specimen	
Mintor defect	15. Bubbles or wrinkles in polarizer	Bubbles or wrinkles between polarizer and glass	A zone:The visible defect can not be accepted at 30cm view distance. B zone: Not count	
Mintor defect	16. Position of polarizer attachment	Wrong polarizer attachment in position or dimension	Polarizer protruding from edge of glass and exceeding/within the maximum external dimension of LCD	
Mintor defect	17. Ink printing defect	17.1 Ink line/pattern broken	Not accept	

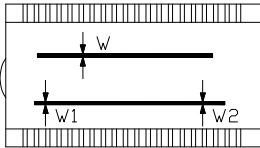
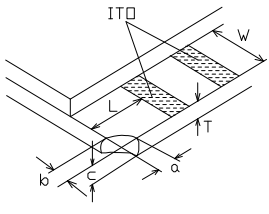
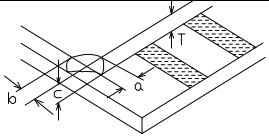
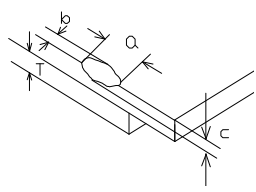
		17.2 Ink pattern/line jagged	Accept if the thick or thin part is less than equal to 25% segment width, or according to the limit specimen				
		17.3 Light leakage	When activated with current white light appears in the position of pinhole or scratch due to ink printing misalignment. According to the pinhole specification.				
		17.4 Ink printing pattern/line uneven	Reject if the thick or thin in more than 1/2W. Reject when $W1-W2 \leq 1/3W$				
Mintor defect	18. Pin defect	18.1 Corrosion or foreign material on terminal legs	Pin incoming defect: oxidized, damage (including pins plating damaged), excess epoxy on bottom glass or terminal legs. Not accept.				
		18.2 Pin deviation over tolerance	According to the specification				
Mintor defect	19. Chipped glass on comer	19.1 Chip in lead contact area.	a	b	c	accept QTY	
			$a \leq 5mm$ $L > 5mm$ m	$b \leq W$	$c \leq T$	3	
			$a < L$ $L < 5mm$ m	$b \leq W$	$c \leq T$	3	
		19.2 Others	Not exceed 1/2 width of seal	$c \leq T$	3		
Mintor defect	20. Glass chip on edge	a	b	c	accept QTY		
		$a \leq 5mm$	Not exceed 1/2 width of seal	$c \leq T$	3		

Mintor defect	21. Clipped electrode pad	21.1 Glass chip on ITO edge	a	b	c	accept QTY	
		a ≤ 4mm (and not exceed 4 ITO terminal)	b ≤ W/4	c ≤ T	3		
Mintor defect	22. Mechanical damage	21.2 Glass chip on ITO back	a	b	c	accept QTY	
		a ≤ 5mm	b ≤ W/3	c ≤ T	3		
Mintor defect	22. Mechanical damage	Extended crack inspector shall attempt to remove the chip with tweezers, re-evaluate if the remaining defect is still a crack or a chip	b			accept QTY	
			b ≤ W/4			2	
Mintor defect	23. Glass cracks		Not accept				

Remark:
 The minimum space between any 2 defects (spot, dirt) should more than 20mm, and max. allowed defect QTY in total:
 Large size LCD: Zone A ≤ 5/unit, Zone B ≤ 5/unit;
 Middle size LCD: Zone A ≤ 3/unit, Zone B ≤ 3/unit;
 Small size LCD: Zone A ≤ 2/unit, Zone B ≤ 2/unit;

11.4.5.2 Other part

The inspection specification as following list:

NO.	Items	Criterion of defects	AQL
1	Backlight	<ol style="list-style-type: none"> 1. Lumination source flickers. 2. Using spot, lines and contamination standard of LCD to judge the spots or scratches defect on backlight. 3. Not allow unlighted on backlight. 4. Colour and luminance of backlight should correspond its specification. 	<p>Major Minor</p> <p>Major Major</p>
2	PCB,COB	<ol style="list-style-type: none"> 1.COB seal may not have pinholes larger than0.2mm or contamination. 2.COB seal surface may not have pinholes through to the IC. 3. The height of COB should not exceed the height indicated in the assembly diagram. 4. Beyond 2mm of the seal area, there may not have sealant on the PCB. 5.No oxidation or contamination on PCB connector. 6.Parts on PCB should correspond the characteristic,and not allow wrong parts,missing parts or additional parts. 7.The jumper on the PCB should correspond to the characteristic. 8.The solder which gets on bezel,LED pad,zebra pad or screw hole pad should be smoothed down. 	<p>Minor</p> <p>Minor Major</p> <p>Minor</p> <p>Minor Major</p> <p>Minor</p> <p>Major</p>
3	Soldering	<ol style="list-style-type: none"> 1. No unmelted solder pastes on the PCB. 2. No cold solder joints,solder connection missing,oxidation of solder. 3. No short circuits in components on PCB. 	<p>Minor Minor</p> <p>Minor</p>
4	General Appearance	<ol style="list-style-type: none"> 1. No oxidation, contamination, curves,cracks or bends on interface Pin of TCP. 2. No solder residue or solder balls on product. 3. The IC on TCP may not be damaged. 4. The residual rosin or tin oil of soldering(component or chip component) is not turned into brown or black colour. 5. Packing method correspond the specification. 6. Dimension and structure correspond the specification sheet. 7. No dirt and break on the heat seal. 	<p>Minor</p> <p>Minor Major Minor</p> <p>Major Major</p> <p>Major</p>

11.5 Reliability

The LCD module shall not fail the following reliability test.

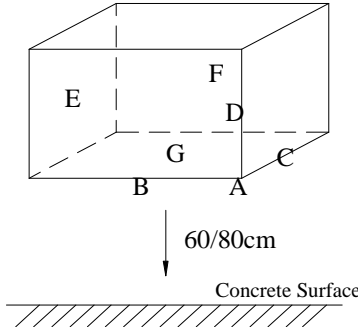
Item	Condition	Criterion	
High temperature operation	+70°C ± 2°C, 8 hours	1.Total current consumption should be below double of initial value. 2.Cosmetic defects should not be happened	
Low temperature operation	-20°C ± 2°C, 8 hours		
Humidity	Operation		40°C ± 2°C, 93% ± 2% RH, 8 hours
	Storage		40°C ± 2°C, 93% ± 2% RH, 24 hours
High temperature storage	+80°C ± 2°C, 10 hours		
Low temperature storage	-30°C ± 2°C, 10 hours		
Thermal shock storage	-20°C ~ +70°C 60min~60min, 5 cycles		
Vibration test	Amplitude:0.7~1.0mm,frequency:50Hz,30min in each direction(X,Y,Z)		
Shock test	To be measured after dropping from 60cm or 80cm high on the concrete surface in packing state.(weight ≥ 15Kg,dropping height 60cm; Weight < 15Kg,dropping height 80cm)  <p style="margin-left: 400px;">Dropping method corner dropping A corner: once Edge dropping B,C,D edge: once Face dropping E,F,G face: once</p>		
Remark: The function test shall be conducted after 4 hours storage at the normal temperature and humidity after removed from the test chamber.			

12. Declaration of conformity regarding the limitation of dangerous substances

深圳易事通液晶显示模块有限公司

SHENZHEN EASTERNTRONIC LCM CO., LTD.

4F, B3 Building, FuYuan Industrial Zone, FuYong Town,

BaoAn District, ShenZhen, P.R.China

DECLARATION OF CONFORMITY REGARDING THE LIMITATION OF DANGEROUS SUBSTANCES

WE, SHENZHEN EASTERNTRONIC LCM CO., LTD,

Declare that the product of GS12232C-D-BTXTSWW-110 complies with:
The directive 2002/95/EC Dated 2003/01/27 regarding the limitation of dangerous substances, in particular to clause 4 which forbids the use of the following elements:

- Lead
- Mercury
- Cadmium
- Hexavalent chromium
- Polybrominated biphenyls
- Polybrominated diphenylethers

And to the annex which points out the exempted implementations

To the directive 73/23/EEC dated 1973/02/19 and the standard EN60335-1 regarding prohibition of following elements:

- Oils containing polychlorinated biphenyl
- Asbestos
- Radioactive substances

Name: Ding

SHENZHEN EASTERNTRONIC LCM CO., LTD.

Issued on June 4, 2009

According with the proposal of Technical Adaption Committee (TAC) of a limit of 0.1% by weight for lead hexavalent chromium, mercury, PBBs and PBDRs and 0.01% by weight for Cadmium.