

DATA IMAGE CORPORATION

LCD Module Specification

Preliminary

ITEM NO.: GM241222GFSWBG06

Table of Contents

1. COVER & CONTENTS	1
2. RECORD OF REVISION	2
3. GENERAL SPECIFICATIONS	3
4. ABSOLUTELY MAXIMUM RATINGS	4
5. ELECTRICAL CHARACTERISTICS	6
6. ELECTRO-OPTICAL CHARACTERISTIC	6
7. TIMING CHARACTERISTICS	9
8. PIN CONNECTIONS	10
9. POWER SUPPLY	10
10. BLOCK DIAGRAM	11
11. QUALITY ASSURANCE	18
12. LOT NUMBERING SYSTEM	22
13. LCM NUMBERING SYSTEM	22
14. PRECAUTIONS IN USE LCM	23
15. OUTLINE DRAWING	24
16. PACKAGE INFORMATION	25

Customer Companies	QA Approval	QA Check	R&D Approval	R&D Check
	<i>pretty</i>	<i>Seven</i>	<i>Gromer</i>	<i>Terry</i>
Approved by	Version:	Issued Date:	Sheet Code:	Total Pages:
	1	05/MAR/14'		25



3. GENERAL SPECIFICATION

Display Format : 240 (W) × 128 (H) dots
Dots Size : 0.40 (W) × 0.40 (H) mm
View Area : 114 (W) × 64 (H) mm
General Dimensions : 144 (W) × 104 (H) × 15.8 (T) mm Max.

Weight : 250 g max.

LCD Type & Background Color: STN Blue Gray STN Yellow Green FSTN Dark Blue

Polarizer mode : Reflective Transflective

Transmissive Negative

View Angle : 6 O'clock 12 O'clock Others _____

Backlight : LED EL CCFL

Backlight Color : Yellow green Amber Blue Green

White Others

Controller/Driver : RA6963/ NT7086

Temperature Range : Normal Wide Temperature
Operating 0 to 50°C Operating -20 to 70°C
Storage -20 to 70°C Storage -30 to 80°C

Pixel Color: Blue

REMARK:

Our components and processes are compliant to RoHS standard

4. ABSOLUTE MAXIMUM RATINGS

4.1 ELECTRICAL ABSOLUTE MAXIMUM RATINGS

$V_{SS}=0V, T_a = 25^{\circ}C$

Item	Symbol	Min.	Max.	Unit
Supply Voltage (Logic)	VDD-VSS	-0.3	7	V
Supply Voltage (LCD Driver)	VDD-VO	0	25	V
Input Voltage	VI	-0.3	VDD+0.3	V
Operating Temperature	TOP	-20	70	°C
Storage Temperature	TSTG	-30	80	°C

4.2 ENVIRONMENTAL ABSOLUTE MAXIMUM RATINGS

Item	Operating		Storage		Comment
	(Min.)	Max.)	(Min.)	(Max.)	
Ambient Temp	-20	70	-30	80	Note (1)
Humidity	Note (2)		Note(2)		Without Condensation
Vibration	--	4.9M/S ²	--	19.6M/S ²	XYZ Direction
Shock	--	29.4M/S ²	--	490M/S ²	XYZ Direction

Note(1) $T_a = 0^{\circ}C : 50Hr$ Max.

Note(2) $T_a \leq 40^{\circ}C : 90\%$ RH Max.

$T_a \geq 40^{\circ}C :$ Absolute humidity must be lower than the humidity of 90% RH at 40°C.

4.3 Electronic Static Discharge maximum rating

ESD test method : IEC61000-4-2

Item	Description
Testing environment	Ambient temperature :15°C to 35 °C Humidity: 30% to 60 % LCM (E.U.T) : Power up
Testing equipment	Manufacture: Noise Ken , Model No. ESD-100L
Testing condition	See drawing 1
Direct discharge	0 to ± 6 KV Discharge point, see drawing 2
Indirect discharge	0 to ± 12KV Discharge point, see drawing 1
Pass condition	No malfunction of unit. Temporary malfunction of unit which can be recovered by system reset
Fail condition	Non. Recoverable malfunction of LCM or system

FIG 1 ESD TESTING EQUIPMENT

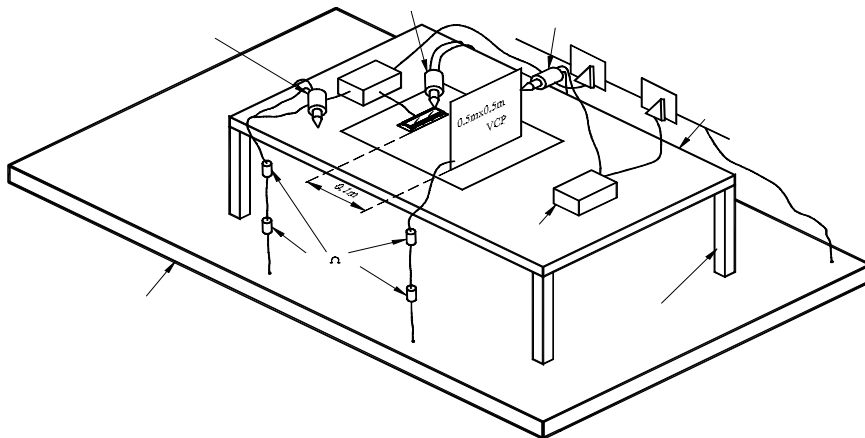

(1)

DIRECT CONTACT DISCHARGE CONTACT POINT : A.B.C.D

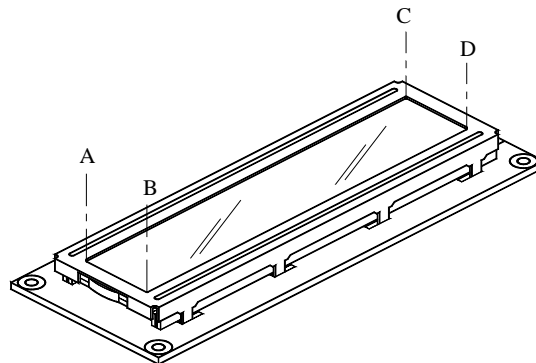

(2)

5. ELECTRICAL CHARACTERISTICS

Item	Symbol	Condition	Min.	Typ.	Max.	Unit
Supply Voltage (Logic)	VDD-VSS		4.5	5.0	5.5	V
Supply Voltage (LCD)	VDD-VO	-20°C	19.5	20.0	20.5	V
		25°C	16.8	17.5	18.2	
		70°C	14.5	15.0	16.0	
Input Voltage	V _{IH}	--	0.8V _{DD}	--	V _{DD}	V
	V _{IL}		V _{SS}	--	0.2V _{DD}	
Logic Supply Current	I _{DD}	V _{DD} =5.0V	--	33	--	mA

6. ELECTRO-OPTICAL CHARACTERISTICS

ITEM	Symbol	Condition	Min.	Typ.	Max.	Unit	Ref.
Rise Time	Tr	-20°C	--	--	12000	ms	Note (1)
		25°C		--	300		
Fall Time	Tf	-20°C	--	--	12000	ms	
		25°C		--	300		
Contrast	CR	25°C	3	--	--		Note (3)
View Angle	θ ₁ ~θ ₂ ∅ ₁ , ∅ ₂	When CR≥2	-20	--	30	deg	Note (2)
			-30	--	-30		
Frame Frequency	Ff	25°C	32	64	200	Hz	

Note (1) & (2) : See next page

Note (3) : Contrast ratio is defined under the following condition:

$$CR = \frac{\text{Brightness of non-selected condition}}{\text{Brightness of selected condition}}$$

- (a). Temperature ----- 25°C
- (b). Frame frequency ---- 64Hz
- (c). Viewing angle ----- θ= 0°, ∅ = 0°
- (d). Operating voltage --- 17.5V

Note (1) Response time is measured as the shortest period of time possible between the change in state of an LCD segment as demonstrated below:

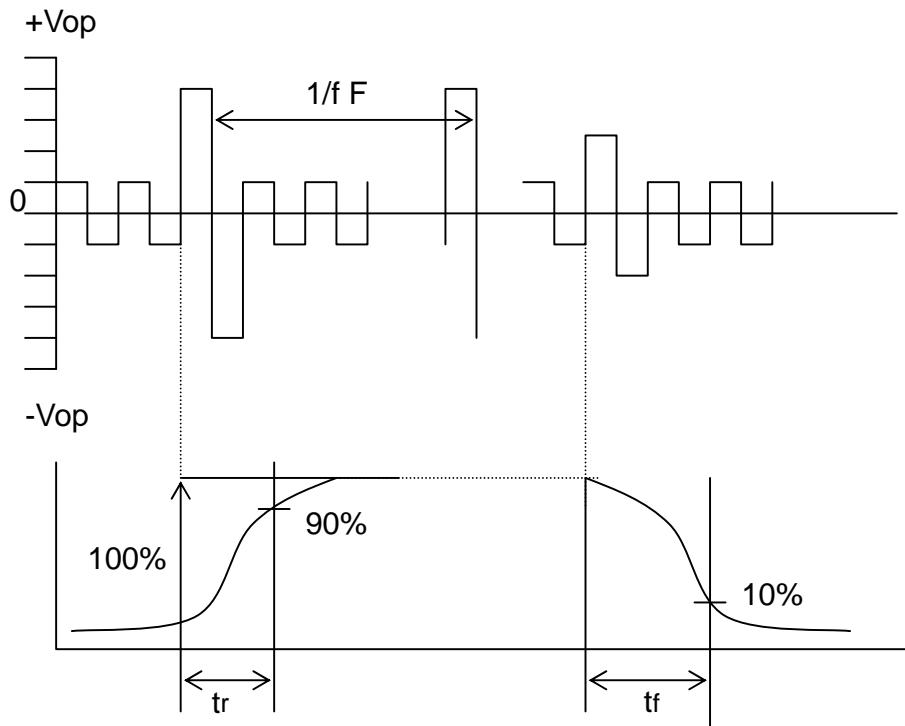

Condition:

- (a) . Temperature -----25°C
- (b) . Frame frequency ----- 64Hz
- (c) . View Angle ----- $\theta = 0^\circ, \varnothing=0^\circ$
- (d) . Operating voltage ----- 17.5V

Note (2) Definition of View Angle

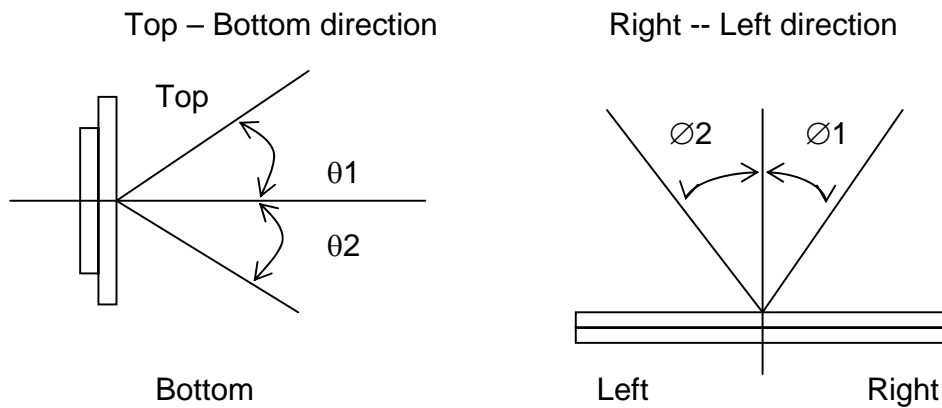

6.1 LED ELECTRO-OPTICAL CHARACTERISTICS

Ta = 25°C

Item	Symbol	Condition	Min.	Typ.	Max.	Unit
Forward Voltage	V _F	I _F = 120mA White	--	3.4	3.8	V
Luminous Intensity	I _v	I _F = 120mA White	100	120	--	cd/m ²
Chromaticity	X	I _F = 120mA White	0.28	0.31	0.36	nm
	Y		0.27	0.32	0.37	

Note : Measured at the bared LED backlight unit.

6.2 LED MAXIMUM OPERATING RANGE

Item	Symbol	White	Unit
Power Dissipation	P _{AD}	0.456	W
Forward Current	I _{AF}	120	mA
Reverse Voltage	V _R	5	V

6.2.1 LED ARRAY BLOCK DIAGRAM

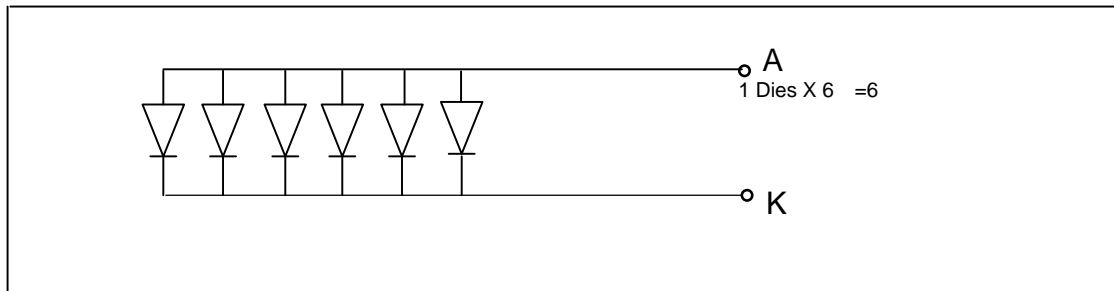

7. TIMING CHARACTERISTICS

Switching Characteristics (2)

Bus Timing

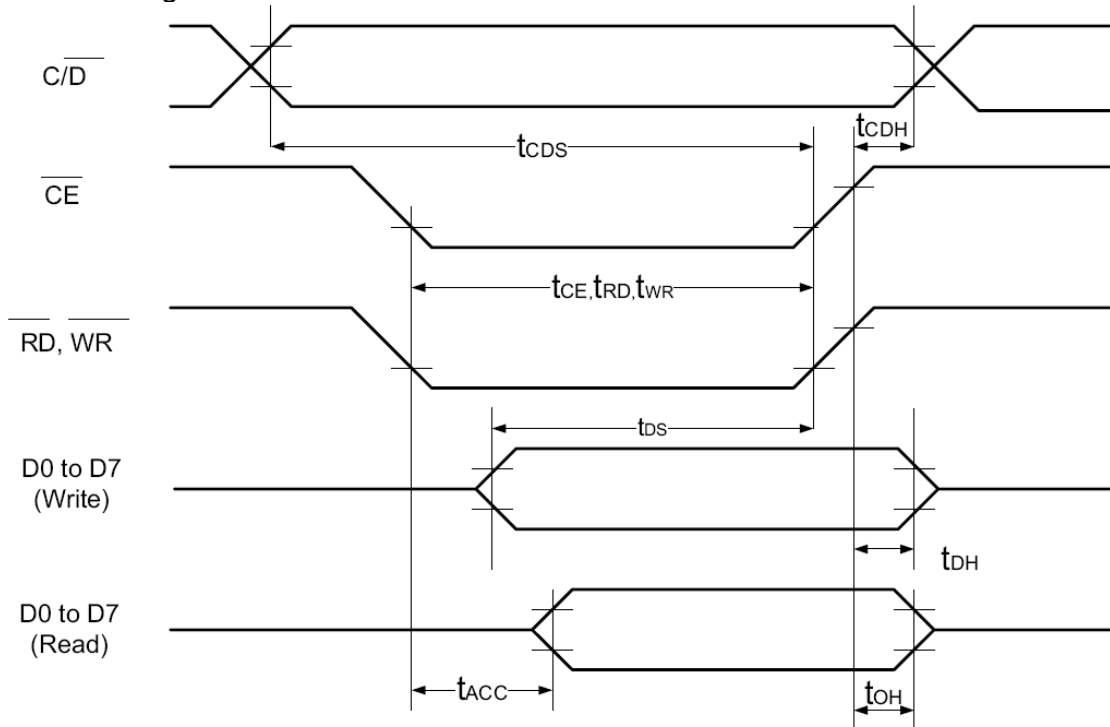

TEST CONDITIONS (Unless otherwise noted. $V_{DD} = 5.0V \pm 10\%$, $V_{SS} = 0V$, $T_a = -20$ to $75^\circ C$)

ITEM	SYMBOL	TEST CONDITIONS	MIN	MAX	UNIT
C / D Set-up Time	t_{CDS}	--	100	--	ns
C / D Hold Time	t_{CDH}	--	10	--	ns
CE, RD, WR Pulse Width	t_{CE}, t_{RD}, t_{WR}	--	80	--	ns
Data Set-up Time	t_{DS}	--	80	--	ns
Data Hold Time	t_{DH}	--	40	--	ns
Access Time	t_{ACC}	--	--	150	ns
Output Hold Time	t_{OH}	--	10	50	ns

8. PIN CONNECTIONS

Pin	Symbol	Function
1	V _{SS}	Ground (0V)
2	V _{DD}	Power Supply Voltage
3	V _O	Power Supply for LCD (-V)
4	$\overline{C/D}$	L : DATA H : Instruction Code
5	\overline{RD}	Data Read
6	\overline{WR}	Data Write
7	DB0	Data Bus Line
8	DB1	
9	DB2	
10	DB3	
11	DB4	
12	DB5	
13	DB6	
14	DB7	
15	\overline{CE}	Enable Signal
16	\overline{RST}	Reset Signal
17	Vout	Negative Voltage Output for LCD
18	MD	H:32/L:40 Selection of Columns
19	FS	Font Select, L =8x8, H =6x8
20	NC	No Connection
21	LED A	Power supply for LED/EL B.L(+)
22	LED K	Power supply for LED /EL B.L(-)

9. POWER SUPPLY

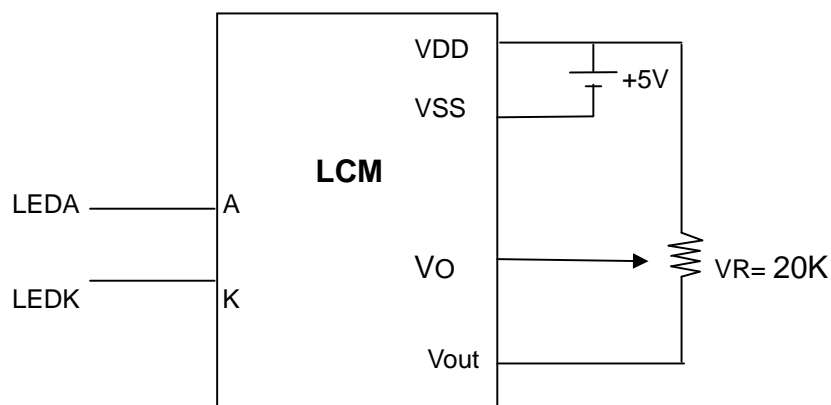

10. BLOCK DI AGRAM

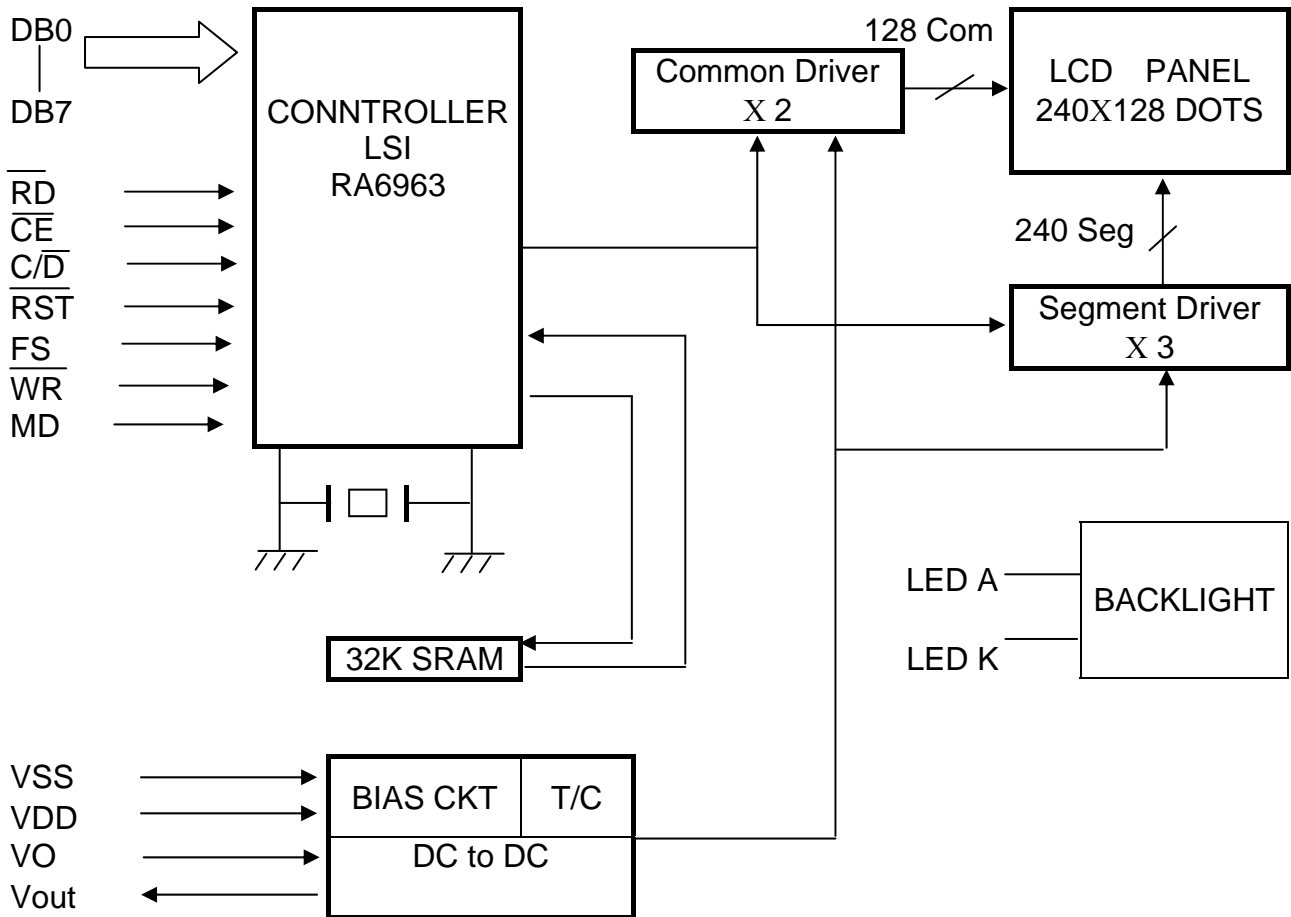

• Flowchart of communications with MPU

(1) Status Read

A status check must be performed before data is read or written.

Status check

The Status of RA6963L2NA can be read from the data lines.

<u>RD</u>	L
<u>WR</u>	H
<u>CE</u>	L
C / D	H
D0 to D7	Status word

The RA6963L2NA status word format is as follows:

MSB							LSB
STA7 D7	STA6 D6	STA5 D5	STA4 D4	STA3 D3	STA2 D2	STA1 D1	STA0 D0

STA0	Check command execution capability	0 : Disable 1 : Enable
STA1	Check data read / write capability	0 : Disable 1 : Enable
STA2	Check Auto mode data read capability	0 : Disable 1 : Enable
STA3	Check Auto mode data write capability	0 : Disable 1 : Enable
STA4	Not used	
STA5	Check controller operation capability	0 : Disable 1 : Enable
STA6	Error flag. Used for Screen Peek and Screen copy commands.	0 : No error 1 : Error
STA7	Check the blink condition	0 : Display off 1 : Normal display

- (Note 1) It is necessary to check STA0 and STA1 at the same time.
There is a possibility of erroneous operation due to a hardware interrupt.
- (Note 2) For most modes STA0 / STA1 are used as a status check.
- (Note 3) STA2 and STA3 are valid in Auto mode; STA0 and STA1 are invalid.

Status checking flow

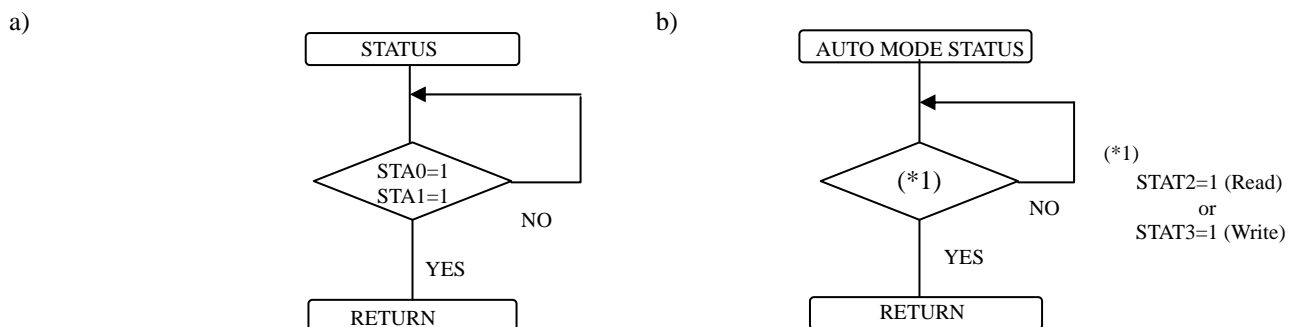

- (Note 4) When using the MSB = 0 command, a Status Read must be performed.
If a status check is not carried out, the RA6963L2NA cannot operate normally, even after a delay time.
The hardware interrupt occurs during the address calculation period (at the end of each line).
If a MSB = 0 command is sent to the RA6963L2NA during this period, the RA6963L2NA enters Wait status.
If a status check is not carried out in this state before the next command is sent, there is the Possibility that the command or data will not be received.

(2) Setting data

When using the RA6963L2NA, first set the data, then set the command.

Procedure for sending a command

a) The case of 1 data

b) The case of 2 data

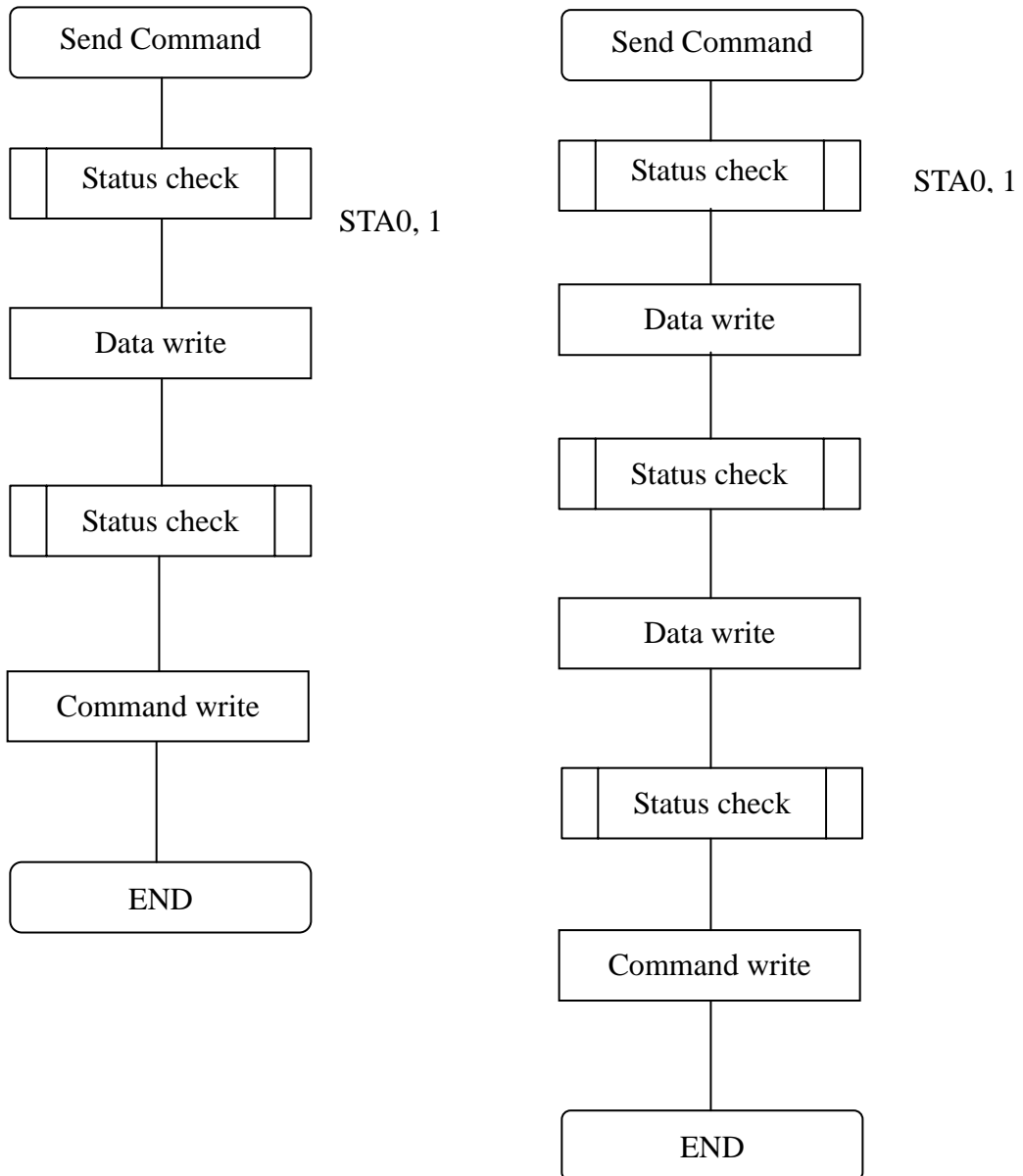

(Note) When sending more than two data, the last datum (or last two data) is valid.

COMMAND DEFINITIONS

COMMAND	CODE	D1	D2	FUNCTION
REGISTERS SETTING	00100001	X address	Y address	Set Cursor Pointer
	00100010	Data	00H	Set Offset Register
	00100100	Low address	High address	Set Address Pointer
SET CONTROL WORD	01000000	Low address	High address	Set Text Home Address
	01000001	Columns	00H	Set Text Area
	01000010	Low address	High address	Set Graphic Home Address
	01000011	Columns	00H	Set Graphic Area
MODE SET	1000X000	—	—	OR mode
	1000X001	—	—	EXOR mode
	1000X011	—	—	AND mode
	1000X100	—	—	Text Attribute mode
	10000XXX	—	—	Internal CG ROM mode
	10001XXX	—	—	External CG RAM mode
DISPLAY MODE	10010000	—	—	Display off
	1001XX10	—	—	Cursor on, blink off
	1001 XX11	—	—	Cursor on, blink on
	100101 XX	—	—	Text on, graphic off
	100110 XX	—	—	Text off, graphic on
	100111 XX	—	—	Text on, graphic on
CURSOR PATTERN SELECT	10100000	—	—	1-line cursor
	10100001	—	—	2-line cursor
	10100010	—	—	3-line cursor
	10100011	—	—	4-line cursor
	10100100	—	—	5-line cursor
	10100101	—	—	6-line cursor
	10100110	—	—	7-line cursor
	10100111	—	—	8-line cursor
DATA AUTO READ / WRITE	10110000	—	—	Set Data Auto Write
	10110001	—	—	Set Data Auto Read
	10110010	—	—	Auto Reset
DATA READ / WRITE	11000000	Data	—	Data Write and Increment ADP
	11000001	—	—	Data Read and Increment ADP
	11000010	Data	—	Data Write and Decrement ADP
	11000011	—	—	Data Read and Decrement ADP
	11000100	Data	—	Data Write and Nonvariable ADP
	11000101	—	—	Data Read and Nonvariable ADP
SCREEN PEEK	11100000	—	—	Screen Peek
SCREEN COPY	11101000			Screen Copy
BIT SET / RESET	11110XXX	—	—	Bit Reset
	11111XXX	—	—	Bit Set
	1111X000	—	—	Bit 0 (LSB)
	1111X001	—	—	Bit 1
	1111X010	—	—	Bit 2
	1111X011	—	—	Bit 3
	1111X100	—	—	Bit 4
	1111X101	—	—	Bit 5
	1111X110	—	—	Bit 6
	1111X111	—	—	Bit 7 (MSB)

X : invalid

- Setting registers

CODE	HEX.	FUNCTION	D1	D2
00100001	21H	SET CURSOR POINTER	X ADRS	Y ADRS
00100010	22H	SET OFFSET REGISTER	DATA	00H
00100100	24H	SET ADDRESS POINTER	LOW ADRS	HIGH ADRS

(1) Set Cursor Pointer

The position of the cursor is specified by X ADRS and Y ADRS. The cursor position can only be moved by this command. Data read / write from the MPU never changes the cursor pointer. X ADRS and Y ADRS are specified as follows.

X ADRS 00H to 4FH (lower 7 bits are valid)

Y ADRS 00H to 1FH (lower 5 bits are valid)

a) Single – Scan

X ADRS 00 to 4FH

b) Dual – Scan

X ADRS 00 to 4FH

Y ADRS 00H to 0FH

Y ADRS 00H to 0FH
Upper screen

Y ADRS 00H to 1FH
Lower screen

(2) Set Offset Register

The offset register is used to determine the external character generator RAM area.

The RA6963L2NA has a 16-bit address bus as follows:

MSB															LSB
ad15	ad14	ad13	ad12	ad11	ad10	ad9	ad8	ad7	ad6	ad5	ad4	ad3	ad2	ad1	ad0

Offset Register Data

Character Code

Line Scan

CHARACTER CODE MAP
 ROM code 0101

LSB MSB	0	1	2	3	4	5	6	7	8	9	A	B	C	D	E	F
0		!	"	#	\$	%	&	'	()	*	+	,	-	.	/
1	0	1	2	3	4	5	6	7	8	9	:	;	<	=	>	?
2	a	A	B	C	D	E	F	G	H	I	J	K	L	M	N	O
3	P	Q	R	S	T	U	V	W	X	Y	Z	[\]	^	_
4	~	a	b	c	d	e	f	g	h	i	j	k	l	m	n	o
5	p	q	r	s	t	u	v	w	x	y	z	{		}	~	
6	ö	ü	é	à	â	ä	å	ç	ê	ë	è	ì	í	î	ä	ä
7	ë	æ	œ	ø	ö	ö	ö	ü	ü	ü	ü	ø	ø	ø	æ	æ

10. 1 DISPLAY PATTERN

FIRST DATA

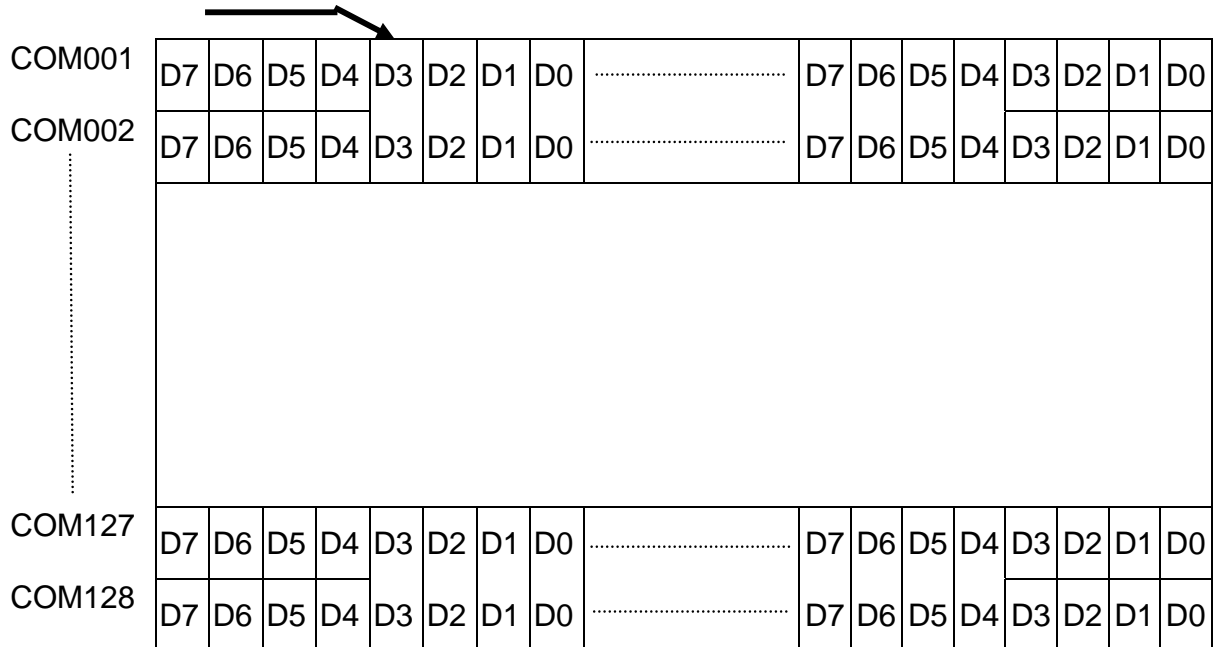

SEG001

SEG002

SEG239

SEG240

240*128 Dots Matrix

11. QUALITY ASSURANCE

11.1 Test Condition

11.1.1 Temperature and Humidity(Ambient Temperature)

Temperature : $20 \pm 5^{\circ}\text{C}$

Humidity : $65 \pm 5\%$

11.1.2 Operation

Unless specified otherwise, test will be conducted with LCM in operation.

11.1.3 Container

Unless specified otherwise, vibration test will be conducted on module only.

11.1.4 Test Frequency

Single cycle.

11.1.5 Test Method

No.	Parameter	Conditions	Regulations
1	High Temperature Operating	70°C, 96h	IEC68-2-2
2	Low Temperature Operating	-20°C, 96h	IEC68-2-1
3	High Temperature Storage	80°C, 96h	IEC68-2-2
4	Low Temperature Storage	-30°C, 96h	IEC68-2-1
5	High temperature and high humidity operation test	60°C, 90%RH, 96h	IEC68-2-3
6	Thermal cycling storage test	-30°C ---- 50°C ----- 80°C ,10Cycle 30min 5min 30min	IEC68-2-14
7	vibration test	Frequency:10~55HZ Amplitude:1.5mm Sweep time:11min Test period:6Cycles for each direction of X,Y,Z	IEC68-2-6
8	Drop test	Height :60cm 1 conner,3edges,6surfaces	IEC68-2-32
9	Shock Test	100G,6ms,Direction:±X±Y±Z Cycle:3times	IEC68-2-27

Note 1: Returned under normal temperature and humidity for 4 hrs.

Note 2: No dew condensation to be observed.

Note 3: No change on display and in operation under the test condition

11.2 Inspection condition

11.2.1 Inspection conditions

The LCD shall be inspected under 40W white fluorescent light.

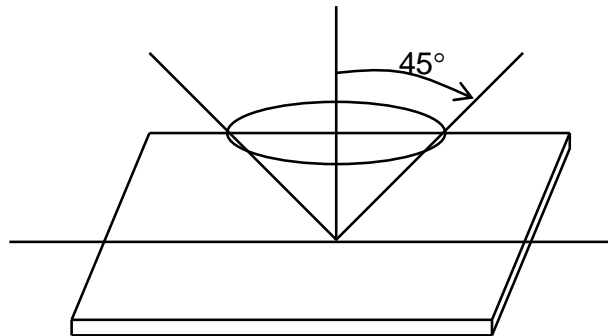

11.2.2 Definition of applicable Zones

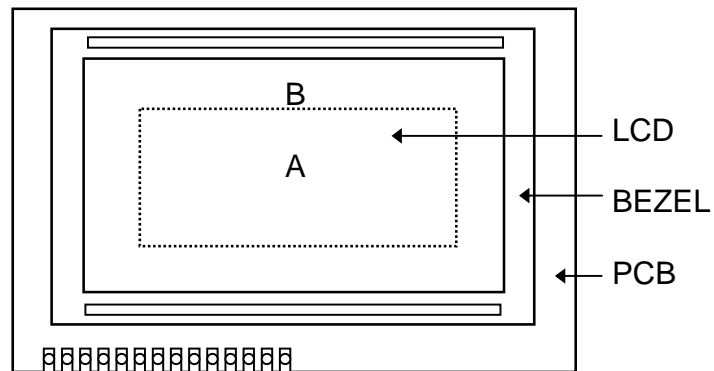

A : Display Area
B : Non-Display Area

11.2.3 Inspection Parameters

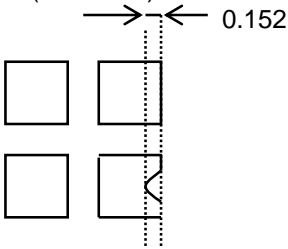
No.	Parameter	Criteria																												
1	Black or White spots	<table border="1"> <thead> <tr> <th rowspan="2">Zone Dimension</th> <th colspan="2">Acceptable number</th> <th rowspan="2">Class Of Defects</th> <th rowspan="2">AQL Level</th> </tr> <tr> <th>A</th> <th>B</th> </tr> </thead> <tbody> <tr> <td>$D \leq 0.15$</td> <td>*</td> <td>*</td> <td rowspan="3">Minor</td> <td rowspan="3">2.5</td> </tr> <tr> <td>$0.15 < D \leq 0.2$</td> <td>4</td> <td>4</td> </tr> <tr> <td>$0.2 < D \leq 0.3$</td> <td>2</td> <td>2</td> </tr> </tbody> </table> <p style="text-align: center;">$D = (\text{Long} + \text{Short}) / 2$ * : Disregard</p>	Zone Dimension	Acceptable number		Class Of Defects	AQL Level	A	B	$D \leq 0.15$	*	*	Minor	2.5	$0.15 < D \leq 0.2$	4	4	$0.2 < D \leq 0.3$	2	2										
Zone Dimension	Acceptable number			Class Of Defects	AQL Level																									
	A	B																												
$D \leq 0.15$	*	*	Minor	2.5																										
$0.15 < D \leq 0.2$	4	4																												
$0.2 < D \leq 0.3$	2	2																												
2	Scratch, Substances	<table border="1"> <thead> <tr> <th colspan="2">Zone X (mm) Y(mm)</th> <th colspan="2">Acceptable number</th> <th rowspan="2">Class Of Defects</th> <th rowspan="2">AQL Level</th> </tr> <tr> <th colspan="2"></th> <th>A</th> <th>B</th> </tr> </thead> <tbody> <tr> <td>*</td> <td>$W \leq 0.04$</td> <td>*</td> <td>*</td> <td rowspan="4">Minor</td> <td rowspan="4">2.5</td> </tr> <tr> <td>$L \leq 3.0$</td> <td>$0.04 < W \leq 0.06$</td> <td>4</td> <td>4</td> </tr> <tr> <td>$L \leq 2.0$</td> <td>$0.06 < W \leq 0.08$</td> <td>2</td> <td>3</td> </tr> <tr> <td>—</td> <td>$0.08 < W \leq 0.1$</td> <td>0</td> <td>1</td> </tr> </tbody> </table> <p style="text-align: center;">X : Length Y : Width * : Disregard Total defects should not exceed 4/module</p>	Zone X (mm) Y(mm)		Acceptable number		Class Of Defects	AQL Level			A	B	*	$W \leq 0.04$	*	*	Minor	2.5	$L \leq 3.0$	$0.04 < W \leq 0.06$	4	4	$L \leq 2.0$	$0.06 < W \leq 0.08$	2	3	—	$0.08 < W \leq 0.1$	0	1
Zone X (mm) Y(mm)		Acceptable number		Class Of Defects	AQL Level																									
		A	B																											
*	$W \leq 0.04$	*	*	Minor	2.5																									
$L \leq 3.0$	$0.04 < W \leq 0.06$	4	4																											
$L \leq 2.0$	$0.06 < W \leq 0.08$	2	3																											
—	$0.08 < W \leq 0.1$	0	1																											
3	Air Bubbles (between glass & polarizer)	<table border="1"> <thead> <tr> <th rowspan="2">Zone Dimension</th> <th colspan="2">Acceptable number</th> <th rowspan="2">Class of Defects</th> <th rowspan="2">AQL Level</th> </tr> <tr> <th>A</th> <th>B</th> </tr> </thead> <tbody> <tr> <td>$D \leq 0.15$</td> <td>*</td> <td>*</td> <td rowspan="3">Minor</td> <td rowspan="3">2.5</td> </tr> <tr> <td>$0.15 < D \leq 0.25$</td> <td>2</td> <td>*</td> </tr> <tr> <td>$0.25 < D \leq 0.3$</td> <td>0</td> <td>1</td> </tr> </tbody> </table> <p style="text-align: center;">* : Disregard Total defects shall not excess 3/module.</p>	Zone Dimension	Acceptable number		Class of Defects	AQL Level	A	B	$D \leq 0.15$	*	*	Minor	2.5	$0.15 < D \leq 0.25$	2	*	$0.25 < D \leq 0.3$	0	1										
Zone Dimension	Acceptable number			Class of Defects	AQL Level																									
	A	B																												
$D \leq 0.15$	*	*	Minor	2.5																										
$0.15 < D \leq 0.25$	2	*																												
$0.25 < D \leq 0.3$	0	1																												
4	Uniformity of Pixel	<p>(1) Pixel shape (with Dent)</p> 																												

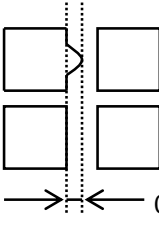
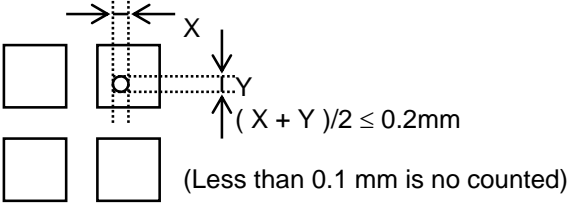
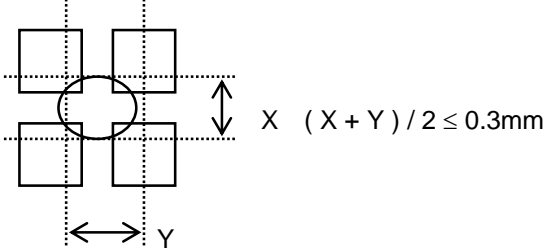
4	Uniformity of Pixel	(2) Pixel shape (with Projection)  Should not be connected to next pixel 0.152	
		(3) Pin hole  (Less than 0.1 mm is no counted)	
		(4) Deformation  X (X + Y) / 2 ≤ 0.3mm	
		Total acceptable number : 1/pixel, 5/cell	
Class of defects	Major	AQL 0.65	Definition It is a defect that is likely to result in failure or to reduce materially the usability of the product for the intended function.
		AQL 1.00	It is a defect that is likely to assembly size and not result in functioning problem.
	Minor	AQL 2.5	It is a defect that will not result in functioning problem with deviation classified.

11.3 Sampling Condition

Unless otherwise agree in written, the sampling inspection shall be applied to the incoming inspection of customer.

Lot size: Quantity of shipment lot per model.

Sampling type: normal inspection, single sampling

Sampling table: ISO2859

Inspection level: Level II

12. LOT NUMBERING SYSTEM

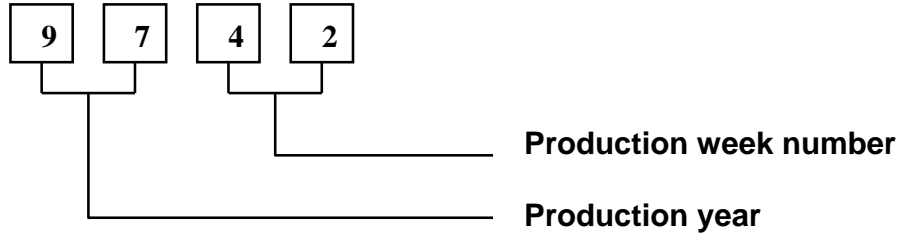

13. LCM NUMBERING SYSTEM

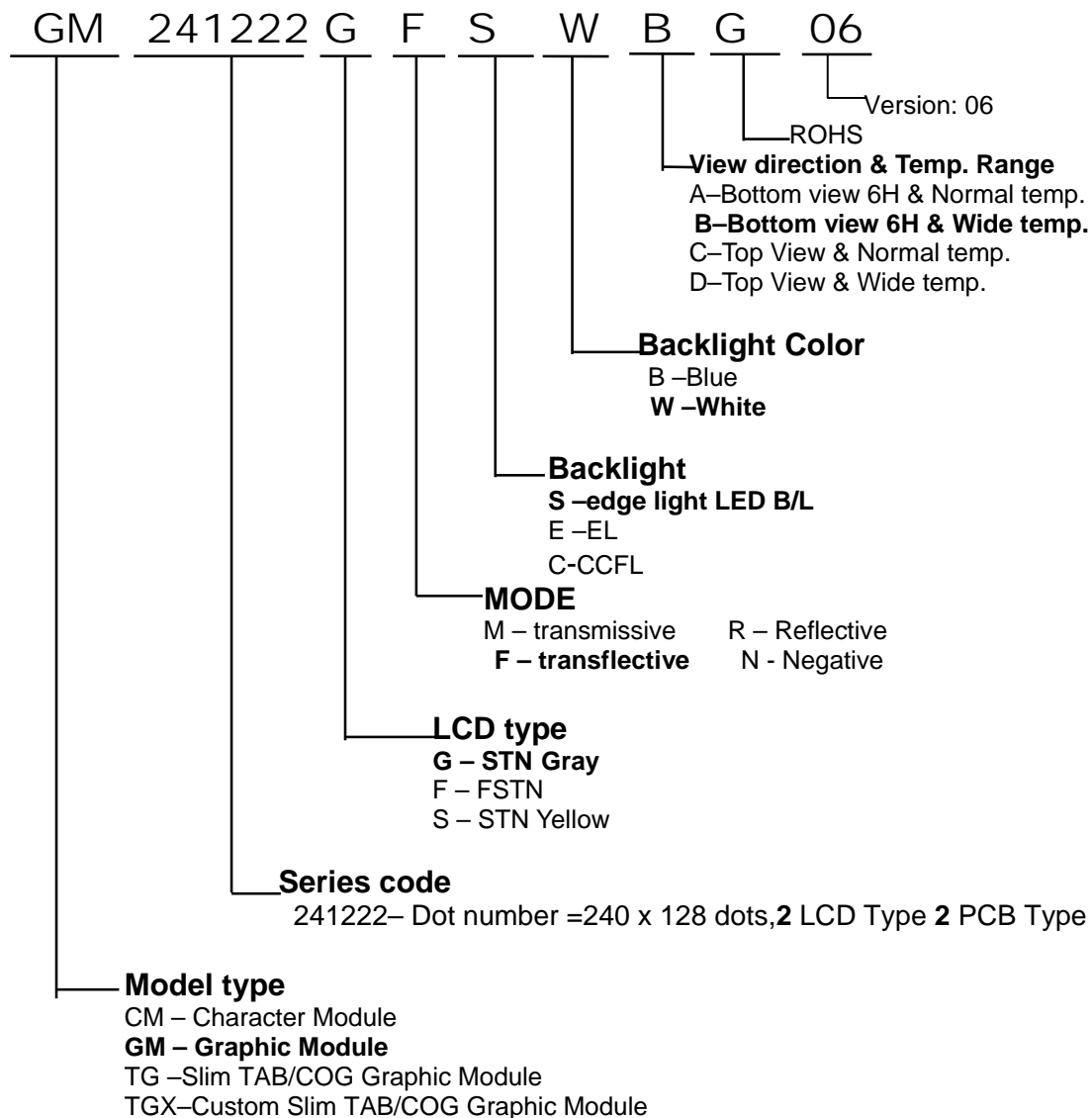

14. PRECAUTIONS IN USE LCM

1. LIQUID CRYSTAL DISPLAY (LCD)

LCD is made up of glass, organic sealant, organic fluid, and polymer based polarizers. The following precautions should be taken when handling,

- (1). Keep the temperature within range of use and storage. Excessive temperature and humidity could cause polarization degradation, polarizer peel off or bubble.
- (2). Do not contact the exposed polarizers with anything harder than an HB pencil lead. To clean dust off the display surface, wipe gently with cotton, chamois or other soft material soaked in petroleum benzin.
- (3). Wipe off saliva or water drops immediately. Contact with water over a long period of time may cause polarizer deformation or color fading, while an active LCD with water condensation on its surface will cause corrosion of ITO electrodes.
- (4). Glass can be easily chipped or cracked from rough handling, especially at corners and edges.
- (5). Do not drive LCD with DC voltage.

2. Liquid Crystal Display Modules

2.1 Mechanical Considerations

LCM are assembled and adjusted with a high degree of precision. Avoid excessive shocks and do not make any alterations or modifications. The following should be noted.

- (1). Do not tamper in any way with the tabs on the metal frame.
- (2). Do not modify the PCB by drilling extra holes, changing its outline, moving its components or modifying its pattern.
- (3). Do not touch the elastomer connector, especially insert an backlight panel (for example, EL).
- (4). When mounting a LCM make sure that the PCB is not under any stress such as bending or twisting. Elastomer contacts are very delicate and missing pixels could result from slight dislocation of any of the elements.
- (5). Avoid pressing on the metal bezel, otherwise the elastomer connector could be deformed and lose contact, resulting in missing pixels.

2.2. Static Electricity

LCM contains CMOS LSI's and the same precaution for such devices should apply, namely

- (1). The operator should be grounded whenever he/she comes into contact with the module. Never touch any of the conductive parts such as the LSI pads, the copper leads on the PCB and the interface terminals with any parts of the human body.
- (2). The modules should be kept in antistatic bags or other containers resistant to static for storage.
- (3). Only properly grounded soldering irons should be used.
- (4). If an electric screwdriver is used, it should be well grounded and shielded from commutator sparks.

(5) The normal static prevention measures should be observed for work clothes and working benches; for the latter conductive (rubber) mat is recommended.

(6). Since dry air is inductive to static, a relative humidity of 50-60% is recommended.

2.3 Soldering

- (1). Solder only to the I/O terminals.
- (2). Use only soldering irons with proper grounding and no leakage.
- (3). Soldering temperature : $280^{\circ}\text{C} \pm 10^{\circ}\text{C}$
- (4). Soldering time: 3 to 4 sec.
- (5). Use eutectic solder with resin flux fill.
- (6). If flux is used, the LCD surface should be covered to avoid flux spatters. Flux residue should be removed after wards.

2.4 Operation

- (1). The viewing angle can be adjusted by varying the LCD driving voltage V_0 .
- (2). Driving voltage should be kept within specified range; excess voltage shortens display life.
- (3). Response time increases with decrease in temperature.
- (4). Display may turn black or dark blue at temperatures above its operational range; this is (however not pressing on the viewing area) may cause the segments to appear "fractured".
- (5). Mechanical disturbance during operation (such as pressing on the viewing area) may cause the segments to appear "fractured".

2.5 Storage

If any fluid leaks out of a damaged glass cell, wash off any human part that comes into contact with soap and water. Never swallow the fluid. The toxicity is extremely low but caution should be exercised at all the time.

2.6 Limited Warranty

Unless otherwise agreed between DATA IMAGE and customer, DATA IMAGE will replace or repair any of its LCD and LCM which is found to be defective electrically and visually when inspected in accordance with DATA IMAGE acceptance standards, for a period on one year from date of shipment. Confirmation of such date shall be based on freight documents. The warranty liability of DATA IMAGE is limited to repair and/or replacement on the terms set forth above. DATA IMAGE will not responsible for any subsequent or consequential events.

16. PACKAGE INFORMATION

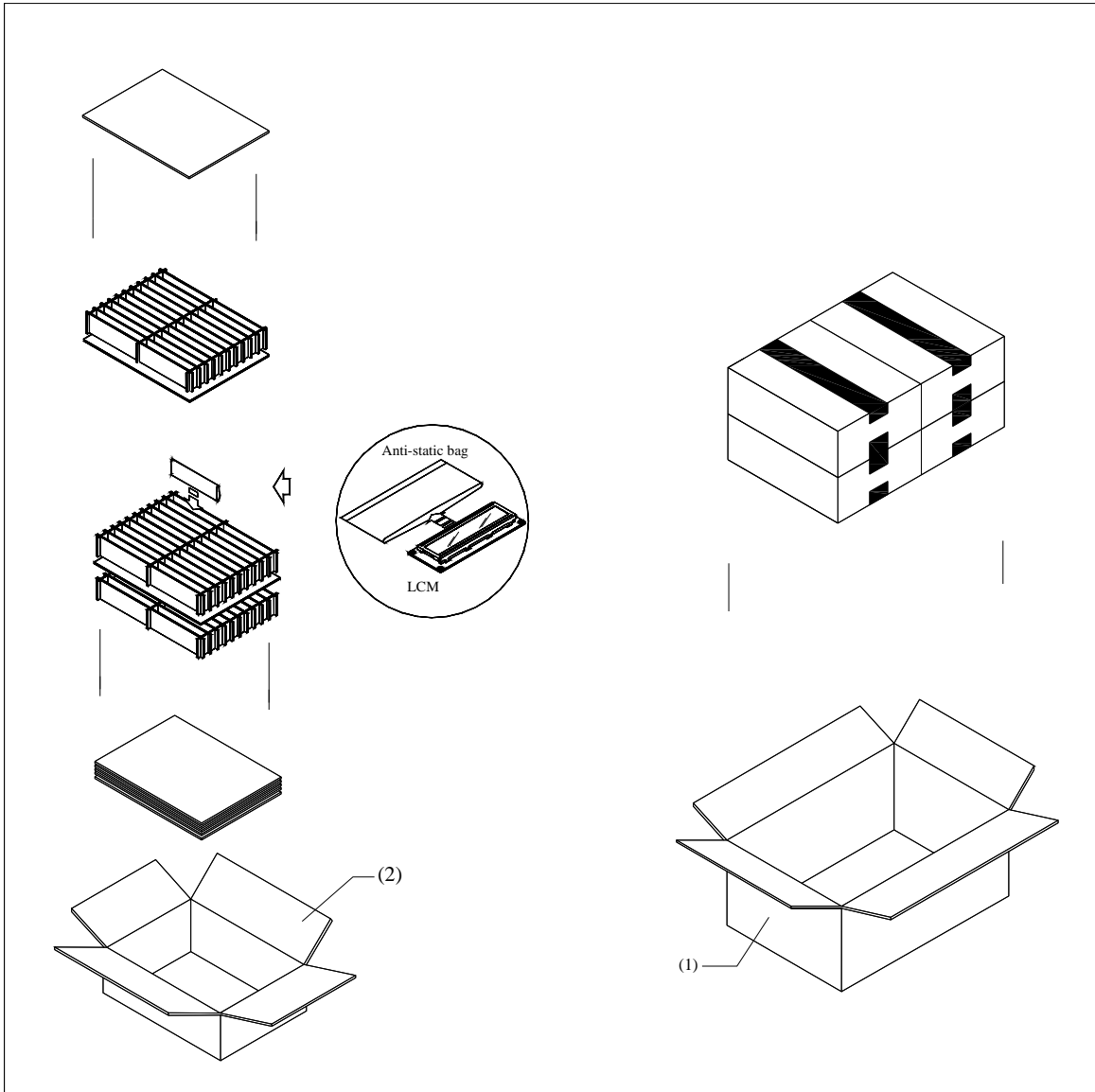

Item	Size(L*W*H)	Quantity	Note
1.Master Carton	482*282*355	1	
2.Inner Carton	267*224*150	4	
Quantity Per Inner Carton	12	Quantity Per Master Carton	48
N . W	12 (kg)	G . W	13 (kg)