



DATA IMAGE CORPORATION

LCD Module Specification

ITEM NO.: GM241200FNCWAG03

Table of Contents

- 1. COVER & CONTENTS 1
- 2. RECORD OF REVISION 2
- 3. GENERAL SPECIFICATIONS 3
- 4. ABSOLUTE MAXIMUM RATINGS 4
- 5. ELECTRICAL CHARACTERISTICS 6
- 6. ELECTRO-OPTICAL CHARACTERISTIC 6
- 7. TIMING CHARACTERISTICS 9
- 8. PIN CONNECTIONS 10
- 9. POWER SUPPLY 10
- 10. BLOCK DIAGRAM 11
- 11. QUALITY ASSURANCE 16
- 12. LOT NUMBERING SYSTEM 20
- 13. LCM NUMBERING SYSTEM 20
- 14. PRECAUTIONS IN USE LCM 21
- 15. OUTLINE DRAWING 22
- 16. PACKAGE INFORMATION 23

Customer Companies	R&D Dept.	Q.C. Dept.	Eng. Dept.	Prod. Dept.
	<i>Jack</i>	<i>Eric</i>	<i>Iden</i>	<i>heien</i>
Approved by	Version:	Issued Date:	Sheet Code:	Total Pages:
	A	2006/6/13		23

3. GENERAL SPECIFICATION

Display Format : 240 (W) × 128 (H) dots
 Dots Size : 0.47 (W) × 0.47 (H) mm
 View Area : 128.0 (W) × 74.0 (H) mm
 General Dimensions : 170 (W) × 103.2 (H) × 12.0 (T) mm Max.

Weight : 250 g max.

LCD Type & Background Color: STN Blue STN Yellow FSTN Dark Black

Polarizer mode : Reflective Transflective

Transmissive Negative

View Angle : 6 O'clock 12 O'clock Others _____

Backlight : LED EL CCFL

Backlight Color : Yellow green Amber Blue Green

White Others

Controller / Driver : T6963C

Temperature Range : Normal Wide Temperature
 Operating 0 to 50°C Operating -20 to 70°C
 Storage -20 to 70°C Storage -30 to 80°C

Pixel Color: White

REMARK:

Our components and processes are compliant to RoHS standard.

4. ABSOLUTE MAXIMUM RATINGS

4.1 ELECTRICAL ABSOLUTE MAXIMUM RATINGS

V_{SS}= 0V, Ta = 25°C

Item	Symbol	Min.	Max.	Unit
Supply Voltage (Logic)	V _{DD-VSS}	-0.3	7	V
Supply Voltage (LCD Driver)	V _{DD-Vo}	0	30	V
Input Voltage	V _I	-0.3	V _{DD} +0.3	V
Operating Temperature	T _{OP}	0	50	°C
Storage Temperature	T _{STG}	-20	70	°C

4.2 ENVIRONMENTAL ABSOLUTE MAXIMUM RATINGS

Item	Operating		Storage		Comment
	(Min.)	Max.)	(Min.)	(Max.)	
Ambient Temp	0	50	-20	70	Note (1)
Humidity	Note (2)		Note(2)		Without Condensation
Vibration	--	4.9M/S ²	--	19.6M/S ²	XYZ Direction
Shock	--	29.4M/S ²	--	490M/S ²	XYZ Direction

Note(1) Ta = 0°C : 50Hr Max.

Note(2) Ta ≤ 40°C : 90% RH Max.

Ta ≥ 40°C : Absolute humidity must be lower than the humidity of 90% RH at 40°C.

4. 3 Electronic Static Discharge maximum rating

ESD test method : IEC1000-4-2

Item	Description
Testing environment	Ambient temperature :15°C to 35 °C Humidity: 30% to 60 % LCM (E.U.T) : Power up
Testing equipment	Manufacture: Noise Ken, Model No. ESD-100L
Testing condition	See drawing 1
Direct discharge	0 to ± 6 KV Discharge point, see drawing 2
Indirect discharge	0 to ± 12KV Discharge point, see drawing 1
Pass condition	No malfunction of unit. Temporary malfunction of unit which can be recovered by system reset
Fail condition	Non. Recoverable malfunction of LCM or system

FIG 1 ESD TESTING EQUIPMENT

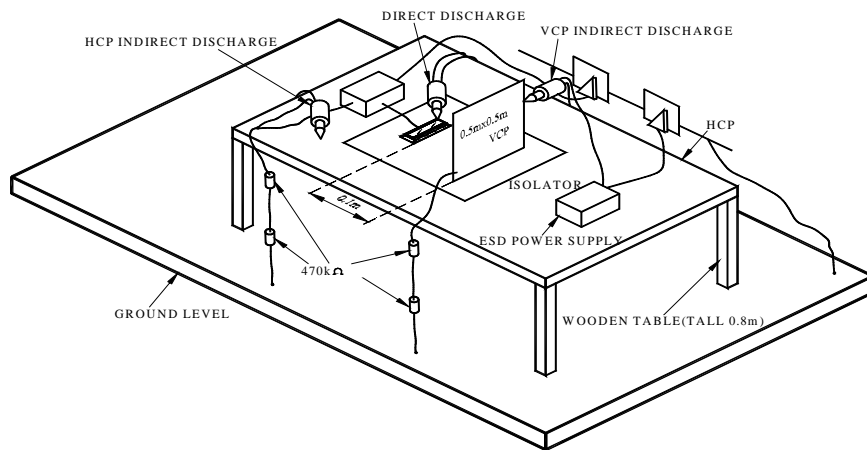

(1)

DIRECT CONTACT DISCHARGE

CONTACT POINT : A.B.C.D

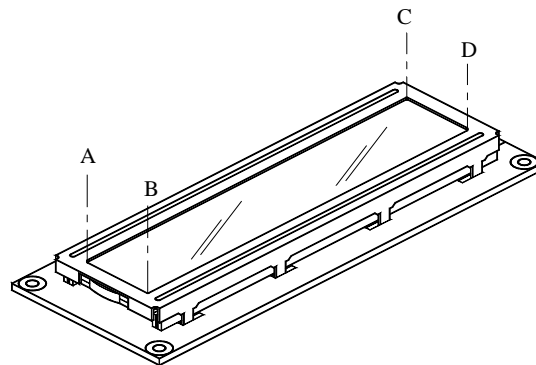

(2)

5. ELECTRICAL CHARACTERISTICS

Item	Symbol	Condition	Min.	Typ.	Max.	Unit
Supply Voltage (Logic)	VDD-VSS		4.5	5.0	5.5	V
Supply Voltage (LCD)	VDD-VO	0°C	18.9	19.9	20.8	V
		25°C	17.4	18.5	19.4	
		50°C	15.5	16.3	17.6	
Input Voltage	V _{IH}	--	VDD-2.2	--	VDD	V
	V _{IL}		0	--	0.8	
Logic Supply Current	I _{DD}	VDD-VSS=5V	--	4.78	--	mA
	I _{EE}		--	--	--	mA

6. ELECTRO-OPTICAL CHARACTERISTICS

ITEM	Symbol	Condition	Min.	Typ.	Max.	Unit	Ref.
Rise Time	Tr	0°C	--	500	750	ms	Note (1)
		25°C		120	180		
Fall Time	Tf	0°C	--	700	1100	ms	
		25°C		140	210		
Contrast	CR	25°C	--	15	--		Note (3)
View Angle	θ _{1~θ2} ∅ _{1, ∅2}	25°C & CR≥3	--	90	--		Note (2)
			--	±40	--		
Frame Frequency	Ff	25°C	--	70	--	Hz	

Note (1) & (2) : See next page

Note (3) : Contrast ratio is defined under the following condition:

$$CR = \frac{\text{Brightness of non-selected condition}}{\text{Brightness of selected condition}}$$

- (a). Temperature ----- 25°C
- (b). Frame frequency ---- 70Hz
- (c). Viewing angle ----- θ= 0°, ∅ = 0°
- (d). Operating voltage --- 18.5V

Note (1) Response time is measured as the shortest period of time possible between the change in state of an LCD segment as demonstrated below:

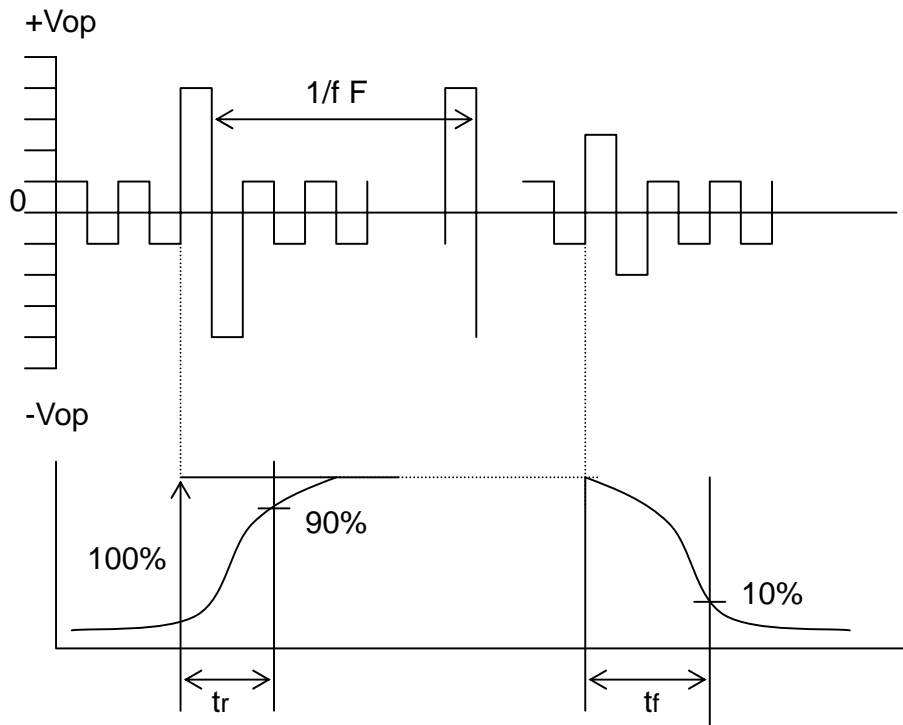

Condition:

- (a) . Temperature -----25°C
- (b) . Frame frequency ----- 70Hz
- (c) . View Angle ----- $\theta = 0^\circ, \varnothing=0^\circ$
- (d) . Operating voltage ----- 18.5V

Note (2) Definition of View Angle

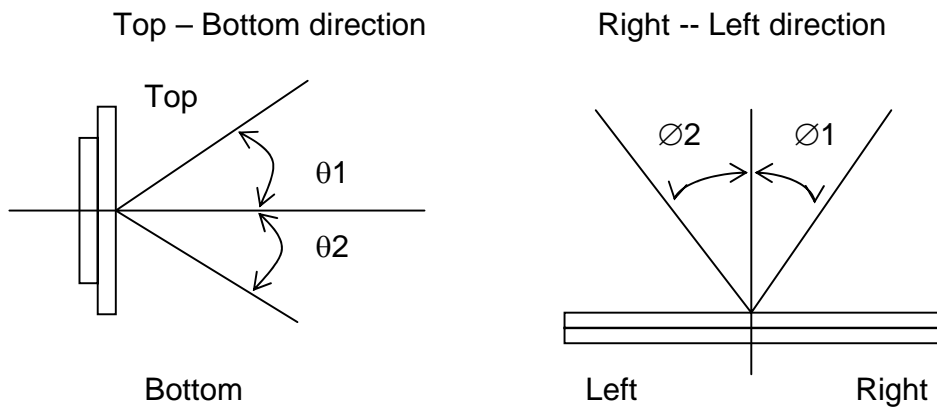

6.1 CCFL ELECTRICAL CHARACTERISTIC

Item	Condition
Start Voltage	1110 Vrms max, at Ta=0°C 880 Vrms max, at Ta=25°C
Tube Voltage	372±10%Vrms, at Ta=25°C
Tube Current	5.0m Arms typ , at Ta=25°C
Drive Frequency	35±5 KHz , typ at Ta=25°C

6.1.2 Intitial Optical Characteristics

Item	Condition	
Brightness Uniformity	75% min.	
Average Brightness	500 cd/m ² min.	
Chromaticity	X	0.33±0.02
	Y	0.37±0.02

6.1.3 Environmental Conditions

Item	Temperature	Humidity	Unit
Operating	0 to 50°C	20 to 90%	RH
Storage	-20 to 70°C	5 to 90%	RH

Recommend CCFL inverter:
TDK 347-3

7. TIMING CHARACTERISTICS

- Switching Characteristics (2)
Bus Timing

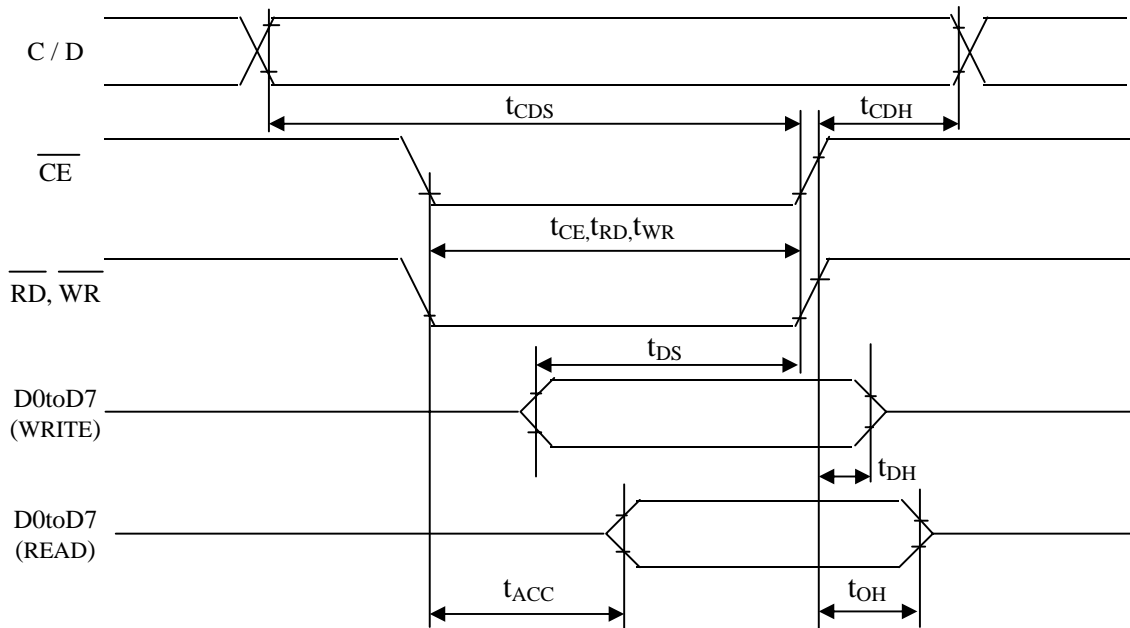

TEST CONDITIONS (Unless otherwise noted. $V_{DD} = 5.0V \pm 10\%$, $V_{SS} = 0V$, $T_a = -20$ to 75)

ITEM	SYMBOL	TEST CONDITIONS	MIN	MAX	UNIT
C / D Set-up Time	t_{CDS}	--	100	--	ns
C / D Hold Time	t_{CDH}	--	10	--	ns
CE, RD, WR Pulse Width	t_{CE}, t_{RD}, t_{WR}	--	80	--	ns
Data Set-up Time	t_{DS}	--	80	--	ns
Data Hold Time	t_{DH}	--	40	--	ns
Access Time	t_{ACC}	--	--	150	ns
Output Hold Time	t_{OH}	--	10	50	ns

8. PIN CONNECTIONS

Pin	Symbol	Function
1	FGND	Frame Ground (Connect to Bezel)
2	V _{SS}	Ground Potential (Logic)
3	V _{DD}	Power Supply (+5V)
4	V _O	Power Supply Input for LCD (-V)
5	/WR	Data Write
6	/RD	Data Read
7	/CE	Chip Enable
8	C/D	Code / Data
9	N.C	No Connection
10	/RST	Reset, Active LOW
11	DB0	Data Bus Line
12	DB1	
13	DB2	
14	DB3	
15	DB4	
16	DB5	
17	DB6	
18	DB7	
19	FS	Font Select, L = 8 × 8, H = 8 × 6
20	RV	Reverse Data

9. POWER SUPPLY

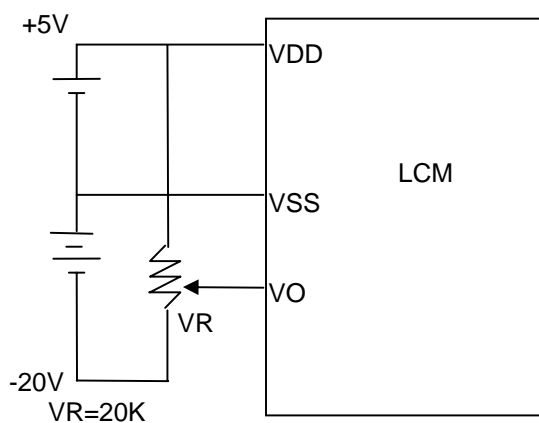

10. BLOCK DI AGRAM

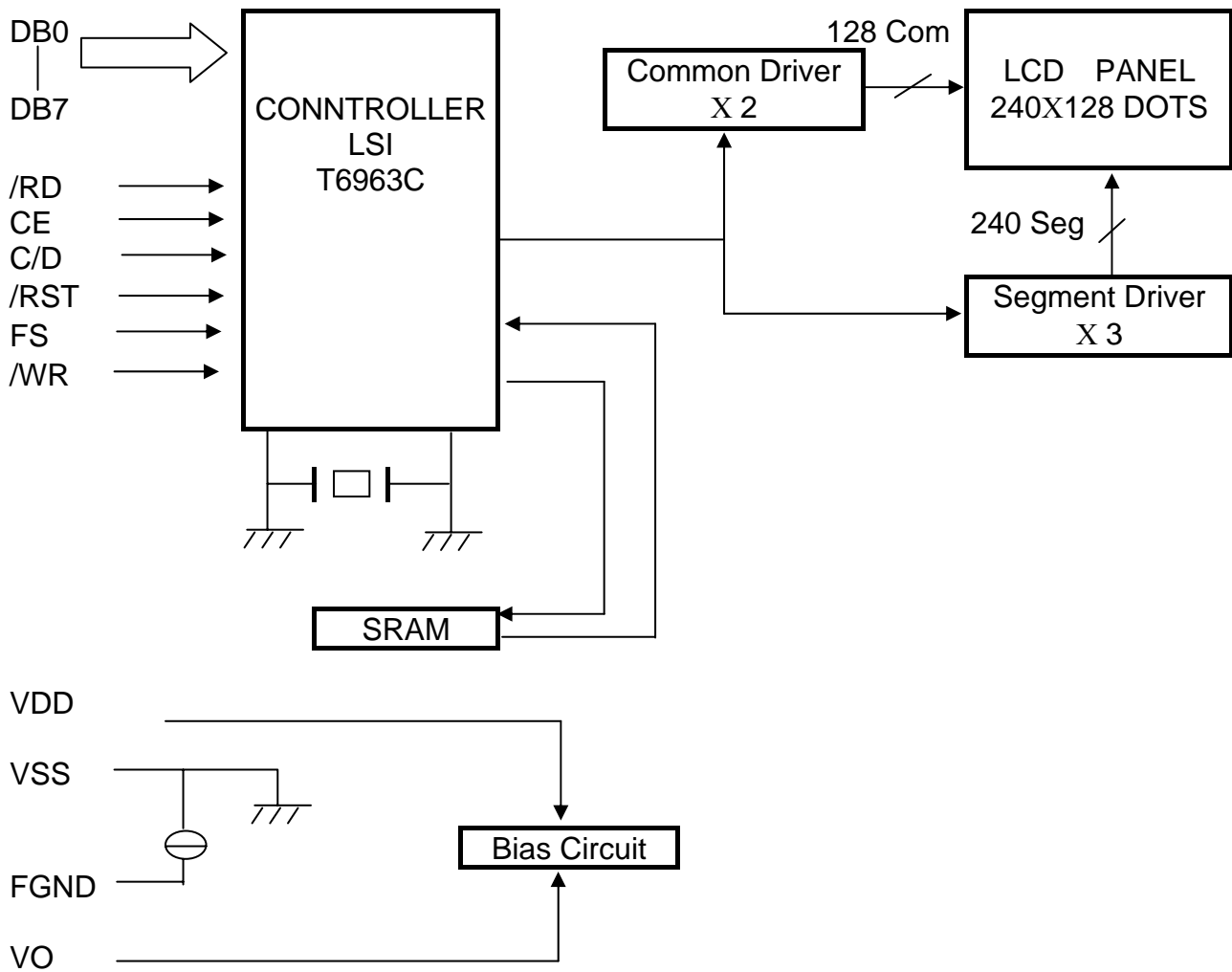

• Flowchart of communications with MPU

(1) Status Read

A status check must be performed before data is read or written.

Status check

The Status of T6963C can be read from the data lines.

\overline{RD}	L
\overline{WR}	H
\overline{CE}	L
C / D	H
D0 to D7	Status word

The T6963C status word format is as follows:

MSB				LSB			
STA7 D7	STA6 D6	STA5 D5	STA4 D4	STA3 D3	STA2 D2	STA1 D1	STA0 D0
STA0	Check command execution capability		0 : Disable 1 : Enable				
STA1	Check data read / write capability		0 : Disable 1 : Enable				
STA2	Check Auto mode data read capability		0 : Disable 1 : Enable				
STA3	Check Auto mode data write capability		0 : Disable 1 : Enable				
STA4	Not used						
STA5	Check controller operation capability		0 : Disable 1 : Enable				
STA6	Error flag. Used for Screen Peek and Screen copy commands.		0 : No error 1 : Error				
STA7	Check the blink condition		0 : Display off 1 : Normal display				

- (Note 1) It is necessary to check STA0 and STA1 at the same time.
There is a possibility of erroneous operation due to a hardware interrupt.
- (Note 2) For most modes STA0 / STA1 are used as a status check.
- (Note 3) STA2 and STA3 are valid in Auto mode; STA0 and STA1 are invalid.

Status checking flow

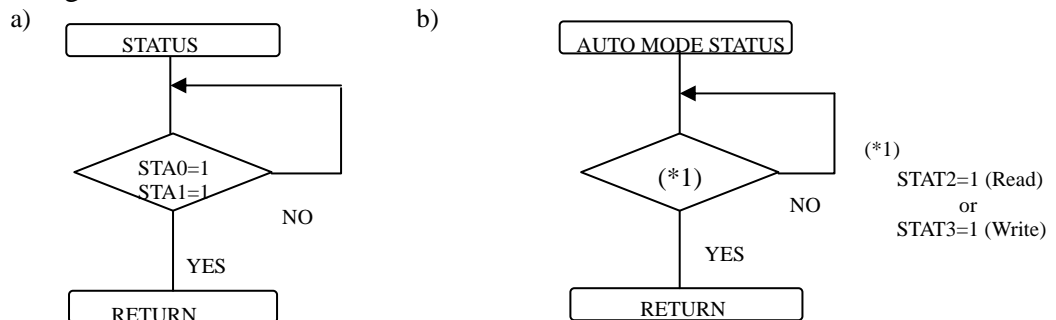

- (Note 4) When using the MSB = 0 command, a Status Read must be performed.
If a status check is not carried out, the T6963C cannot operate normally, even after a delay time.
The hardware interrupt occurs during the address calculation period (at the end of each line).
If a MSB = 0 command is sent to the T6963C during this period, the T6963C enters Wait status.
If a status check is not carried out in this state before the next command is sent, there is the Possibility that the command or data will not be received.

(2) Setting data

When using the T6963C, first set the data, then set the command.

Procedure for sending a command

a) The case of 1 data

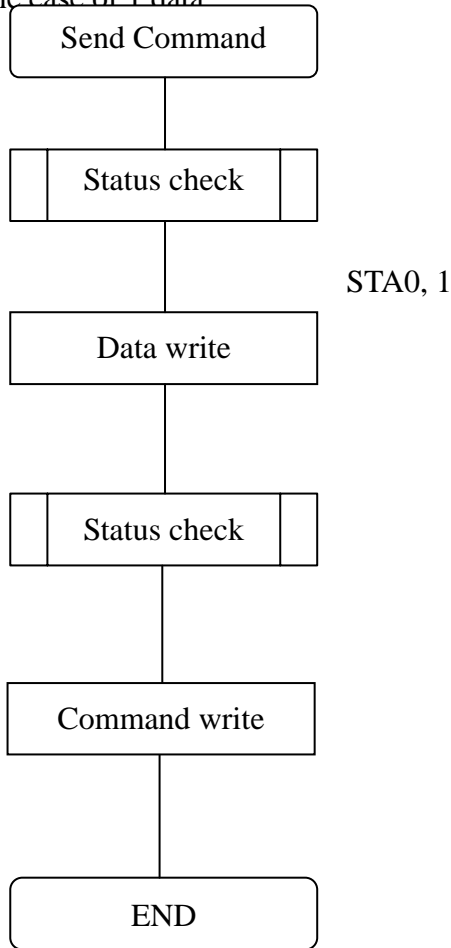

b) The case of 2 data

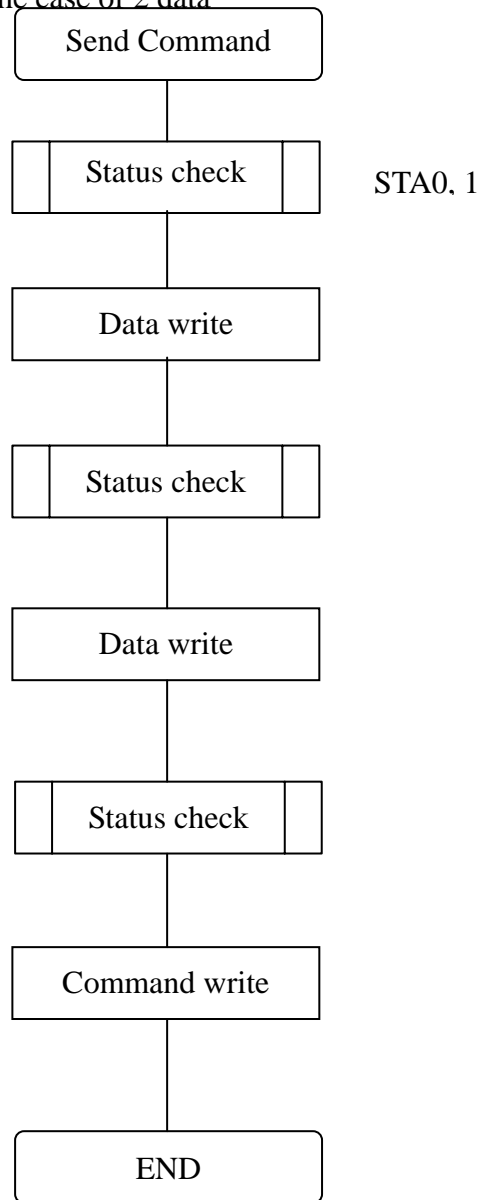

(Note) When sending more than two data, the last datum (or last two data) is valid.

COMMAND DEFINITIONS

COMMAND	CODE	D1	D2	FUNCTION
REGISTERS SETTING	00100001 00100010 00100100	X address Data Low address	Y address 00H High address	Set Cursor Pointer Set Offset Register Set Address Pointer
SET CONTROL WORD	01000000 01000001 01000010 01000011	Low address Columns Low address Columns	High address 00H High address 00H	Set Text Home Address Set Text Area Set Graphic Home Address Set Graphic Area
MODE SET	1000X000 1000X001 1000X011 1000X100 10000XXX 10001XXX	— — — — — —	— — — — — —	OR mode EXOR mode AND mode Text Attribute mode Internal CG ROM mode External CG RAM mode
DISPLAY MODE	10010000 1001XX10 1001 XX11 100101 XX 100110 XX 100111 XX	— — — — — —	— — — — — —	Display off Cursor on, blink off Cursor on, blink on Text on, graphic off Text off, graphic on Text on, graphic on
CURSOR PATTERN SELECT	10100000 10100001 10100010 10100011 10100100 10100101 10100110 10100111	— — — — — — — —	— — — — — — — —	1-line cursor 2-line cursor 3-line cursor 4-line cursor 5-line cursor 6-line cursor 7-line cursor 8-line cursor
DATA AUTO READ / WRITE	10110000 10110001 10110010	— — —	— — —	Set Data Auto Write Set Data Auto Read Auto Reset
DATA READ / WRITE	11000000 11000001 11000010 11000011 11000100 11000101	Data — Data — Data —	— — — — — —	Data Write and Increment ADP Data Read and Increment ADP Data Write and Decrement ADP Data Read and Decrement ADP Data Write and Nonvariable ADP Data Read and Nonvariable ADP
SCREEN PEEK	11100000	—	—	Screen Peek
SCREEN COPY	11101000			Screen Copy
BIT SET / RESET	11110XXX 11111XXX 1111X000 1111X001 1111X010 1111X011 1111X100 1111X101 1111X110 1111X111	— — — — — — — — — —	— — — — — — — — — —	Bit Reset Bit Set Bit 0 (LSB) Bit 1 Bit 2 Bit 3 Bit 4 Bit 5 Bit 6 Bit 7 (MSB)

X : invalid

- Setting registers

CODE	HEX.	FUNCTION	D1	D2
00100001	21H	SET CURSOR POINTER	X ADRS	Y ADRS
00100010	22H	SET OFFSET REGISTER	DATA	00H
00100100	24H	SET ADDRESS POINTER	LOW ADRS	HIGH ADRS

(1) Set Cursor Pointer

The position of the cursor is specified by X ADRS and Y ADRS. The cursor position can only be moved by this command. Data read / write from the MPU never changes the cursor pointer. X ADRS and Y ADRS are specified as follows.

X ADRS 00H to 4FH (lower 7 bits are valid)

Y ADRS 00H to 1FH (lower 5 bits are valid)

a) Single – Scan

X ADRS 00 to 4FH

Y ADRS 00H to 0FH

b) Dual – Scan

X ADRS 00 to 4FH

Y ADRS 00H to 0FH Upper screen

Y ADRS 00H to 1FH Lower screen

(2) Set Offset Register

The offset register is used to determine the external character generator RAM area. The T6963C has a 16-bit address bus as follows:

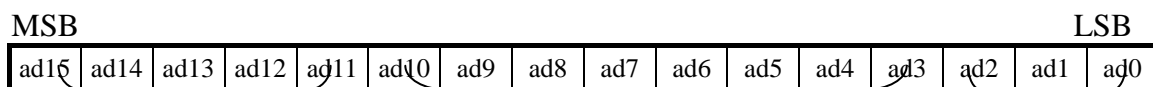

Offset Register Data

Character Code

Line Scan

11. QUALITY ASSURANCE

11.1 Test Condition

11.1.1 Temperature and Humidity(Ambient Temperature)

Temperature : $20 \pm 5^{\circ}\text{C}$

Humidity : $65 \pm 5\%$

11.1.2 Operation

Unless specified otherwise, test will be conducted with LCM in operation.

11.1.3 Container

Unless specified otherwise, vibration test will be conducted on module only.

11.1.4 Test Frequency

Single cycle.

11.1.5 Test Method

No.	Parameter	Conditions	Regulations
1	High Temperature Operating	$50 \pm 2^{\circ}\text{C}$	Note 3
2	Low Temperature Operating	$0 \pm 2^{\circ}\text{C}$	Note 3
3	High Temperature Storage	$70 \pm 2^{\circ}\text{C}$	Note 3
4	Low Temperature Storage	$-20 \pm 2^{\circ}\text{C}$	Note 3
5	Vibration Test (Non-operation state)	Total fixed amplitude : 1.5mm Vibration Frequency : 10 ~ 55Hz One cycle 60 seconds to 3 directions of X.Y.Z. for each 15 minutes	Note 3
6	Damp Proof Test (Non-operation state)	$40^{\circ}\text{C} \pm 2^{\circ}\text{C}$, 90~95%RH, 96h	Note 1,2
7	Shock Test (Non-operation state)	To be measured after dropping from 60cm high once concrete surface in packing state	Note 3

Note 1: Returned under normal temperature and humidity for 4 hrs.

Note 2: No dew condensation to be observed.

Note 3: No change on display and in operation under the test condition

11.2 Inspection condition

11.2.1 Inspection conditions

The LCD shall be inspected under 40W white fluorescent light.

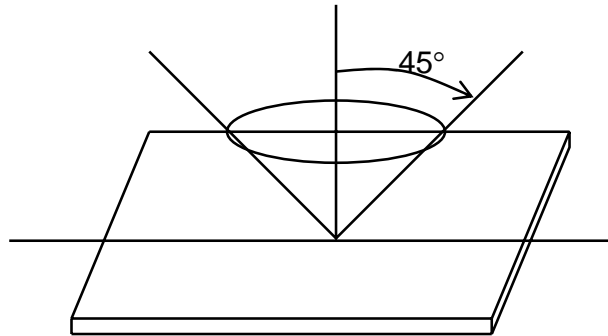

11.2.2 Definition of applicable Zones

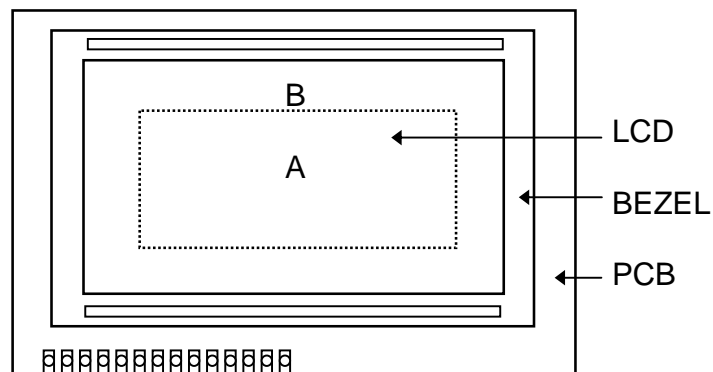

A : Display Area
B : Non-Display Area

11.2.3 Inspection Parameters

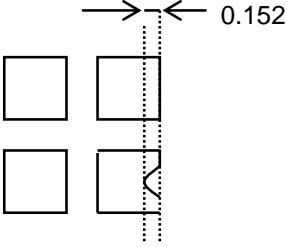
No.	Parameter	Criteria																																	
1	Black or White spots	<table border="1"> <thead> <tr> <th rowspan="2">Zone Dimension</th> <th colspan="2">Acceptable number</th> <th rowspan="2">Class Of Defects</th> <th rowspan="2">AQL Level</th> </tr> <tr> <th>A</th> <th>B</th> </tr> </thead> <tbody> <tr> <td>$D < 0.15$</td> <td>*</td> <td>*</td> <td rowspan="4">Minor</td> <td rowspan="4">2.5</td> </tr> <tr> <td>$0.15 \leq D < 0.2$</td> <td>4</td> <td>4</td> </tr> <tr> <td>$0.2 \leq D \leq 0.25$</td> <td>2</td> <td>2</td> </tr> <tr> <td>$D \leq 0.3$</td> <td>0</td> <td>1</td> </tr> </tbody> </table> <p style="text-align: center;">$D = (\text{Long} + \text{Short}) / 2$ * : Disregard</p>	Zone Dimension	Acceptable number		Class Of Defects	AQL Level	A	B	$D < 0.15$	*	*	Minor	2.5	$0.15 \leq D < 0.2$	4	4	$0.2 \leq D \leq 0.25$	2	2	$D \leq 0.3$	0	1												
Zone Dimension	Acceptable number			Class Of Defects	AQL Level																														
	A	B																																	
$D < 0.15$	*	*	Minor	2.5																															
$0.15 \leq D < 0.2$	4	4																																	
$0.2 \leq D \leq 0.25$	2	2																																	
$D \leq 0.3$	0	1																																	
2	Scratch, Substances	<table border="1"> <thead> <tr> <th rowspan="2">X (mm) \ Y (mm)</th> <th colspan="2">Zone</th> <th colspan="2">Acceptable number</th> <th rowspan="2">Class Of Defects</th> <th rowspan="2">AQL Level</th> </tr> <tr> <th></th> <th></th> <th>A</th> <th>B</th> </tr> </thead> <tbody> <tr> <td>*</td> <td>$0.04 \geq W$</td> <td></td> <td>*</td> <td>*</td> <td rowspan="4">Minor</td> <td rowspan="4">2.5</td> </tr> <tr> <td>$3.0 \geq L$</td> <td>$0.06 \geq W$</td> <td></td> <td>4</td> <td>4</td> </tr> <tr> <td>$2.0 \geq L$</td> <td>$0.08 \geq W$</td> <td></td> <td>2</td> <td>3</td> </tr> <tr> <td>—</td> <td>$0.1 < W$</td> <td></td> <td>0</td> <td>1</td> </tr> </tbody> </table> <p>X : Length Y : Width * : Disregard Total defects should not exceed 4/module</p>	X (mm) \ Y (mm)	Zone		Acceptable number		Class Of Defects	AQL Level			A	B	*	$0.04 \geq W$		*	*	Minor	2.5	$3.0 \geq L$	$0.06 \geq W$		4	4	$2.0 \geq L$	$0.08 \geq W$		2	3	—	$0.1 < W$		0	1
X (mm) \ Y (mm)	Zone			Acceptable number		Class Of Defects	AQL Level																												
			A	B																															
*	$0.04 \geq W$		*	*	Minor	2.5																													
$3.0 \geq L$	$0.06 \geq W$		4	4																															
$2.0 \geq L$	$0.08 \geq W$		2	3																															
—	$0.1 < W$		0	1																															
3	Air Bubbles (between glass & polarizer)	<table border="1"> <thead> <tr> <th rowspan="2">Zone Dimension</th> <th colspan="2">Acceptable number</th> <th rowspan="2">Class of Defects</th> <th rowspan="2">AQL Level</th> </tr> <tr> <th>A</th> <th>B</th> </tr> </thead> <tbody> <tr> <td>$D \leq 0.15$</td> <td>*</td> <td>*</td> <td rowspan="3">Minor</td> <td rowspan="3">2.5</td> </tr> <tr> <td>$0.15 < D \leq 0.25$</td> <td>2</td> <td>*</td> </tr> <tr> <td>$0.25 < D$</td> <td>0</td> <td>1</td> </tr> </tbody> </table> <p>* : Disregard Total defects shall not excess 3/module.</p>	Zone Dimension	Acceptable number		Class of Defects	AQL Level	A	B	$D \leq 0.15$	*	*	Minor	2.5	$0.15 < D \leq 0.25$	2	*	$0.25 < D$	0	1															
Zone Dimension	Acceptable number			Class of Defects	AQL Level																														
	A	B																																	
$D \leq 0.15$	*	*	Minor	2.5																															
$0.15 < D \leq 0.25$	2	*																																	
$0.25 < D$	0	1																																	
4	Uniformity of Pixel	<p>(1) Pixel shape (with Dent)</p> 																																	

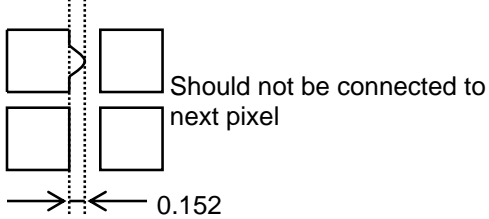
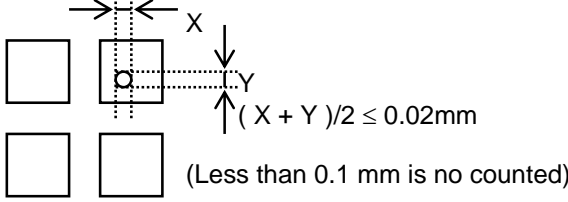
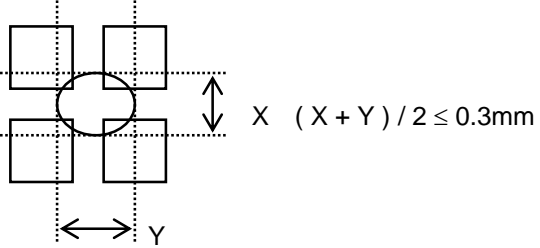
4	Uniformity of Pixel	<p>(2) Pixel shape (with Projection)</p>  <p>Should not be connected to next pixel</p> <p>0.152</p>	
		<p>(3) Pin hole</p>  <p>$(X + Y) / 2 \leq 0.02\text{mm}$</p> <p>(Less than 0.1 mm is no counted)</p>	
		<p>(4) Deformation</p>  <p>$(X + Y) / 2 \leq 0.3\text{mm}$</p> <p>Total acceptable number : 1/pixel, 5/cell</p>	
Class of defects	Major	AQL 0.65%	Definition
		AQL 1.00%	It is a defect that is likely to result in failure or to reduce materially the usability of the product for the intended function.
	Minor	AQL 2.5%	It is a defect that is likely to assembly size and not result in functioning problem.
		It is a defect that will not result in functioning problem with deviation classified.	

11.3 Sampling Condition

Unless otherwise agree in written, the sampling inspection shall be applied to the incoming inspection of customer.

Lot size: Quantity of shipment lot per model.

Sampling type: normal inspection, single sampling

Inspection level: Level II

Sampling table: MIL-STD-105E

12. LOT NUMBERING SYSTEM

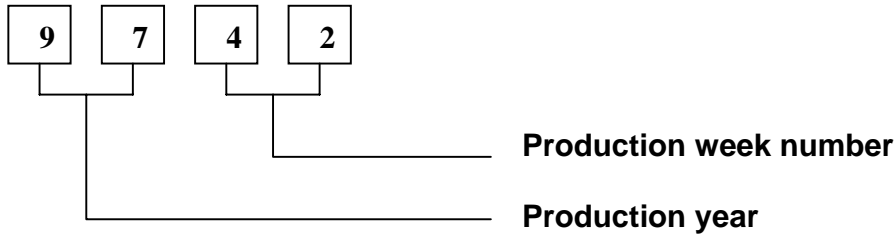

13. LCM NUMBERING SYSTEM

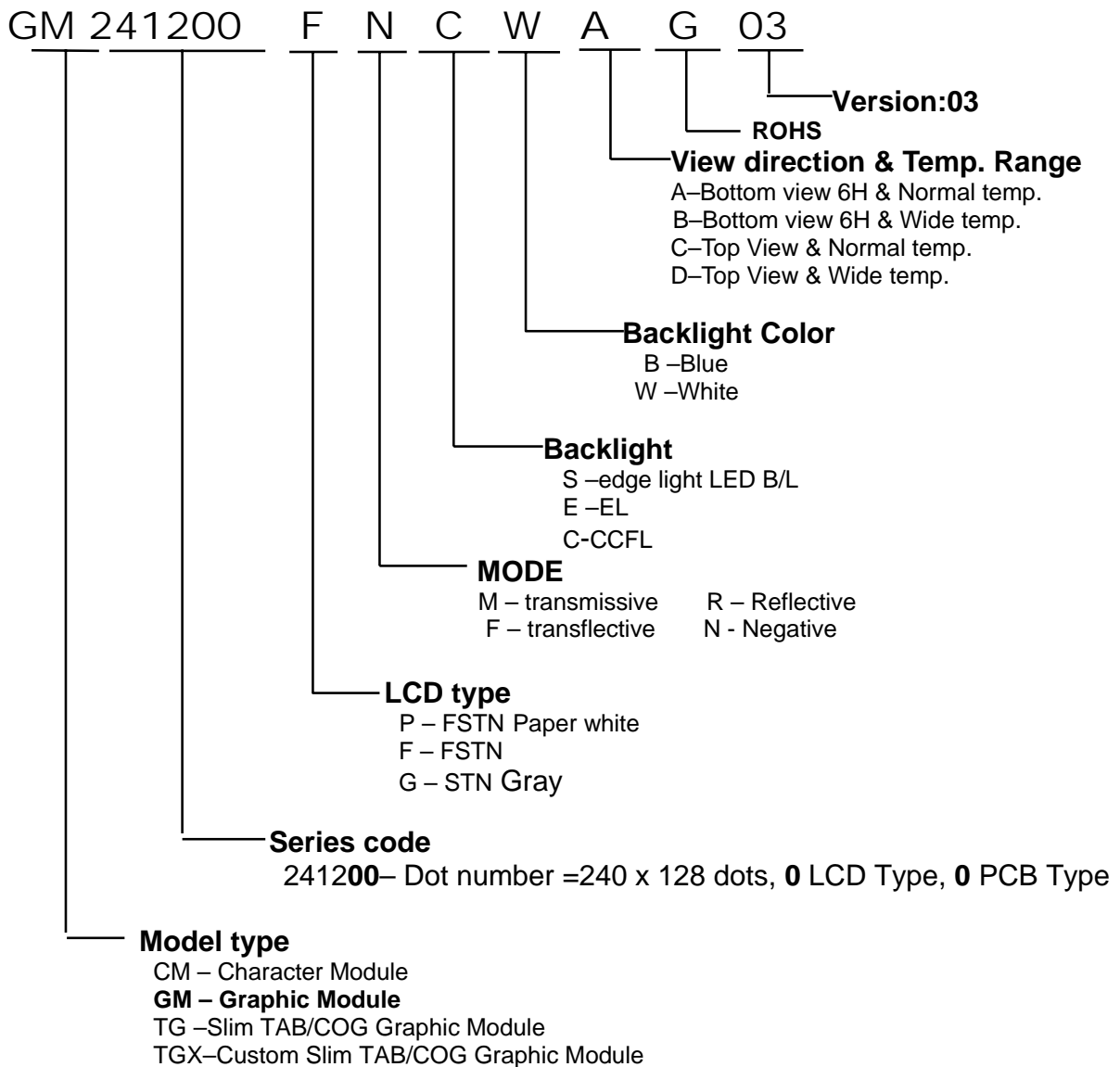

14. PRECAUTION FOR USING LCM

1. LIQUID CRYSTAL DISPLAY (LCD)

LCD is made up of glass, organic sealant, organic fluid, and polymer based polarizers. The following precautions should be taken when handling,

- (1). Keep the temperature within range of use and storage. Excessive temperature and humidity could cause polarization degradation, polarizer peel off or bubble.
- (2). Do not contact the exposed polarizers with anything harder than an HB pencil lead. To clean dust off the display surface, wipe gently with cotton, chamois or other soft material soaked in petroleum benzine.
- (3). Wipe off saliva or water drops immediately. Contact with water over a long period of time may cause polarizer deformation or color fading, while an active LCD with water condensation on its surface will cause corrosion of ITO electrodes.
- (4). Glass can be easily chipped or cracked from rough handling, especially at corners and edges.
- (5). Do not drive LCD with DC voltage.

2. Liquid Crystal Display Modules

2.1 Mechanical Considerations

LCM are assembled and adjusted with a high degree of precision. Avoid excessive shocks and do not make any alterations or modifications. The following should be noted.

- (1). Do not tamper in any way with the tabs on the metal frame.
- (2). Do not modify the PCB by drilling extra holes, changing its outline, moving its components or modifying its pattern.
- (3). Do not touch the elastomer connector, especially insert a backlight panel (for example, EL).
- (4). When mounting a LCM make sure that the PCB is not under any stress such as bending or twisting. Elastomer contacts are very delicate and missing pixels could result from slight dislocation of any of the elements.
- (5). Avoid pressing on the metal bezel, otherwise the elastomer connector could be deformed and lose contact, resulting in missing pixels.

2.2 Static Electricity

LCM contains CMOS LSI's and the same precaution for such devices should apply, namely

- (1). The operator should be grounded whenever he/she comes into contact with the module. Never touch any of the conductive parts such as the LSI pads, the copper leads on the PCB and the interface terminals with any parts of the human body.
- (2). The modules should be kept in antistatic bags or other containers resistant to static for storage.
- (3). Only properly grounded soldering irons should be used.
- (4). If an electric screwdriver is used, it should be well grounded and shielded from commutator sparks.

(5) The normal static prevention measures should be observed for work clothes and working benches; for the latter conductive (rubber) mat is recommended.

(6). Since dry air is inductive to static, a relative humidity of 50-60% is recommended.

2.3 Soldering

- (1). Solder only to the I/O terminals.
- (2). Use only soldering irons with proper grounding and no leakage.
- (3). Soldering temperature : $280^{\circ}\text{C} \pm 10^{\circ}\text{C}$
- (4). Soldering time: 3 to 4 sec.
- (5). Use eutectic solder with resin flux fill.
- (6). If flux is used, the LCD surface should be covered to avoid flux spatters. Flux residue should be removed after wards.

2.4 Operation

- (1). The viewing angle can be adjusted by varying the LCD driving voltage V_0 .
- (2). Driving voltage should be kept within specified range; excess voltage shortens display life.
- (3). Response time increases with decrease in temperature.
- (4). Display may turn black or dark blue at temperatures above its operational range; this is (however not pressing on the viewing area) may cause the segments to appear "fractured".
- (5). Mechanical disturbance during operation (such as pressing on the viewing area) may cause the segments to appear "fractured".

2.5 Storage

If any fluid leaks out of a damaged glass cell, wash off any human part that comes into contact with soap and water. Never swallow the fluid. The toxicity is extremely low but caution should be exercised at all the time.

2.6 Limited Warranty

Unless otherwise agreed between DATA IMAGE and customer, DATA IMAGE will replace or repair any of its LCD and LCM which is found to be defective electrically and visually when inspected in accordance with DATA IMAGE acceptance standards, for a period on one year from date of shipment. Confirmation of such date shall be based on freight documents. The warranty liability of DATA IMAGE is limited to repair and/or replacement on the terms set forth above. DATA IMAGE will not responsible for any subsequent or consequential events.

Confidential Document
15. OUTLINE DRAWING

UNITS MM

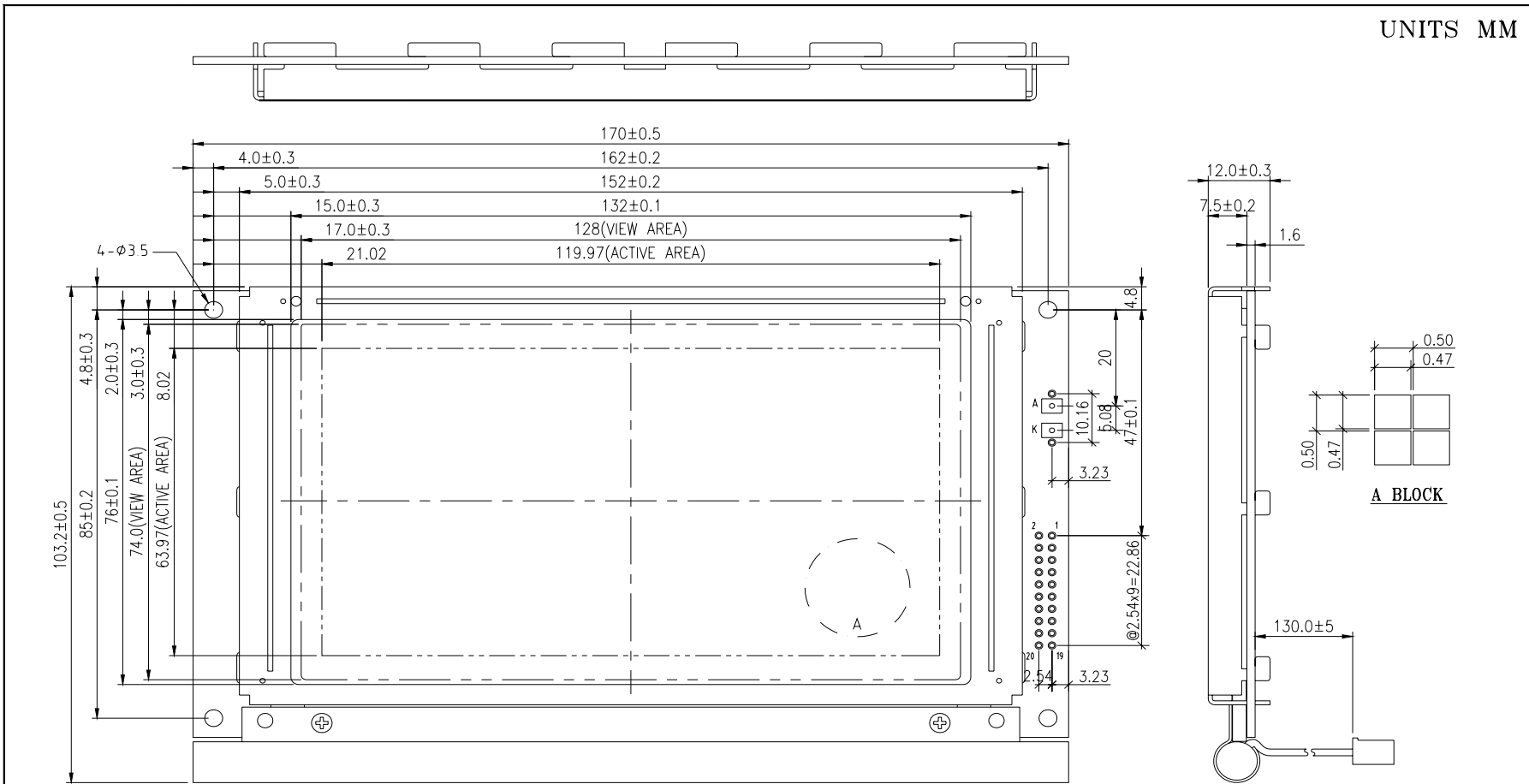

Note: tolerance is ± 0.3 unless otherwise noted.

				DATE:	11/15/00'	DATA IMAGE Corporation		
				DRAWN:		TITLE: LCM OUTLINE DIMENSION		
				CHECK:		A ₄	DWG. NO. Q971011	
				APPROVE:			PART. NO. GM24121A	REV. A
△	GM241200C_A = GM24121A_A	DATE	APPROVED			SCALE	1/1	SHEET 1 OF 1
AUTH	DESCRIPTION	DATE	APPROVED					
REVISIONS								

16. PACKAGE INFORMATION

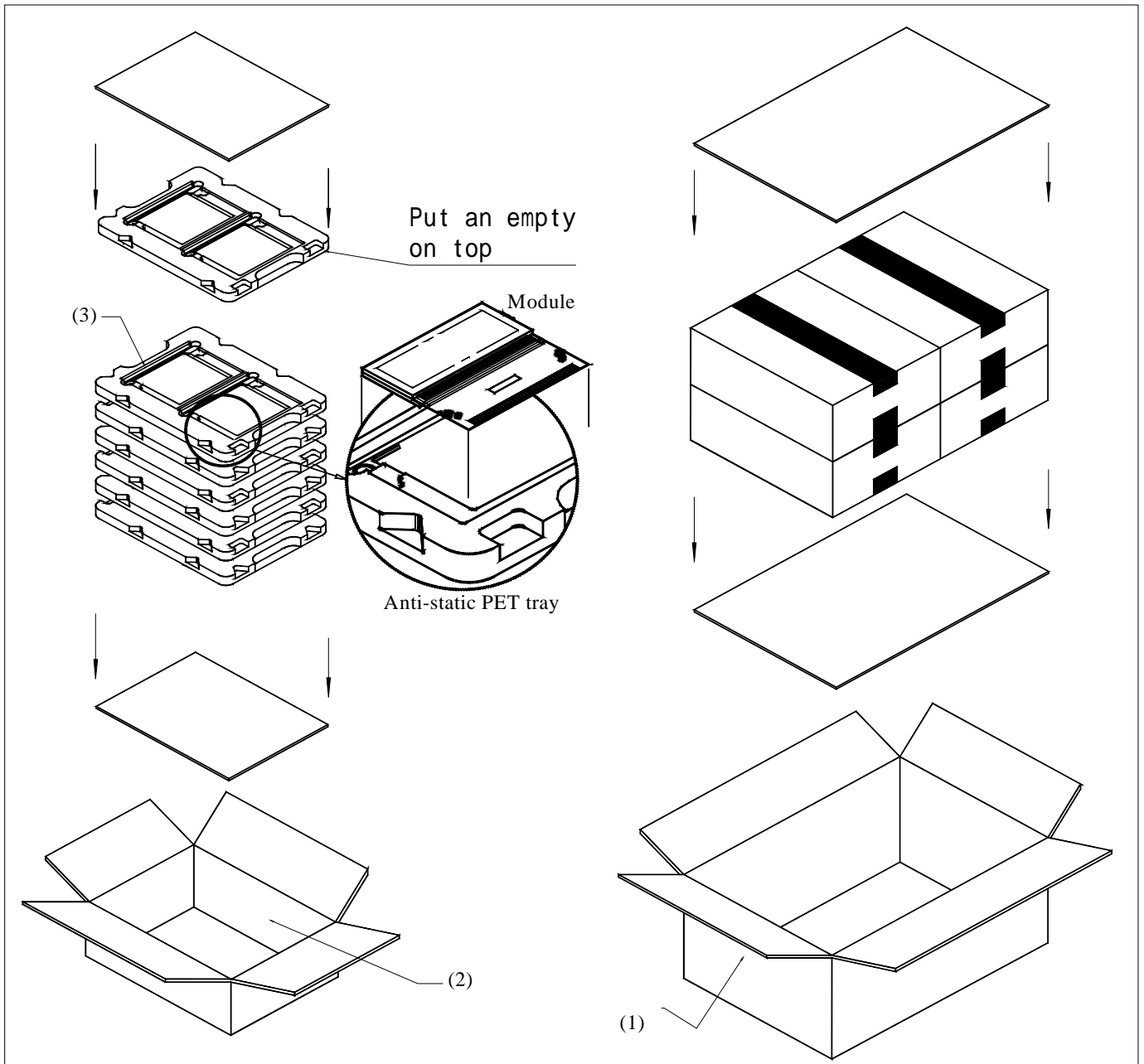

Item	Size(L*W*H)	Quantity	Note
1.Master Carton	482*282*279	1	
2.Inner Carton	267*224*115	4	
Quantity Per Inner Carton	12	Quantity per Master Carton	48
N . W	12.0 (kg)	G . W	13.0(kg)