

ROHS



# PRODUCT SPECIFICATION

## 128 X 64 DOTS LCD MODULE MODEL: G1206B5FTW6B-J1 Ver:1.1

<◇> Preliminary Specification

<◆> Finally Specification

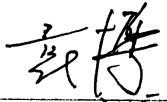
CUSTOMER'S APPROVAL	
CUSTOMER :	
SIGNATURE:	DATE:

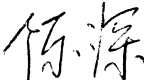
APPROVED BY	PM REVIEWED	PD REVIEWED	PREPARED BY
 2015.7.28			邱信隆



## Table of Contents

No.	Contents	Page
1.	FEATURES.....	4
2.	MECHANICAL SPECIFICATIONS.....	4
3.	ELECTRICAL SPECIFICATIONS.....	4
4.	TERMINAL FUNCTIONS AND BLOCK DIAGRAM.....	5
5.	TIMING CHARACTERISTICS.....	6
6.	INSTRUCTION SET.....	8
7.	QUALITY SPECIFICATIONS.....	10
8.	RELIABILITY.....	15
9.	HANDLING PRECAUTION.....	16
10.	OUTLINE DIMENSION.....	17
11.	PACKING INSTRUCTION.....	18

## 1. Features

The features of LCD are as follows

- \* Display mode : FSTN /Transmissive/Positive
- \* Drive IC : AIP31107&AIP31108
- \* Interface Input Data : 8 bit
- \* Driving Method : 1/64Duty, 1/6 Bias
- \* Viewing Direction : 6 O'clock
- \* Backlight : LED/Side White
- \*Sample NO. :

## 2. MECHANICAL SPECIFICATIONS

Item	Specification	Unit
Module Size	93(W) x 70 (H) x 13 (D)	mm
Number of Dots	128x64 Dots	
Viewing Area	70.2(H) x 38.8(V)	mm
Activity Area	66.52(H)x33.24(V)	mm
Dot Size	0.48(H) x 0.48(V)	mm
Dot Pitch	0.52(H) x0.52(V)	mm

## 3. ELECTRICAL SPECIFICATIONS

### 3-1 ABSOLUTR MAZIMUM RATINGS (Ta = 25 °C)

Item	Symbol	Standard Value			Unit
		Min.	Typ.	Max.	
Supply Voltage For Logic	$V_{DD} - V_{SS}$	0.3	-	7.0	V
Supply voltage	$V_{EE}$	$V_{DD}-19$		$V_{DD}+0.3$	V
Supply Voltage For LCD Drive	$V_{LCD}$	$V_{EE}-0.3$	-	$V_{DD} +0.3$	V
Input Voltage	$V_{in}$	-	-	-	V
Operating Temp.	Top	-20	-	+70	°C
Storage Temp.	Tst	-30	-	+80	°C

\*. NOTE: The response time will be extremely slow when the operating temperature is around -10°C, and the back ground will become darker at high temperature operating.

### 3-2 ELECTRICAL CHARACTERISTICS

Item	Symbol	Test Condition	Min.	Typ.	Max.	Unit
Logic supply Voltage	$V_{DD} - V_{SS}$	$T_a = 25\text{ }^\circ\text{C}$ $V_{DD}=5V \pm 10\%$	4.5	5.0	5.5	V
LCD Drive	$V_{LCD}$		7.7	8.0	8.3	V
Input Voltage	$V_{IH}$		$0.7V_{DD}$	-	$V_{DD}$	V
	$V_{IL}$		0	-	$0.3V_{DD}$	V
Output voltage	$V_{OH}$		2.4	-	-	V
	$V_{OL}$		-	-	0.4	V
Frame Frequency	$f_{FLM}$		-	78	-	Hz
Current Consumption	$I_{DD}$		-	20.7	-	mA

### 3-3. BACKLIGHT

#### 3-3-1. Absolute Maximum Ratings

Item	Symbol	Condition	Min.	Typ.	Max.	Unit
Forward Voltage	VF	$T_a = 25\text{ }^\circ\text{C}$	2.9	-	3.3	V
Reverse Dissipation	PD		-	-	264	mW
Reverse Current	IR		-	-	15	$\mu\text{A}$

#### 3-3-2. Electrical-optical Characteristics

Item	Symbol	Condition	Min.		Typ.		Max.		Unit
Forward Voltage	VF	$I_f=80\text{mA}$ $T_a = 25\text{ }^\circ\text{C}$	2.9		3.1		3.3		V
Luminance	$L_v$		200		-		-		$\text{cd/m}^2$
Colour Coordinate	-		X	Y	X	Y	X	Y	
			0.24	0.24	0.26	0.26	0.30	0.30	
Lifetime		$T_a=25\text{ }^\circ\text{C}$ $V_F=3.1\text{V}$ $I_F=80\text{mA (TYP)}$	20000		-		-		Hours

The brightness is measured without LCD panel;

Backlight lifetime means luminance value larger than half of the original after 20000 hours' continuous working.

## 4. TERMINAL FUNCTIONS AND BLOCK DIAGRAM

### 4-1. INTERFACE PIN FUNCTION DESCRIPTION

PIN NO.	SYMBOL	FUNCIONS
1	VSS	Ground (0V)
2	VDD	Supply voltage for logical circuit(5V)
3	V0	Supply voltage for LCD driving
4	RS	Select register signal
5	R/W	H: Data Read (LCM to MPU) ; L: Data Write (MPU to LCM)
6	E	Enable Signal
7~14	DB0~DB7	Data bus line
15	/CS1	Chip Selection Signal for U2
16	/CS2	Chip Selection Signal for U3
17	/RST	Reset (Active "LOW")
18	VEE	Negative voltage supply pin
19	LED_A	Backlight (+5V)
20	LED_K	Backlight (-)

### 4-2. BLOCK DIAGRAM

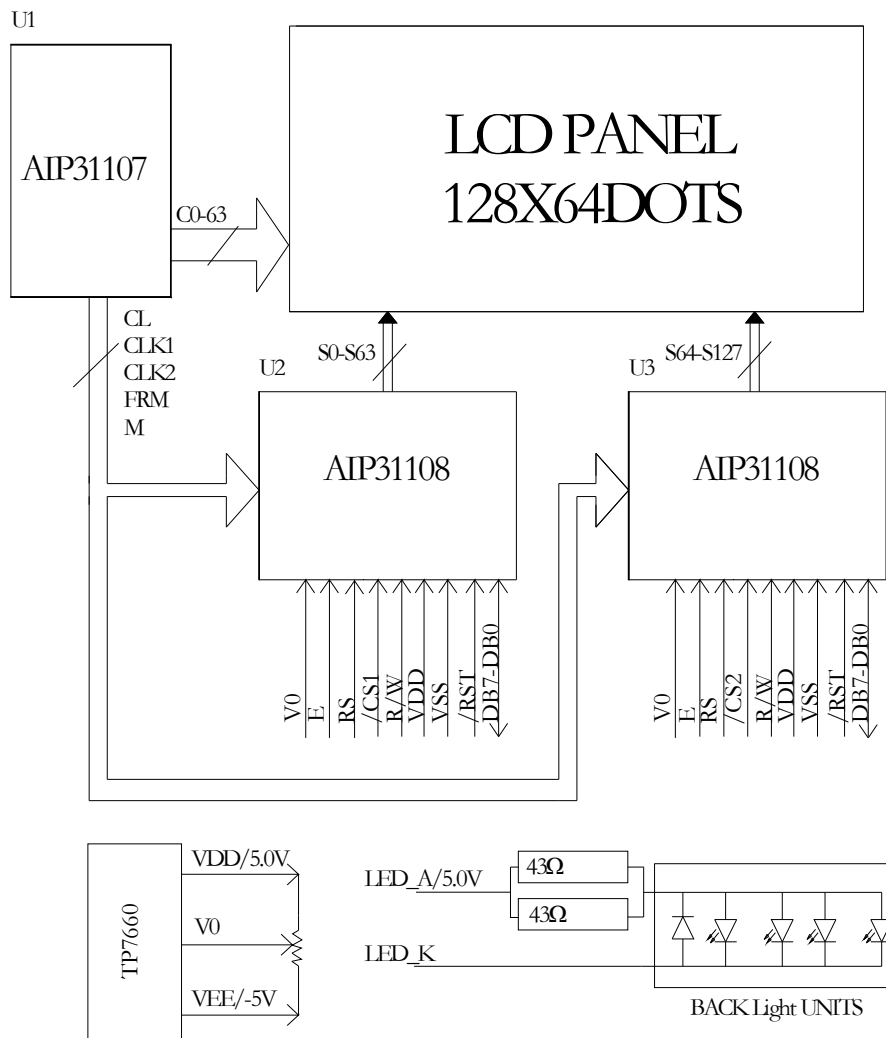

## 5. TIMING CHARACTERISTICS

Characteristic	Symbol	Min	Typ	Max	Unit
E Cycle	$t_c$	1000	—	—	ns
E High Level Width	$t_{WH}$	450	—	—	ns
E Low Level Width	$t_{WL}$	450	—	—	ns
E Rise Time	$t_R$	—	—	25	ns
E Fall Time	$t_F$	—	—	25	ns
Address Set-Up Time	$t_{ASU}$	140	—	—	ns
Address Hold Time	$t_{AH}$	10	—	—	ns
Data Set-Up Time	$t_{DSU}$	200	—	—	ns
Data Delay Time	$t_D$	—	—	320	ns
Data Hold Time (Write)	$t_{DHW}$	10	—	—	ns
Data Hold Time (Read)	$t_{DHR}$	20	—	—	ns

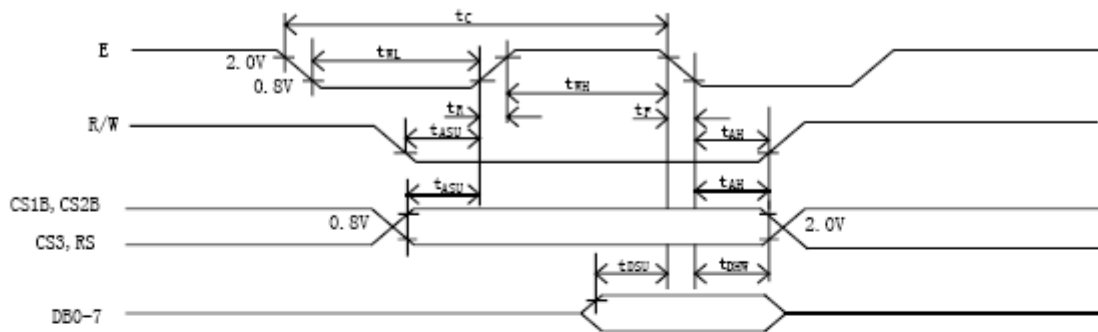

Fig 3. MPU write timing

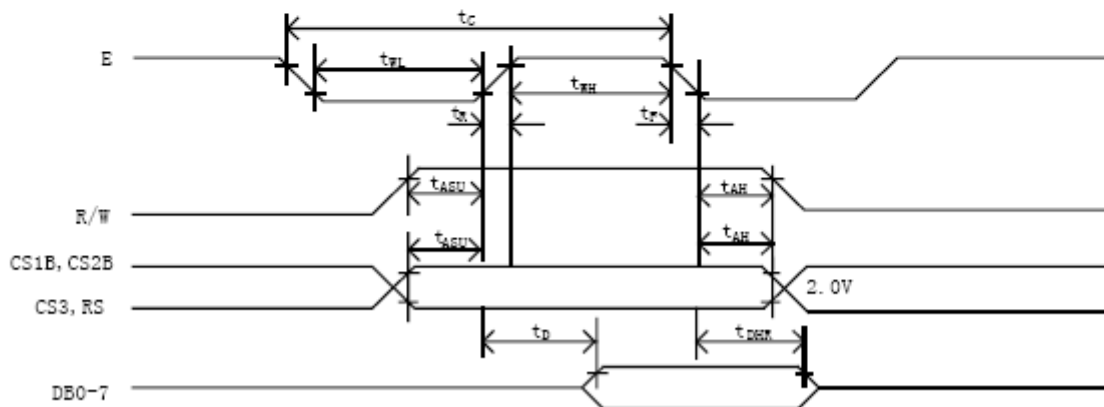

Fig 4. MPU Read timing

## 6. INSTRUCTION SET

The display control instructions control the internal state of the AIP31108. Instruction is received from MPU to AIP31108 for the display control. The following table shows various instructions.

Instruction	RS	R/W	DB7	DB6	DB5	DB4	DB3	DB2	DB1	DB0	Function	
Display ON/OFF	L	L	L	L	H	H	H	H	H	L/H	Controls the display on or off. Internal status and display RAM data is not affected. L:OFF, H:ON	
Set Address (Y address)	L	L	L	H	Y address (0~63)						Sets the Y address in the Y address counter.	
Set Page (X address)	L	L	H	L	H	H	H	Page (0-7)			Sets the X address at the X address register.	
Display Start Line (Z address)	L	L	H	H	Display start line (0-63)						Indicates the display data RAM displayed at the top of the screen.	
Status Read	L	H	busy	L	On/off	reset	L	L	L	L	Read status. BUSY L: Ready H: In operation ON/OFF L: Display ON H: Display OFF RESET L: Normal H: Reset	
Write Display Data	H	L	Write Data									Writes data (DB0:7) into display data RAM. After writing instruction, Y address is increased by 1 automatically.
Read Display Data	H	H	Read Data									Reads data (DB0:7) from display data RAM to the data bus.

### 1. Display On/Off

RS	R/W	DB7	DB6	DB5	DB4	DB3	DB2	DB1	DB0
0	0	0	0	1	1	1	1	1	D

The display data appears when D is 1 and disappears when D is 0. Though the data is not on the screen with D=0, it remains in the display data RAM. Therefore, you can make it appear by changing D=0 into D=1.

### 2. Set Address (Y Address)

RS	R/W	DB7	DB6	DB5	DB4	DB3	DB2	DB1	DB0
0	0	0	1	AC5	AC4	AC3	AC2	AC1	AC0

Y address (AC0 ~ AC5) of the display data RAM is set in the Y address counter. An address is set by instruction and increased by 1 automatically by read or write operations of display data.

### 3. Set Page (X Address)

RS	R/W	DB7	DB6	DB5	DB4	DB3	DB2	DB1	DB0
0	0	1	0	1	1	1	AC2	AC1	AC0

X address(AC0 ~ AC2) of the display data RAM is set in the X address register. Writing or reading to or from MPU is executed in this specified page until the next page is set.



#### 4. Display Start Line (Z Address)

RS	R/W	DB7	DB6	DB5	DB4	DB3	DB2	DB1	DB0
0	0	1	1	AC5	AC4	AC3	AC2	AC1	AC0

Z address (AC0 ~ AC5) of the display data RAM is set in the display start line register and displayed at the top of the screen. When the display duty cycle is 1/64 or others(1/32 ~ 1/64), the data of total line number of LCD screen, from the line specified by display start line instruction, is displayed.

#### 5. Status Read

RS	R/W	DB7	DB6	DB5	DB4	DB3	DB2	DB1	DB0
0	1	BUSY	0	ON/OFF	RESET	0	0	0	0

- BUSY  
 When BUSY is 1, the Chip is executing internal operation and no instructions are accepted.  
 When BUSY is 0, the Chip is ready to accept any instructions.
- ON/OFF  
 When ON/OFF is 1, the display is on.  
 When ON/OFF is 0, the display is off.
- RESET  
 When RESET is 1, the system is being initialized. In this condition, no instructions except status read can be accepted.  
 When RESET is 0, initializing has finished and the system is in the usual operation condition.

#### 6. Write Display Data

RS	R/W	DB7	DB6	DB5	DB4	DB3	DB2	DB1	DB0
1	0	D7	D6	D5	D4	D3	D2	D1	D0

Writes data (D0 ~ D7) into the display data RAM.  
 After writing instruction, Y address is increased by 1 automatically.

#### 7. Read Display Data

RS	R/W	DB7	DB6	DB5	DB4	DB3	DB2	DB1	DB0
1	1	D7	D6	D5	D4	D3	D2	D1	D0

Reads data (D0 ~ D7) from the display data RAM.  
 After reading instruction, Y address is increased by 1 automatically.

## 7. QUALITY SPECIFICATIONS

### 7-1. LCM Appearance and Electric inspection Condition

1. Inspection will be done by placing LCM 30cm away from inspector's eyeballs under normal illumination.

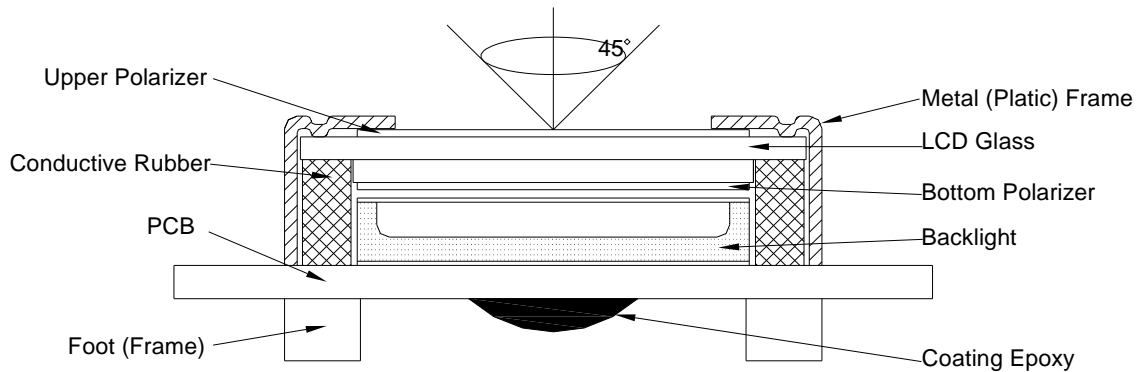

2. View Angle: with in 45° around perpendicular line.

### 7-2. Definition

#### 1. COB

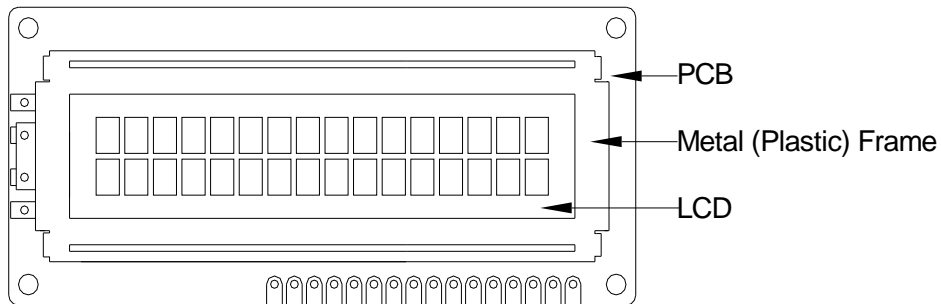

#### 2. Heat Seal

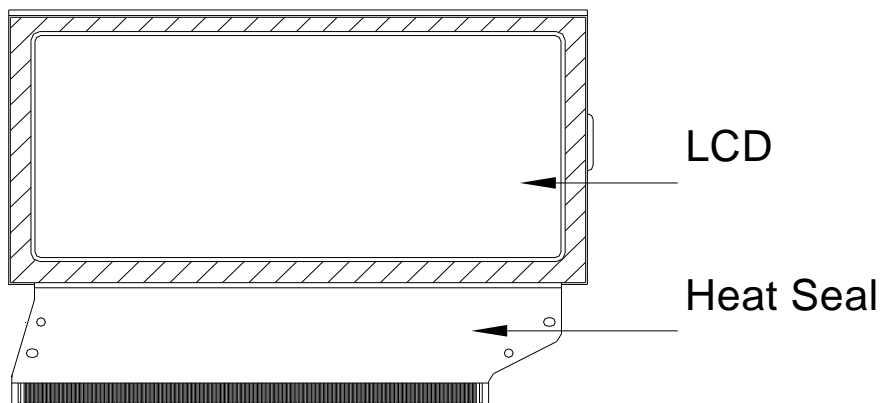

#### 3. TAB and COG

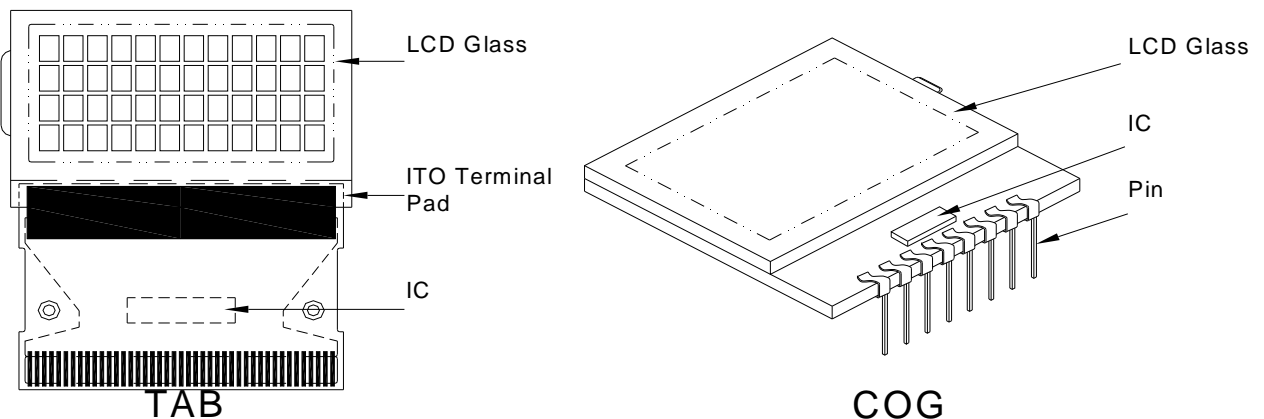

### 7-3. Sampling Plan and Acceptance

#### 1. Sampling Plan

MIL - STD - 105E ( || ) ordinary single inspection is used.

#### 2. Acceptance

Major defect: AQL = 0.65%

Minor defect: AQL = 1.5%

### 7-4. Criteria

#### 1. COB

Defect	Inspection Item	Inspection Standards	
Major	PCB copper flakes peeling off	Any copper flake in viewing Area should be greater than 1.0mm <sup>2</sup>	Reject
Major	Height of coating epoxy	Exceed the dimension of drawing	Reject
Major	Void or hole of coating epoxy	Expose bonding wire or IC	Reject
Major	PCB cutting defect	Exceed the dimension of drawing	Reject

#### 2. SMT

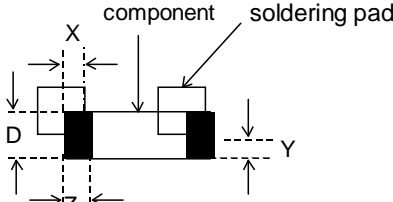
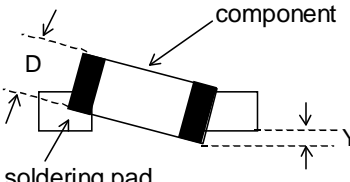
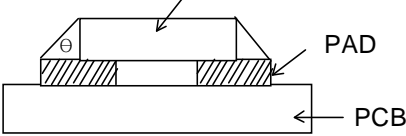
Defect	Inspection Item	Inspection Standards	
Minor	Component marking not readable		Reject
Minor	Component height	Exceed the dimension Of drawing	Reject
Major	Component solder defect (missing , extra, wrong component or wrong orientation)		Reject
Minor	Component position shift 	$X < 3/4Z$ $Y > 1/3D$	Reject Reject
Minor	Component tilt 	$Y > 1/3D$	Reject
Minor	Insufficient solder 	$\theta \leq 20^\circ$	Reject

### 3. Metal (Plastic) Frame

Defect	Inspection Item	Inspection Standards	
Major	Crack / breakage	Anywhere	
Minor	Frame Scratch	W	L
		$w < 0.1\text{mm}$	Any
		$0.1 \leq w < 0.2\text{mm}$	$L \leq 5.0\text{mm}$
		$0.2 \leq w < 0.3\text{mm}$	$L \leq 3.0\text{mm}$
		$w \geq 0.3\text{mm}$	Any
		Note : 1. Above criteria applicable to scratch lines with distance greater than 5mm. 2. Scratch on the back side of frame (not visible) can be ignored .	
Minor	Frame Dent , Prick $\Phi = \frac{L + W}{2}$		Acceptable of Dents / Pricks
		$\Phi \leq 1.0\text{mm}$	2
		$1.0 < \Phi \leq 1.5\text{mm}$	1
		$1.5\text{mm} < \Phi$	0
Note : 1. Above criteria applicable to any two dents / pricks with distance greater than 5mm 2. Dent / prick on the back side of frame (not visible) can be ignored			
Minor	Frame Deformation	Exceed the dimension of drawing	
Minor	Metal Frame Oxidation	Any rust	

### 4. Flexible Film Connector (FFC)

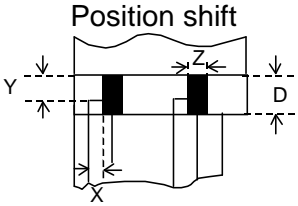
Defect	Inspection Item	Inspection Standards	
Minor	Tilted soldering	Within the angle $+5^\circ$	Acceptable
Minor	Uneven solder joint /bump		Reject
Minor	Hole $\Phi = \frac{L + W}{2}$	Expose the conductive line	Reject
		$\Phi > 1.0\text{mm}$	Reject
Minor	 <p>Position shift</p>	$Y > 1/3D$	Reject
		$X > 1/2Z$	Reject

### 5. Screw

Defect	Inspection Item	Inspection Standards	
Major	Screw missing/loosen		Reject
Minor	Screw oxidation	Any rust	Reject
Minor	Screw deformation	Difficult to accept screw driver	Reject

### 6. Heatseal 、TCP 、FPC

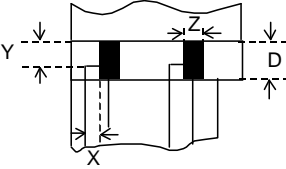
Defect	Inspection Item	Inspection Standards	
Major	Scratch expose conductive layer		Reject
Minor	HS Hole $\Phi = \frac{L+W}{2}$	$\Phi > 0.5\text{mm}$	Reject
Major	Adhesion strength	Less than the specification	Reject
Minor	Position shift 	$Y > 1/3D$	Reject
		$X > 1/2Z$	Reject
Major	Conductive line break		Reject

### 7. LED Backing Protective Film and Others

Defect	Inspection Item	Inspection Standards	
Minor	LED dirty, prick	Acceptable number of units	
		$\Phi \leq 0.10\text{mm}$	Ignore
		$0.10 < \Phi \leq 0.15\text{mm}$	2
		$0.15 < \Phi \leq 0.2\text{mm}$	1
		$\Phi > 0.2\text{mm}$	0
		The distance between any two spots should be $\geq 5\text{mm}$ Any spot/dot/void outside of viewing area is acceptable	
Minor	Protective film tilt	Not fully cover LCD	Reject
Major	COG coating	Not fully cover ITO circuit	Reject

### 8. Electric Inspection

Defect	Inspection Item	Inspection Standards	
Major	Short		Reject
Major	Open		Reject

9. Inspection Specification of LCD

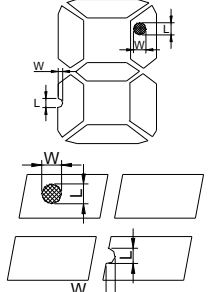
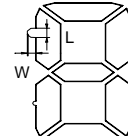
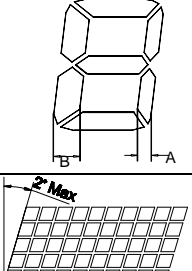
Defect	Inspect Item		Inspection Standards				
Minor	Linear Defect	* Glass Scratch * Polarizer Scratch * Fiber and Linear material	W	$W \leq 0.03$	$0.03 < W \leq 0.05$	$W > 0.05$	
			L	$L < 5$	$L < 3$	Any	
			ACC. NO.	1	1	Reject	
			Note	L is the length and W is the width of the defect			
Minor	Black Spot and Polarizer Pricked	* Foreign material between glass and polarizer or glass and glass * Polarizer hole or protuberance by external force	$\Phi$	$\Phi \leq 0.1$	$0.1 < \Phi \leq 0.15$	$0.15 < \Phi \leq 0.2$	$\Phi > 0.2$
			ACC. NO.	3EA / 100mm <sup>2</sup>	2	1	0
			Note	$\Phi$ is the average diameter of the defect. Distance between two defects > 10mm.			
Minor	White Spot and Bubble in polarizer	* Unobvious transparent foreign material between glass and glass or glass and polarizer * Air protuberance between polarizer and glass	$\Phi$	$\Phi \leq 0.3$	$0.3 < \Phi \leq 0.5$	$0.5 < \Phi$	
			ACC. NO.	3EA / 100mm <sup>2</sup>	1	0	
			Note	$\Phi$ is the average diameter of the defect. Distance between two defects > 10mm.			
Minor	Segment Defect		$\Phi$	$\Phi \leq 0.10$	$0.10 < \Phi \leq 0.20$	$0.20 < \Phi \leq 0.25$	$\Phi > 0.25$
			ACC. NO.	3EA / 100mm <sup>2</sup>	2	1	0
			Note	W is more than 1/2 segment width			Reject
				$\Phi = \frac{L + W}{2}$ Distance between two defect is 10mm			
Minor	Protuberant Segment	 $\Phi = (L + W) / 2$	$\Phi$	$\Phi \leq 0.10$	$0.10 < \Phi \leq 0.20$	$0.20 < \Phi \leq 0.25$	$\Phi > 0.25$
			W	Glue	$W \leq 1/2$ Seg $W \leq 0.2$	$W \leq 1/2$ Seg $W \leq 0.2$	Ignore
			ACC. NO.	3EA / 100mm <sup>2</sup>	2	1	0
Minor	Assembly Mis-alignment		1. Segment				
			B	$B \leq 0.4\text{mm}$	$0.4 < B \leq 1.0\text{mm}$	$B > 1.0\text{mm}$	
			B-A	$B-A < 1/2B$	$B-A < 0.2$	$B-A < 0.25$	
			Judge	Acceptable	Acceptable	Acceptable	
			2. Dot Matrix				
	Deformation > 2°			Reject			
Minor	Stain on LCD Panel Surface		Accept when stains can be wiped lightly with a soft cloth or a similar one. Otherwise, judged according to the above items: "Black spot" and "White Spot"				

### 8. RELIABILITY

No	Item	Condition	Quantity	Criteria
1	High Temperature Operating	70°C, 96Hrs	2	GB/T2423.2-2008
2	Low Temperature Operating	-20°C, 96Hrs	2	GB/T2423.1-2008
3	High Humidity	50°C, 90%RH, 96Hrs	2	GB/T2423.3-2006
4	High Temperature Storage	80°C, 96Hrs	2	GB/T2423.2-2008
5	Low Temperature Storage	-30°C, 96Hrs	2	GB/T2423.1-2008
6	Thermal Cycling Test	-20°C, 60min~70°C, 60min, 20 cycles.	2	GB/T2423.2-2012
7	Packing vibration	Frequency range:10Hz~50Hz Acceleration of gravity:5G X,Y,Z 30 min for each direction.	2	GB/T5170.1-2009
8	Electrical Static Discharge	Air: ±8KV 150pF/330 Ω 5 times	2	GB/T17626.2-2006
		Contact: ± 4KV 150pF/330 Ω 5 times		
9	Drop Test (Packaged)	Height:80 cm,1 corner, 3 edges, 6 surfaces.	2	GB/T2423.8-1995

Note: 1) Above conditions are suitable for our company standard products.  
 2) For restrict products, the test conditions listed as above must be revised.

## 9. HANDLING PRECAUTION

### (1) Mounting Method

The panel of the LCD Module consists of two thin glass plates with polarizers which easily get damaged since the Module is fixed by utilizing fitting holes in the printed circuit board. Extreme care should be taken when handling the LCD Modules.

### (2) Caution of LCD handling & cleaning

When cleaning the display surface, use soft cloth with solvent (recommended below) and wipe lightly.

- Isopropyl alcohol
- Ethyl alcohol
- Trichloro trifloro thane

Do not wipe the display surface with dry or hard materials that will damage the polarizer surface.

Do not use the following solvent:

- Water- Ketone- Aromatics

### (3) Caution against static charge

The LCD Module use C-MOS LSI drivers, so we recommend that you connect any unused input terminal to VDD or VSS, do not input any signals before power is turned on. And ground your body, Work/assembly table. And assembly equipment to protect against static electricity.

### (4) Packaging

- Modules use LCD elements, and must be treated as such. Avoid intense shock and falls from a height.
- To prevent modules from degradation. Do not operate or store them exposed directly to sunshine or high temperature/humidity.

### (5) Caution for operation

- It is indispensable to drive LCD's within the specified voltage limit since the higher voltage than the limit shorten LCD life. An electrochemical reaction due to direct current causes LCD deterioration, Avoid the use of direct current drive.
- Response time will be extremely delayed at lower temperature than the operating temperature range and on the other hand at higher temperature LCD's show dark color in them. However those phenomena do not mean malfunction or out of order with LCD's. Which will come back in the specified operating temperature range.
- If the display area is pushed hard during operation, some font will be abnormally displayed but it resumes normal condition after turning off once.
- A slight dew depositing on terminals is a cause for electro-chemical reaction resulting in terminal open circuit.

Usage under the relative condition of 40°C, 50%RH or less is reequired.

### (6) Storage

In the case of storing for a long period of time (for instance.) For years) for the purpose or replacement use, The following ways are recommended.

- Storage in a polyethylene bag with sealed so as not to enter fresh air outside in it, And with no desiccant.
- Placing in a dark place where neither exposure to direct sunlight nor light is. Keeping temperature in the specified storage temperature range.
- Storing with no touch on polarizer surface by the anything else. (It is recommended to store them as they have been contained in the inner container at the time of delivery)

### (7) Safety

- It is recommendable to crash damaged or unnecessary LCD into pieces and wash off liquid crystal by using solvents such as acetone and ethanol. Which should be burned up later.

- When any liquid crystal leaked out of a damaged glass cell comes in contac with your hands, please wash it off well with soap and wate

### (8) Other

- After the product shipped, any product quality issues must be feedback within three months, otherwise, we will not be responsible for the subsequent or consequential events.



# 10. OUTLINE DIMENSION

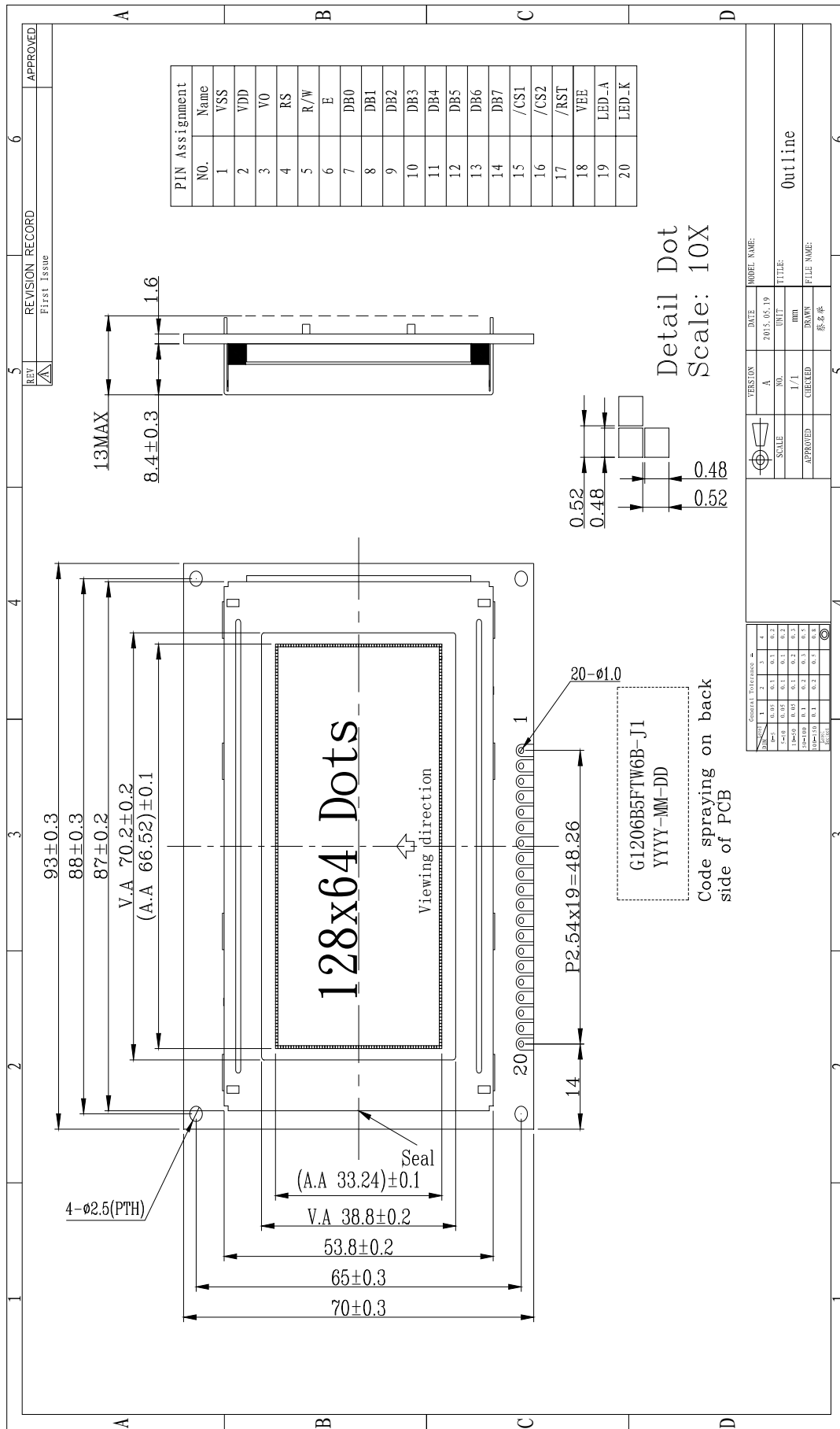

# 11. PACKING INSTRUCTION

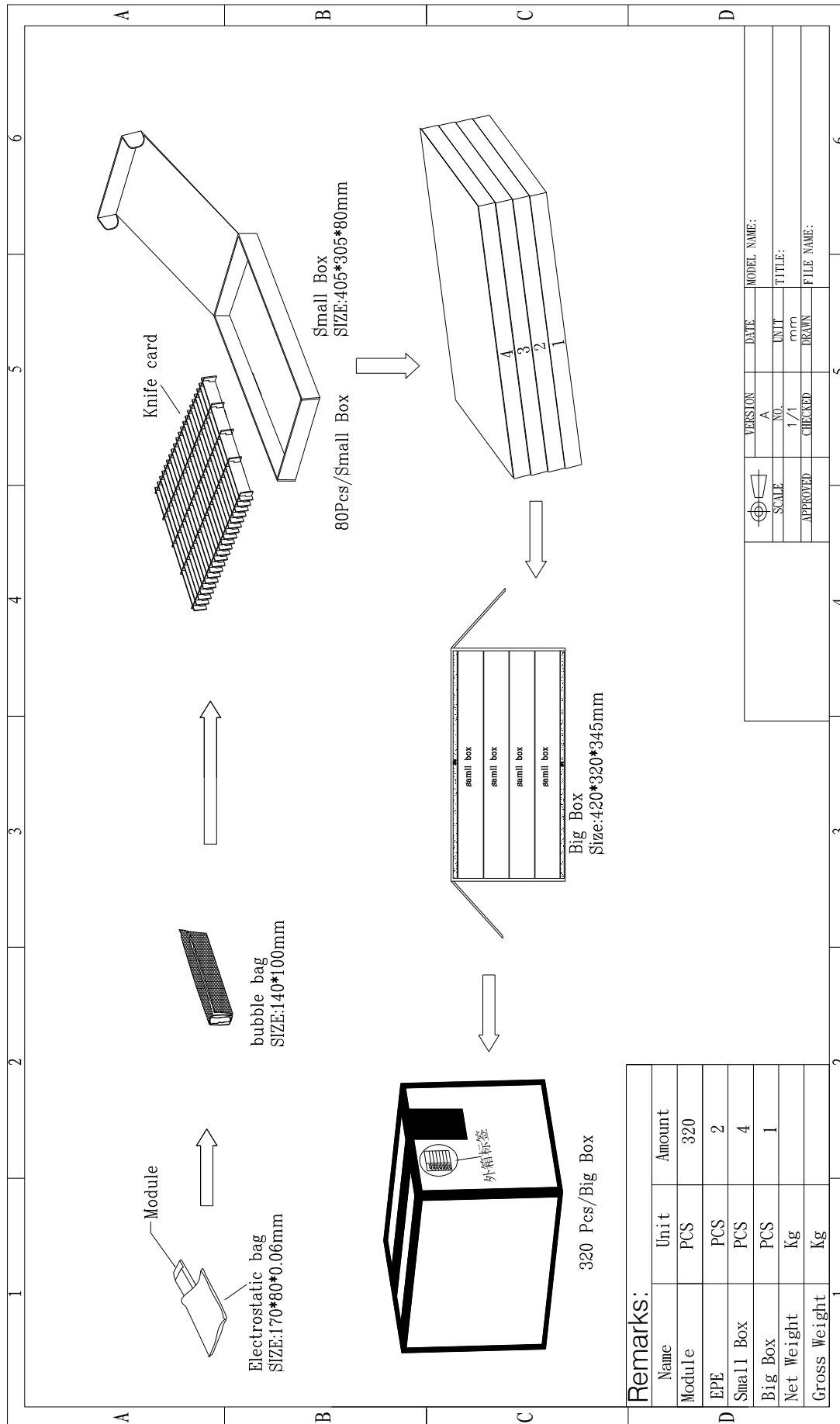

**Remarks:**

Name	Unit	Amount
Module	PCS	320
EPE	PCS	2
Small Box	PCS	4
Big Box	PCS	1
Net Weight	Kg	
Gross Weight	Kg	

SCALE	VERSION	DATE	MODEL NAME:
APPROVED	A		
CHECKED	NO.	UNIT	TITLE:
DRAWN	1/1	mm	
			FILE NAME: