



FutureTM
未来科技

飞优特科技（深圳）有限公司

FUTURE S&T(SHEN ZHEN)CO.,LTD

Approval Sheet

Customer : MC Part No. : FG12864CT-YKBY

Sample Approved: _____ Sample Quantity: _____

Sample Date: _____

1:Outlook

Items	Description	Result	
Outer Dimension	Length、 Width、 Height、 Positioning Hole、 I/O Position	<input type="checkbox"/> OK	<input type="checkbox"/> NG
LCD Color	LCD Background Color	<input type="checkbox"/> OK	<input type="checkbox"/> NG
LED Color	LED Lighting Color	<input type="checkbox"/> OK	<input type="checkbox"/> NG
Others	Customer Additional Request	<input type="checkbox"/> OK	<input type="checkbox"/> NG
Outlook Description :			

2:Electrical Characteristics

Items	Description	Result	
LCD Voltage	LCD Driving Voltage: V _{LCD} =9.5V	<input type="checkbox"/> OK	<input type="checkbox"/> NG
Viewing Angle	LCD Operating Viewing Angle	<input type="checkbox"/> OK	<input type="checkbox"/> NG
LCM Current Consumption	LCM current consumption satisfy customer request	<input type="checkbox"/> OK	<input type="checkbox"/> NG
LED Current Consumption	LED lighting Current Consumption satisfy customer request	<input type="checkbox"/> OK	<input type="checkbox"/> NG
Electrical Characteristics Description :			

Conclusion: Can go to M/P according to samples
 Need to be revised according to above description

Approved By:		Verified By:	
---------------------	--	---------------------	--

CONTENTS

1 FUNCTION & FEATURES	1
2 BLOCK DIAGRAM.....	1
3 DIMENSIONAL CD DRAWING	2
4 POWER SUPPL	3
5 PIN DESCRIPTION	3
6 MAXIMUM ABSOLUTE LIMIT (T=25°C).....	4
7 ELECTRICAL CHARACTERISTICS	4
7.1 DC Characteristics(T=25°C, VSS=0V).....	4
Note: VSS=0V。	4
7.2 Backlight Specifications (Ta=25°C).....	4
7.3 AC Characteristics	5
8 Instruction Description	6
9 QUALITY SPECIFICATIONS.....	7
9.1 Defect classification.....	7
9.2 Note on defect classification.....	8
9.3. Reliability of LCM.....	14
10 DESCRIBE TO THE PART NO:.....	14
11 GUARTANTEE	14

1 FUNCTION & FEATURES

ITEM	Normal dimensions
Display Format	128*64 Dots
Module dimension	76.1(W)*53.8 (H)*9.5(T) mm
Viewing area	70.7(W)*38.8 (H) mm
Duty/bias	1/65Duty,1/9Bias
LCD mode	STN(Y-G)/Positive/Transmissive
Viewing direction	6:00 O'clock

2 BLOCK DIAGRAM

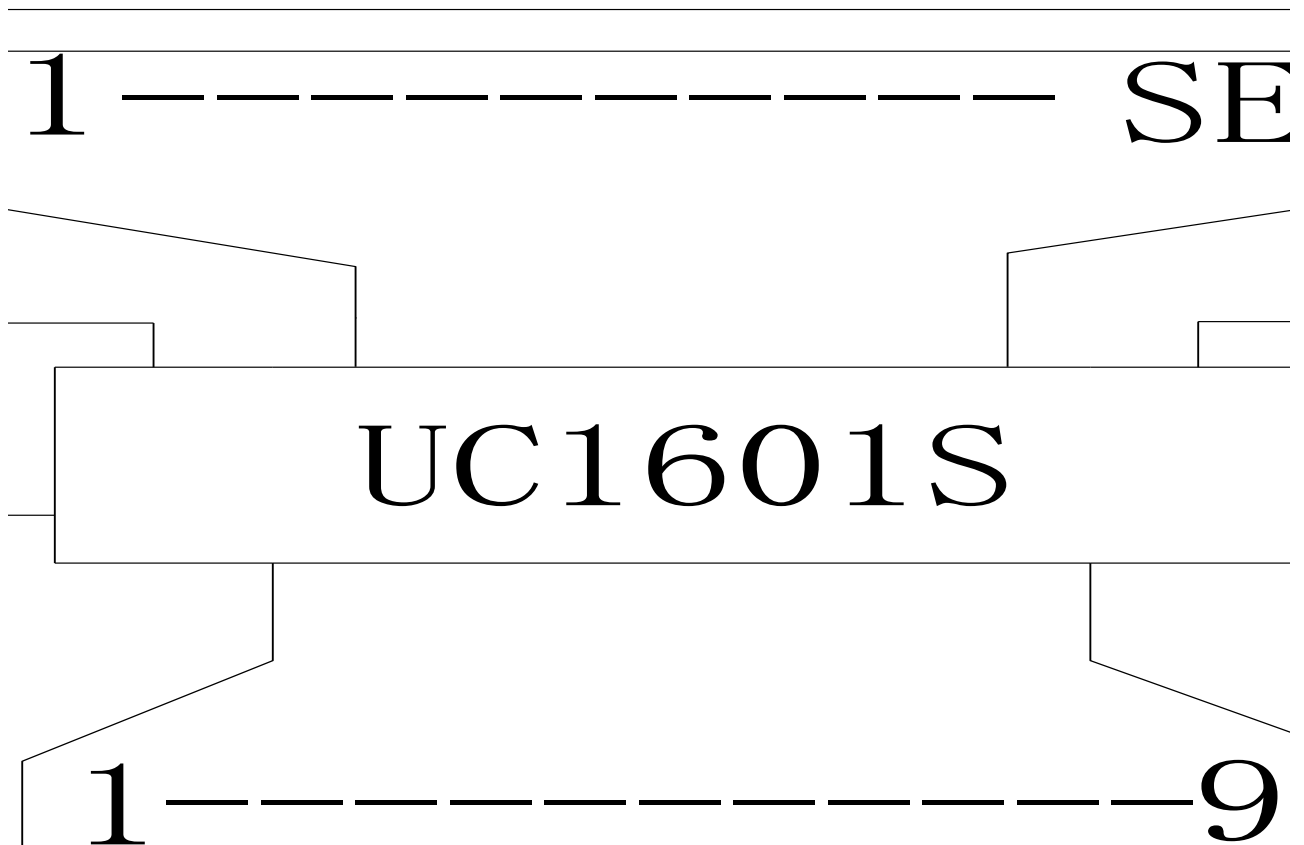

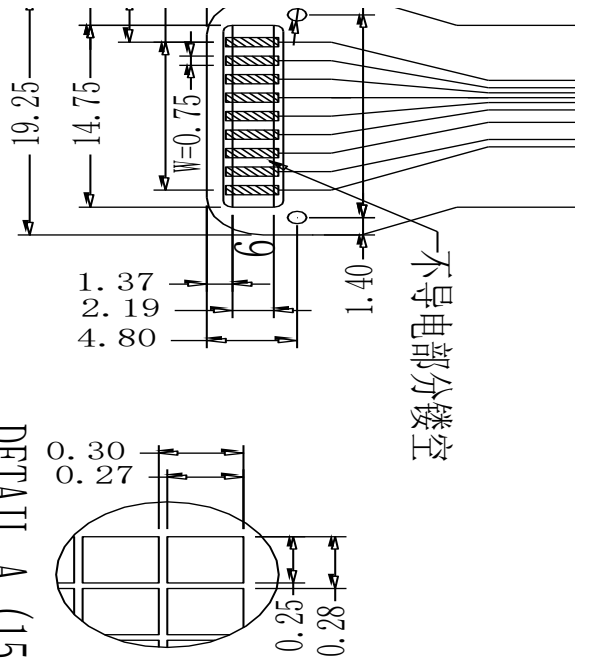

3 DIMENSIONAL CD DRAWING



DETAIL A (15:1)

20mm

- FSTN/Positive/Reflective
- 1/48Duty, 1/7Bias; VDD=3.3V, VLCD=9.0V
- 6:00 O'clock
- 10~+60 ° C
- 20~+70 ° C
- COG/FPC
- UC1601S
- Without

	 <p>飞优特科技(深圳)有限公司 FUTURE S&T (SHEN ZHEN) CO., LTD TEL: +86-755-29675886, FAX: +86-755-29675495 E-mail: sales@futurelcd.com</p>	 <p>CD</p>	<p>UNIT: MM SIZE: A4</p> <p>SHEET: 1 OF 1</p>	
LCM NO.: FG1284804-FCNN	DWG NO.: FG1284804-FCNN-CD	REV: A1		
DRAWN BY :	ECC BY :	APPROVED BY :		

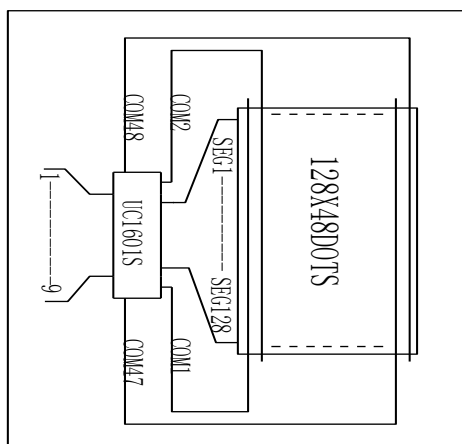

4 POWER SUPPL

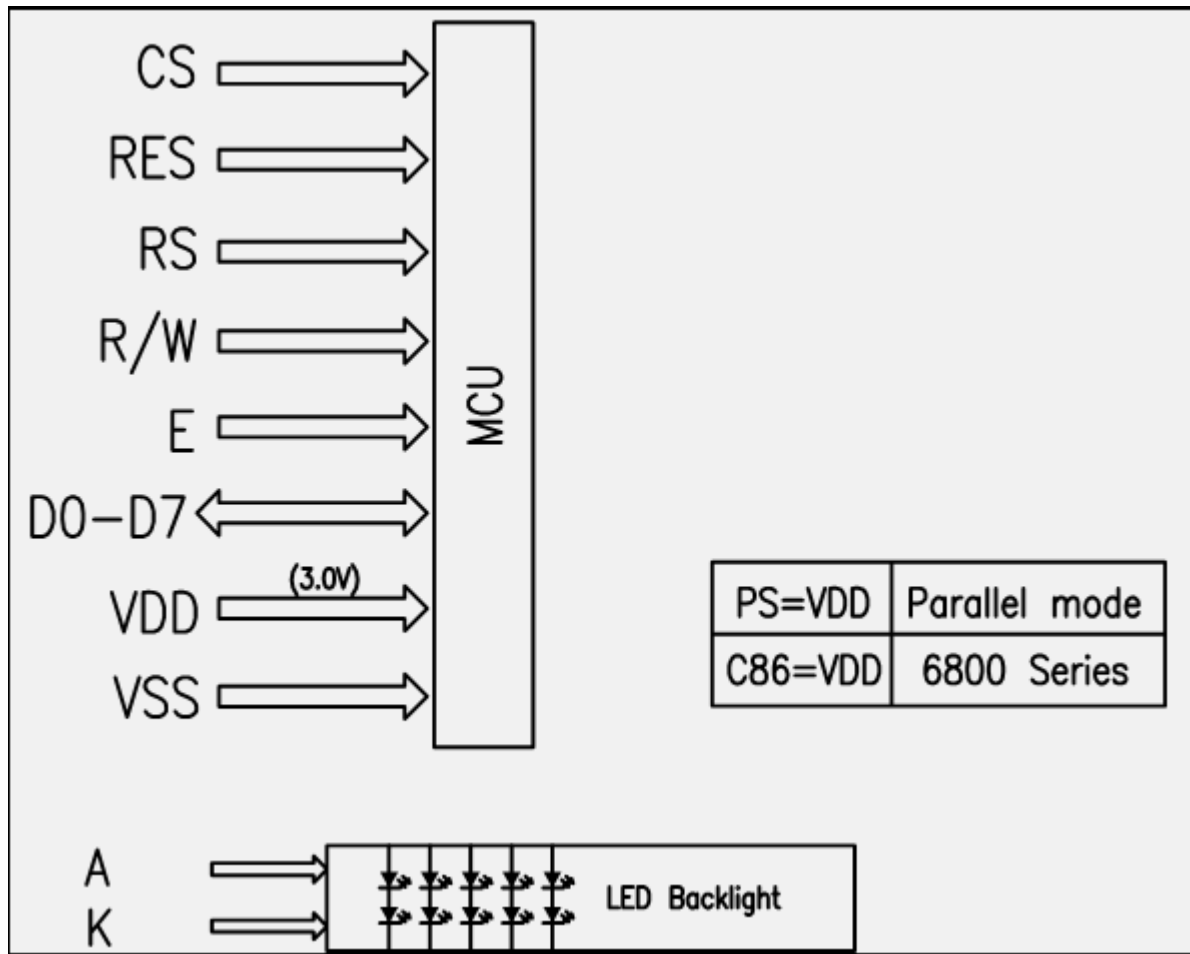

5 PIN DESCRIPTION

Pin no.	Symbol	Function
1	VSS	Power Ground
2	VDD	Power Supply
3	V0	LCD driving voltage
4	RES	Reset pin
5	CS	Chip select
6	RS	Determines whether the data bits are data or a command
7	R/W	Read/write control signal input terminal
8	E	Enable clock input
9-16	DB0-DB7	data bus
17	A	Power Supply for LED B/L (+)
18	K	Power Supply for LED B/L (-)

6 MAXIMUM ABSOLUTE LIMIT (T=25°C)

Item	Symbol	Standard value	Unit
supply voltage	V _{DD}	-0.3~3.6	V
LCD driving voltage	V _{LCD}	-0.3~13.5	V
Operating temperature	Topr	-20~+70	°C
Storage temperature	Tstg	-40~+70	°C

7 ELECTRICAL CHARACTERISTICS

7.1 DC Characteristics(T=25°C, VSS=0V)

Item	Symbol	Min	Type	Max	Unit	Test condition
Operating voltage	V _{DD}	2.8	3.0	3.2	V	-
Input voltage	V _{IL}	V _{SS}	-	0.2V _{DD}	V	-
	V _{IH}	0.8V _{DD}	-	V _{DD}	V	
Output voltage	V _{OL}	V _{SS}	-	0.2V _{DD}	V	
	V _{OH}	0.8V _{DD}	-	V _{DD}	V	
LCD driving voltage	V _{LCD}	9.3	9.5	9.7	V	

Note: VSS=0V。

7.2 Backlight Specifications (Ta=25°C)

Item	Symbol	Min	Typ	Max	Unit	Condition
Forward voltage	Vf(DC)	-	4.2	-	V	If=60mA
Color	Yellow-Green					

7.3 AC Characteristics

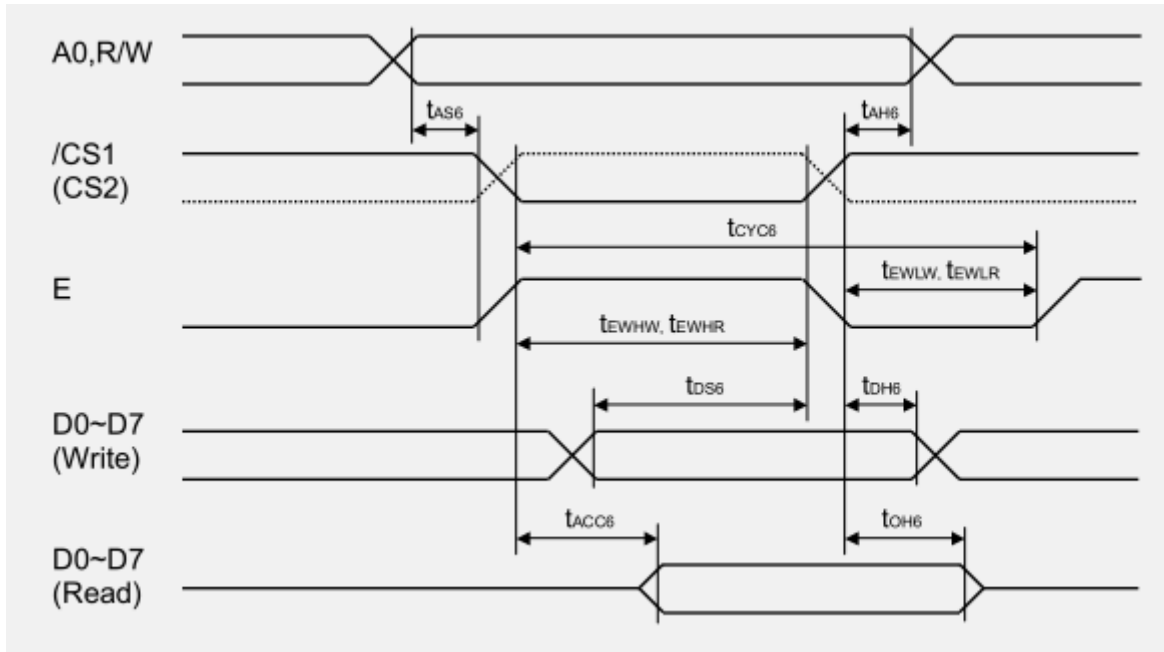

Symbol	Parameter	Min.	Typ.	Max.	Unit	Condition
t_{AH6}	Address hold time	0	-	-	ns	A0, R/W
t_{AS6}	Address setup time	0	-	-	ns	
t_{CYC6}	System cycle time	240	-	-	ns	
t_{EWHW}	Control high pulse width (write)	90	-	-	ns	E
t_{EWHR}	Control high pulse width (read)	120	-	-	ns	E
t_{EWLW}	Control low pulse width (write)	100	-	-	ns	E
t_{EWLR}	Control low pulse width (read)	60	-	-	ns	E
t_{DS6}	Data setup time	40	-	-	ns	D0~D7
t_{DH6}	Data hold time	10	-	-	ns	
t_{ACC6}	/RD access time	-	-	140	ns	D0~D7 CL = 100pF
t_{OH6}	Output disable time	5	-	50	ns	

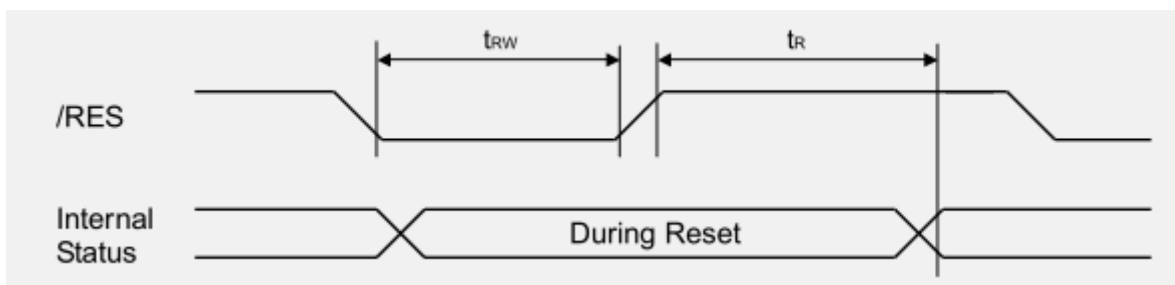

Symbol	Parameter	Min.	Typ.	Max.	Unit	Condition
t_R	Reset Time	-	-	1.0	μ s	
t_{RW}	Reset low pulse width	10	-	-	μ s	/RES

8 Instruction Description

Table 14. Command Table

Command	A0	/RD	/WR	Code								Hex	Function	
				D7	D6	D5	D4	D3	D2	D1	D0			
(1) Display OFF	0	1	0	1	0	1	0	1	1	1	0	1	A0h AFh	Turn on LCD panel when high, and turn off when low
(2) Display Start Line Set	0	1	0	0	1	Display Start Address					0	40h to 7Fh	Specifies RAM display line for COM0	
(3) Page Address Set	0	1	0	1	0	1	1	Page Address				0	B0h to B8h	Set the display data RAM page in Page Address register
(4) Column Address Set	0	1	0	0	0	0	1	Higher Column Address			0	00h to 18h	Set 4 higher bits and 4 lower bits of column address of display data RAM in register	
	0	1	0	0	0	0	0	Lower Column Address			0			
(5) Read Status	0	0	1	Status				0	0	0	0	0	XX	Reads the status information
(6) Write Display Data	1	1	0	Write Data								XX	Write data in display data RAM	
(7) Read Display Data	1	0	1	Read Data								XX	Read data from display data RAM	
(8) ADC Select	0	1	0	1	0	1	0	0	0	0	0	1	A0h A1h	Set the display data RAM address SEG output correspondence
(9) Normal/Reverse Display	0	1	0	1	0	1	0	0	1	1	0	1	A6h A7h	Normal indication when low, but full indication when high
(10) Entire Display ON/OFF	0	1	0	1	0	1	0	0	1	0	0	1	A4h A5h	Select normal display (0) or entire display on
(11) LCD Bias Set	0	1	0	1	0	1	0	0	0	1	0	1	A2h A3h	Sets LCD driving voltage bias ratio
(12) Read-Modify-Write	0	1	0	1	1	1	0	0	0	0	0	0	E0h	Increments column address counter during each write
(13) End	0	1	0	1	1	1	0	1	1	1	0	0	EEh	Releases the Read-Modify-Write
(14) Reset	0	1	0	1	1	1	0	0	0	1	0	0	E2h	Resets internal functions
(15) Common Output Mode Select	0	1	0	1	1	0	0	0	1	*	*	*	C0h to CFh	Select COM output scan direction *: invalid data
(16) Power Control Set	0	1	0	0	0	1	0	1	Operation Status			0	28h to 2Fh	Select the power circuit operation mode
(17) V0 Voltage Regulator Internal Resistor ratio Set	0	1	0	0	0	1	0	0	Resistor Ratio			0	20h to 27h	Select internal resistor ratio Rb/Ra mode
(18) Electronic Volume mode Set Electronic Volume Register Set	0	1	0	1	0	0	0	0	0	0	0	1	81h	
	0	1	0	*	*	Electronic Control Value					XX	Sets the V0 output voltage electronic volume register		
(19) Set Static indicator ON/OFF Set Static Indicator Register	0	1	0	1	0	1	0	1	1	0	0	1	ACh ADh	Sets static indicator ON/OFF 0: OFF, 1: ON
	0	1	0	*	*	*	*	*	*	Mode		XX	Sets the flash mode	
(20) Power Save	0	1	0	-	-	-	-	-	-	-	-	-	-	Compound command of Display OFF and Entire Display ON
(21) NOP	0	1	0	1	1	1	0	0	0	1	1	1	E3h	Command for non-operation

Command Table (continue)

Command	A0	/RD	/WR	Code								Hex	Function	
				D7	D6	D5	D4	D3	D2	D1	D0			
(22) Oscillation Frequency Select	0	1	0	1	1	1	0	0	1	0	0	1	E4h E5h	Select the oscillation frequency
(23) Partial Display mode Set	0	1	0	1	0	0	0	0	0	1	0	1	82h 83h	Enter/Release the partial display mode
(24) Partial Display Duty Set	0	1	0	0	0	1	1	0	Duty Ratio			0	30h 37h	Sets the LCD duty ratio for partial display mode
(25) Partial Display Bias Set	0	1	0	0	0	1	1	1	Bias Ratio			0	38h 3Fh	Sets the LCD bias ratio for partial display mode
(26) Partial Start Line Set	0	1	0	1	1	0	1	0	0	1	1	1	D3h	Enter Partial Start Line Set
Partial Start Line Set	0	1	0	1	1	Partial Start Line					XX	Sets the LCD Number of partial display start line		
(27) N-Line Inversion Set	0	1	0	1	0	0	0	0	1	0	0	1	85h	Enter N-Line inversion
Number of Line Set	0	1	0	*	*	*	Number of Line				XX	Sets the number of line used for N-Line inversion		
(28) N-Line Inversion Release	0	1	0	1	0	0	0	0	1	0	0	0	84h	Exit N-Line Inversion
(29) DC/DC Clock Set	0	1	0	1	1	1	0	0	1	1	0	0	E6h	Set DC/DC Clock Frequency
DC/DC Clock Division Set	0	1	0	1	1	0	0	Clock Division			XX	Set the Division of DC/DC Clock Frequency		
(30) Test Command	0	1	0	1	1	1	1	*	*	*	*	*	F1h to FFh	IC test command. Do not use!
(31) Test Mode Reset	0	1	0	1	1	1	1	0	0	0	0	0	F0h	Command of test mode reset

Note: Do not use any other command, or system malfunction may result.

9 QUALITY SPECIFICATIONS

9.1 Defect classification

Classify	Item		Note	AQL
Major	Display state	Short or open circuit	1	0.65
		Contrast defect (dim, ghost)		
		LC leakage		
		Flickering		
		No display		
		Wrong viewing direction	2	
		Wrong Back-light	7	
	Non-display	Flat cable or pin reverse	9	
		Wrong or missing component	10	
Minor	Display state	Background color deviation	2	1.5
		Black spot and dust	3	
		Line defect	4	
		Scratch		
		Rainbow	5	
		Pin hole	6	
	Polarizer	Bubble and foreign material	3	
		Scratch	4	
	PCB	Scratch	4	
	Soldering	Poor connection	8	
	Wire	Poor connection	9	

9.2 Note on defect classification

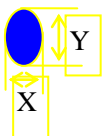
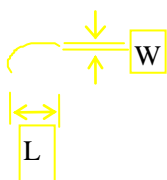
No.	Item	Criterion																				
1	Short or open circuit	Not allow																				
	LC leakage																					
	Flickering																					
	No display																					
	Wrong viewing direction																					
	Wrong Back-light																					
2	Contrast defect	Refer to approval sample																				
	Background color deviation																					
3	Point defect, Black spot, dust (incl. Polarizer) $\phi = (X+Y)/2$	 <table border="1" style="margin-left: auto; margin-right: auto;"> <thead> <tr> <th>Point Size</th> <th>Acceptable Qty.</th> </tr> </thead> <tbody> <tr> <td>$\phi \leq 0.10$</td> <td>Disregard</td> </tr> <tr> <td rowspan="2">$0.10 < \phi \leq 0.15$</td> <td>Positive:3</td> </tr> <tr> <td>Negative:2</td> </tr> <tr> <td rowspan="2">$0.15 < \phi \leq 0.2$</td> <td>Positive:2</td> </tr> <tr> <td>Negative:1</td> </tr> <tr> <td>$\phi > 0.2$</td> <td>0</td> </tr> </tbody> </table> <p style="text-align: right;">Unit: mm</p>	Point Size	Acceptable Qty.	$\phi \leq 0.10$	Disregard	$0.10 < \phi \leq 0.15$	Positive:3	Negative:2	$0.15 < \phi \leq 0.2$	Positive:2	Negative:1	$\phi > 0.2$	0								
Point Size	Acceptable Qty.																					
$\phi \leq 0.10$	Disregard																					
$0.10 < \phi \leq 0.15$	Positive:3																					
	Negative:2																					
$0.15 < \phi \leq 0.2$	Positive:2																					
	Negative:1																					
$\phi > 0.2$	0																					
4	Line defect	 <table border="1" style="margin-left: auto; margin-right: auto;"> <thead> <tr> <th colspan="2">Line</th> <th>Acceptable Qty.</th> </tr> <tr> <th>L</th> <th>W</th> <th></th> </tr> </thead> <tbody> <tr> <td>---</td> <td>$0.015 \geq W$</td> <td>Disregard</td> </tr> <tr> <td>$3.0 \geq L$</td> <td>$0.03 \geq W$</td> <td rowspan="2">2</td> </tr> <tr> <td>$2.0 \geq L$</td> <td>$0.05 \geq W$</td> </tr> <tr> <td>$1.0 \geq L$</td> <td>$0.1 > W$</td> <td>1</td> </tr> <tr> <td>---</td> <td>$0.05 < W$</td> <td>Applied as point defect</td> </tr> </tbody> </table> <p style="text-align: right;">Unit: mm</p>	Line		Acceptable Qty.	L	W		---	$0.015 \geq W$	Disregard	$3.0 \geq L$	$0.03 \geq W$	2	$2.0 \geq L$	$0.05 \geq W$	$1.0 \geq L$	$0.1 > W$	1	---	$0.05 < W$	Applied as point defect
Line		Acceptable Qty.																				
L	W																					
---	$0.015 \geq W$	Disregard																				
$3.0 \geq L$	$0.03 \geq W$	2																				
$2.0 \geq L$	$0.05 \geq W$																					
$1.0 \geq L$	$0.1 > W$	1																				
---	$0.05 < W$	Applied as point defect																				
5	Rainbow	Not more than two color changes across the viewing area.																				

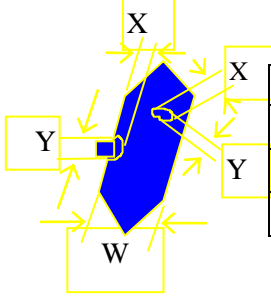
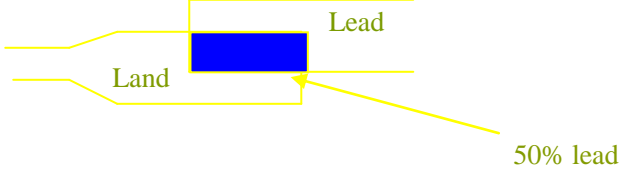
No.	Item	Criterion								
6	Segment pattern $W = \text{Segment width}$ $\phi = (X+Y)/2$	(1) Pin hole $\phi < 0.10\text{mm}$ is acceptable.  <table border="1" data-bbox="938 510 1394 680"> <thead> <tr> <th>Point Size</th> <th>Acceptable Qty</th> </tr> </thead> <tbody> <tr> <td>$\phi \leq 1/4W$</td> <td>Disregard</td> </tr> <tr> <td>$1/4W < \phi \leq 1/2W$</td> <td>1</td> </tr> <tr> <td>$\phi > 1/2W$</td> <td>0</td> </tr> </tbody> </table> <p style="text-align: right;">Unit: mm</p>	Point Size	Acceptable Qty	$\phi \leq 1/4W$	Disregard	$1/4W < \phi \leq 1/2W$	1	$\phi > 1/2W$	0
Point Size	Acceptable Qty									
$\phi \leq 1/4W$	Disregard									
$1/4W < \phi \leq 1/2W$	1									
$\phi > 1/2W$	0									
7	Back-light	(1) The color of backlight should correspond its specification. (2) Not allow flickering								
8	Soldering	(1) Not allow heavy dirty and solder ball on PCB. (The size of dirty refer to point and dust defect) (2) Over 50% of lead should be soldered on Land. 								
9	Wire	(1) Copper wire should not be rusted (2) Not allow crack on copper wire connection. (3) Not allow reversing the position of the flat cable. (4) Not allow exposed copper wire inside the flat cable.								
10	PCB	(1) Not allow screw rust or damage. (2) Not allow missing or wrong putting of component.								

11

LCD

2.1.1 chip on the surface

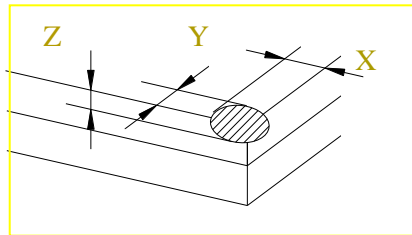
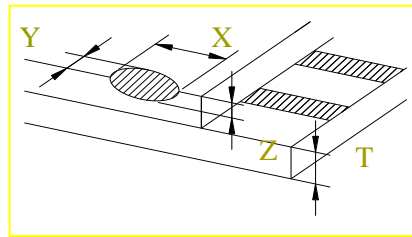
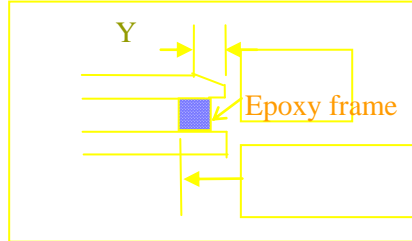
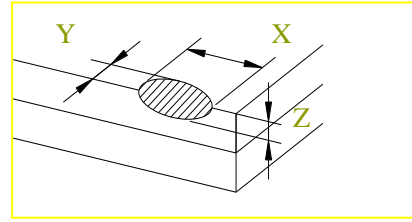

X	Y	Z
$>1/8A$	$\leq 0.3\text{mm}$	$\leq 1/2T$
$\leq 1/8A$	Not enter into epoxy frame	$\leq T$
	Not enter into the inner edge of epoxy	$\leq 1/2T$

11

LCD

2.1.2 chip on the terminal

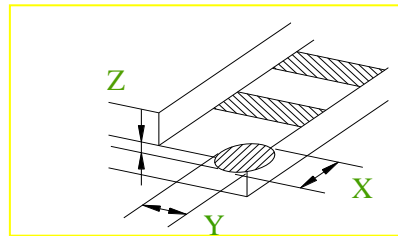
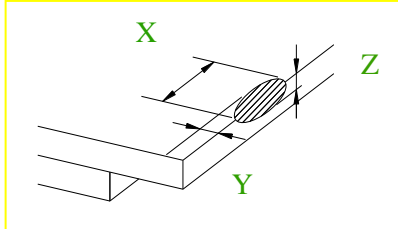
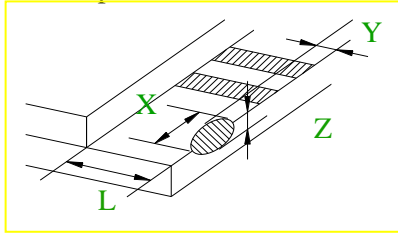

X	Y	Z
$>1/8A$	$\leq 0.3\text{mm}$	$\leq 1/2T$
$\leq 1/8A$	$\leq 1/2L$	$\leq T$
$\leq 1/8A$ 且 $\leq 1\text{mm}$	$\leq L$	$\leq T$
$\leq 1/8A$ 且 $\leq 2\text{mm}$	$\leq L$	$\leq 1/2T$

Note: the distance between crack and contact pad must be greater than the width of 1st contact pad

2.1.3 chip out on between side

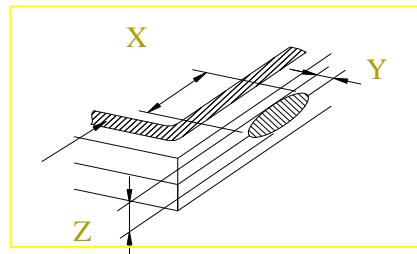

11

LCD

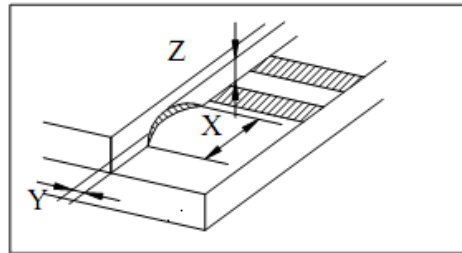
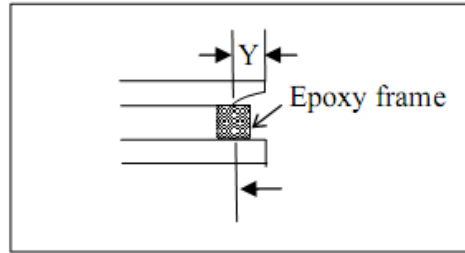

X	Y	Z
$\leq 1/8A$	Not enter into epoxy frame	$Z \leq 2T$
	Not enter into 1/2 epoxy frame	$Z \leq 1/2T$

2.1.4 including corner chip and side chip

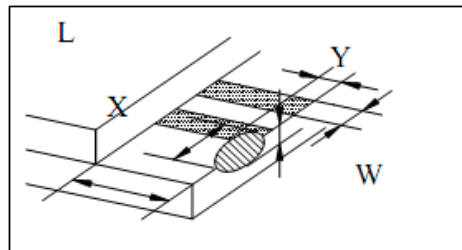

X	Y	Z
$>1/8A$	$\leq 1/6L$	$\leq 1/2T$
$\leq 1/8A$	$\leq 1/3L$	
$\leq 1/4W$	$\leq 2/3L$	

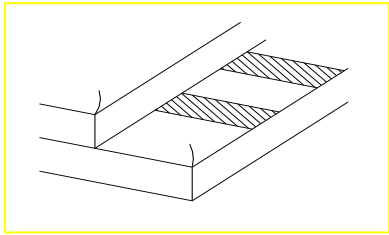
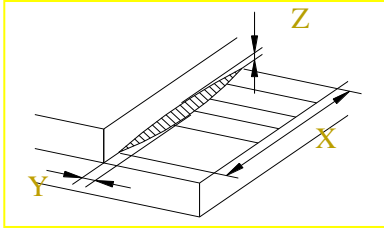
<p>11</p>	<p>LCD</p>	<p>2.2 Chip out</p>  <ol style="list-style-type: none"> 1) Chip out is that crackles extend to inner edge . 2) Crackles round epoxy frame will be rejected. 3) Chip out on the terminal will be rejected: $Z=T$ length $>1\text{mm}$ or $Z<T$ length $>2\text{mm}$ 4) The chip out at ITO will be rejected. 							
		<p>2.3 Poor cutting</p>  <table border="1" data-bbox="810 1225 1294 1422"> <thead> <tr> <th>X</th> <th>Y</th> <th>Z</th> </tr> </thead> <tbody> <tr> <td>$>1/8A$</td> <td>≤ 0.3</td> <td>$\leq 1/2T$</td> </tr> <tr> <td>$\leq 1/8A$</td> <td>According to drawing</td> <td>$1/2T \leq Z \leq T$</td> </tr> </tbody> </table> <p>Any one out of the specification will be rejected.</p>	X	Y	Z	$>1/8A$	≤ 0.3	$\leq 1/2T$	$\leq 1/8A$
X	Y	Z							
$>1/8A$	≤ 0.3	$\leq 1/2T$							
$\leq 1/8A$	According to drawing	$1/2T \leq Z \leq T$							

9.3. Reliability of LCM

Reliability test condition:

Item	Condition	Time (hrs)	Assessment
High temp. Storage	+70°C	72	No abnormalities in functions and appearance
High temp. Operating	+70°C	72	
Low temp. Storage	-40°C	72	
Low temp. Operating	-20°C	72	
Humidity	40°C/ 90%RH	72	
Temp. Cycle	-20°C ← 25°C → +70°C (1 hour ← 5 min → 1 hour)	10cycles	

10 DESCRIBE TO THE PART NO:

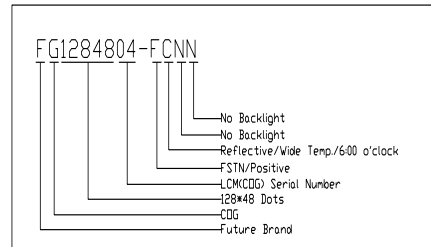

11 GUARANTEE

Our products could meet requirements of the environment. Future's RoHS is introduced European Union Directive 200295EC (RoHS) Requirements and Update.