

飞优特科技（深圳）有限公司

FUTURE S&T(SHEN ZHEN)CO.,LTD

Approval Sheet

Customer : _____ Part No.: FB12864GL-FGBW-02

Sample Approved: _____ Sample Quantity: _____

Sample Date: _____

1:Outlook

Items	Description	Result	
Outer Dimension	Length、 Width、 Height、 Positioning Hole、 I/O Position	<input type="checkbox"/> OK	<input type="checkbox"/> NG
LCD Color	LCD Background Color	<input type="checkbox"/> OK	<input type="checkbox"/> NG
LED Color	LED Lighting Color	<input type="checkbox"/> OK	<input type="checkbox"/> NG
Others	Customer Additional Request	<input type="checkbox"/> OK	<input type="checkbox"/> NG
Outlook Description:			

2:Electrical Characteristics

Items	Description	Result	
LCD Voltage	LCD Driving Voltage:VLCD	<input type="checkbox"/> OK	<input type="checkbox"/> NG
Viewing Angle	LCD Operating Viewing Angle	<input type="checkbox"/> OK	<input type="checkbox"/> NG
LCM Current Consumption	LCM current consumption satisfy customer request	<input type="checkbox"/> OK	<input type="checkbox"/> NG
LED Current Consumption	LED lighting Current Consumption satisfy customer request	<input type="checkbox"/> OK	<input type="checkbox"/> NG
Electrical Characteristics Description:			

Conclusion: **Can go to M/P according to samples**
 Need to be revised according to above description

Approved By:		Verified By:	
-------------------------------	--	-------------------------------	--

CONTENTS

1 FUNCTION & FEATURES	1
2 BLOCK DIAGRAM.....	1
3 DIMENSIONAL CD DRAWING	2
4 POWER SUPPL	3
5 PIN DESCRIPTION	3
6 MAXIMUM ABSOLUTE LIMIT (T=25°C)	4
7 ELECTRICAL CHARACTERISTICS	4
7.1DC Characteristics(T=25°C)	4
7.2 AC Characteristics	5
7.3 Timing Characteristics.....	5
8 Instruction Description	6
9 QUALITY SPECIFICATIONS.....	8
9.1 Defect classification.....	8
9.2 Note on defect classification	9
9.3. Reliability of LCM.....	15
10.DESCRIBE TO THE PART NO:	15
11.GUARRANTEE	15



1 FUNCTION & FEATURES

ITEM	Normal dimensions
Display Format	128*64 DOTS
Module dimension	93.0(W)*70.0(H)*13.0 (T_MAX) mm
Viewing area	73.0 (W)*39.0(H) mm
Duty/bias	1/64Duty,1/9Bias
LCD mode	FSTN/Positive /Transflective
Viewing direction	6:00 O'clock

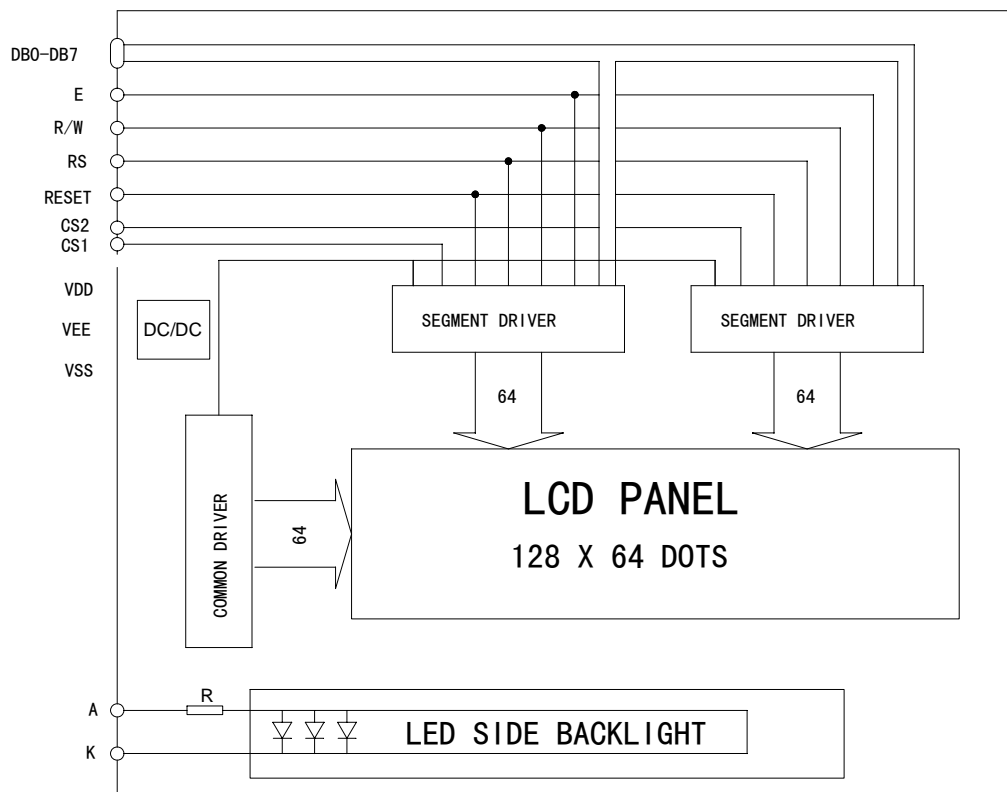
2 BLOCK DIAGRAM

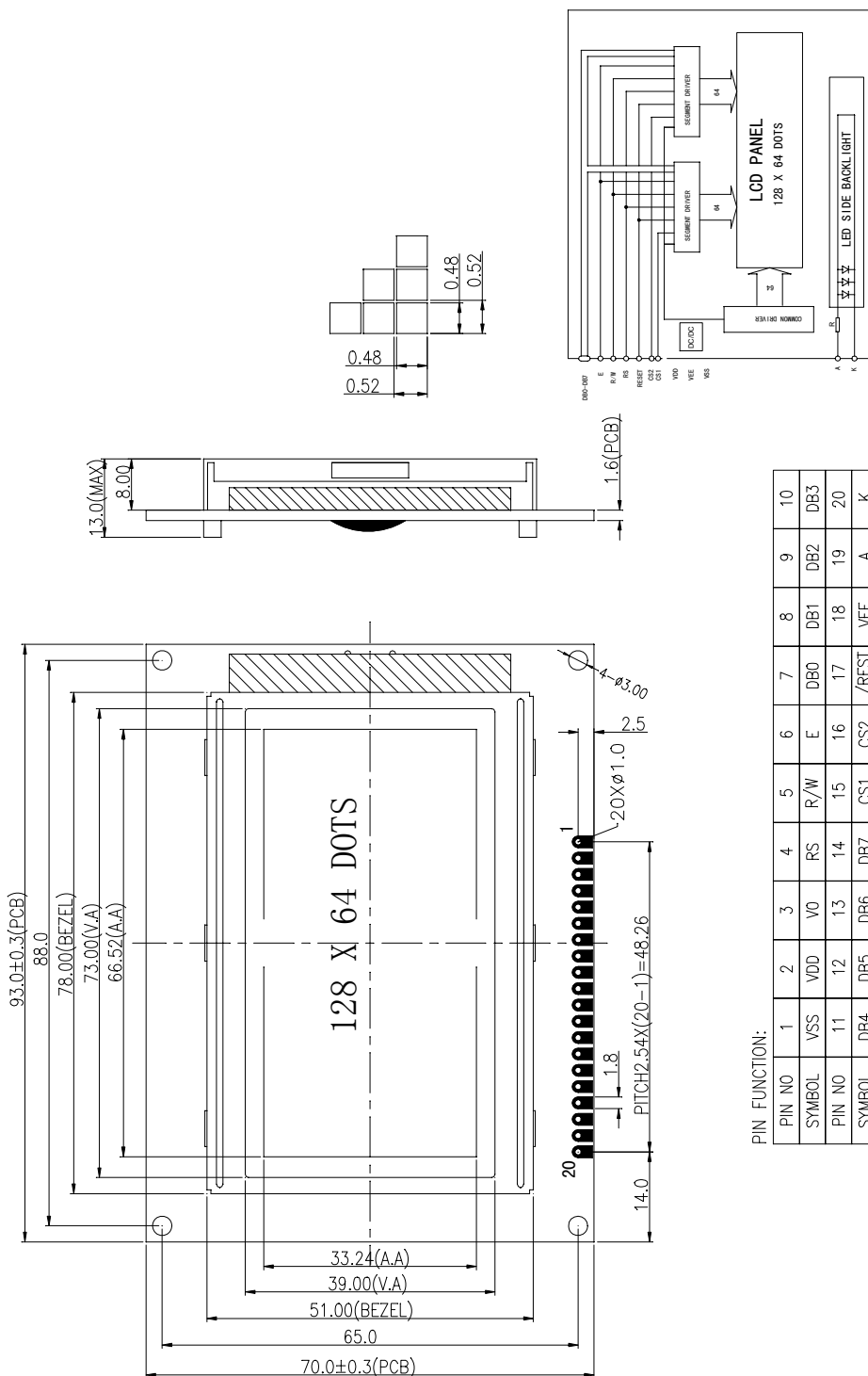

3 DIMENSIONAL CD DRAWING

Customer No.:	Customer Approve By:	REV. A0	DESCRIPTION OF MODIFY 1. ST DESIGN	MODIFY BY: DZH	DATE 2016-05-17																																												
																																																	
<p>128 X 64 DOTS</p>																																																	
<table border="1" style="margin: auto;"> <thead> <tr> <th>PIN NO</th><th>1</th><th>2</th><th>3</th><th>4</th><th>5</th><th>6</th><th>7</th><th>8</th><th>9</th><th>10</th> </tr> </thead> <tbody> <tr> <td>SYMBOL</td><td>VSS</td><td>VDD</td><td>R/W</td><td>RS</td><td>DB7</td><td>CS1</td><td>DB6</td><td>DB5</td><td>DB4</td><td>DB3</td> </tr> <tr> <td>PIN NO</td><td>11</td><td>12</td><td>13</td><td>14</td><td>15</td><td>16</td><td>17</td><td>18</td><td>19</td><td>20</td> </tr> <tr> <td>SYMBOL</td><td>DB4</td><td>DB5</td><td>DB6</td><td>DB7</td><td>CS1</td><td>CS2</td><td>/REST</td><td>VEE</td><td>A</td><td>K</td> </tr> </tbody> </table>						PIN NO	1	2	3	4	5	6	7	8	9	10	SYMBOL	VSS	VDD	R/W	RS	DB7	CS1	DB6	DB5	DB4	DB3	PIN NO	11	12	13	14	15	16	17	18	19	20	SYMBOL	DB4	DB5	DB6	DB7	CS1	CS2	/REST	VEE	A	K
PIN NO	1	2	3	4	5	6	7	8	9	10																																							
SYMBOL	VSS	VDD	R/W	RS	DB7	CS1	DB6	DB5	DB4	DB3																																							
PIN NO	11	12	13	14	15	16	17	18	19	20																																							
SYMBOL	DB4	DB5	DB6	DB7	CS1	CS2	/REST	VEE	A	K																																							
<p>PIN FUNCTION:</p>																																																	
<p>Note:</p> <ol style="list-style-type: none"> 1. Display Mode: FSTN/POSITIVE/TRANSFLECTIVE 2. Driving Condition: 1/64Duty, 1/9Bias; VDD=3.3V, VLCD=9.0V 3. Viewing Direction: 6:00 o'clock 4. Operating Temp: -20~+70°C 5. Storage Temp: -30~+80°C 6. Backlight: COB/Driver IC: SBN6400G+SBN0064G*2 7. Dimensions with mark "()" are referenced. 8. Unspecified tolerance is ±0.20mm 9. ROHS Request 																																																	
 <p>飞优特科技(深圳)有限公司 FUTURE S&T (SHEN ZHEN) CO., LTD TEL: +86-755-29675886. FAX: +86-755-29675655 E-mail: sales@futurelcd.com</p>		 <p>CD</p>		<p>UNIT: MM SIZE: A4</p> <p>SHEET: 1 OF 1</p>																																													
<p>LCM NO. : FB12864GL-FGBW-02</p>		<p>DWG NO. : FB12864GL-FGBW-02-CD</p>		<p>REV: A0</p>																																													
DRAWN BY :		CHECKED BY :		APPROVED BY :																																													

4 POWER SUPPL

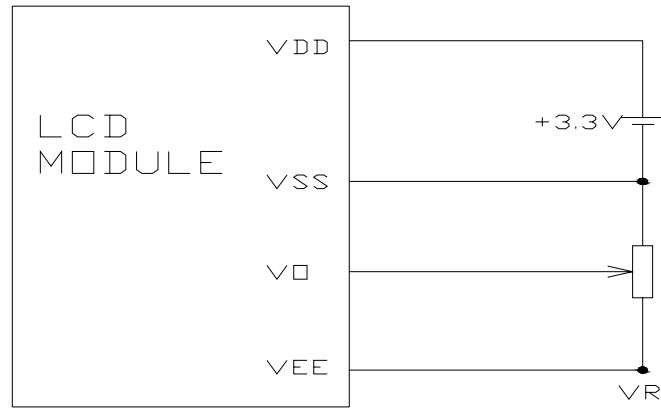

VDD-VO: LCD Driving Voltage
 VR: 10K-20K

5 PIN DESCRIPTION

PIN	SYMBOL	FUNCTION
1	VSS	Power Supply(0V,GND)
2	VDD	Power Supply For Logic(+3.3V)
3	Vo	Contrast Adjust
4	RS	Instruction/Data Register Select
5	R/W	Data Read/Write
6	E	Enable Signal
7-14	DB0-DB7	Data Bus Line
15	CS1	Chip select for IC1 H Active
16	CS2	Chip select for IC2 H Active
17	/REST	Reset Signal
18	VEE	Negative Voltage
19	A	Power Supply For LED BL(+3.0V)
20	K	Power Supply For LED BL(0V,GND)

6 MAXIMUM ABSOLUTE LIMIT (T=25°C)

Item	Symbol	Standard value	Unit
Supply voltage	V _{DD}	0 ∞ +7.0	V
Input voltage	V _{LCD}	0 ∞ 18.0	V
Operating temperature	Topr	-20~+70	°C
Storage temperature	Tstg	-30~+80	°C

Note: Voltage greater than above may damage the module. All voltages are specified relative to VSS=0V.

7 ELECTRICAL CHARACTERISTICS

7.1DC Characteristics(T=25°C)

Item	Symbol	Min	Typ	Max	Unit	Applicable terminal	Test condition
LCD logic circuit supply voltage	V _{DD}	3.0	3.3	3.6	V	-	Ta=25°C
LCD supply current	I _{DD}	-	1	3	mA	-	
LCD input voltage	V _{IL}	0	-	0.6	V	-	
	V _{IH}	0.7 V _{DD}	-	V _{DD}	V		
LCD output voltage	V _{OL}	-	-	0.2 V _{DD}	V	-	
	V _{OH}	0.75 V _{DD}	-	-	V		
LCD driving voltage	V _{LCD}	8.6	9.0	9.4	V	VDD-V0	
Backlight supply current	I _f	-	45	60	mA	Vak=3.0	
Power dissipation(B/L)	Pd			380	mW		
LED life time (For Referenceonly)	35K				Hr.	I _f =45mA, 50-60% RH) (Note 1. Note 2)	

*For operation above 25°C, the I_f, I_{fp}&P_d must be derated, the current derating is -1.08mA/°C for DC drive and -2.08 mA/°C for pulse drive, the power dissipation is -3.24 mW /°C. The Backlight working current must not more than 60% of the I_{fmax} or I_{fpmax} according to the working temperature.

Note 1: The LED of B/L is drive by current only, drive voltage is for reference only. drive voltage can make driving current under safety area (current between minimum and maximum).

Note 2 :35K hours is only a estimate for reference.

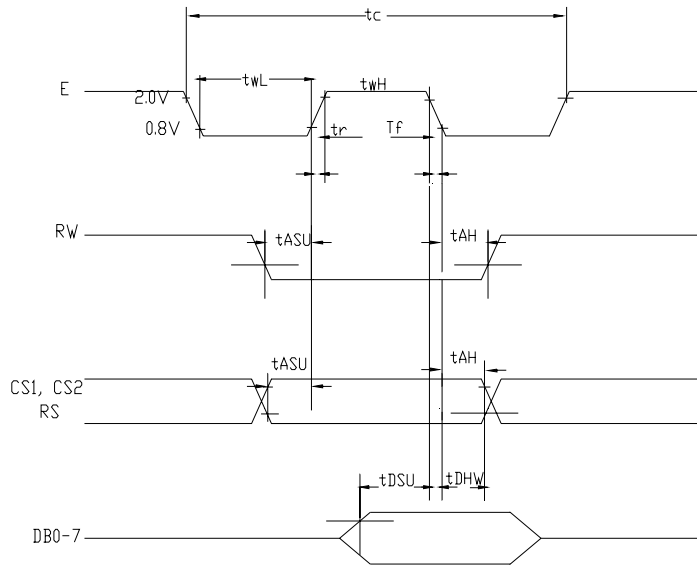
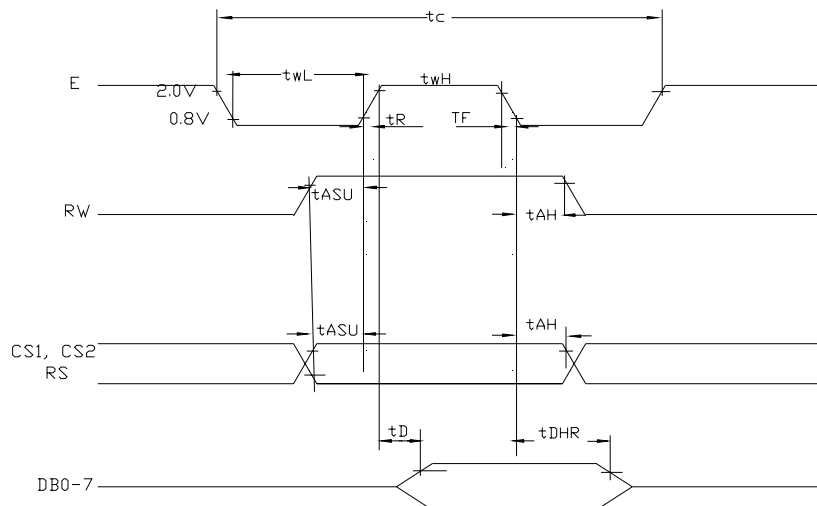
7.2 AC Characteristics
MPU WRITE TIMING

MPU READ TIMING

7.3 TIMING SPECIFICATIONS at Ta = 25 deg C, Vdd = 5V +/- 10%, Vss = 0V

ITEM	SYMBOL	MIN	MAX	UNIT
E Cycle Time	tc	1000	-	ns
E High Level Width	tWH	450		ns
E Low Level Width	tWL	450		ns
E rise time	tR	-	25	ns
E fall time	tF	-	25	ns
Address Set-Up Time	tASU	140	-	ns
Address Hold Time	tAH	10	-	ns
Data Set-up Time	tDSU	200	-	ns
Data Delay Time	tD	-	320	ns
Data Hold Time(Write)	tDHW	10		ns
Data Hold Time(Read)	tDHR	20		ns

8 Instruction Description

Instruction	RS	R/W	DB7	DB6	DB5	DB4	DB3	DB2	DB1	DB0	Function	
Display ON/OFF	L	L	L	L	H	H	H	H	H	L/H	Controls the display on or off. Internal status and display RAM data is not affected. L: OFF, H: ON	
Set Address (Y address)	L	L	L	H	Y address (0~63)						Sets the Y address in the Y address counter.	
Set Page (X address)	L	L	H	L	H	H	H	Page (0~7)			Sets the X address at the X address register.	
Display Start Line (Z address)	L	L	H	H	Display start line (0~63)						Indicates the display data RAM displayed at the top of the screen.	
Status Read	L	H	B U S Y	L	O N / O F F	R E S E T	L	L	L	L	Read status. BUSY L: Ready H: In operation ON/OFF L: Display ON H: Display OFF RESET L: Normal H: Reset	
Write Display Data	H	L	Write Data									Writes data (DB0:7) into display data RAM. After writing instruction, Y address is increased by 1 automatically.
Read Display Data	H	H	Read Data									Reads data (DB0:7) from display data RAM to the data bus.

1. Display On/Off

RS	R/W	DB7	DB6	DB5	DB4	DB3	DB2	DB1	DB0
0	0	0	0	1	1	1	1	1	D

The display data appears when D is 1 and disappears when D is 0.
Though the data is not on the screen with D=0, it remains in the display data RAM.
Therefore, you can make it appear by changing D=0 into D=1.

2. Set Address (Y Address)

S	R/W	DB7	DB6	DB5	DB4	DB3	DB2	DB1	DB0
0	0	0	1	AC5	AC4	AC3	AC2	AC1	AC0

Y address (AC0 ~ AC5) of the display data RAM is set in the Y address counter.
An address is set by instruction and increased by 1 automatically by read or write operations of display data.

3. Set Page (X Address)

RS	R/W	DB7	DB6	DB5	DB4	DB3	DB2	DB1	DB0
0	0	1	0	1	1	1	AC2	AC1	AC0

X address (AC0 ~ AC2) of the display data RAM is set in the X address register.
Writing or reading to or from MPU is executed in this specified page until the next page is set.

4. Display Start Line (Z Address)

RS	R/W	DB7	DB6	DB5	DB4	DB3	DB2	DB1	DB0
0	0	1	1	AC5	AC4	AC3	AC2	AC1	AC0

Z address (AC0 ~ AC5) of the display data RAM is set in the display start line register and displayed at the top of the screen.

When the display duty cycle is 1/64 or others(1/32 ~ 1/64), the data of total line number of LCD screen, from the line specified by display start line instruction, is displayed.

5. Status Read

RS	R/W	DB7	DB6	DB5	DB4	DB3	DB2	DB1	DB0
1	0	BUSY	0	ON/OFF	RESET	0	0	0	0

- **BUSY**
When BUSY is 1, the Chip is executing internal operation and no instructions are accepted.
When BUSY is 0, the Chip is ready to accept any instructions.
- **ON/OFF**
When ON/OFF is 1, the display is on.
When ON/OFF is 0, the display is off.
- **RESET**
When RESET is 1, the system is being initialized.
In this condition, no instructions except status read can be accepted.
When RESET is 0, initializing has finished and the system is in the usual operation condition.

6. Write Display Data

RS	R/W	DB7	DB6	DB5	DB4	DB3	DB2	DB1	DB0
0	1	D7	D6	D5	D4	D3	D2	D1	D0

Writes data (D0 ~ D7) into the display data RAM.

After writing instruction, Y address is increased by 1 automatically.

7. Read Display Data

RS	R/W	DB7	DB6	DB5	DB4	DB3	DB2	DB1	DB0
1	1	D7	D6	D5	D4	D3	D2	D1	D0

Reads data (D0 ~ D7) from the display data RAM.

After reading instruction, Y address is increased by 1 automatically.

***Please refer to the IC specification of KS0108B&KS0107B OR SBN6400G&SBN0064G**

9 QUALITY SPECIFICATIONS

9.1 Defect classification

Classify	Item		Note	AQL
Major	Display state	Short or open circuit	1	0.4
		Contrast defect (dim, ghost)		
		LC leakage		
		Flickering		
		No display		
		Wrong viewing direction	2	
		Wrong Back-light	7	
	Non-display	Flat cable or pin reverse	9	
Wrong or missing component		10		
Minor	Display state	Background color deviation	2	1.0
		Black spot and dust	3	
		Line defect	4	
		Scratch		
		Rainbow	5	
		Pin hole	6	
	Polarizer	Bubble and foreign material	3	
		Scratch	4	
	PCB	Scratch	4	
	Soldering	Poor connection	8	
	Wire	Poor connection	9	

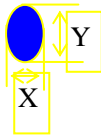
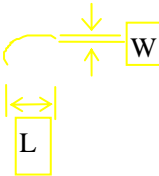

9.2 Note on defect classification

No.	Item	Criterion																				
1	Short or open circuit	Not allow																				
	LC leakage																					
	Flickering																					
	No display																					
	Wrong viewing direction																					
	Wrong Back-light																					
2	Contrast defect	Refer to approval sample																				
	Background color deviation																					
3	Point defect, Black spot, dust (incl. Polarizer) $\phi = (X+Y)/2$	 <table border="1" data-bbox="917 878 1353 1164"> <thead> <tr> <th>Point Size</th> <th>Acceptable Qty.</th> </tr> </thead> <tbody> <tr> <td>$\phi \leq 0.10$</td> <td>Disregard</td> </tr> <tr> <td rowspan="2">$0.10 < \phi \leq 0.15$</td> <td>Positive:4</td> </tr> <tr> <td>Negative:3</td> </tr> <tr> <td rowspan="2">$0.15 < \phi \leq 0.2$</td> <td>Positive:3</td> </tr> <tr> <td>Negative:2</td> </tr> <tr> <td>$\phi > 0.2$</td> <td>0</td> </tr> </tbody> </table> <p style="text-align: right;">Unit: mm</p>	Point Size	Acceptable Qty.	$\phi \leq 0.10$	Disregard	$0.10 < \phi \leq 0.15$	Positive:4	Negative:3	$0.15 < \phi \leq 0.2$	Positive:3	Negative:2	$\phi > 0.2$	0								
Point Size	Acceptable Qty.																					
$\phi \leq 0.10$	Disregard																					
$0.10 < \phi \leq 0.15$	Positive:4																					
	Negative:3																					
$0.15 < \phi \leq 0.2$	Positive:3																					
	Negative:2																					
$\phi > 0.2$	0																					
4	Line defect	 <table border="1" data-bbox="845 1317 1396 1572"> <thead> <tr> <th colspan="2">Line</th> <th>Acceptable Qty.</th> </tr> <tr> <th>L</th> <th>W</th> <th></th> </tr> </thead> <tbody> <tr> <td>---</td> <td>$0.015 \geq W$</td> <td>Disregard</td> </tr> <tr> <td>$3.0 \geq L$</td> <td>$0.03 \geq W$</td> <td rowspan="2">2</td> </tr> <tr> <td>$2.0 \geq L$</td> <td>$0.05 \geq W$</td> </tr> <tr> <td>$1.0 \geq L$</td> <td>$0.1 > W$</td> <td>1</td> </tr> <tr> <td>---</td> <td>$0.05 < W$</td> <td>Applied as point defect</td> </tr> </tbody> </table> <p style="text-align: right;">Unit: mm</p>	Line		Acceptable Qty.	L	W		---	$0.015 \geq W$	Disregard	$3.0 \geq L$	$0.03 \geq W$	2	$2.0 \geq L$	$0.05 \geq W$	$1.0 \geq L$	$0.1 > W$	1	---	$0.05 < W$	Applied as point defect
Line		Acceptable Qty.																				
L	W																					
---	$0.015 \geq W$	Disregard																				
$3.0 \geq L$	$0.03 \geq W$	2																				
$2.0 \geq L$	$0.05 \geq W$																					
$1.0 \geq L$	$0.1 > W$	1																				
---	$0.05 < W$	Applied as point defect																				
5	Rainbow	Not more than two color changes across the viewing area.																				

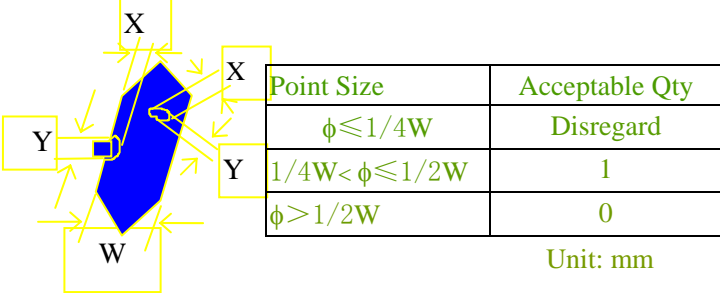
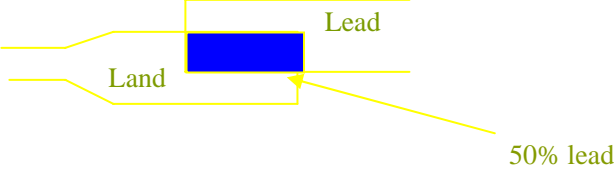

No.	Item	Criterion								
6	Segment pattern $W = \text{Segment width}$ $\phi = (X+Y)/2$	(1) Pin hole $\phi < 0.10\text{mm}$ is acceptable.  <table border="1" data-bbox="911 510 1369 680"> <thead> <tr> <th>Point Size</th> <th>Acceptable Qty</th> </tr> </thead> <tbody> <tr> <td>$\phi \leq 1/4W$</td> <td>Disregard</td> </tr> <tr> <td>$1/4W < \phi \leq 1/2W$</td> <td>1</td> </tr> <tr> <td>$\phi > 1/2W$</td> <td>0</td> </tr> </tbody> </table> <p style="text-align: right;">Unit: mm</p>	Point Size	Acceptable Qty	$\phi \leq 1/4W$	Disregard	$1/4W < \phi \leq 1/2W$	1	$\phi > 1/2W$	0
Point Size	Acceptable Qty									
$\phi \leq 1/4W$	Disregard									
$1/4W < \phi \leq 1/2W$	1									
$\phi > 1/2W$	0									
7	Back-light	(1) The color of backlight should correspond its specification. (2) Not allow flickering								
8	Soldering	(1) Not allow heavy dirty and solder ball on PCB. (The size of dirty refer to point and dust defect) (2) Over 50% of lead should be soldered on Land. 								
9	Wire	(1) Copper wire should not be rusted (2) Not allow crack on copper wire connection. (3) Not allow reversing the position of the flat cable. (4) Not allow exposed copper wire inside the flat cable.								
10	PCB	(1) Not allow screw rust or damage. (2) Not allow missing or wrong putting of component.								

11

LCD

2.1.1 chip on the surface

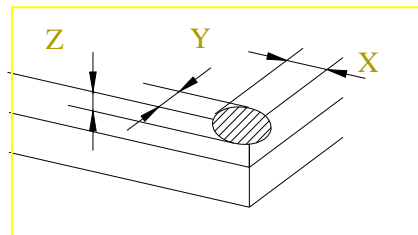
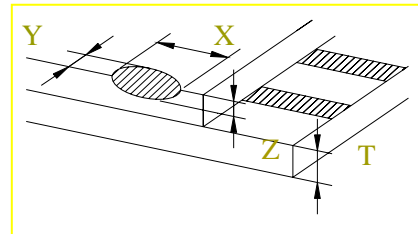
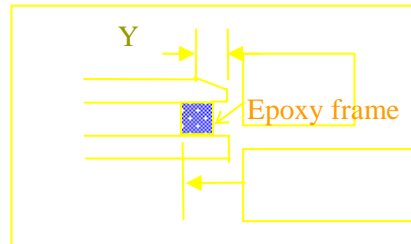
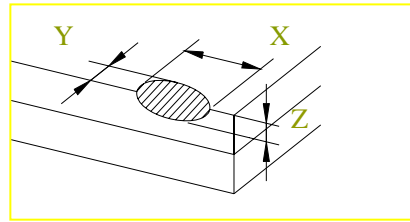

X	Y	Z
$>1/8A$	$\leq 0.3\text{mm}$	$\leq 1/2T$
$\leq 1/8A$	Not enter into epoxy frame	$\leq T$
	Not enter into the inner edge of epoxy	$\leq 1/2T$

11

LCD

2.1.2 chip on the terminal

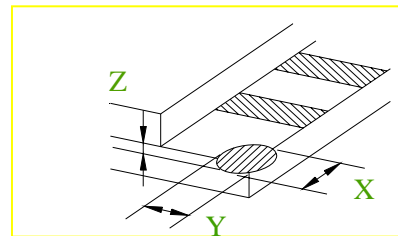
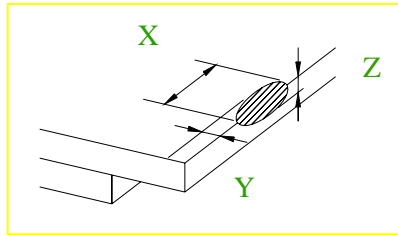
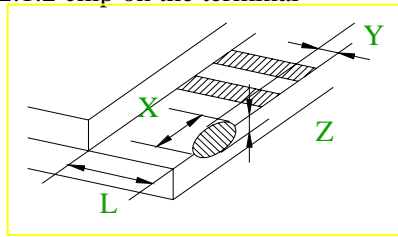

X	Y	Z
$>1/8A$	$\leq 0.3\text{mm}$	$\leq 1/2T$
$\leq 1/8A$	$\leq 1/2L$	$\leq T$
$\leq 1/8A$ 且 $\leq 1\text{mm}$	$\leq L$	$\leq T$
$\leq 1/8A$ 且 $\leq 2\text{mm}$	$\leq L$	$\leq 1/2T$

Note: the distance between crack and contact pad must be greater than the width of 1st contact pad

2.1.3 chip out on between side

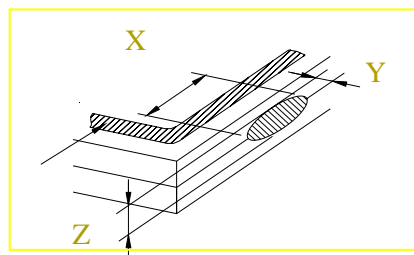

11

LCD

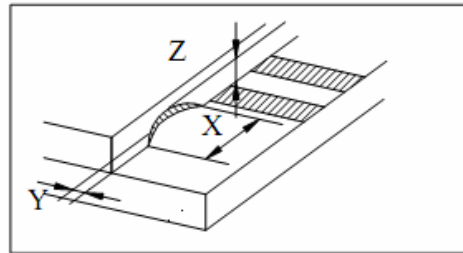
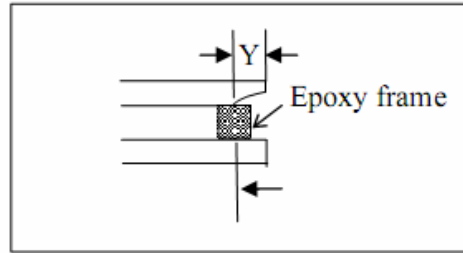

X	Y	Z
$\leq 1/8A$	Not enter into epoxy frame	$Z \leq 2T$
	Not enter into 1/2 epoxy frame	$Z \leq 1/2T$

2.1.4 including corner chip and side chip

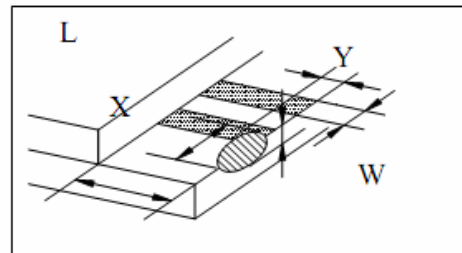

X	Y	Z
$> 1/8A$	$\leq 1/6L$	$\leq 1/2T$
$\leq 1/8A$	$\leq 1/3L$	
$\leq 1/4W$	$\leq 2/3L$	



11

LCD

2.2 Chip out

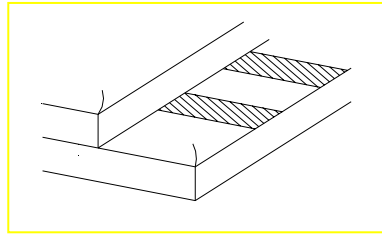

- 1) Chip out is that crackles extend to inner edge .
- 2) Crackles round epoxy frame will be rejected.
- 3) Chip out on the terminal will be rejected: $Z=T$
length >1mm
or $Z<T$ length >2mm
- 4) The chip out at ITO will be rejected.

2.3 Poor cutting

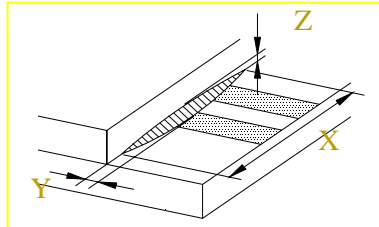

X	Y	Z
>1/8A	≤0.3	≤1/2T
≤1/8A	According to drawing	1/2T ≤ Z ≤ T

Any one out of the specification will be rejected.

9.3. Reliability of LCM

Reliability test condition:

Item	Condition	Time (hrs)	Assessment
High temp. Storage	+80°C	72	No abnormalities in functions and appearance
High temp. Operating	+70°C	72	
Low temp. Storage	-30°C	72	
Low temp. Operating	-20°C	72	
Humidity	40°C/ 90%RH	72	
Temp. Cycle	-20°C ← 25°C → +70°C (1 hour ← 5 min → 1 hour)	10cycles	

10.DESCRIBE TO THE PART NO:

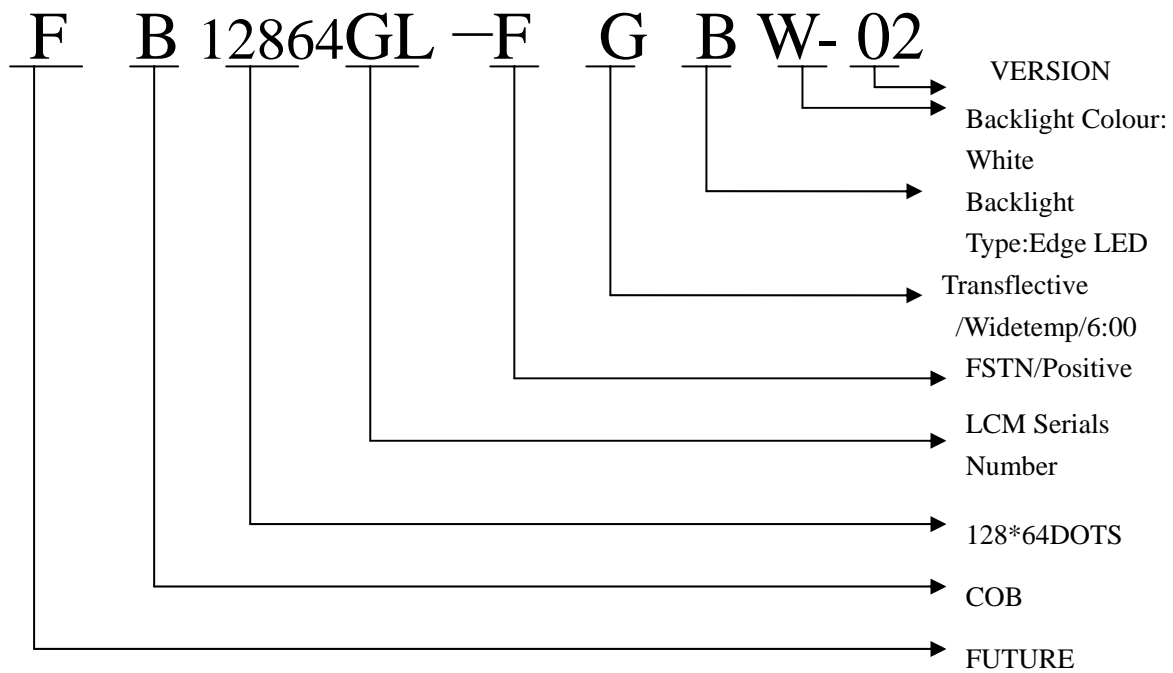

11.GUARRANTEE

Our products could meet requirements of the environment. Future's RoHS is introduced European Union Directive 2002/95/EC (RoHS) Requirements and Update.