

PRODUCT SPECIFICATION

CS2004C-D-YSXFSWN-100

VI.2

June 20, 2012

 Eastertronic LCD Group

REVISION RECORD

REV	Description	Page	Date
V1.0	First Release		May 24, 2011
V1.1	Showed the Vo circuit,the 10K and the resistor C7 to adjust the Vop, and the C7 is free to be changed to adjust the contrast.	10	May 12,2012
V1.2	Change the resistor to a trimmer on C7 pads	10	June 20,2012



CONTENTS

SECTIONS	DESCRIPTION	PAGE NO.
1.	LCD Module Numbering System.....	4
2.	Type Number And Description.....	4
3.	Mechanical Specifications	6
4.	Electrical Block Diagram	7
4.1	Pin Definition.....	7
4.2	Electrical Block Diagram	7
4.3	Display Character Address Code	7
5.	Absolute Maximum Ratings	7
5.1	Electrical Maximum Ratings	8
5.2	Environmental Conditions	8
6.	ELECTRICAL SPECIFICATIONS	8
6.1	Electrical Characteristics	8
6.2	Timing Specifications.....	8
7.	Power Supply For LCD Module	10
8.	Electro-Optical Characteristic.....	10
9.	Instruction Table.....	12
10.	Initialization By Instruction	13
11.	Software Examples.....	14
12.	Quality units	15
13.	Precaution For Using LCM.....	25
14.	Declaration of conformity regarding the limitation of dangerous substances	26

1. Type Number And Description

Type Number	:	CS2004C-D-YSXFSWN-100
Description	:	20Characters X 4Lines
LCD Panel	:	Yellow-Green STN, positive,Transflective
Viewing angle	:	6H
Duty	:	1/16
Bias	:	1/5
Operating Temperature:		-20°C – 70°C
Storage Temperature	:	-30°C – 80°C
Controller	:	ST7066U-0A Or Equivalent
IC package	:	Bonding
BackLight	:	White LED, Side

2. LCD Module Numbering System



3. Mechanical Specifications

ITEM	STANDARD VALUE	UNIT
NUMBER OF CHARACTERS	20 CHARACTERS X 4LINES	
CHARACTER FORMAT	5 X 8 DOTS	
MODULE DIMENSION	146.0(W) X 62.5(H) X 13.0(T)	mm
EFFECTTVE DISPLAY AREA	123.5(W) X 43.0(H)	mm
CHARACTER SIZE	4.84(W) X 9.22(H)	mm
CHARACTER PITCH	6.0(W) X 9.75(H)	mm
DOT SIZE	0.92(W) X 1.1(H)	mm
DOT PITCH	0.98(W) X 1.16(H)	mm
APPROX WEIGHT	118	g
LCD TYPE	Yellow-Green STN, TRANSFLECTIVE	
DUTY AND BIAS	1/16 DUTY; 1/5 BIAS	
VIEWING DIRECTION	6:00	
BACK LIGHT	WHITE LED, SIDE	

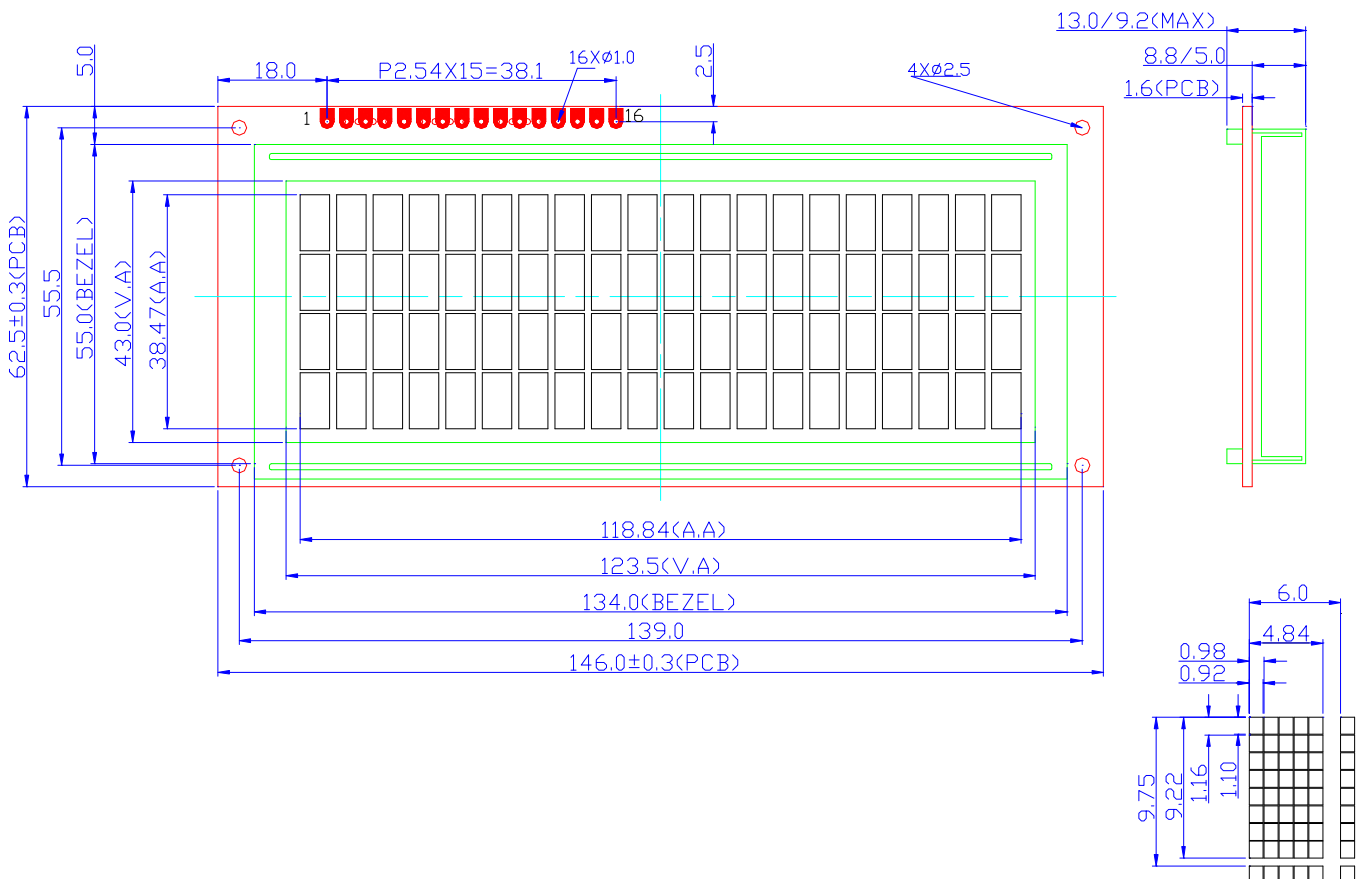

* Remark : General tolerance refers this model. (±0.2mm)

4. Electrical Block Diagram

4.1 Pin Definition

PIN	SYMBOL	FUNCTION
1	Vss	Power Supply(GND)
2	Vdd	Power Supply(+5V)
3	Vo	Contrast Adjust
4	RS	Instruction/Data Register Select
5	R/W	Data Read/Write
6	E	Enable Signal
7-14	DB0-DB7	Data Bus Line
15	A	Power Supply For LED BL(+)
16	K	Power Supply For LED BL(-)

4.2 Electrical Block Diagram

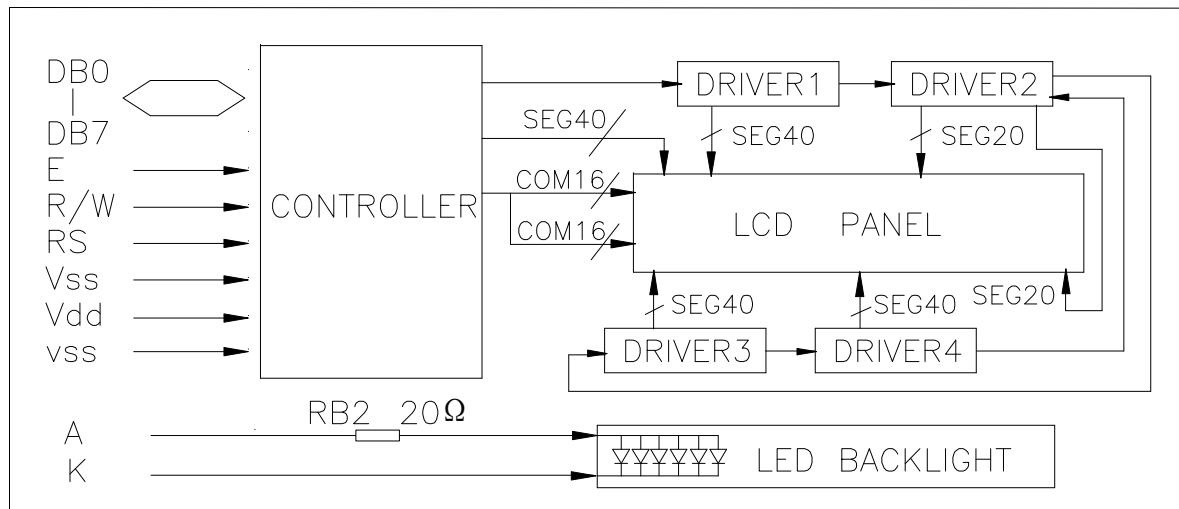

4.3 Display Character Address Code

DISPLAY POSITION	1	2	3	4	5	6	7	8	9	10	11	12	13	14	15	16	17	18	19	20
DDRAM ADDRESS	00	01	02	03	04	05	06	07	08	09	0A	0B	0C	0D	0E	0F	10	11	12	13
	40	41	42	43	44	45	46	47	48	49	4A	4B	4C	4D	4E	4F	50	51	52	53
	14	15	16	17	18	19	1A	1B	1C	1D	1E	1F	20	21	22	23	24	25	26	27
	54	55	56	57	58	59	5A	5B	5C	5D	5E	5F	60	61	62	63	64	65	66	67

5. Absolute Maximum Ratings

5.1 Electrical Maximum Ratings(Ta=25deg C)

ITEM	SYMBOL	CONDITION	MIN	MAX	UNIT
Supply Voltage (Logic)	Vdd – Vss	-	0	7.0	V
Supply Voltage (LCD Drive)	Vdd – V0	-	0	11.5	V
Input Voltage	Vi	-	-0.3	Vdd +0.3	V

5.2 Environmental Conditions

ITEM	SYMBOL	CONDITION	MIN	MAX	UNIT
Operating Temp	Topr	Dry	-20	70	deg C
Storage Temp	Ttsg	Dry	-30	80	deg C

6. ELECTRICAL SPECIFICATIONS

6.1 Electrical Characteristics at Ta=25 deg C, Vdd = 5V + / - 5%

ITEM	SYMBOL	CONDITION	MIN	TYP	MAX	UNIT
Supply Voltage (logic)	Vdd-Vss	-	4.5	5	5.5	V
Supply Voltage (LCD)	Vdd-V0	Vdd = 5V	4.3	4.7	5.0	V
Input signal voltage (for E, DB0-7,R/W,RS)	V-ih	"H" level	0.7Vdd	-	Vdd	V
	V-il	"L" level	0	-	0.6	V
Supply Current (logic)	Icc	-	0.9	1	1.2	mA
Supply Current (LCD)	Io	-	0.15	0.22	0.27	mA
* Supply Voltage (LED)	V-bl	see note 1	2.9	3.1	3.3	V
*Supply Current (LED)	If	see note 1	-	80	120	mA
*Peak forward current(B/L)	Ifp	1 msec pulse 10% Duty Cycle	-	-	360	mA
*Power dissipation(B/L)	Pd		-	-	510	mW

Note 1: Backlight: Each side has 3 SMD LEDs and they are paralleled connection

*For operation above 25 °C , the If、Ifp&Pd must be derated, the current derating is -1.8mA/ °C for DC drive and -5.16mA/ °C for pulse drive,the power dissipation is -5.58 mW / °C.The Backlight working current must not more than 60% of the Ifmax or Ifpmax according to the working temperature.

6.2 Timing Specifications at $T_a = 25 \text{ deg C}$, $V_{dd} = 5V \pm 10\%$, $V_{ss} = 0V$

6.2.1 Write mode

ITEM	SYMBOL	MIN	MAX	UNIT
E cycle time	t_c	1200	-	ns
E rise time	t_R	-	25	ns
E fall time	t_F	-	25	ns
E-pulse width (H, L)	t_w	140	-	ns
R/W and RS set-up time	t_{su1}	0	-	ns
R/W and RS hold time	t_{H1}	10	-	ns
Data set-up time	t_{su2}	40	-	ns
Data hold time	t_{H2}	10	-	ns

6.2.2 Read mode

ITEM	SYMBOL	MIN	MAX	UNIT
E cycle time	t_c	1200	-	ns
E rise time	t_R	-	25	ns
E fall time	t_F	-	25	ns
E-pulse width (H, L)	t_w	140	-	ns
R/W and RS set-up time	t_{su}	0	-	ns
R/W and RS hold time	t_H	10	-	ns
Data output delay	t_D	-	120	ns
Data hold time	t_{DH}	20	-	ns

6.2.3 Timing Diagram

WRITE MODE TIMING DIAGRAM

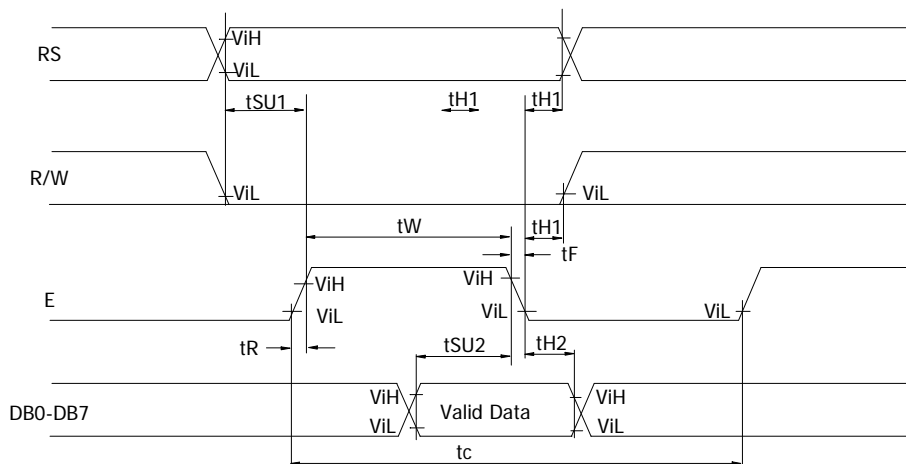

READ MODE TIMING DIAGRAM

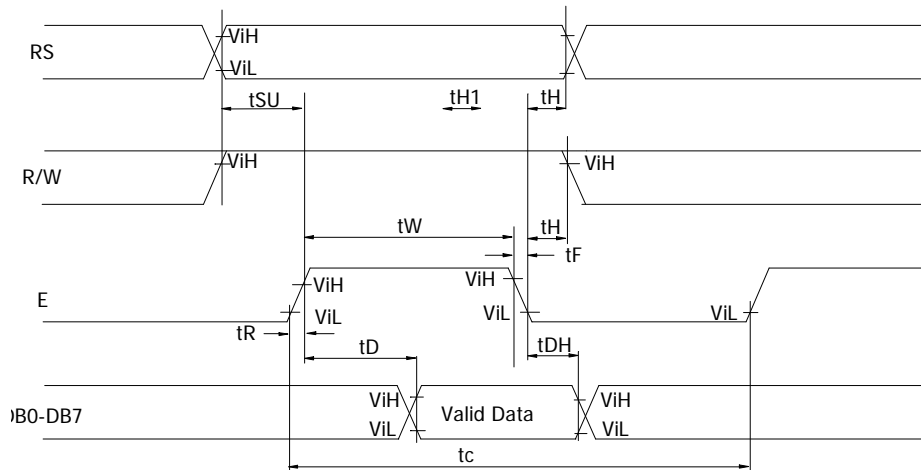

7. Example of power supplye

It is recommended to apply a potentiometer for the contrast adjust due to the tolerance of driving voltage and its temperature dependence.

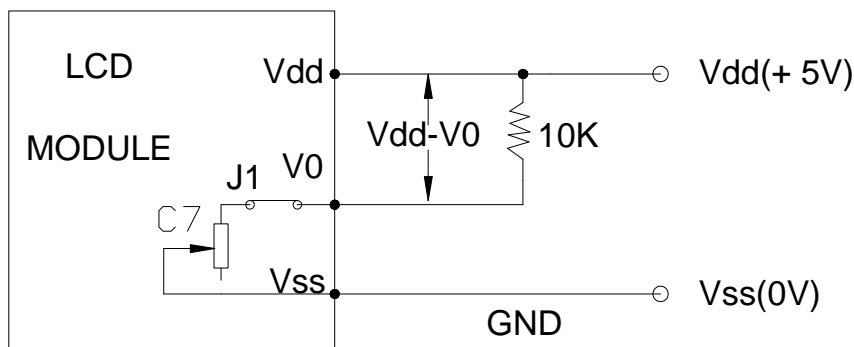

Vdd - V0: LCD Driving Voltage
 C7: 1K~10K ohm
 J1=closed

7. Electro-Optical Characteristic

ITEM	SYMBOL	CONDITION	MIN.	TYP.	MAX.	UNIT	REF.
Contrast	CR	25°C	2	12	--		Note1
Rise Time	tr	25°C	--	160	240	ms	Note2
Fall Time	tf	25°C	--	100	150	ms	note 2
Viewing Angle	$\theta 1 - \theta 2$	25°C	--	--	60	DEG	Note 3
	$\varnothing 1, \varnothing 2$		-40	--	40		
Frame Frequency	Ff	25°C	--	70	--	Hz	note 2

Note(1): Contrast ratio is defined under the following condition:

- CR= $\frac{\text{brightness of non-selected condition}}{\text{brightness of selected condition}}$
- (a). Temperature-----25C
 - (b). Frame Frequency-----64Hz
 - (c). Viewing angle----- $\theta = 0, \varnothing = 0$
 - (d). Operating Voltage---4.7V

Note(2): definition of response time:

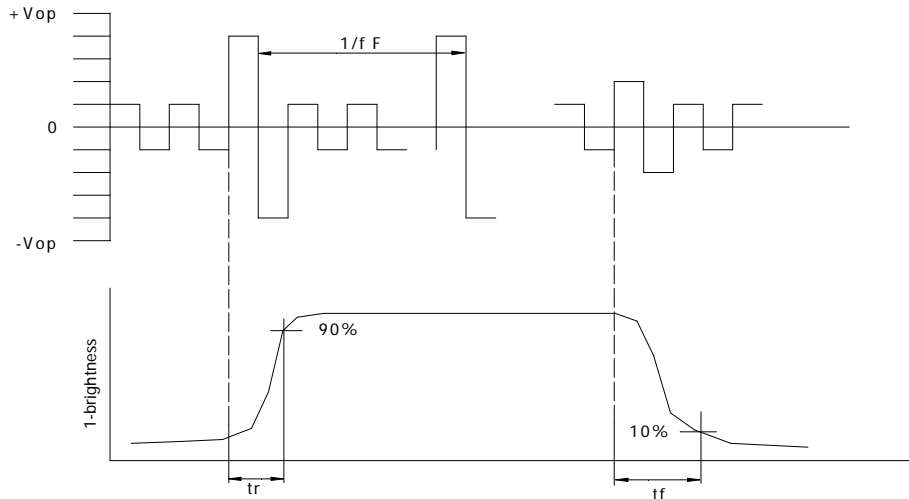

Condition:

- (a). Temperature-----25C
- (b). Frame Frequency-----64Hz
- (c). Viewing angle----- $\theta = 0, \varnothing = 0$
- (d). Operating Voltage---4.7V

Note(3): definition of view angle:

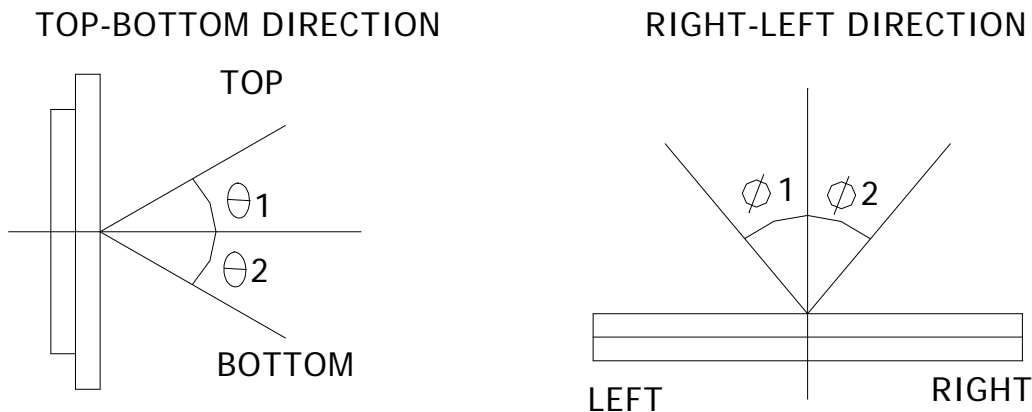

8. Instruction Table

Function	R	R	DD	DD	DD	DD	DD	DD	Description	Execu Time* (Max)		
		S	M	B	B	B	B	B				
			7	6	5	4	3	2				
								1				
Clear Display	0	0	0	0	0	0	0	0	1	Clears entire display and returns the cursor to home position (address 0)	1.64mS	
Return Home	0	0	0	0	0	0	0	0	1	X	Return the cursor to the home position. DD RAM contents remain unchanged. Set DD RAM address to zero.	1.64mS
Entry mode set	0	0	0	0	0	0	0	1	1	S	Set cursor moving direction and enable the shift of the display. These operations are performed during data write/read of DD RAM/CG RAM. 1/D=1: increment; 1/D=0: decrement; S=1: whole display shift when data is written.	40 μ S
Display ON/OFF control	0	0	0	0	0	0	1	D	C	B	Set display (D), cursor (C) and blinking of cursor (B) ON/OFF. D=1: display ON; D=0: display OFF. C=1: Cursor ON; C=0: cursor OFF. B=1: Blink ON; B=0, Blink OFF.	40 μ S
Cursor or Display shift	0	0	0	0	0	1	S	R	X	X	Move the cursor and shift the display without changing DDRAM contents. S/C=1: Display Shift; S/C=0: Cursor move. R/L=1: shift to right; R/L=0: shift to left.	40 μ S
Function Set	0	0	0	0	1	D	N	F	X	X	Set interface data length (DL), number of display lines (N) and character font (F). DL=1: 8 bits; DL=0: 4 bits. N=1: 2 lines; N=0: 1 lines. F=1: 5X11 dots; F=0: 5X7 dots.	40 μ S
Set CG RAM add	0	0	0	1						ACG	Set CG RAM address. CG RAM data is sent and received after this setting.	40 μ S
Set DD RAM Add	0	0	1							ADD	Set DD RAM address. DD RAM data is sent and received after this setting.	40 μ S
Read BF & Addr	0	1	B							AC	Read BUSY FLAG (BF) and the contents of the address counter. BF=1: internal operation; BF=0: can accept instruction.	0 μ S
Write Data to RAM	1	0								WRITE DATA	Write data into DD RAM or CG RAM.	40 μ S**
Read Data from RAM	1	0								READ DATA	Read data from DD RAM or CG RAM.	40 μ S**

10. Software Examples

8-BIT OPERATION 8 characters X 2 lines

Function	RS RW D7 D6 D5 D4 D3 D2 D1 D0	DISPLAY	DESCRIPTION
Power on delay			Initialization. No display appears.
Function set	0 0 0 0 1 1 0 0 X X		Sets 8-bit operation, 2-line display and 5*7 dots character font.
Display OFF	0 0 0 0 0 0 1 0 0 0		Turn off display.
Display ON	0 0 0 0 0 0 1 1 1 0		Turn on display and cursor.
Entry Mode set	0 0 0 0 0 0 0 1 1 0		Set mode to increment the address by one and to shift the cursor to the right, at the time of write to the DD/CG RAM. Display is not shifted.
Write data to CG/DD RAM	1 0 0 1 0 0 1 1 1 1	O	Write "O". Cursor incremented by one and shift to right.
Write data to CG/DD RAM	1 0 0 1 0 1 0 0 1 0	OR	Write "R". Cursor incremented by one and shift to right
Write data to CG/DD RAM	ORIENT	Write "I" "E" "N" "T".
Set DDRAM address	0 0 1 1 0 0 0 0 0 0	ORIENT	Set RAM address so that the cursor is positioned at the head of the Second line
Write data to CG/DD RAM	ORIENT DS	Write "D" "S".
Cursor or display shift	0 0 0 0 0 1 0 0 X X	ORIENT DS	Shift only the cursor position to the left.
Write data to CG/DD RAM	ORIENT DISPLAY	Write "I" "S" "P" "L" "A" "Y"

4-bit operation (4-bits 1 line)

Function	RS RW D7 D6 D5 D4	Display	Description
power on delay			Initialization. No display appears.
Frnction set	0 0 0 0 1 0		Sets to 4-bit operation. In this case, operation is handled as 8-bits by initialization, and Only this instruction completes with one write.
Frnction set	0 0 0 0 1 0 0 0 0 0 X X		Sets 4-bit operation, 1-line display and 5*7 dot character font. (number of display lines and character fontscannot be changed hence after.)
Display ON/OFF Control	0 0 0 0 0 0 0 0 1 1 1 0		Turn on display and cursor.
Entry Mode Set	0 0 0 0 0 0 0 0 0 1 1 0		Turn on display and cursor.
Write data to CG/DD/ARM	1 0 0 1 0 0 1 0 1 1 1 1		Write "O". Curaor incrementer by one and shift to right.
same as 8-bit operation			

11. Quality units

12.1 Purpose

This standard for quality assurance should define the quality of LCD module products to customer by EASTERNTRONIC LCD GROUP.

12.2 Scope

This document defines general provisions as well as inspection standards for LCD module supplied by EASTERNTRONIC LCD GROUP, except for those with special requirements from customer.

12.3 Definition

12.3.1 Definition of area

A Zone: Active area.

B Zone: Viewing area

C Zone: Outside viewing area.



12.3.2 Definition of size

Large size(L): 1~6 pcs LCD screens are cut out of from each 14"×16" mother glass.

Middle size(M): 7~50 pcs LCD screens are cut out of from each 14"×16" mother glass.

Small size(S): more than 50 pcs LCD screens are cut out of from each 14"×16" mother glass.

12.4 Quality Specification

12.4.1 Conditions of Cosmetic Inspection

12.4.1 Test should be conducted under the following conditions:

Ambient temperature : $22 \pm 5^{\circ}\text{C}$.

Ambient humidity: $65 \pm 20\% \text{RH}$

Ambient Luminance: 40-watt fluorescent lamp.

An appearance test should be conducted by human sight at approximately 30 cm distance

from the LCD module under fluorescent light. Distance between LCD and fluorescent lamps should be 100 cm or more. Viewing direction for inspection is 45° from vertical against LCD.

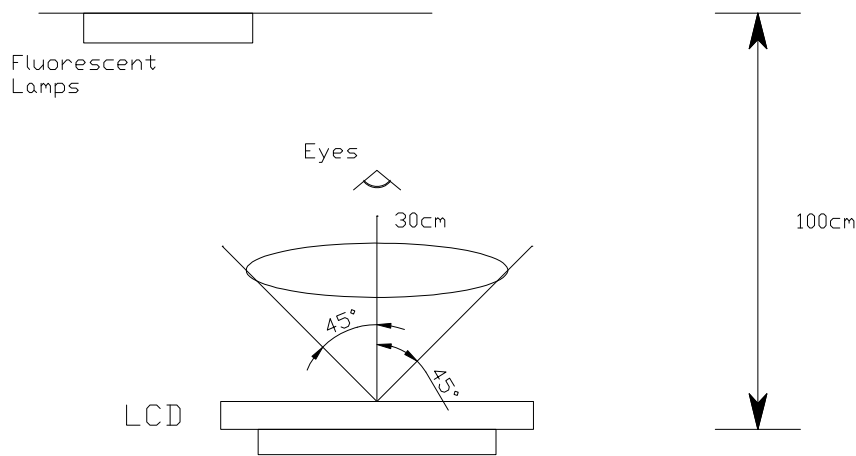

12.4.1.2 When test the model of transmissive product must add the reflective plate.

12.4.2 Sampling plan

Unless otherwise agreed in writing, the sampling inspection shall be applied to the incoming inspection of customer.

- Lot size: Quantity of shipment lot per model
- Sampling type: Normal inspection, single sampling
- Sampling Level: Level II
- Sampling table: GB/T2828.1.1(GB-national standard of China)

12.4.3 Classification of defects and Acceptable quality level

Defects and classified as either a major or minor defect defined as bellows:

- Major defect: It is a defect that is likely to result in failure or to reduce materially the usability of the product for the intended function.
- Minor defect: It is a defect that will not result in functioning problem with deviation calssific.

The AQL for major and minor defects is defined as follows:

Partition	Definition	AQL
Major defect	Functional defective as product	0.4
Minor defect	Satisfy all functions as product but not satisfy cosmetic standard	1.0

12.4.4 Applicable instrument

- LCD module tester
- Multimeter
- Caliper
- Defect size filming standard

12.4.5 Inspection quality criterion

12.4.5.1 LCD panel part

The inspection specification as following list:

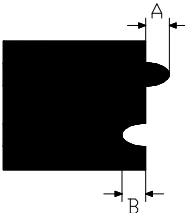
Classify	Item	Description of defects	Inspection criterion		Drawing specification
Major defect	1.Non-display	Product no function	Not accept		
	2.LCD with wrong view direction`	Difference in Spec.	Not accept		
	3.Segment missing	Part or all pattern do not light up	Not accept		
	4.Occur high current	Current exceed designed value	Not accept		
	5. LC leakage	LC does not fulfill the glass cell	Not accept		
	6.Deviation from drawing	LCM Dimension difference from drawing and over tolerance	According to dimensions noted in the specification		
	7.Wrong type applied	Wrong polarizer attachment	Not accept		
		Pin attached wrong type applied	Not accept		
8.Incorrect pins quality	Pin attached wrong quantity applied	Not accept			
Minor defect	9.Pattern deformation	Segment fatter or smaller	Dimension (mm)	Acceptable number	
			$A \leq 0.1$	Not count (Should not be connected to next dot)	

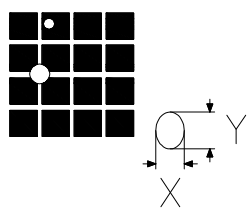
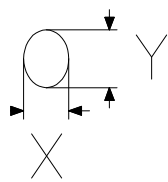
			0.10<A≤0.15	1 pc / dot(only segment)or less 2 pcs / cell or less (Should not be connected to next dot)																	
			B ≤ 0.10	Not count																	
Minor defect	10.Pinholes	Black spot/white spot at activated state	<p>1. large size LCD Accept if can't be found at 1m distance and will not enlarge under electronic test</p> <p>2. Middle size LCD Diameter(mm) Accept QTY</p> <table border="0"> <tr> <td>$\Phi \leq 0.15$</td> <td>Not count</td> </tr> <tr> <td>$0.15 < \Phi \leq 0.25$</td> <td>3</td> </tr> <tr> <td>$0.25 < \Phi \leq 0.35$</td> <td>1</td> </tr> <tr> <td>$\Phi > 0.35$</td> <td>0</td> </tr> </table> <p>3. Small size LCD Diameter(mm) Accept QTY</p> <table border="0"> <tr> <td>$\Phi \leq 0.15$</td> <td>Not count</td> </tr> <tr> <td>$0.15 < \Phi \leq 0.25$</td> <td>2</td> </tr> <tr> <td>$0.25 < \Phi \leq 0.30$</td> <td>1</td> </tr> <tr> <td>$\Phi > 0.30$</td> <td>0</td> </tr> </table> <p>4. For the dot pattern: accept if the area of defect is less than or equal to half of one lattice's</p> <p>5. Only allow one defect in one segment</p> <p>6. The nearest distance allowed between two pinholes is 20mm</p>		$\Phi \leq 0.15$	Not count	$0.15 < \Phi \leq 0.25$	3	$0.25 < \Phi \leq 0.35$	1	$\Phi > 0.35$	0	$\Phi \leq 0.15$	Not count	$0.15 < \Phi \leq 0.25$	2	$0.25 < \Phi \leq 0.30$	1	$\Phi > 0.30$	0	 <p>$\Phi = (X+Y)/2$</p>
	$\Phi \leq 0.15$	Not count																			
$0.15 < \Phi \leq 0.25$	3																				
$0.25 < \Phi \leq 0.35$	1																				
$\Phi > 0.35$	0																				
$\Phi \leq 0.15$	Not count																				
$0.15 < \Phi \leq 0.25$	2																				
$0.25 < \Phi \leq 0.30$	1																				
$\Phi > 0.30$	0																				
	11.Blemishes and foreign matters	Black spot/dust on LCD(non-display)	<p>Positive panel:</p> <p>1.A zone - Large size LCD Accept if can't find at 1m distance and will not enlarge under electronic test:</p>		 <p>$\Phi = (X+Y)/2$</p>																

			<p>-Middle size LCD Diameter(mm) Accept QTY</p> <table> <tr> <td>$\Phi \leq 0.15$</td> <td>Not count</td> </tr> <tr> <td>$0.15 < \Phi \leq 0.25$</td> <td>3</td> </tr> <tr> <td>$0.25 < \Phi \leq 0.35$</td> <td>1</td> </tr> <tr> <td>$\Phi > 0.35$</td> <td>0</td> </tr> </table> <p>-Small size LCD Diameter(mm) Accept QTY</p> <table> <tr> <td>$\Phi \leq 0.15$</td> <td>Not count</td> </tr> <tr> <td>$0.15 < \Phi \leq 0.25$</td> <td>2</td> </tr> <tr> <td>$0.25 < \Phi \leq 0.30$</td> <td>1</td> </tr> <tr> <td>$\Phi > 0.30$</td> <td>0</td> </tr> </table> <p>2.B zone 1.5 times of acceptable largest diameter size of Zone A</p> <p>3.C zone Notcount.</p> <p>Negative panel:</p> <p>1. A zone -Large size LCD Diameter(mm) Accept QTY</p> <table> <tr> <td>$\Phi \leq 0.15$</td> <td>Not count</td> </tr> <tr> <td>$0.15 < \Phi \leq 0.30$</td> <td>4</td> </tr> <tr> <td>$0.30 < \Phi \leq 0.50$</td> <td>1</td> </tr> <tr> <td>$\Phi > 0.50$</td> <td>0</td> </tr> </table> <p>-Middle&small size LCD Diameter(mm) Accept QTY</p> <table> <tr> <td>$\Phi \leq 0.15$</td> <td>Not count</td> </tr> <tr> <td>$0.15 < \Phi \leq 0.25$</td> <td>3</td> </tr> <tr> <td>$\Phi > 0.25$</td> <td>0</td> </tr> </table> <p>2. B zone 1.5 times of acceptable largest diameter size of Zone A</p> <p>3.C zone No count The nearest diatance allowed between two black spot is 20mm</p>	$\Phi \leq 0.15$	Not count	$0.15 < \Phi \leq 0.25$	3	$0.25 < \Phi \leq 0.35$	1	$\Phi > 0.35$	0	$\Phi \leq 0.15$	Not count	$0.15 < \Phi \leq 0.25$	2	$0.25 < \Phi \leq 0.30$	1	$\Phi > 0.30$	0	$\Phi \leq 0.15$	Not count	$0.15 < \Phi \leq 0.30$	4	$0.30 < \Phi \leq 0.50$	1	$\Phi > 0.50$	0	$\Phi \leq 0.15$	Not count	$0.15 < \Phi \leq 0.25$	3	$\Phi > 0.25$	0	
$\Phi \leq 0.15$	Not count																																	
$0.15 < \Phi \leq 0.25$	3																																	
$0.25 < \Phi \leq 0.35$	1																																	
$\Phi > 0.35$	0																																	
$\Phi \leq 0.15$	Not count																																	
$0.15 < \Phi \leq 0.25$	2																																	
$0.25 < \Phi \leq 0.30$	1																																	
$\Phi > 0.30$	0																																	
$\Phi \leq 0.15$	Not count																																	
$0.15 < \Phi \leq 0.30$	4																																	
$0.30 < \Phi \leq 0.50$	1																																	
$\Phi > 0.50$	0																																	
$\Phi \leq 0.15$	Not count																																	
$0.15 < \Phi \leq 0.25$	3																																	
$\Phi > 0.25$	0																																	

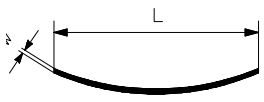
	12.Black lines and scratches	Scratch on glass or polarizer surface.And foreign linear matters in LCD	<p>Positive panel:</p> <p>1.A zone</p> <p>- Large size LCD Accept if can't find at 1m distance and will not enlarge under electronic test.</p> <p>-Middle size LCD Diameter(mm) Accept QTY $W \leq 0.02$ Not count $0.02 < W \leq 0.03, L \leq 4$ 2 $0.03 < W \leq 0.05, L \leq 3$ 2 $0.02 < W \leq 0.03, L > 4$ 0 $0.03 < W \leq 0.05, L > 3$ 0 $W > 0.05$ As the spot criteria.</p> <p>-Small size LCD Diameter(mm) Accept QTY $W \leq 0.02$ Not count $0.02 < W \leq 0.03, L \leq 4$ 2 $0.03 < W \leq 0.05, L \leq 2$ 1 $0.02 < W \leq 0.03, L > 4$ 0 $0.03 < W \leq 0.05, L > 2$ 0 $W > 0.05$ As the spot criteria.</p> <p>2.B zone 1.5 times of acceptable largest diameter size of Zone A</p> <p>3.C zone Notcount.</p> <p>Negative panel:</p> <p>1. A zone</p> <p>-Large size LCD Diameter(mm) Accept QTY $W \leq 0.02$ Not count $0.02 < W \leq 0.03, L \leq 5$ 3 $0.03 < W \leq 0.05, L \leq 4$ 2 $0.02 < W \leq 0.03, L > 5$ 0 $0.03 < W \leq 0.05, L > 4$ 0 $W > 0.05$ As the spot criteria.</p> <p>-Middle size LCD</p>	
--	------------------------------	---	--	---

			<p>Diameter(mm) Accept QTY $W \leq 0.02$ Not count $0.02 < W \leq 0.03, L \leq 4$ 2 $0.03 < W \leq 0.05, L \leq 2$ 2 $0.02 < W \leq 0.03, L > 3$ 0 $0.03 < W \leq 0.05, L > 2$ 0 $W > 0.05$ As the spot criteria. - Small size LCD Diameter(mm) Accept QTY $W \leq 0.02$ Not count $0.02 < W \leq 0.03, L \leq 3$ 2 $0.03 < W \leq 0.05, L \leq 3$ 1 $0.02 < W \leq 0.03, L > 3$ 0 $0.03 < W \leq 0.05, L > 2$ 0 $W > 0.05$ As the spot criteria.</p> <p>2. B zone 1.5 times of acceptable largest diameter size of Zone A</p> <p>3. C zone Not count The nearest distance allowed between two defects is 20mm</p>	
Mintor defect	13. Scratch on PI coating	PI coating scratched	The visible scratch of A zone can not be accepted at 30cm view distance.	
Mintor defect	14. Rainbow	Arches, circular or parallel colorful spread	According to the limit specimen	
Mintor defect	15. Bubbles or wrinkles in polarizer	Bubbles or wrinkles between polarizer and glass	A zone: The visible defect can not be accepted at 30cm view distance. B zone: Not count	
Mintor defect	16. Position of polarizer attachment	Wrong polarizer attachment in position or dimension	Polarizer protruding from edge of glass and exceeding/within the maximum external dimension of LCD	

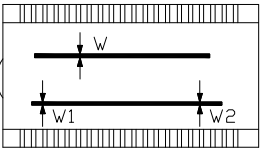
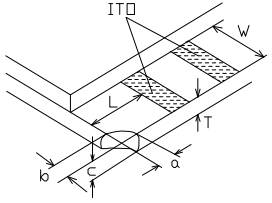
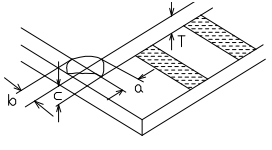
Mintor defect	17. Ink printing defect	17.1 Ink line/pattern broken	Not accept				
		17.2 Ink pattern/line jagged	Accept if the thick or thin part is less than equal to 25% segment width, or according to the limit specimen				
		17.3 Light leakage	When activated with current white light appears in the position of pinhole or scratch due to ink printing misalignment. According to the pinhole specification.				
		17.4 Ink printing pattern/line uneven	Reject if the thick or thin in more than 1/2W. Reject when $W1-W2 \leq 1/3W$				
Mintor defect	18. Pin defect	18.1 Corrosion or foreign material on terminal legs	Pin incoming defect: oxidized, damage (including pins plating damaged), excess epoxy on bottom glass or terminal legs. Not accept.				
		18.2 Pin deviation over tolerance	According to the specification				
Mintor defect	19. Chipped glass on comer	19.1 Chip in lead contact area.	a	b	c	accept QTY	
			$a \leq 5\text{mm}$ $L > 5\text{mm}$ m	$b \leq W$	$c \leq T$	3	
			$a < L$ $L < 5\text{mm}$ m	$b \leq W$	$c \leq T$	3	
		19.2 Others	Not exceed 1/2 width of seal		$c \leq T$	3	

Mintor defect	20. Glass chip on edge		a	b	c	accept QTY	
			$a \leq 5\text{mm}$	Not exceed 1/2 width of seal	$c \leq T$	3	
Mintor defect	21. Clipped electrode pad	21.1 Glass chip on ITO edge	a	b	c	accept QTY	
			$a \leq 4\text{mm}$ (and not exceed 4 ITO terminal)	$b \leq W/4$	$c \leq T$	3	
		21.2 Glass chip on ITO back	a	b	c	accept QTY	
			$a \leq 5\text{mm}$	$b \leq W/3$	$c \leq T$	3	
Mintor defect	22. Mechanical damage	Extended crack inspector shall attempt to remove the chip with tweezers, re-evaluate if the remaining defect is still a crack or a chip	b		accept QTY		
			$b \leq W/4$		2		
Mintor defect	23. Glass cracks		Not accept				

Remark:

The minimum space between any 2 defects (spot, dirt) should be more than 20mm, and max. allowed defect QTY in total:

Large size LCD: Zone A ≤ 5 /unit, Zone B ≤ 5 /unit;

Middle size LCD: Zone A ≤ 3 /unit, Zone B ≤ 3 /unit;

Small size LCD: Zone A ≤ 2 /unit, Zone B ≤ 2 /unit;

12.4.5.2 Other part

The inspection specification as following list:

NO.	Items	Criterion of defects	AQL
1	Backlight	1. Lumination source flickers. 2. Using spot, lines and contamination standard of LCD to judge the spots or scratches defect on backlight. 3. Not allow unlighted on backlight. 4. Colour and luminance of backlight should correspond its specification.	Major Minor Major Major
2	PCB,COB	1.COB seal may not have pinholes larger than0.2mm or contamination. 2.COB seal surface may not have pinholes through to the IC. 3. The height of COB should not exceed the height indicated in the assembly diagram. 4. Beyond 2mm of the seal area, there may not have sealant on the PCB. 5.No oxidation or contamination on PCB connector. 6.Parts on PCB should correspond the characteristic,and not allow wrong parts,missing parts or additional parts. 7.The jumper on the PCB should correspond to the characteristic. 8.The solder which gets on bezel,LED pad,zebra pad or screw hole pad should be smoothed down.	Minor Minor Major Minor Minor Major Minor Major
3	Soldering	1. No unmelted solder pastes on the PCB. 2. No cold solder joints,solder connection missing,oxidation of solder. 3. No short circuits in components on PCB.	Minor Minor Minor
4	General Appearance	1. No oxidation, contamination, curves,cracks or bends on interface Pin of TCP. 2. No solder residue or solder balls on product. 3. The IC on TCP may not be damaged. 4. The residual rosin or tin oil of soldering(component or chip component) is not turned into brown or black colour. 5. Packing method correspond the specification. 6. Dimension and structure correspond the specification sheet. 7. No dirt and break on the heat seal.	Minor Minor Major Minor Major Major Major

12.5 Reliability

The LCD module shall not fail the following reliability test.

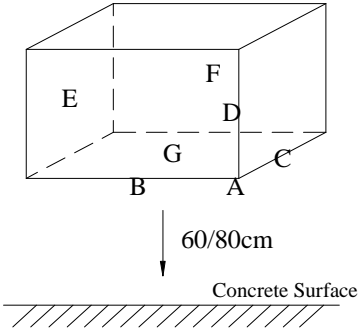
Item	Condition	Criterion	
High temperature operation	+70°C ± 2°C, 8 hours	1.Total current consumption should be below double of initial value. 2.Cosmetic defects should not be happened	
Low temperature operation	-20°C ± 2°C, 8 hours		
Humidity	Operation		40 °C ± 2 °C ,93% ± 2%RH,8 hours
	Storage		40 °C ± 2 °C ,93% ± 2%RH, 24 hours
High temperature storage	+80°C ± 2°C, 10 hours		
Low temperature storage	-30°C ± 2°C, 10 hours		
Thermal shock storage	-20°C ~ +70°C 60min~60min, 5 cycles		
Vibration test	Amplitude:0.7~1.0mm,frequency:50Hz,30min in each direction(X,Y,Z)		
Shock test	To be measured after dropping from 60cm or 80cm high on the concrete surface in packing state.(weight ≥ 15Kg,dropping height 60cm; Weight < 15Kg,dropping height 80cm) <div style="text-align: center;">  </div> <div style="margin-left: 20px;"> <p>Dropping method</p> <p>corner dropping A corner: once</p> <p>Edge dropping B,C,D edge: once</p> <p>Face dropping E,F,G face: once</p> </div>		
Remark: The function test shall be conducted after 4 hours storage at the normal temperature and humidity after removed from the test chamber.			

12. Precaution For Using LCM

1. LIQUID CRYSTAL DISPLAY (LCD)

LCD is made up of glass, organic sealant, organic fluid, and polymer based polarizers. The following precautions should be taken when handling,

- (1). Keep the temperature within range of use and storage. Excessive temperature and humidity could cause polarization degradation, polarizer peel off or bubble.
- (2). Do not contact the exposed polarizers with anything harder than an HB pencil lead. To clean dust off the display surface. Wipe gently with cotton. Chamois or other soft material soaked in petroleum benzine.
- (3). Wipe off saliva or water drops immediately. Contact with water over a long period of time may cause polarizer deformation or color fading, while an active LCD with water condensation on its surface will cause corrosion of ITO electrodes.
- (4). Glass can be easily chipped or cracked from rough handling, especially at corners and edges.
- (5). Do not drive LCD with DC voltage.

2. Liquid Crystal Display Modules

2.1 Mechanical Considerations

LCM are assembled and adjusted with a high degree of precision. Avoid excessive shocks and do not make any alterations or modifications. The following should be noted.

- (1). Do not tamper in any way with the tabs on the tabs on the metal frame.
- (2). Do not modify the PCB by drilling extra holes, changing its outline, moving its components or modifying its pattern.
- (3). Do not touch the elastomer connector, especially insert an backlight panel (for example, EL).
- (4). When mounting a LCM make sure that the PCB is not under any stress such as bending or twisting. Elastomer contacts are very delicate and missing pixels could result from slight dislocation of any of the elements.
- (5). Avoid pressing on the metal bezel, otherwise the elastomer connector could be deformed and lose contact, resulting in missing pixels.

2.2. Static Electricity

LCM contains CMOS LSI's and the same precaution for such devices should apply, namely

- (1). The operator should be grounded whenever he/she comes into contact with the module. Never touch any of the conductive parts such as the LSI pads, the copper leads on the PCB and the interface terminals with any parts of the human body.

- (2). The modules should be kept in antistatic bags or other containers resistant to static for storage.

- (3). Only properly grounded soldering irons should be used.

- (4). If an electric screwdriver is used, it should be well grounded and shielded from commutator sparks.

- (5). The normal static prevention measures should be observed for work clothes and working benches; for the latter conductive (rubber) mat is recommended.

- (6). Since dry air is inductive to statics, a relative humidity of 50-60% is recommended.

2.3. Soldering

- (1). Solder only to the I/O terminals.

- (2). Use only soldering irons with proper grounding and no leakage.

- (3). Soldering temperature: $280\text{ }^{\circ}\text{C} \pm 10^{\circ}\text{C}$

- (4). Soldering time: 3 to 4 sec.

- (5). Use eutectic solder with resin flux fill.

- (6). If flux is used, the LCD surface should be covered to avoid flux spatters. Flux residue should be removed afterwards.

2.4. Operation

- (1). The viewing angle can be adjusted by varying the LCD driving voltage V_0 .

- (2). Driving voltage should be kept within specified range; excess voltage shortens display life.

- (3). Response time increases with decrease in temperature.

- (4). Display may turn black or dark blue at temperatures above its operational range; this is (however not pressing on the viewing area) may cause the segments to appear "fractured".

- (5). Mechanical disturbance during operation (such as pressing on the viewing area) may cause the segments to appear "fractured".

2.5. Storage

If any fluid leaks out of a damaged glass cell, wash off any human part that comes into contact with soap and water. Never swallow the fluid. The toxicity is extremely low but caution should be exercised at all the time.

2.6. Limited Warranty

Unless otherwise agreed between EASTERNTRONIC and customer, EASTERNTRONIC will replace or repair any of its LCD and LC, which is found to be defective electrically and visually when inspected in accordance with EASTERNTRONIC acceptance standards, for a period on one year from date of shipment. Confirmation of such date shall be based on freight documents. The warranty liability of EASTERNTRONIC is limited to repair and/or replacement on the terms set forth above. EASTERNTRONIC will not be responsible for any subsequent or consequential events.



13. Declaration of conformity regarding the limitation of dangerous substances

深圳易事通液晶显示模块有限公司

SHENZHEN EASTERNTRONIC LCM CO., LTD.

4F, B3 Building, FuYuan Industrial Zone, FuYong Town,

BaoAn District, ShenZhen, P.R.China

DECLARATION OF CONFORMITY REGARDING THE LIMITATION OF DANGEROUS SUBSTANCES
--

WE, SHENZHEN EASTERNTRONIC LCM CO., LTD,

Declare that the product of CS2004C-D-YSXFSWN-100 complies with: The directive 2002/95/EC Dated 2003/01/27 regarding the limitation of dangerous substances, in particular to clause 4 which forbids the use of the following elements:

- Lead
- Mercury
- Cadmium
- Hexavalent chromium
- Polybrominated biphenyls
- Polybrominated diphenylethers

And to the annex which points out the exempted implementations

To the directive 73/23/EEC dated 1973/02/19 and the standard EN60335-1 regarding prohibition of following elements:

- Oils containing polychlorinated biphenyl
- Asbestos
- Radioactive substances

SHENZHEN EASTERNTRONIC LCM CO., LTD.

Issued on May 24, 2011

According with the proposal of Technical Adaption Committee (TAC) of a limit of 0.1% by weight for lead hexavalent chromium, mercury, PBBs and PBDRs and 0.01% by weight for Cadmium.