



DATA IMAGE CORPORATION

LCD Module Specification

ITEM NO.: CM160224SFAYBG09

Table of Contents

- 1. COVER & CONTENTS 1
- 2. RECORD OF REVISION 2
- 3. GENERAL SPECIFICATIONS 3
- 4. ABSOLUTE MAXIMUM RATINGS 4
- 5. ELECTRICAL CHARACTERISTICS 6
- 6. ELECTRO-OPTICAL CHARACTERISTIC 6
- 7. TIMING CHARACTERISTICS 9
- 8. PIN CONNECTIONS 11
- 9. POWER SUPPLY 11
- 10. BLOCK DIAGRAM 12
- 11. QUALITY ASSURANCE 19
- 12. LCM PRODUCT LABEL DEFINE 23
- 13. PRECAUTIONS IN USE LCM 25
- 14. OUTLINE DRAWING 26
- 15. PACKAGE INFORMATION..... 27

Customer Companies	R&D Dept.	Q.C. Dept.	Eng. Dept.	Prod. Dept.
	<i>Jack</i>	<i>Eric</i>	<i>Ken</i>	<i>Huang</i>
Approved by	Version:	Issued Date:	Sheet Code:	Total Pages:
	C	23/AUG/10'		27

2. RECORD OF REVISION

Rev	Date	Item	Page	Comment
A	2005/8/30			New Release.
B	2006/11/16	5,6	6	Modify LCD Data.
C	23/AUG/10'	6 11 12 14	6 19 23 26	1.Modify: ELECTRO-OPTICAL CHARACTERISTIC 2.Add test time 96H at test condition 1~4 3.Revise LCM PRODUCT LABEL DEFINE 4.Revise OUTLINE DRAWING from CM160224 rev.A to CM160224A-02 rev.A

3. GENERAL SPECIFICATION

Display Format : 16characters (W) × 2lines (H)
 Character Size : 2.95 (W) × 5.55 (H) mm
 View Area : 62.2 (W) × 17.9 (H) mm
 General Dimensions : 84 (W) × 44 (H) × 14.5 (T) mm Max.

Weight : 36 g max.

LCD Type & Background Color: STN Blue Gray STN Yellow Green FSTN

Polarizer mode : Reflective Transflective

Transmissive Negative

View Angle : 6 O'clock 12 O'clock Others _____

Backlight : LED EL CCFL

Backlight Color : Yellow green Amber Blue Green

White Others

Controller : ST7066U-0A

Temperature Range : Normal Wide Temperature
 Operating 0 to 50°C Operating -20 to 70°C
 Storage -20 to 70°C Storage -30 to 80°C

Pixel Color: Blue

REMARK:

Our components and processes are compliant to RoHS standard.

4. ABSOLUTE MAXIMUM RATINGS

4.1 ELECTRICAL ABSOLUTE MAXIMUM RATINGS

 $V_{SS}=0V, T_a = 25^{\circ}C$

Item	Symbol	Min.	Max.	Unit
Supply Voltage (Logic)	VDD-VSS	-0.3	7	V
Supply Voltage (LCD Driver)	VDD -VO	-0.3	10.0	V
Input Voltage	VI	-0.3	VDD+0.3	V
Operating Temperature	TOP	-20	70	°C
Storage Temperature	TSTG	-30	80	°C

4.2 ENVIRONMENTAL ABSOLUTE MAXIMUM RATINGS

Item	Operating		Storage		Comment
	(Min.)	(Max.)	(Min.)	(Max.)	
Ambient Temp	-20	70	-30	80	Note (1)
Humidity	Note (2)		Note(2)		Without Condensation
Vibration	--	4.9M/S ²	--	19.6M/S ²	XYZ Direction
Shock	--	29.4M/S ²	--	490M/S ²	XYZ Direction

Note(1) $T_a = 0^{\circ}C$: 50Hr Max.

Note(2) $T_a \leq 40^{\circ}C$: 90% RH Max.

$T_a \geq 40^{\circ}C$: Absolute humidity must be lower than the humidity of 90% RH at 40°C.

4. 3 Electronic Static Discharge maximum rating

ESD test method : IEC 61000-4-2

Item	Description	
Testing environment	Ambient temperature :15°C to 35 °C Humidity: 30% to 60 % LCM (E.U.T) : Power up	
Testing equipment	Manufacture: Noise Ken, Model No. ESD-100L	
Testing condition	See drawing 1	
Direct discharge	0 to ± 6 KV	Discharge point, see drawing 2
Indirect discharge	0 to ± 12KV	Discharge point, see drawing 1
Pass condition	No malfunction of unit. Temporary malfunction of unit which can be recovered by system reset	
Fail condition	Non. Recoverable malfunction of LCM or system	

FIG 1 ESD TESTING EQUIPMENT

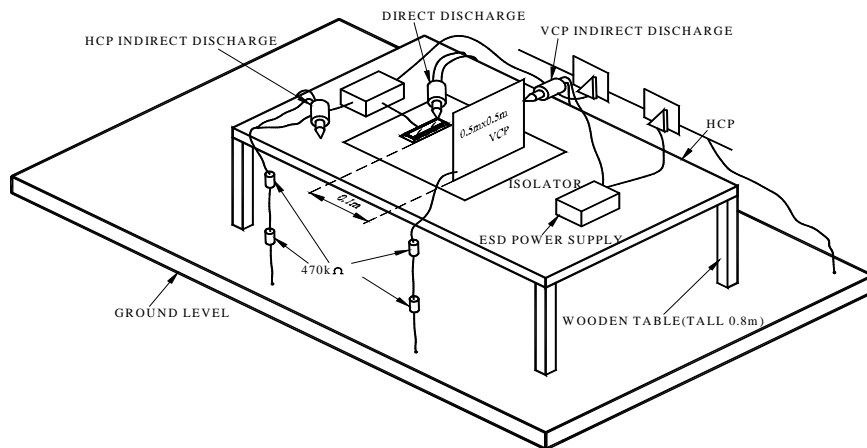

(1)

DIRECT CONTACT DISCHARGE

CONTACT POINT : A.B.C.D

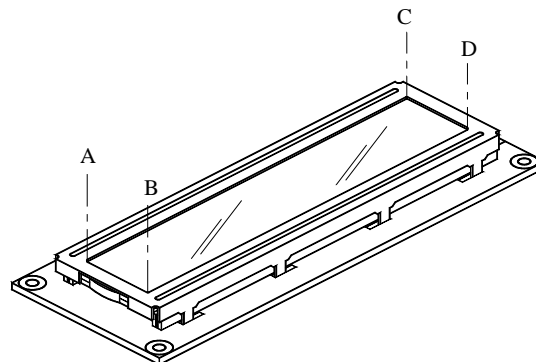

(2)

5. ELECTRICAL CHARACTERISTICS

Item	Symbol	Condition	Min.	Typ.	Max.	Unit
Supply Voltage (Logic)	VDD-VSS		2.7	5.0	5.5	V
Supply Voltage (LCD)	VDD-VO	-20°C	4.3	4.4	4.7	V
		25°C	3.9	4.1	4.2	
		70°C	3.6	3.8	4.0	
Input Voltage	V _{IH}	--	0.7*VDD	--	VDD	V
	V _{IL}		-0.3	--	0.6	
Logic Supply Current	I _{DD}	VDD-VSS=5V	--	1.1	--	mA

6. ELECTRO-OPTICAL CHARACTERISTICS

ITEM	Symbol	Condition	Min.	Typ.	Max.	Unit	Ref.
Rise Time	Tr	-20°C	--	--	10000	ms	Note (1)
		25°C		100	250		
Fall Time	Tf	-20°C	--	--	10000	ms	
		25°C		150	250		
Contrast	CR	25°C		8			Note (3)
View Angle	θ ₁ ~θ ₂	25°C & CR≥3	-45		50	deg	Note (2)
	∅ ₁ , ∅ ₂		-44		44		
Frame Frequency	Ff	25°C		64		Hz	

Note (1) & (2) : See next page

Note (3) : Contrast ratio is defined under the following condition:

$$CR = \frac{\text{Brightness of non-selected condition}}{\text{Brightness of selected condition}}$$

- (a). Temperature ----- 25°C
- (b). Frame frequency ---- 64Hz
- (c). Viewing angle ----- θ= 0°, ∅ = 0°
- (d). Operating voltage --- 4.1V

Note (1) Response time is measured as the shortest period of time possible between the change in state of an LCD segment as demonstrated below:

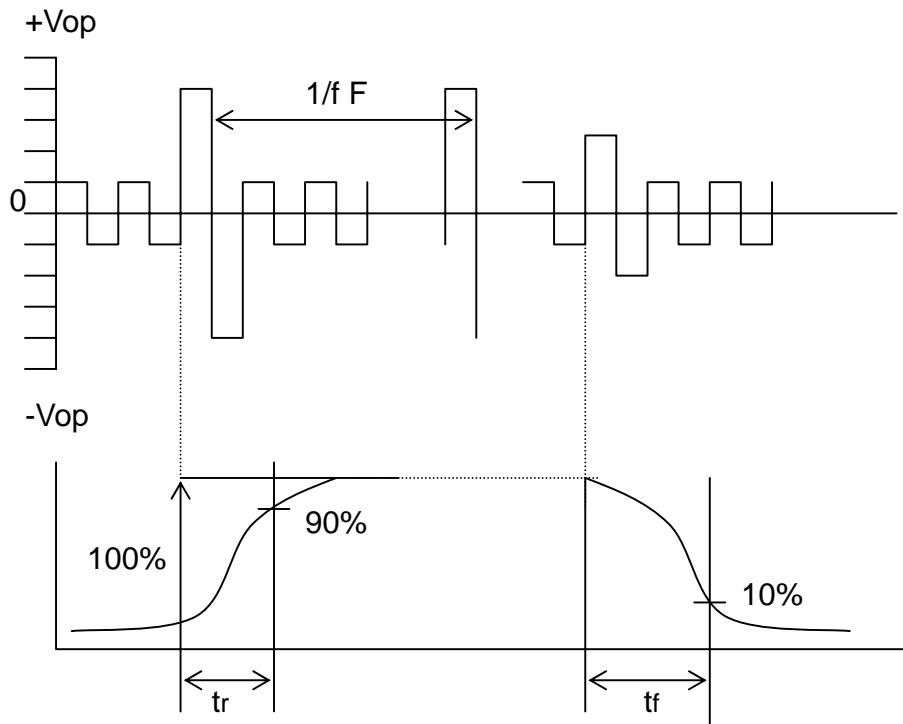

Condition:

- (a) . Temperature -----25°C
- (b) . Frame frequency ----- 64Hz
- (c) . View Angle ----- $\theta = 0^\circ, \varnothing = 0^\circ$
- (d) . Operating voltage ----- 4.1V

Note (2) Definition of View Angle

Top – Bottom direction

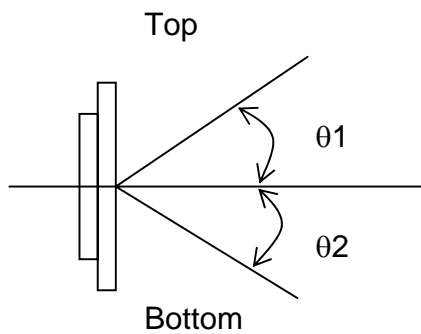

Right -- Left direction

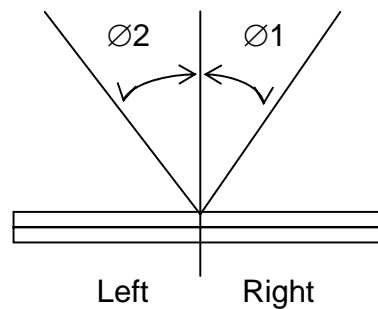

6.1 LED ELECTRO-OPTICAL CHARACTERISTIC

Ta = 25°C

Item	Symbol	Condition	Min.	Typ.	Max.	Unit
Forward Voltage	V _F	I _F = 120mA Yellow Green	--	4.1	4.2	V
Luminous Intensity	I _V	I _F = 120mA Yellow Green	55	90	--	cd/m ²
Peak Emission	λ _P	I _F = 120mA Yellow Green	--	573	--	nm
Spectrum Radiation	Δλ	I _F = 120mA Yellow Green	--	30	--	nm
Reverse Current	I _R	V _R = 8V Yellow Green	--	--	0.2	mA

Note : Measured at the bared LED backlight unit.

6.2 LED MAXIMUM OPERATING RANGE

Item	Symbol	Yellow Green	Unit
Power Dissipation	P _{AD}	0.76	W
Forward Current	I _{AF}	180	mA
Reverse Voltage	V _R	8	V

6.2.1 LED ARRAY BLOCK DIAGRAM

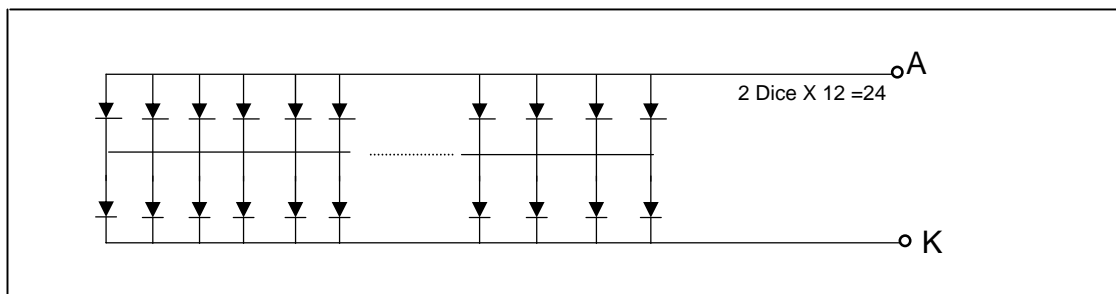

6.2.2 LED POWER SOURCE

	Power source	Jumper setting	Mark
LED	VDD/VSS	J1,J3,R9	
	15K/16A	J2,J5,J7	V
	A/K	NONE	
	15A/16K	J2,J4,J6	
GND	FRM GND	J9	

7. TIMING CHARACTERISTICS

7.1 WRITE TIMING

AC characteristics (VDD=5V, Ta=25°C)

Item	Symbol	Condition	Min.	Max.	Unit
E cycle time	tc	VDD = 5V	1200	--	ns
E pulse width	tPW		140	--	
E rise/fall time	tR, tF		--	25	
RS and RW, E Address Setup time	tAS		0	--	
RW and RS, E Address Hold time	tAH		10	--	
Data setup time	tDSW		40	--	
Data hold time	tH		10	--	

AC characteristics (VDD=2.7V, Ta=25°C)

Item	Symbol	Condition	Min.	Max.	Unit
E cycle time	tc	VDD = 2.7V	1200	--	ns
E pulse width	tPW		460	--	
E rise/fall time	tR, tF		--	25	
RS and RW, E Address Setup time	tAS		0	--	
RW and RS, E Address Hold time	tAH		10	--	
Data setup time	tDSW		80	--	
Data hold time	tH		10	--	

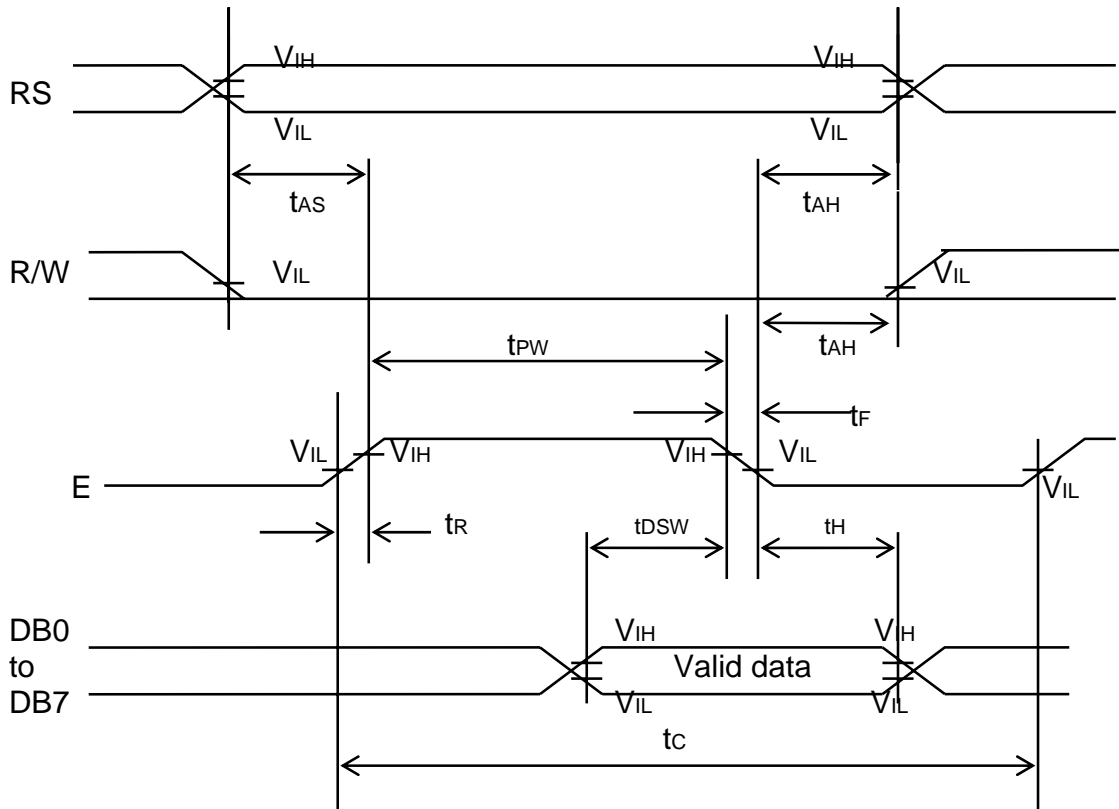

7.2 READ TIMING

AC characteristics (VDD=5V, Ta=25°C)

Item	Symbol	Condition	Min.	Max.	Unit
E cycle time	t _c	VDD = 5V	1200	--	ns
E pulse width	t _{PW}		140	--	
E rise/fall time	t _R , t _F		--	25	
RS and RW, E Address Setup time	t _{AS}		0	--	
RS and RW, E Address Hold time	t _{AH}		10	--	
Data Setup time	t _{DDR}		--	100	
Data hold time	t _H		10	--	

AC characteristics (VDD=2.7V, Ta=25°C)

Item	Symbol	Condition	Min.	Max.	Unit
E cycle time	t _c	VDD = 2.7V	1200	--	ns
E pulse width (high level)	t _{PW}		480	--	
E rise/fall time	t _R , t _F		--	25	
RW and RS, E Address setup time	t _{AS}		0	--	
RW and RS, E Address Hold time	t _{AH}		10	--	
Data output delay time	t _{DDR}		--	320	
Data hold time	t _H		10	--	

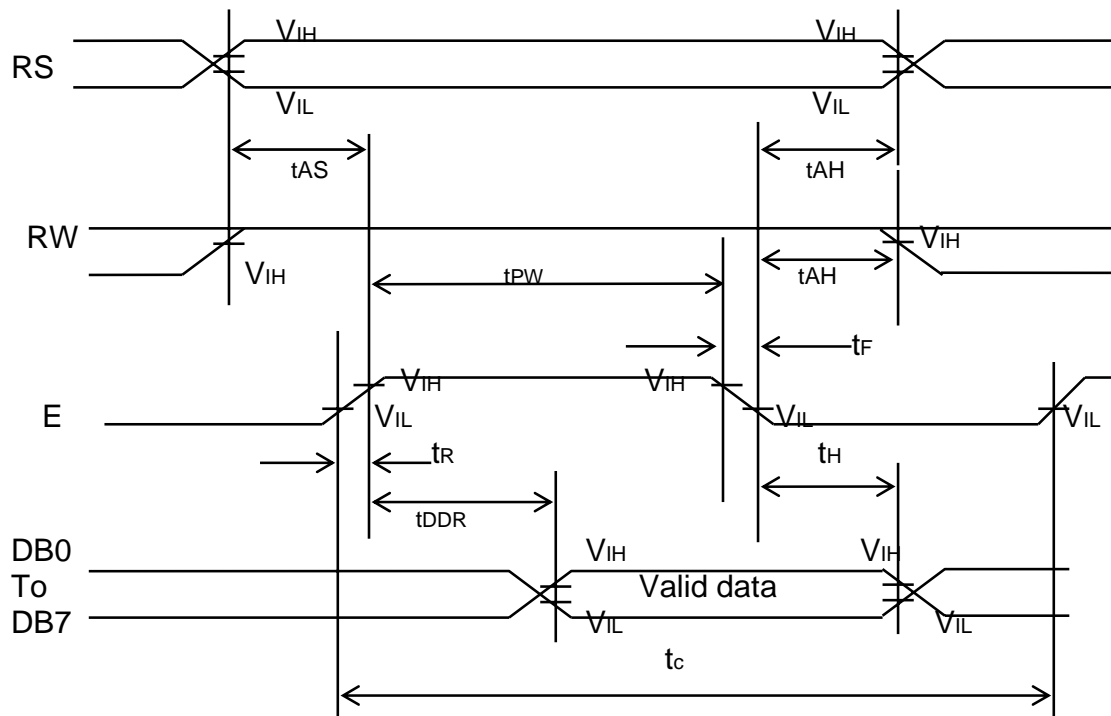

8. PIN CONNECTIONS

No.	Symbol	Function
1	VSS	Ground, 0V
2	VDD	Logic power supply, +5V
3	VO	Voltage for LCD drive
4	RS	Data / Instruction register select
5	R/W	Read / Write
6	E	Enable signal, start data read/write
7	DB0	Data Bus Line
8	DB1	
9	DB2	
10	DB3	
11	DB4	
12	DB5	
13	DB6	
14	DB7	
15	LEDK	LED Cathode, ground 0V
16	LEDA	LED Anode, power supply +

9. POWER SUPPLY

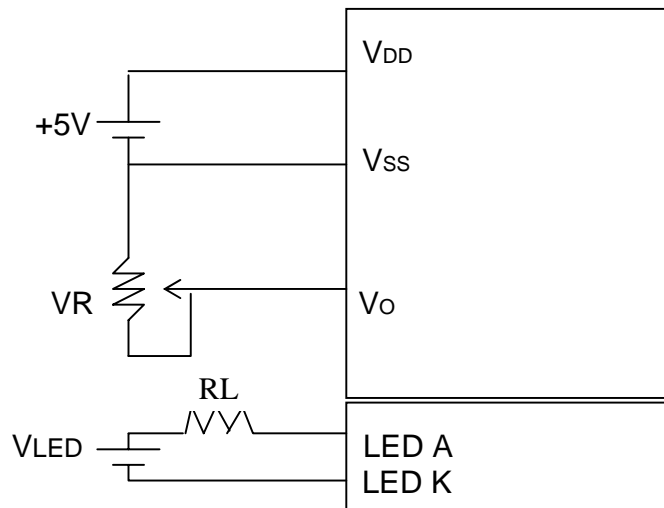

$VR = 10K$

RL: External current limit resistor.

10. BLOCK DIAGRAM

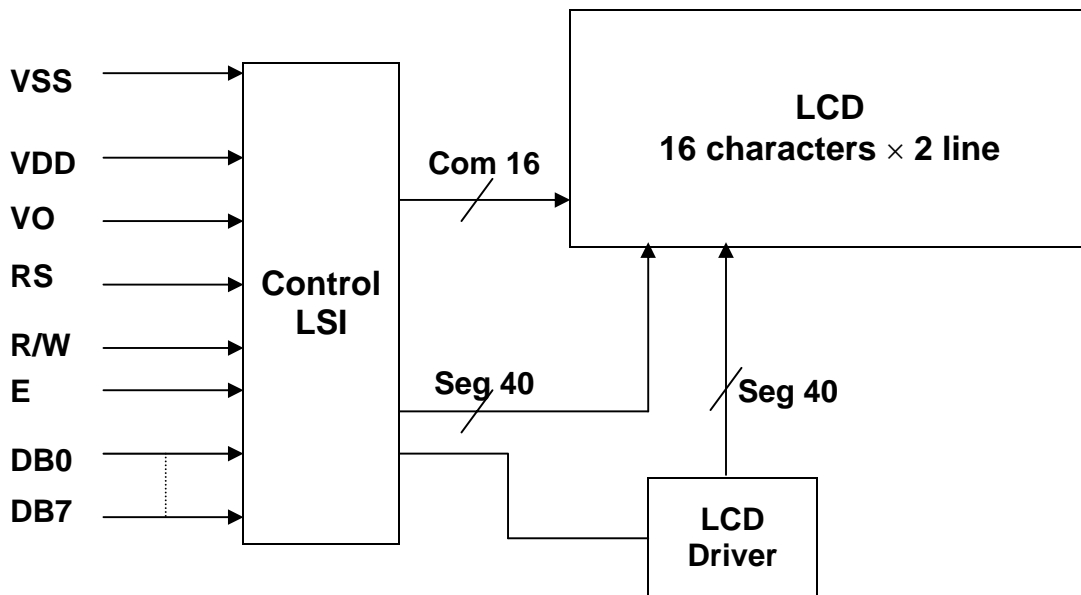



10.1 INSTRUCTIONS

Instruction	Instruction Code										DESCRIPTION	Executed Time(fosc =270KHz)
	RS	R/W	DB7	DB6	DB5	DB4	DB3	DB2	DB1	DB0		
Clear Display	0	0	0	0	0	0	0	0	0	1	Write "20H" to DDRAM and set DDRAM address to "00H" from AC	1.52mS
Cursor At Home	0	0	0	0	0	0	0	0	1	-	Set DDRAM address to "00H" from AC and return cursor to its original Position if shifted. The contents of DDRAM are not changed.	1.52mS
Entry Mode Set	0	0	0	0	0	0	0	1	I/D	SH	Assign cursor moving direction and enable the shift of entire display.	37μS
Display On/Off Control	0	0	0	0	0	0	1	D	C	B	Set display (D), cursor(C), and Blinking of cursor(B) ON/OFF control bit.	37μS
Cursor or Display Shift	0	0	0	0	0	1	S/C	R/L	-	-	Set cursor moving and display shifts cursor bit, and the direction, without changing of DDRAM data.	37μS
Function Set	0	0	0	0	1	DL	N	F	-	-	Sets interface data length (DL:8-BIT/4-BIT), number of display lines(N:2-line/1-line) and, display font type (F:5x11dots/5x8 dots).	37μS
Set CGRAM Address	0	0	0	1	AC5	AC4	AC3	AC2	AC1	AC0	Set CGRAM address in address counter.	37μS
Set DDRAM Address	0	0	1	AC6	AC5	AC4	AC3	AC2	AC1	AC0	Set DDRAM address in address counter.	37μS
Read Busy Flag and Address	0	1	BF	AC6	AC5	AC4	AC3	AC2	AC1	AC0	Whether during internal operation or not can be known by reading BF. The contents of address counter can also be read.	0μS
Write Data to RAM	1	0	D7	D6	D5	D4	D3	D2	D1	D0	Write data into internal RAM (DDRAM / CGRAM)	37μS
Read Data from RAM	1	1	D7	D6	D5	D4	D3	D2	D1	D0	Reads data from internal RAM (DDRAM / CGRAM).	37μS

Note:

Be sure the ST7066U is not in the busy state (BF=0) before sending an instruction from the MPU to the ST7066U. If an instruction is sent without checking the busy flag, the time between the first instruction and next instruction will take much longer than the instruction time itself. Refer to Instruction Table for the list of each instruction execution time.

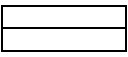
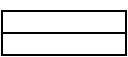
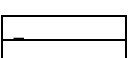
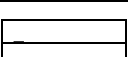
10.2 8-Bit Operation, 8-Digit×2-Line Display Example

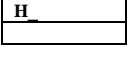
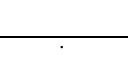
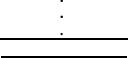
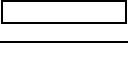
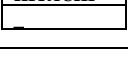
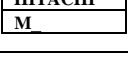
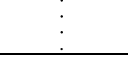
Step	Instruction										Display	Operation
No	RS	R/W	DB7	DB6	DB5	DB4	DB3	DB2	DB1	DB0		
1	Power supply on (the IC is initialized by the Internal reset circuit)											Initialized. No display.
2	Function set 0 0 0 0 1 1 1 0 * *											Sets to 8-bit operation and selects 2-line display and 5×8 dot character font.
3	Display on/off control 0 0 0 0 0 0 1 1 1 0											Turns on display and cursor. All display is in space mode because of initialization.
4	Entry mode set 0 0 0 0 0 0 0 1 1 0											Sets mode to increment the address by one and to shift the cursor to the right at the time of write to the DD/CGRAM. Display is not shifted.
5	Write data to CGRAM/DDRAM 1 0 0 1 0 0 1 0 0 0											Writes H. DDRAM has already been selected by initialization when the power was turned on. The cursor is incremented by one and shifted to the right
6	⋮										⋮	
7	Write data to CGRAM/DDRAM 1 0 0 1 0 0 1 0 0 1											Writes I.
8	Set DDRAM address 0 0 1 1 0 0 0 0 0 0											Sets DDRAM address so that The cursor is positioned at the Head of the second line.
9	Write data to CGRAM/DDRAM 1 0 0 1 0 0 1 1 0 1											Writes M.
10	⋮										⋮	
11	Write data to CGRAM/DDRAM 1 0 0 1 0 0 1 1 1 1											Writes O.
12	Entry mode set 0 0 0 0 0 0 0 1 1 1											Sets mode to shift display at the time of write.
13	Write data to CGRAM/DDRAM 1 0 0 1 0 0 1 1 0 1											Writes M. Display is shifted to the left. The first and second lines both shift at the same time.
14	⋮										⋮	
15	Return home 0 0 0 0 0 0 0 0 1 0											Returns both display and cursor to the original position (address 0).

10.3 Interfacing to the MPU

The IC can send data in either two 4-bit operations, thus allowing interfacing with 4- or 8-bit MPU.

- For 4-bit interface data, only four bus lines (DB4 to DB7) are used for transfer. Bus lines DB0 to DB3 are disabled. The data transfer between the IC and the MPU is completed after the 4-bit data has been transferred twice. As for the order of data transfer, the four high order bits (for 8-bit operation, DB4 to DB7) are transferred before the four low order bits (for 8-bit operation, DB0 to DB3). The busy flag must be checked (one instruction) after the 4-bit data has been transferred twice. Two more 4-bit operations then transfer the busy flag and address counter data.

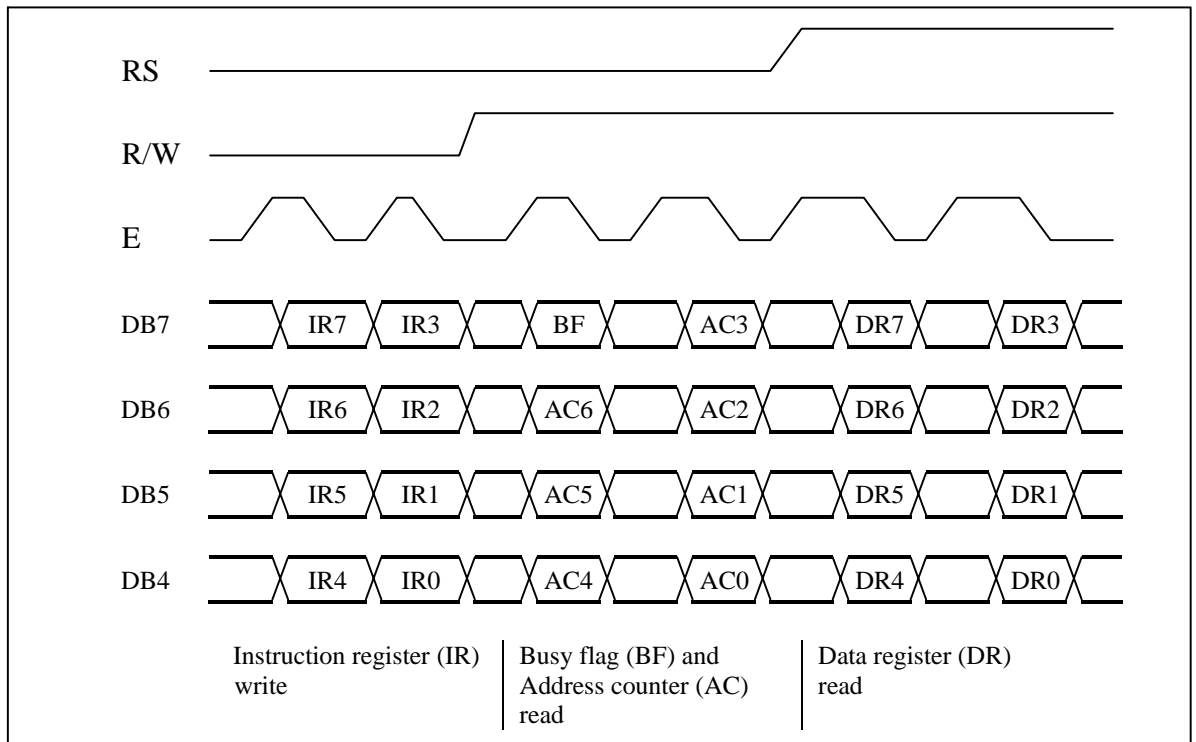

4-Bit Transfer Example

10.4
1-Line Display

Display position	1	2	3	4	5	6	7	8	9	10	11	12	13	14	15	16
DDRAM Address (hexadecimal)	00	01	02	03	04	05	06	07	40	41	42	43	44	45	46	47

← 16×1-Line →

2-Line Display

Display position	1	2	3	4	5	...	8	...	16	...	20	...	24	...	39	40	
DDRAM Address (hexadecimal)	00	01	02	03	04										26	27
	40	41	42	43	44										66	67

← 8×2-Line →

← 16×2-Line →

← 20×2-Line →

← 24×2-Line →

4-Line Display

Display position	1	2	3											15	16
DDRAM Address (hexadecimal)	00	01	02											0E	0F
	40	41	42											4E	4F
	14	15	16											1E	1F
	54	55	56											5E	5F

← 16×4 Line →

Display position	1	2	3															19	20
DDRAM Address (hexadecimal)	00	01	02															12	13
	40	41	42															52	53
	14	15	16															26	27
	54	55	56															66	67

← 20×4 Line →

10.5 CGRAM

Relationship between CGRAM Addresses, Character Codes (DDRAM) and Patterns (CGRAM Data)

For 5×8 dot character patterns

Character Codes (DDRAM data)		CGRAM Address		Character Patterns (CGRAM data)		
7 6 5 4 3 2 1 0		5 4 3 2 1 0		7 6 5 4 3 2 1 0		
High Low		High Low		High Low		
0 0 0 0 * 0 0 0		0 0 0	0 0 0	* * *	1 1 1 1 0	} Character Pattern (1)
			0 0 1	↑	1 0 0 0 1	
			0 1 0		1 0 0 0 1	
			0 1 1		1 1 1 1 0	
			1 0 0		1 0 1 0 0	
			1 0 1		1 0 0 1 0	
			1 1 0		1 0 0 0 1	
			1 1 1	↓	* * * 0 0 0 0 0	
0 0 0 0 * 0 0 1		0 0 1	0 0 0	* * *	1 0 0 0 1	} Character Pattern (2)
			0 0 1	↑	0 1 0 1 0	
			0 1 0		1 1 1 1 1	
			0 1 1		0 0 1 0 0	
			1 0 0		1 1 1 1 1	
			1 0 1		0 0 1 0 0	
			1 1 0		0 0 1 0 0	
			1 1 1	↓	* * * 0 0 0 0 0	
0 0 0 0 * 1 1 1		1 1 1	0 0 0	↑	* * *	} Cursor position
			0 0 1			
			1 0 0			
			1 0 1			
			1 1 0			
			1 1 1			
				↓		

- Notes :
- Character code bits 0 to 2 correspond to CGRAM address bits 3 to 5 (3 bits: 8 types).
 - CGRAM address bits 0 to 2 designate the character pattern line position. The 8th line is the cursor position and its display is formed by a logical OR with the cursor. Maintain the 8th line data, corresponding to the cursor display position, at 0 as the cursor display. If the 8th line data is 1, 1 bits will light up the 8th line regardless of the cursor presence.
 - Character pattern row positions correspond to CGRAM data bits 0 to 4 (bit 4 being at the left).
 - As shown Table 5, CGRAM character patterns are selected when character code bits 4 to 7 are all 0. However, since character code bit 3 has no effect, the R display example above can be selected by either character code 00H or 08H.
 - 1 for CGRAM data corresponds to display selection and 0 to non-selection.
- * Indicates no effect.

10.6 Correspondence between Character Codes and Character Patterns.

NO.7066-0A

<small>b7-b4 b3-b0</small>	0000	0001	0010	0011	0100	0101	0110	0111	1000	1001	1010	1011	1100	1101	1110	1111
0000	CG RAM (1)			0	1	2	3	4					5	6	7	8
0001	(2)	9	A	B	C	D	E	F			G	H	I	J	K	L
0010	(3)	M	N	O	P	Q	R	S			T	U	V	W	X	Y
0011	(4)	Z	[]	^	_	`	a			b	c	d	e	f	g
0100	(5)	h	i	j	k	l	m	n			o	p	q	r	s	t
0101	(6)	u	v	w	x	y	z	{				}	~	`	a	b
0110	(7)	c	d	e	f	g	h	i			j	k	l	m	n	o
0111	(8)	p	q	r	s	t	u	v			w	x	y	z	[]
1000	(1)	^	_	`	a	b	c	d			e	f	g	h	i	j
1001	(2)	k	l	m	n	o	p	q			r	s	t	u	v	w
1010	(3)	x	y	z	{	}	~	`			a	b	c	d	e	f
1011	(4)	g	h	i	j	k	l	m			n	o	p	q	r	s
1100	(5)	t	u	v	w	x	y	z			{	}	~	`	a	b
1101	(6)	c	d	e	f	g	h	i			j	k	l	m	n	o
1110	(7)	p	q	r	s	t	u	v			w	x	y	z	[]
1111	(8)	^	_	`	a	b	c	d			e	f	g	h	i	j

11. QUALITY ASSURANCE

11.1 Test Condition

11.1.1 Temperature and Humidity(Ambient Temperature)

Temperature : $20 \pm 5^{\circ}\text{C}$

Humidity : $65 \pm 5\%$

11.1.2 Operation

Unless specified otherwise, test will be conducted under function state.

11.1.3 Container

Unless specified otherwise, vibration test will be conducted to the product itself without putting it in a container.

11.1.4 Test Frequency

In case of related to deterioration such as shock test. It will be conducted only once.

11.1.5 Test Method

No.	Parameter	Conditions	Regulations
1	High Temperature Operating	$70 \pm 2^{\circ}\text{C}$, 96h	Note 3
2	Low Temperature Operating	$-20 \pm 2^{\circ}\text{C}$, 96h	Note 3
3	High Temperature Storage	$80 \pm 2^{\circ}\text{C}$, 96h	Note 3
4	Low Temperature Storage	$-30 \pm 2^{\circ}\text{C}$, 96h	Note 3
5	Vibration Test (Non-operation state)	Total fixed amplitude : 1.5mm Vibration Frequency : 10 ~ 55Hz One cycle 60 seconds to 3 directions of X.Y.Z. for each 15 minutes	Note 3
6	Damp Proof Test (Non-operation state)	$40^{\circ}\text{C} \pm 2^{\circ}\text{C}$, 90~95%RH, 96h	Note 1,2
7	Shock Test (Non-operation state)	To be measured after dropping from 60cm high once concrete surface in packing state	Note 3

Note 1: Returned under normal temperature and humidity for 4 hrs.

Note 2: No dew condensation to be observed.

Note 3: No change on display and in operation under the test condition

11.2 Inspection condition

11.2.1 Inspection conditions

The LCD shall be inspected under 40W white fluorescent light.

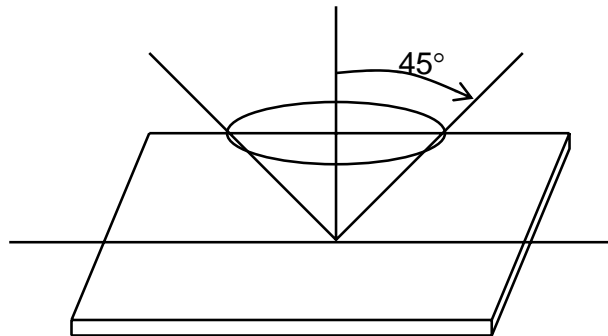

11.2.2 Definition of applicable Zones

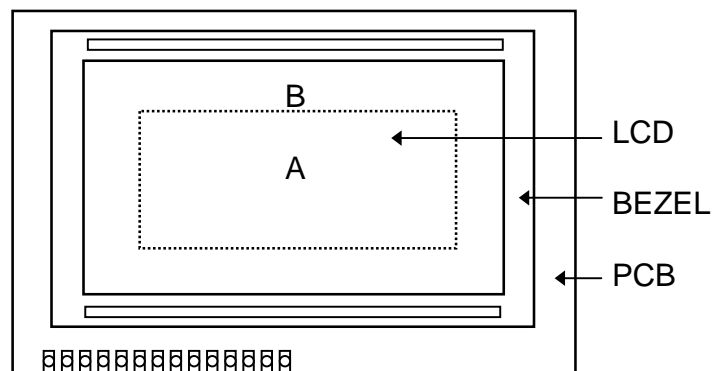

A : Display Area
B : Non-Display Area

11.2.3 Inspection Parameters

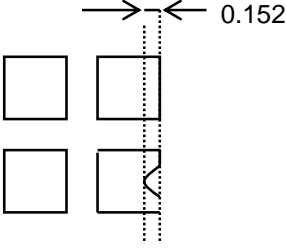
No.	Parameter	Criteria																												
1	Black or White spots	<table border="1"> <thead> <tr> <th rowspan="2">Zone Dimension</th> <th colspan="2">Acceptable number</th> <th rowspan="2">Class Of Defects</th> <th rowspan="2">AQL Level</th> </tr> <tr> <th>A</th> <th>B</th> </tr> </thead> <tbody> <tr> <td>$D < 0.15$</td> <td>*</td> <td>*</td> <td rowspan="4">Minor</td> <td rowspan="4">2.5</td> </tr> <tr> <td>$0.15 \leq D < 0.2$</td> <td>4</td> <td>4</td> </tr> <tr> <td>$0.2 \leq D \leq 0.25$</td> <td>2</td> <td>2</td> </tr> <tr> <td>$D \leq 0.3$</td> <td>0</td> <td>1</td> </tr> </tbody> </table> <p style="text-align: center;">$D = (\text{Long} + \text{Short}) / 2$ * : Disregard</p>	Zone Dimension	Acceptable number		Class Of Defects	AQL Level	A	B	$D < 0.15$	*	*	Minor	2.5	$0.15 \leq D < 0.2$	4	4	$0.2 \leq D \leq 0.25$	2	2	$D \leq 0.3$	0	1							
Zone Dimension	Acceptable number			Class Of Defects	AQL Level																									
	A	B																												
$D < 0.15$	*	*	Minor	2.5																										
$0.15 \leq D < 0.2$	4	4																												
$0.2 \leq D \leq 0.25$	2	2																												
$D \leq 0.3$	0	1																												
2	Scratch, Substances	<table border="1"> <thead> <tr> <th colspan="2">Zone</th> <th colspan="2">Acceptable number</th> <th rowspan="2">Class Of Defects</th> <th rowspan="2">AQL Level</th> </tr> <tr> <th>X (mm)</th> <th>Y (mm)</th> <th>A</th> <th>B</th> </tr> </thead> <tbody> <tr> <td>*</td> <td>$0.04 \geq W$</td> <td>*</td> <td>*</td> <td rowspan="4">Minor</td> <td rowspan="4">2.5</td> </tr> <tr> <td>$3.0 \geq L$</td> <td>$0.06 \geq W$</td> <td>4</td> <td>4</td> </tr> <tr> <td>$2.0 \geq L$</td> <td>$0.08 \geq W$</td> <td>2</td> <td>3</td> </tr> <tr> <td>—</td> <td>$0.1 < W$</td> <td>0</td> <td>1</td> </tr> </tbody> </table> <p style="text-align: center;">X : Length Y : Width * : Disregard Total defects should not exceed 4/module</p>	Zone		Acceptable number		Class Of Defects	AQL Level	X (mm)	Y (mm)	A	B	*	$0.04 \geq W$	*	*	Minor	2.5	$3.0 \geq L$	$0.06 \geq W$	4	4	$2.0 \geq L$	$0.08 \geq W$	2	3	—	$0.1 < W$	0	1
Zone		Acceptable number		Class Of Defects	AQL Level																									
X (mm)	Y (mm)	A	B																											
*	$0.04 \geq W$	*	*	Minor	2.5																									
$3.0 \geq L$	$0.06 \geq W$	4	4																											
$2.0 \geq L$	$0.08 \geq W$	2	3																											
—	$0.1 < W$	0	1																											
3	Air Bubbles (between glass & polarizer)	<table border="1"> <thead> <tr> <th rowspan="2">Zone Dimension</th> <th colspan="2">Acceptable number</th> <th rowspan="2">Class of Defects</th> <th rowspan="2">AQL Level</th> </tr> <tr> <th>A</th> <th>B</th> </tr> </thead> <tbody> <tr> <td>$D \leq 0.15$</td> <td>*</td> <td>*</td> <td rowspan="3">Minor</td> <td rowspan="3">2.5</td> </tr> <tr> <td>$0.15 < D \leq 0.25$</td> <td>2</td> <td>*</td> </tr> <tr> <td>$0.25 < D$</td> <td>0</td> <td>1</td> </tr> </tbody> </table> <p style="text-align: center;">* : Disregard Total defects shall not excess 3/module.</p>	Zone Dimension	Acceptable number		Class of Defects	AQL Level	A	B	$D \leq 0.15$	*	*	Minor	2.5	$0.15 < D \leq 0.25$	2	*	$0.25 < D$	0	1										
Zone Dimension	Acceptable number			Class of Defects	AQL Level																									
	A	B																												
$D \leq 0.15$	*	*	Minor	2.5																										
$0.15 < D \leq 0.25$	2	*																												
$0.25 < D$	0	1																												
4	Uniformity of Pixel	<p>(1) Pixel shape (with Dent)</p> 																												

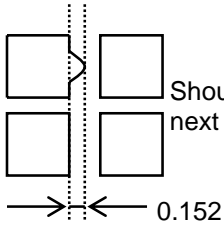
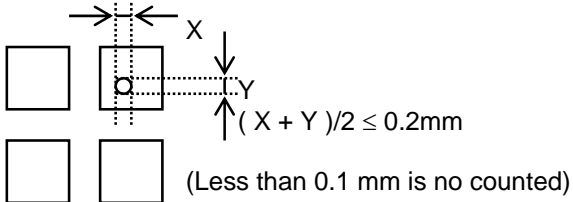
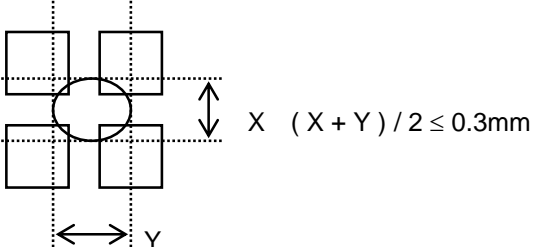
4	Uniformity of Pixel	(2) Pixel shape (with Projection)	
		 <p>Should not be connected to next pixel</p>	
		(3) Pin hole	
		 <p>(Less than 0.1 mm is no counted)</p>	
		(4) Deformation	
		 <p>$(X + Y) / 2 \leq 0.3\text{mm}$</p>	
		Total acceptable number : 1/pixel, 5/cell	
Class of defects	Major	AQL 0.65	Definition It is a defect that is likely to result in failure or to reduce materially the usability of the product for the intended function.
		AQL 1.00	It is a defect that is likely to assembly size and not result in functioning problem.
	Minor	AQL 2.5	It is a defect that will not result in functioning problem with deviation classified.

11.3 Sampling Condition

Unless otherwise agree in written, the sampling inspection shall be applied to the incoming inspection of customer.

Lot size: Quantity of shipment lot per model.

Sampling type: normal inspection, single sampling

Sampling table: MIL-STD-105E

Inspection level: Level II

12. LCM PRODUCT LABEL DEFINE

Product Label style:

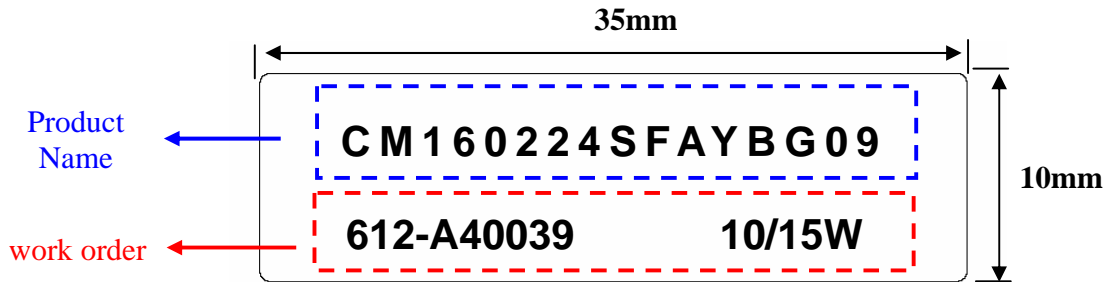

Work order Define:

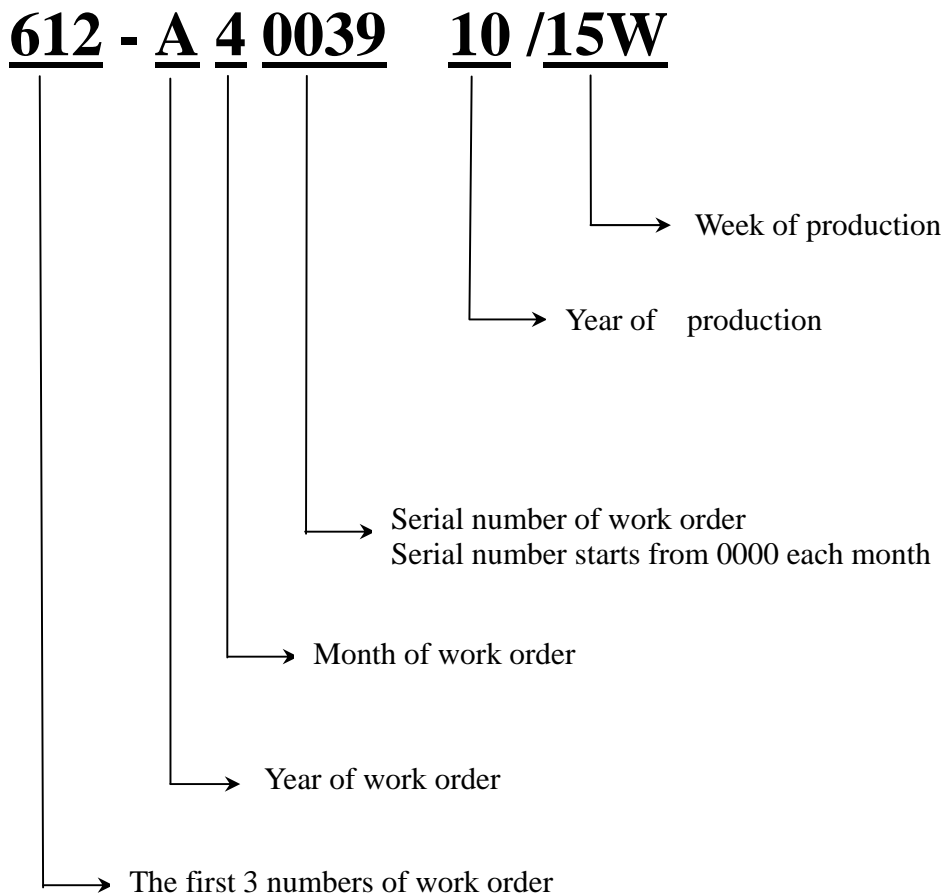

Product Name Define:

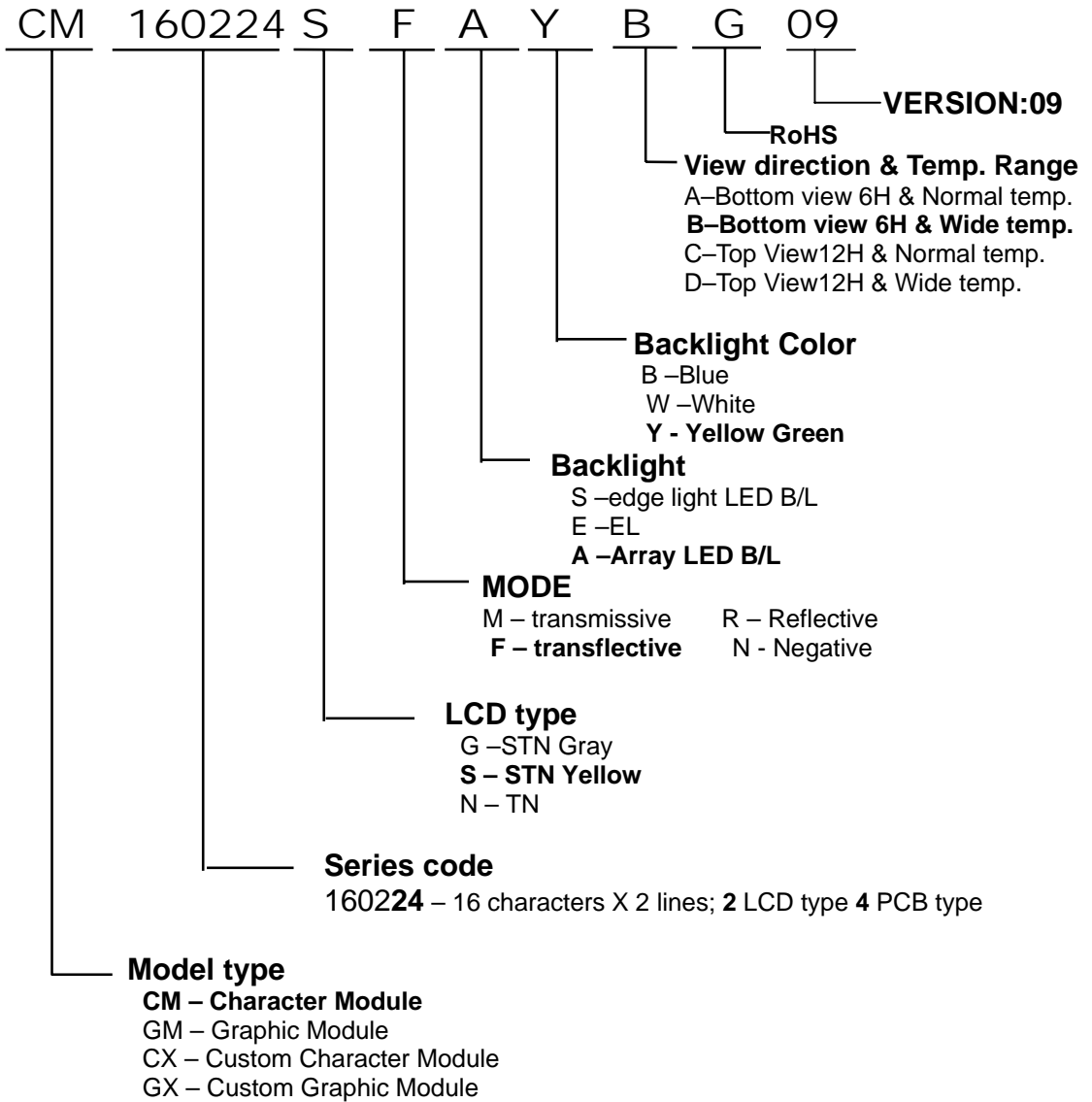

13. PRECAUTIONS IN USE LCM

1. LIQUID CRYSTAL DISPLAY (LCD)

LCD is made up of glass, organic sealant, organic fluid, and polymer based polarizers. The following precautions should be taken when handling,

- (1). Keep the temperature within range of use and storage. Excessive temperature and humidity could cause polarization degradation, polarizer peel off or bubble.
- (2). Do not contact the exposed polarizers with anything harder than an HB pencil lead. To clean dust off the display surface, wipe gently with cotton, chamois or other soft material soaked in petroleum benzin.
- (3). Wipe off saliva or water drops immediately. Contact with water over a long period of time may cause polarizer deformation or color fading, while an active LCD with water condensation on its surface will cause corrosion of ITO electrodes.
- (4). Glass can be easily chipped or cracked from rough handling, especially at corners and edges.
- (5). Do not drive LCD with DC voltage.

2. Liquid Crystal Display Modules

2.1 Mechanical Considerations

LCM are assembled and adjusted with a high degree of precision. Avoid excessive shocks and do not make any alterations or modifications. The following should be noted.

- (1). Do not tamper in any way with the tabs on the metal frame.
- (2). Do not modify the PCB by drilling extra holes, changing its outline, moving its components or modifying its pattern.
- (3). Do not touch the elastomer connector, especially insert an backlight panel (for example, EL).
- (4). When mounting a LCM make sure that the PCB is not under any stress such as bending or twisting. Elastomer contacts are very delicate and missing pixels could result from slight dislocation of any of the elements.
- (5). Avoid pressing on the metal bezel, otherwise the elastomer connector could be deformed and lose contact, resulting in missing pixels.

2.2. Static Electricity

LCM contains CMOS LSI's and the same precaution for such devices should apply, namely

- (1). The operator should be grounded whenever he/she comes into contact with the module. Never touch any of the conductive parts such as the LSI pads, the copper leads on the PCB and the interface terminals with any parts of the human body.
- (2). The modules should be kept in antistatic bags or other containers resistant to static for storage.
- (3). Only properly grounded soldering irons should be used.
- (4). If an electric screwdriver is used, it should be well grounded and shielded from commutator sparks.

- (5) The normal static prevention measures should be observed for work clothes and working benches; for the latter conductive (rubber) mat is recommended.
- (6). Since dry air is inductive to statics, a relative humidity of 50-60% is recommended.

2.3 Soldering

- (1). Solder only to the I/O terminals.
- (2). Use only soldering irons with proper grounding and no leakage.
- (3). Soldering temperature : $280^{\circ}\text{C} \pm 10^{\circ}\text{C}$
- (4). Soldering time: 3 to 4 sec.
- (5). Use eutectic solder with resin flux fill.
- (6). If flux is used, the LCD surface should be covered to avoid flux spatters. Flux residue should be removed after wards.

2.4 Operation

- (1). The viewing angle can be adjusted by varying the LCD driving voltage V_0 .
- (2). Driving voltage should be kept within specified range; excess voltage shortens display life.
- (3). Response time increases with decrease in temperature.
- (4). Display may turn black or dark blue at temperatures above its operational range; this is (however not pressing on the viewing area) may cause the segments to appear "fractured".
- (5). Mechanical disturbance during operation (such as pressing on the viewing area) may cause the segments to appear "fractured".

2.5 Storage

If any fluid leaks out of a damaged glass cell, wash off any human part that comes into contact with soap and water. Never swallow the fluid. The toxicity is extremely low but caution should be exercised at all the time.

2.6 Limited Warranty

Unless otherwise agreed between DATA IMAGE and customer, DATA IMAGE will replace or repair any of its LCD and LCM which is found to be defective electrically and visually when inspected in accordance with DATA IMAGE acceptance standards, for a period on one year from date of shipment. Confirmation of such date shall be based on freight documents. The warranty liability of DATA IMAGE is limited to repair and/or replacement on the terms set forth above. DATA IMAGE will not responsible for any subsequent or consequential events.

Confidential Document
14. OUTLINE DRAWING

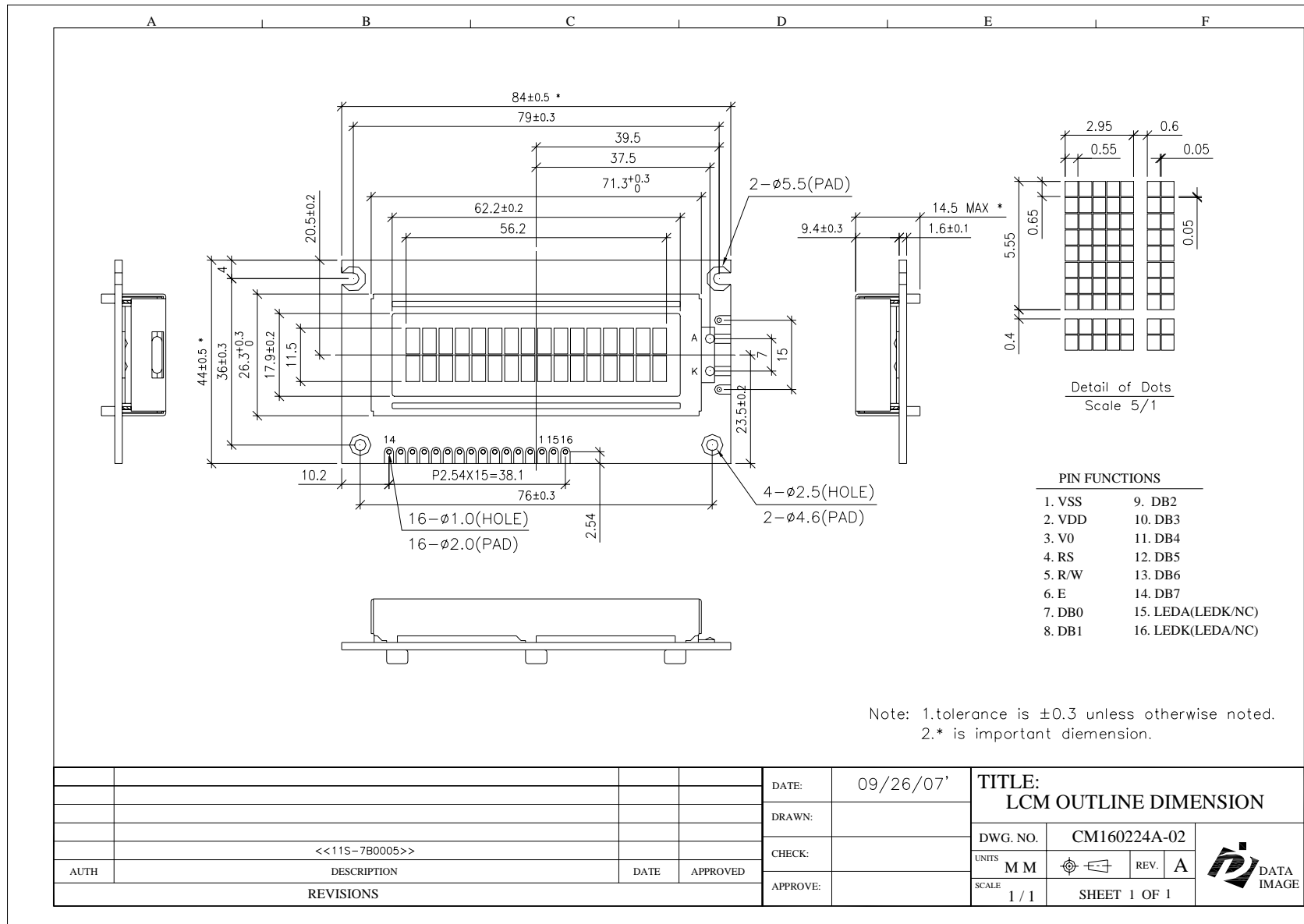

15. PACKAGE INFORMATION

