

PRODUCT SPECIFICATION

16*2 CHARACTER LCD MODULE MODEL: C1602Q8SKW6B-D0 Ver:1.0

- <◇> Preliminary Specification
- <◆> Finally Specification

CUSTOMER'S APPROVAL	
CUSTOMER :	
SIGNATURE:	DATE:

APPROVED BY	PM REVIEWED	PD REVIEWED	PREPARED BY
 2014.9.26	 2014.9.26	 9.26	周雁

Table of Contents

No.	Contents	Page
1.	FEATURES	4
2.	MECHANICAL SPECIFICATIONS	4
3.	ELECTRICAL SPECIFICATIONS	4
4.	TERMINAL FUNCTIONS AND BLOCK DIAGRAM.....	6
5.	TIMING CHARACTERISTICS	7
6	COMMAND LIST	11
7.	CHARACTER GENERATOR ROM.....	14
8.	QUALITY SPECIFICATIONS.....	15
9.	RELIABILITY.....	20
10.	HANDLING PRECAUTION	21
11.	OUTLINE DIMENSION	22
12	PACKING INSTRUCTION	23

1. Features

The features of LCD are showed as follows

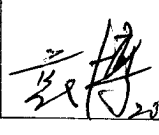
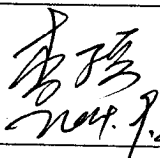
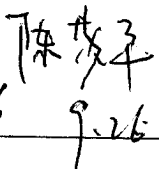
- * Display mode : STN/Gray/Transflective/ Positive
- * Controller IC : ST7066U-0A(English-Japanese)
- * Display format : 16X2 Characters
- * Interface Input Data : 4 bit or 8 bit MPU
- * Driving Method : 1/16Duty, 1/5Bias
- * Viewing Direction : 6 O'clock
- * Backlight : 2 LED/Side White
- *Sample NO. : C1602Q8SKW6B-D0_01/20140926

2. MECHANICAL SPECIFICATIONS

Item	Specification	Unit
Module Size	122(W) x 44(H) x 13.3(D)	mm
Viewing Area	99(W) x 25(H)	mm
Activity Display Area	94.84(W)x19.56(H)	mm
Character Font	5x8 Dots	-
Character Size	4.84(W)x9.22 (H)	mm
Character Pitch	6(W)x10.34(H)	mm
Dot Size	0.92(W)x1.1(H)	mm

3. ELECTRICAL SPECIFICATIONS

3-1 ABSOLUTE MAXIMUM RATINGS (Ta = 25 °C)

Item	Symbol	Min	Max	Unit
Supply Voltage For Logic	V _{DD}	-0.3	+7	V
Supply Voltage For LCD Drive	V _{LCD}	V _{DD} -10.0	V _{DD} +0.3	V
Input Voltage	V _{in}	-0.3	V _{DD} +0.3	V
Operating Temp.	T _{op}	-20	+70	°C
Storage Temp.	T _{st}	-30	+80	°C

*. NOTE: The response time will be extremely slow when the operating temperature is around -10°C, and the back ground will become darker at high temperature operating.

3-2 ELECTRICAL CHARACTERISTICS

Item		Symbol	Test Condition	Min.	Typ.	Max.	Unit
Logic supply Voltage		$V_{DD} - V_{SS}$	Ta = 25 °C VDD=5V ± 5%	-	5	-	V
LCD Drive		$V_{OP} = V_{DD} - V_0$		4.3	4.5	4.7	V
Input Voltage	"H" Level (Except OSC1)	V_{IH1}		$0.7 V_{DD}$	-	V_{DD}	V
	"L" Level (Except OSC1)	V_{IL1}		-0.3	-	0.6	V
	"H" Level (OSC1)	V_{IH2}		$0.7 V_{DD}$	-	V_{DD}	V
	"L" Level (OSC1)	V_{IL2}		-	-	$0.2 V_{DD}$	V
Frame Frequency		f_{FLM}		-	75	-	Hz
Current Consumption		I_{DD}		-	1.45	-	mA

3-3 BACKLIGHT**3-3-1. Absolute Maximum Ratings**

Item	Symbol	Condition	min	Typ	Max	Unit
Forward Current	IF	Ta = 25 °C	-	-	50	mA
Power Dissipation	PD		-	-	165	mW
Reverse Current	IR	VR=5.0V/LED	-	-	15	uA

3-3-2. Electrical-optical Characteristics

Item	Symbol	Condition	min		Typ		Max		Unit
Forward Current	IF	Vf=3.3V Ta = 25 °C	-		30		40		mA
Average Luminous Intensity	Iv		-		280		-		cd/m ²
Colour coordonate	-		X	Y	X	Y	X	Y	-
			0.25	0.25	0.28	0.28	0.31	0.31	

The brightness is measured without LCD panel

For operation above 25 °C, The I_{fm} & P_d must be derated, the current derating is -0.36mA/ °C for DC drive and -0.86mA/ °C for Pulse drive, the Power dissipation is -0.75mW/ °C. The product working current must not more than the 60% of the I_{fm} or I_{fp} according to the working temperature.

Backlight lifetime means luminance value larger than half of the original after 20000 hours' continuous working.

4. TERMINAL FUNCTIONS AND BLOCK DIAGRAM

4-1 INTERFACE PIN FUNCTION DESCRIPTION

PIN NO.	SYMBOL	FUNCTIONS
1	LED_K	Backlight(-)
2	LED_A	Backlight(+5V)
3	VSS	Ground
4	VDD	Supply voltage for logical circuit
5	V0	Supply voltage for LCD driving
6	RS	A signal for selecting registers. 1: Data Register (for read and write) 0: Instruction Register (for write)
7	R/W	A signal for selecting read or write actions.1: Read, 0: Write.
8	E	A enable signal for reading or writing data.
9-16	DB0~DB7	8 Bit Data Bus

4-2 BLOCK DIAGRAM

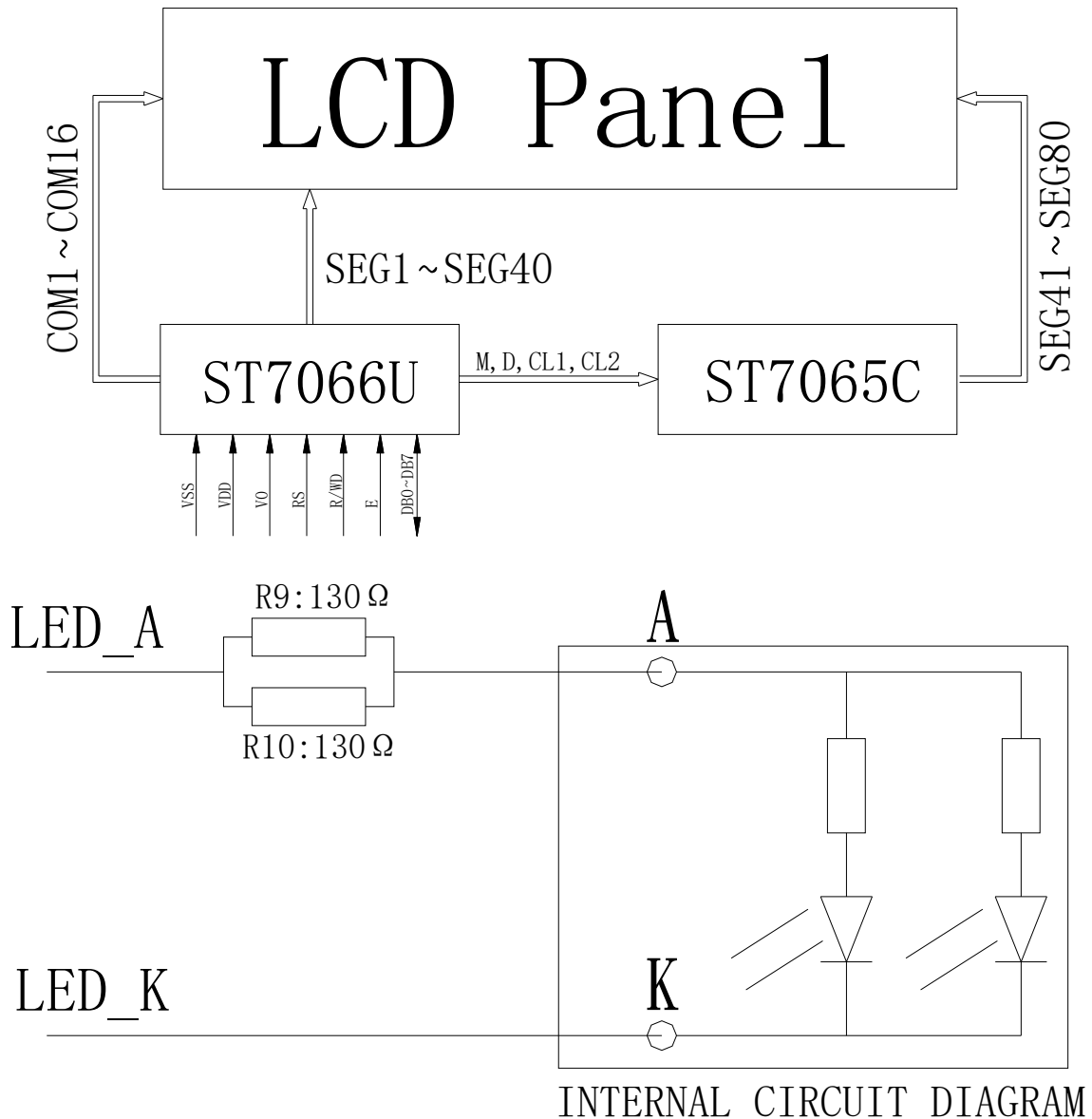

5. TIMING CHARACTERISTICS

5-1 Reading data from ST7066U to MPU

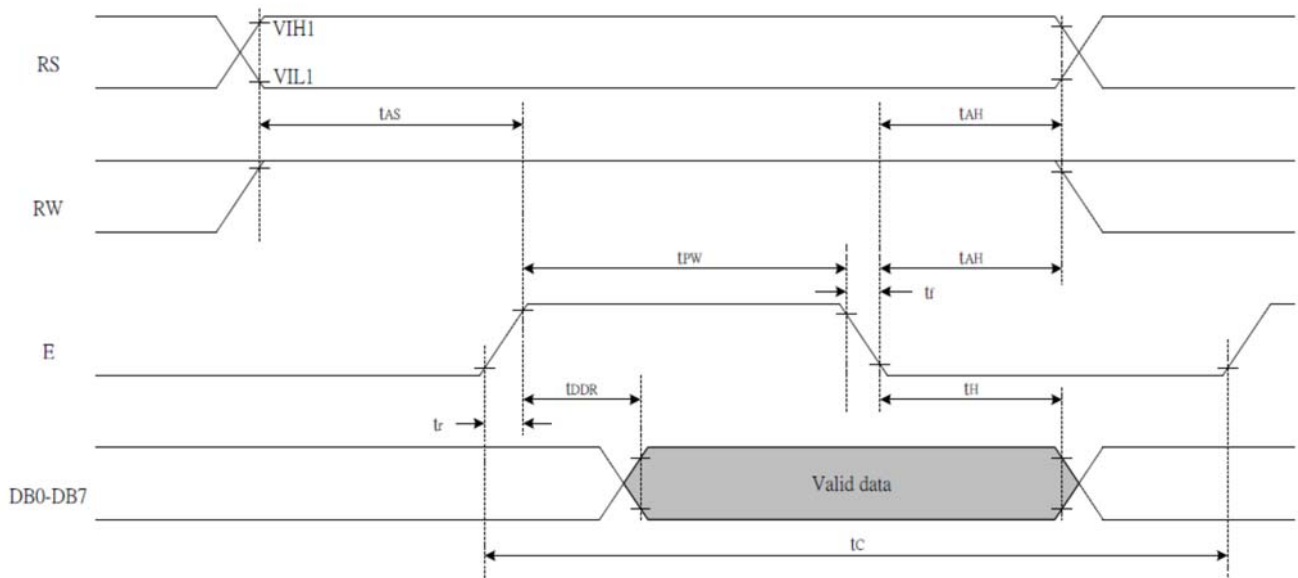

($T_A = 25^\circ\text{C}$, $V_{CC} = 5\text{V}$)

T_C	Enable Cycle Time	Pin E	1200	-	-	ns
T_{PW}	Enable Pulse Width	Pin E	140	-	-	ns
T_R, T_F	Enable Rise/Fall Time	Pin E	-	-	25	ns
T_{AS}	Address Setup Time	Pins: RS,RW,E	0	-	-	ns
T_{AH}	Address Hold Time	Pins: RS,RW,E	10	-	-	ns
T_{DDR}	Data Setup Time	Pins: DB0 - DB7	-	-	100	ns
T_H	Data Hold Time	Pins: DB0 - DB7	10	-	-	ns

5-2 Writing data from MPU to ST7066U

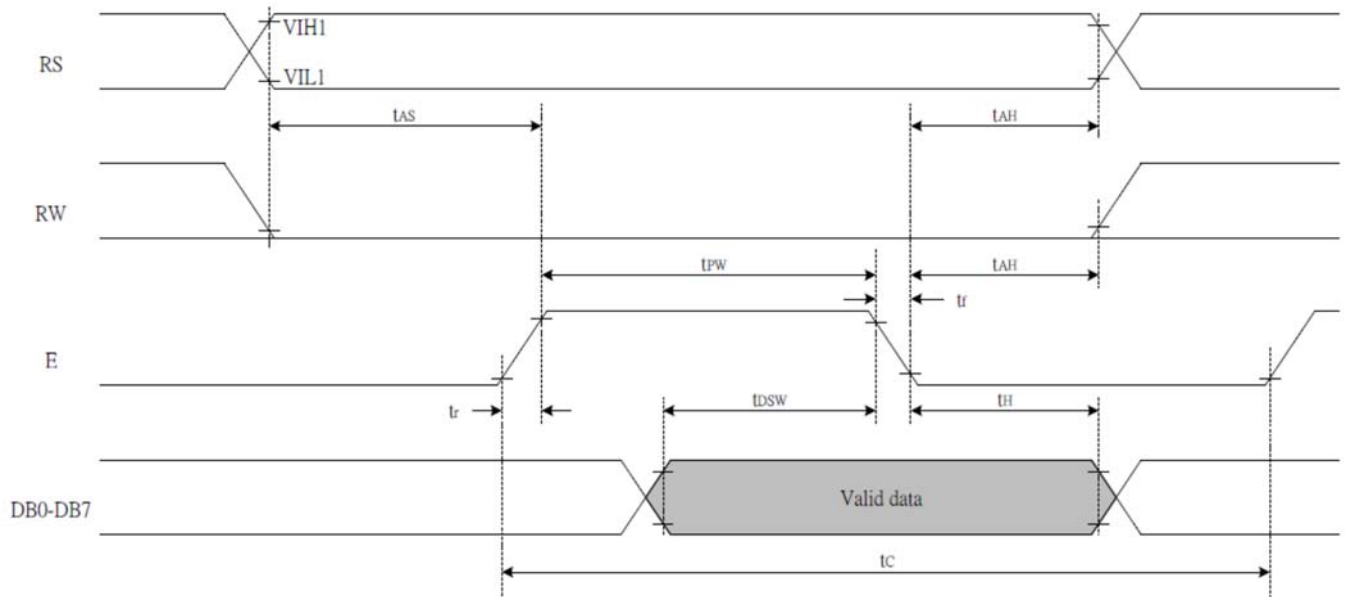

(TA = 25°C, VCC = 5V)

T _C	Enable Cycle Time	Pin E	1200	-	-	ns
T _{PW}	Enable Pulse Width	Pin E	140	-	-	ns
T _R , T _F	Enable Rise/Fall Time	Pin E	-	-	25	ns
T _{AS}	Address Setup Time	Pins: RS,RW,E	0	-	-	ns
T _{AH}	Address Hold Time	Pins: RS,RW,E	10	-	-	ns
T _{DSW}	Data Setup Time	Pins: DB0 - DB7	40	-	-	ns
T _H	Data Hold Time	Pins: DB0 - DB7	10	-	-	ns

5-3 Interface Timing with External Driver

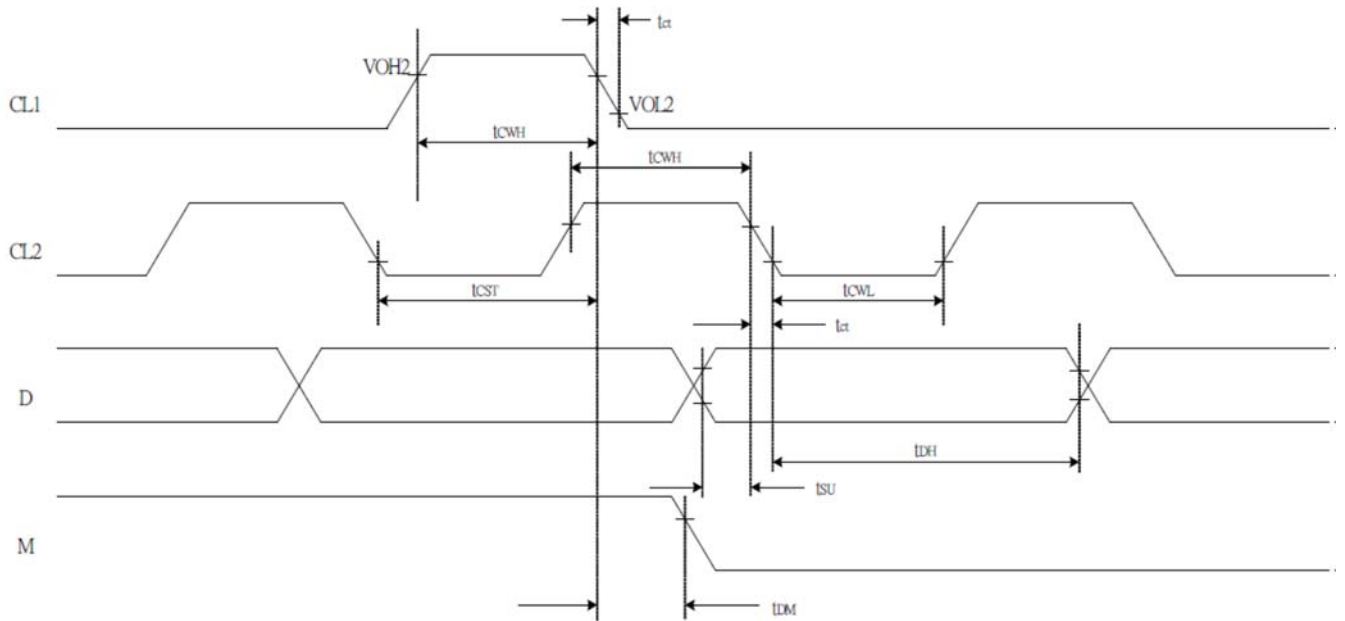

(TA = 25°C, VCC = 5V)

T_{CWH}	Clock Pulse with High	Pins: CL1, CL2	800	-	-	ns
T_{CWL}	Clock Pulse with Low	Pins: CL1, CL2	800	-	-	ns
T_{CST}	Clock Setup Time	Pins: CL1, CL2	500	-	-	ns
T_{SU}	Data Setup Time	Pin: D	300	-	-	ns
T_{DH}	Data Hold Time	Pin: D	300	-	-	ns
T_{DM}	M Delay Time	Pin: M	0	-	2000	ns

5-4 Power Supply Conditions

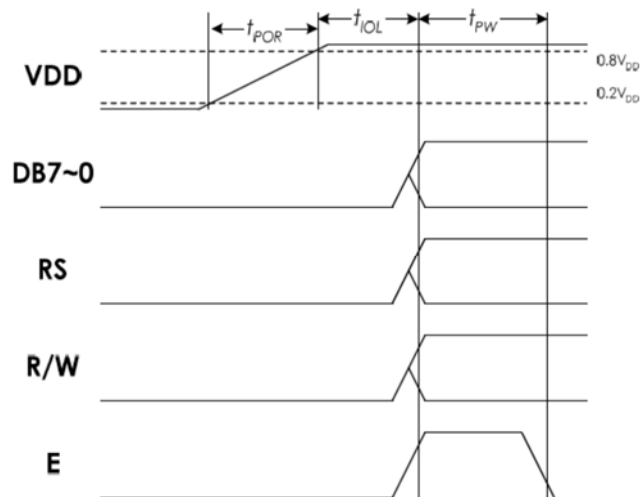

Symbol	Characteristics	Description	Min.	Typ.	Max.	Unit
tPOR	Power rise time	Power rise time that will trigger internal power on reset circuit	0.1		100	ms
tIOL	I/O Low time	The period that I/O is kept low.	40			ms
tPW	Enable pulse width	Please refer to the following tables.				

1. During t_{POR}, VDD noise should be reduced (especially close to 2.0V). Otherwise the Power-ON-Reset function might be triggered several times and maybe cause unexpected result.
2. During t_{IOL}, the I/O ports of the interface (control and data signals) should be kept at "Low".

6 COMMAND LIST

6-1 Instruction Table

Instruction	Instruction Code										Description	Description Time (270KHz)	
	RS	R/W	DB7	DB6	DB5	DB4	DB3	DB2	DB1	DB0			
Clear Display	0	0	0	0	0	0	0	0	0	0	1	Write "20H" to DDRAM. and set DDRAM address to "00H" from AC	1.52 ms
Return Home	0	0	0	0	0	0	0	0	0	1	x	Set DDRAM address to "00H" from AC and return cursor to its original position if shifted. The contents of DDRAM are not changed.	1.52 ms
Entry Mode Set	0	0	0	0	0	0	0	0	1	I/D	S	Sets cursor move direction and specifies display shift. These operations are performed during data write and read.	37 us
Display ON/OFF	0	0	0	0	0	0	0	1	D	C	B	D=1:entire display on C=1:cursor on B=1:cursor position on	37 us
Cursor or Display Shift	0	0	0	0	0	0	1	S/C	R/L	x	x	Set cursor moving and display shift control bit, and the direction, without changing DDRAM data.	37 us
Function Set	0	0	0	0	0	1	DL	N	F	x	x	DL:interface data is 8/4 bits N:number of line is 2/1 F:font size is 5x11/5x8	37 us
Set CGRAM address	0	0	0	1	AC5	AC4	AC3	AC2	AC1	AC0		Set CGRAM address in address counter	37 us
Set DDRAM address	0	0	1	AC6	AC5	AC4	AC3	AC2	AC1	AC0		Set DDRAM address in address counter	37 us
Read Busy flag and address	0	1	BF	AC6	AC5	AC4	AC3	AC2	AC1	AC0		Whether during internal operation or not can be known by reading BF. The contents of address counter can also be read.	0 us
Write data to RAM	1	0	D7	D6	D5	D4	D3	D2	D1	D0		Write data into internal RAM (DDRAM/CGRAM)	37 us
Read data from RAM	1	1	D7	D6	D5	D4	D3	D2	D1	D0		Read data from internal RAM (DDRAM/CGRAM)	37 us

Note:

Be sure the ST7066U is not in the busy state (BF = 0) before sending an instruction from the MPU to the ST7066U. If an instruction is sent without checking the busy flag, the time between the first instruction and next instruction will take much longer than the instruction time itself. Refer to Instruction Table for the list of each instruction execution time.

6-2 Initializing by Instruction

6-2-1 8-bit Interface (fosc=270KHz)

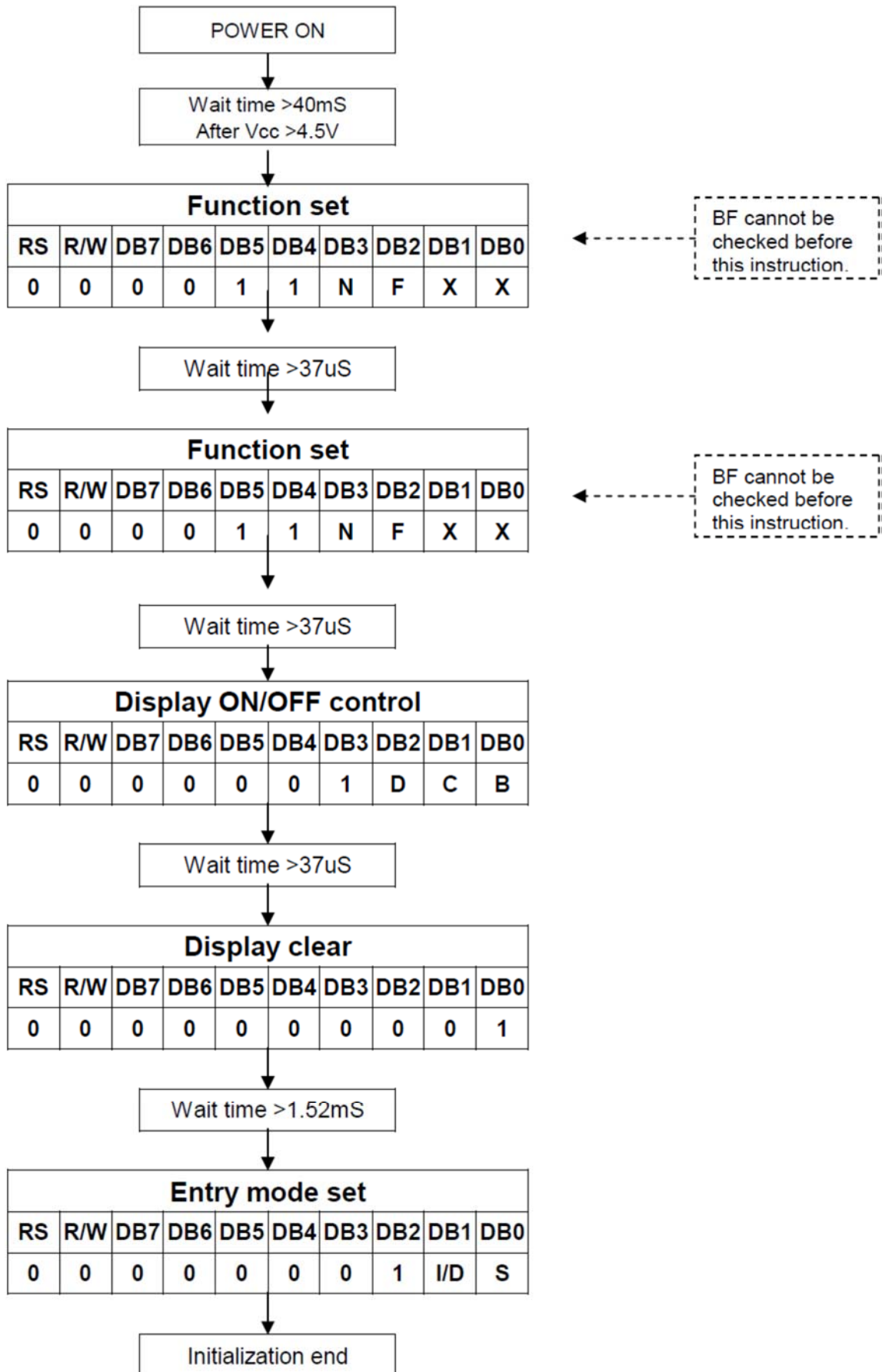

6-2-2 4-bit Interface (fosc=270KHz)

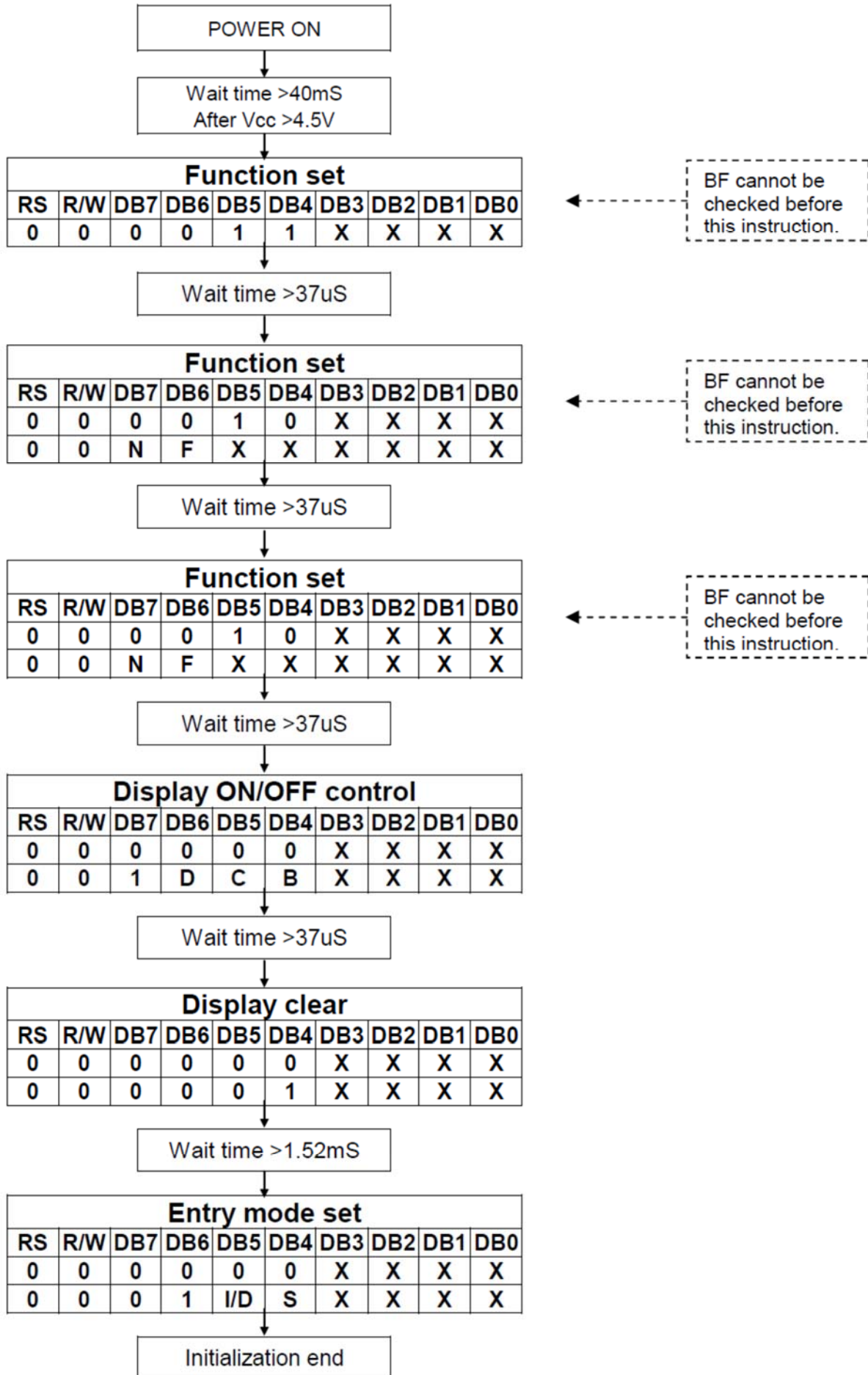

7.CHARACTER GENERATOR ROM

b7-b4 b3-b0	0000	0001	0010	0011	0100	0101	0110	0111	1000	1001	1010	1011	1100	1101	1110	1111
0000	CG RAM (1)			0	a	P	\	P				-	9	R	Q	P
0001	(2)		!	1	A	Q	a	q			.	7	*	4	3	q
0010	(3)		"	2	B	R	b	r			^	4	9	x	P	B
0011	(4)		#	3	C	S	c	s			^	9	7	e	e	*
0100	(5)		\$	4	D	T	d	t			\	I	I	k	u	a
0101	(6)		%	5	E	U	e	u			.	*	*	1	c	0
0110	(7)		&	6	F	V	f	v			9	0	=	3	p	z
0111	(8)		'	7	G	W	g	w			7	*	x	9	g	π
1000	(1)		(8	H	X	h	x			4	0	*	U	J	x
1001	(2))	9	I	Y	i	y			9	7	^	u	^	y
1010	(3)		*	:	J	Z	j	z			=	0	n	v	j	*
1011	(4)		+	;	K	L	k	l			*	9	E	0	x	π
1100	(5)		,	<	L	*	l	l			9	9	7	7	*	π
1101	(6)		-	=	N	J	n	j			a	x	>	u	t	+
1110	(7)		.	>	N	^	n	^			3	E	*	^	n	
1111	(8)		/	?	O	_	o	_			9	9	7	*	0	■

8. QUALITY SPECIFICATIONS

8-1. LCM Appearance and Electric inspection Condition

1. Inspection will be done by placing LCM 30cm away from inspector's eyeballs under normal illumination.

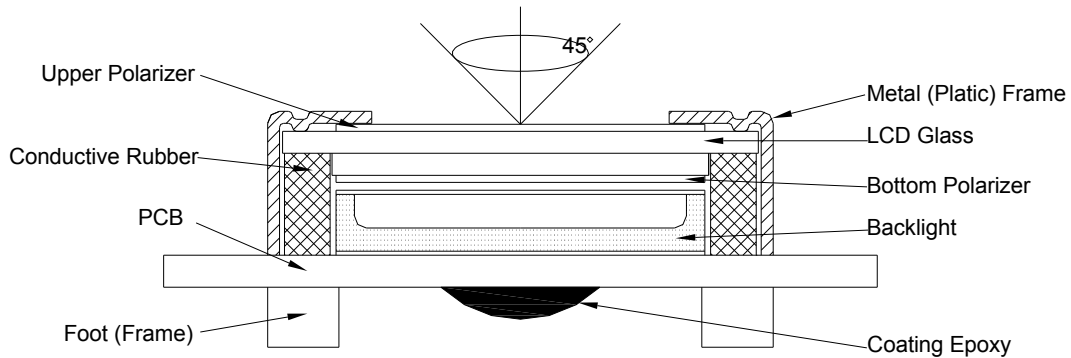

2. View Angle: with in 45° around perpendicular line.

8-2. Definition

1. COB

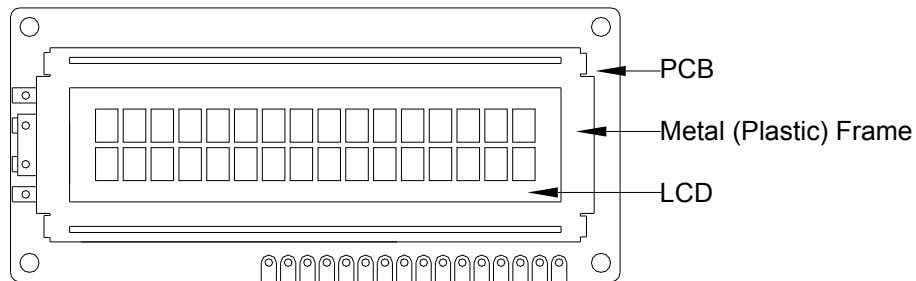

2. Heat Seal

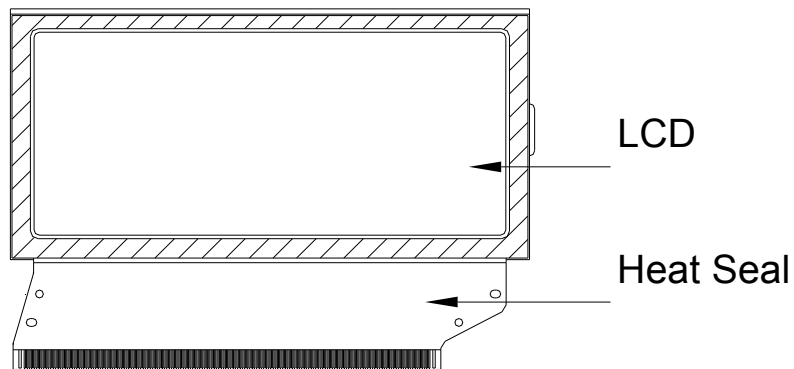

3. TAB and COG

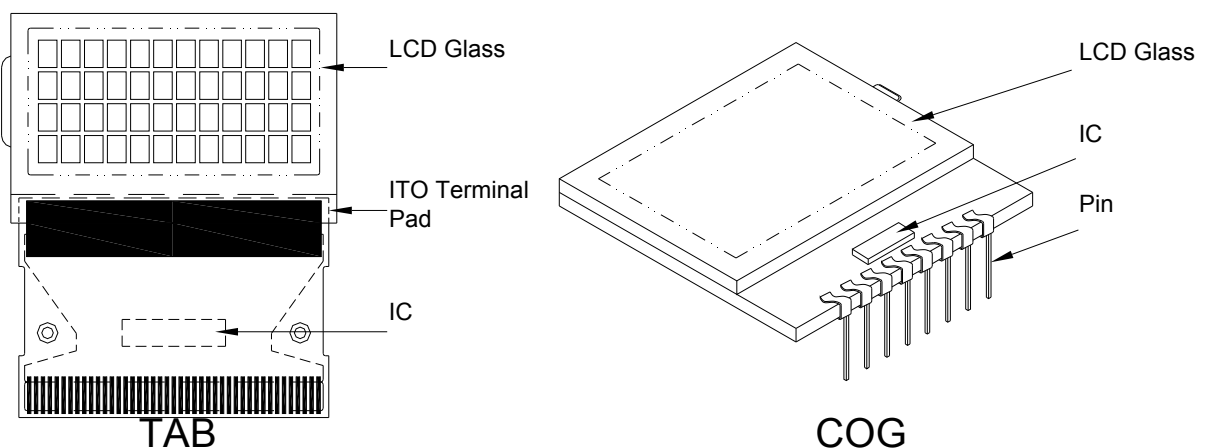

8-3. Sampling Plan and Acceptance

1. Sampling Plan

MIL - STD - 105E (||) ordinary single inspection is used.

2. Acceptance

Major defect: AQL = 0.65%

Minor defect: AQL = 1.5%

8-4. Criteria

1. COB

Defect	Inspection Item	Inspection Standards	
Major	PCB copper flakes peeling off	Any copper flake in viewing Area should be greater than 1.0mm ²	Reject
Major	Height of coating epoxy	Exceed the dimension of drawing	Reject
Major	Void or hole of coating epoxy	Expose bonding wire or IC	Reject
Major	PCB cutting defect	Exceed the dimension of drawing	Reject

2. SMT

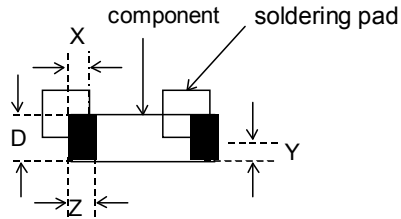
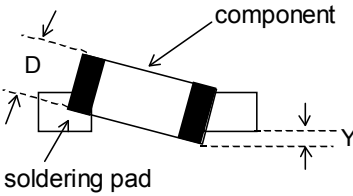
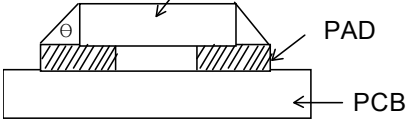
Defect	Inspection Item	Inspection Standards	
Minor	Component marking not readable		Reject
Minor	Component height	Exceed the dimension Of drawing	Reject
Major	Component solder defect (missing , extra, wrong component or wrong orientation)		Reject
Minor	Component position shift 	$X < 3/4Z$ $Y > 1/3D$	Reject Reject
Minor	Component tilt 	$Y > 1/3D$	Reject
Minor	Insufficient solder 	$\theta \leq 20^\circ$	Reject

3. Metal (Plastic) Frame

Defect	Inspection Item	Inspection Standards		
Major	Crack / breakage	Anywhere		Reject
Minor	Frame Scratch	W	L	Acceptable of Scratch
		w<0.1mm	Any	Ignore
		0.1≤w<0.2mm	L≤5.0mm	2
		0.2≤w<0.3mm	L<3.0mm	1
		w>0.3mm	Any	0
		Note : 1. Above criteria applicable to scratch lines with distance greater than 5mm. 2. Scratch on the back side of frame (not visible) can be ignored .		
Minor	Frame Dent , Prick $\Phi = \frac{L + W}{2}$			Acceptable of Dents / Pricks
		$\Phi \leq 1.0\text{mm}$		2
		$1.0 < \Phi \leq 1.5\text{mm}$		1
		$1.5\text{mm} < \Phi$		0
		Note : 1. Above criteria applicable to any two dents / pricks with distance greater than 5mm 2. Dent / prick on the back side of frame (not visible) can be ignored		
Minor	Frame Deformation	Exceed the dimension of drawing		
Minor	Metal Frame Oxidation	Any rust		

4. Flexible Film Connector (FFC)

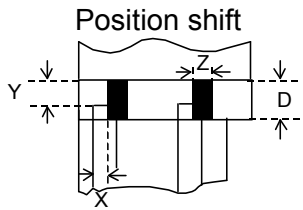
Defect	Inspection Item	Inspection Standards	
Minor	Tilted soldering	Within the angle +5°	Acceptable
Minor	Uneven solder joint /bump	Reject	
Minor	Hole $\Phi = \frac{L + W}{2}$	Expose the conductive line	Reject
		$\Phi > 1.0\text{mm}$	Reject
Minor	 <p>Position shift</p>	$Y > 1/3D$	Reject
		$X > 1/2Z$	Reject

5. Screw

Defect	Inspection Item	Inspection Standards	
Major	Screw missing/loosen		Reject
Minor	Screw oxidation	Any rust	Reject
Minor	Screw deformation	Difficult to accept screw driver	Reject

6. Heatseal 、TCP 、FPC

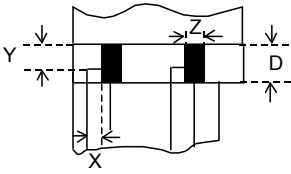
Defect	Inspection Item	Inspection Standards	
Major	Scratch expose conductive layer		Reject
Minor	HS Hole $\Phi = \frac{L+W}{2}$	$\Phi > 0.5\text{mm}$	Reject
Major	Adhesion strength	Less than the specification	Reject
Minor	Position shift 	$Y > 1/3D$	Reject
		$X > 1/2Z$	Reject
Major	Conductive line break		Reject

7. LED Backing Protective Film and Others

Defect	Inspection Item	Inspection Standards	
Minor	LED dirty, prick	Acceptable number of units	
		$\Phi \leq 0.10\text{mm}$	Ignore
		$0.10 < \Phi \leq 0.15\text{mm}$	2
		$0.15 < \Phi \leq 0.2\text{mm}$	1
		$\Phi > 0.2\text{mm}$	0
		The distance between any two spots should be $\geq 5\text{mm}$ Any spot/dot/void outside of viewing area is acceptable	
Minor	Protective film tilt	Not fully cover LCD	Reject
Major	COG coating	Not fully cover ITO circuit	Reject

8. Electric Inspection

Defect	Inspection Item	Inspection Standards	
Major	Short		Reject
Major	Open		Reject

9. Inspection Specification of LCD

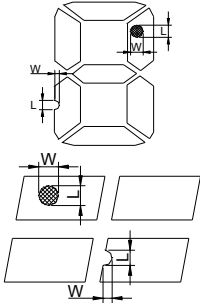
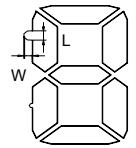
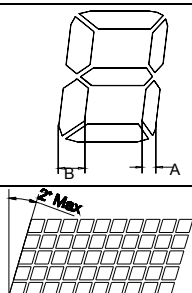
Defect	Inspect Item	Inspection Standards					
Minor	Linear Defect	* Glass Scratch * Polarizer Scratch * Fiber and Linear material	W	$W \leq 0.03$	$0.03 < W \leq 0.05$	$W > 0.05$	
			L	$L < 5$	$L < 3$	Any	
			ACC. NO.	1	1	Reject	
			Note	L is the length and W is the width of the defect			
Minor	Black Spot and Polarizer Pricked	* Foreign material between glass and polarizer or glass and glass * Polarizer hole or protuberance by external force	Φ	$\Phi \leq 0.1$	$0.1 < \Phi \leq 0.15$	$0.15 < \Phi \leq 0.2$	$\Phi > 0.2$
			ACC. NO.	3EA / 100mm ²	2	1	0
			Note	Φ is the average diameter of the defect. Distance between two defects > 10mm.			
Minor	White Spot and Bubble in polarizer	* Unobvious transparent foreign material between glass and glass or glass and polarizer * Air protuberance between polarizer and glass	Φ	$\Phi \leq 0.3$	$0.3 < \Phi \leq 0.5$	$0.5 < \Phi$	
			ACC. NO.	3EA / 100mm ²	1	0	
			Note	Φ is the average diameter of the defect. Distance between two defects > 10mm.			
Minor	Segment Defect		Φ	$\Phi \leq 0.10$	$0.10 < \Phi \leq 0.20$	$0.20 < \Phi \leq 0.25$	$\Phi > 0.25$
			ACC. NO.	3EA / 100mm ²	2	1	0
			Note	W is more than 1/2 segment width			Reject
			Note	$\Phi = \frac{L + W}{2}$ Distance between two defect is 10mm			
Minor	Protuberant Segment	 $\Phi = (L + W) / 2$	Φ	$\Phi \leq 0.10$	$0.10 < \Phi \leq 0.20$	$0.20 < \Phi \leq 0.25$	$\Phi > 0.25$
			W	Glue	$W \leq 1/2$ Seg $W \leq 0.2$	$W \leq 1/2$ Seg $W \leq 0.2$	Ignore
			ACC. NO.	3EA / 100mm ²	2	1	0
Minor	Assembly Mis-alignment		1. Segment				
			B	$B \leq 0.4\text{mm}$	$0.4 < B \leq 1.0\text{mm}$	$B > 1.0\text{mm}$	
			B-A	$B-A < 1/2B$	$B-A < 0.2$	$B-A < 0.25$	
			Judge	Acceptable	Acceptable	Acceptable	
			2. Dot Matrix				
Deformation > 2°				Reject			
Minor	Stain on LCD Panel Surface		Accept when stains can be wiped lightly with a soft cloth or a similar one. Otherwise, judged according to the above items: "Black spot" and "White Spot"				

9. RELIABILITY

No	Item	Condition	Quantity	Criteria
1	High Temperature Operating	70°C, 96Hrs	2	GB/T2423.2 -2008
2	Low Temperature Operating	-20°C, 96Hrs	2	GB/T2423.1 -2008
3	High Humidity	50°C, 90%RH, 96Hrs	2	GB/T2423.3 -2006
4	High Temperature Storage	80°C, 96Hrs	2	GB/T2423.2 -2008
5	Low Temperature Storage	-30°C, 96Hrs	2	GB/T2423.1 -2008
6	Thermal Cycling Test	-20°C, 60min~70°C, 60min, 20 cycles.	2	GB/T2423.2 2 -2012
7	Packing vibration	Frequency range:10Hz~50Hz Acceleration of gravity:5G X,Y,Z 30 min for each direction.	2	GB/T5170.1 4 -2009
8	Electrical Static Discharge	Air: ±8KV 150pF/330 Ω 5 times	2	GB/T17626. 2 -2006
		Contact: ±4KV 150pF/330 Ω 5 times		
9	Drop Test (Packaged)	Height:80 cm,1 corner, 3 edges, 6 surfaces.	2	GB/T2423.8 -1995

Note: 1) Above conditions are suitable for our company standard products.

2) For restrict products, the test conditions listed as above must be revised.

10. HANDLING PRECAUTION

(1) Mounting Method

The panel of the LCD Module consists of two thin glass plates with polarizers which easily get damaged since the Module is fixed by utilizing fitting holes in the printed circuit board. Extreme care should be taken when handling the LCD Modules.

(2) Caution of LCD handling & cleaning

When cleaning the display surface, use soft cloth with solvent (recommended below) and wipe lightly.

- Isopropyl alcohol
- Ethyl alcohol
- Trichloro trifluro thane

Do not wipe the display surface with dry or hard materials that will damage the polarizer surface.

Do not use the following solvent:

- Water
- Ketone
- Aromatics

(3) Caution against static charge

The LCD Module use C-MOS LSI drivers, so we recommend that you connect any unused input terminal to VDD or VSS, do not input any signals before power is turned on. And ground your body, Work/assembly table. And assembly equipment to protect against static electricity.

(4) Packaging

- Modules use LCD elements, and must be treated as such. Avoid intense shock and falls from a height.
- To prevent modules from degradation. Do not operate or store them exposed directly to sunshine or high temperature/humidity.

(5) Caution for operation

- It is indispensable to drive LCD's within the specified voltage limit since the higher voltage than the limit shorten LCD life. An electrochemical reaction due to direct current causes LCD deterioration, Avoid the use of direct current drive.
- Response time will be extremely delayed at lower temperature than the operating temperature range and on the other hand at higher temperature LCD's show dark color in them. However those phenomena do not mean malfunction or out of order with LCD's. Which will come back in the specified operating temperature range.
- If the display area is pushed hard during operation, some font will be abnormally displayed but it resumes normal condition after turning off once.
- A slight dew depositing on terminals is a cause for electro-chemical reaction resulting in terminal open circuit.

Usage under the relative condition of 40°C, 50%RH or less is required.

(6) Storage

In the case of storing for a long period of time (for instance.) For years) for the purpose or replacement use, The following ways are recommended.

- Storage in a polyethylene bag with sealed so as not to enter fresh air outside in it, And with no desiccant.
- Placing in a dark place where neither exposure to direct sunlight nor light is. Keeping temperature in the specified storage temperature range.
- Storing with no touch on polarizer surface by the anything else. (It is recommended to store them as they have been contained in the inner container at the time of delivery)

(7) Safety

- It is recommendable to crash damaged or unnecessary LCD into pieces and wash off liquid crystal by using solvents such as acetone and ethanol. Which should be burned up later.

When any liquid crystal leaked out of a damaged glass cell comes in contact with your hands, please wash it off well with soap and water.

(8) Other

- After the product shipped, any product quality issues must be feedback within three months, otherwise, we will not be responsible for the subsequent or consequential events.

12 PACKING INSTRUCTION

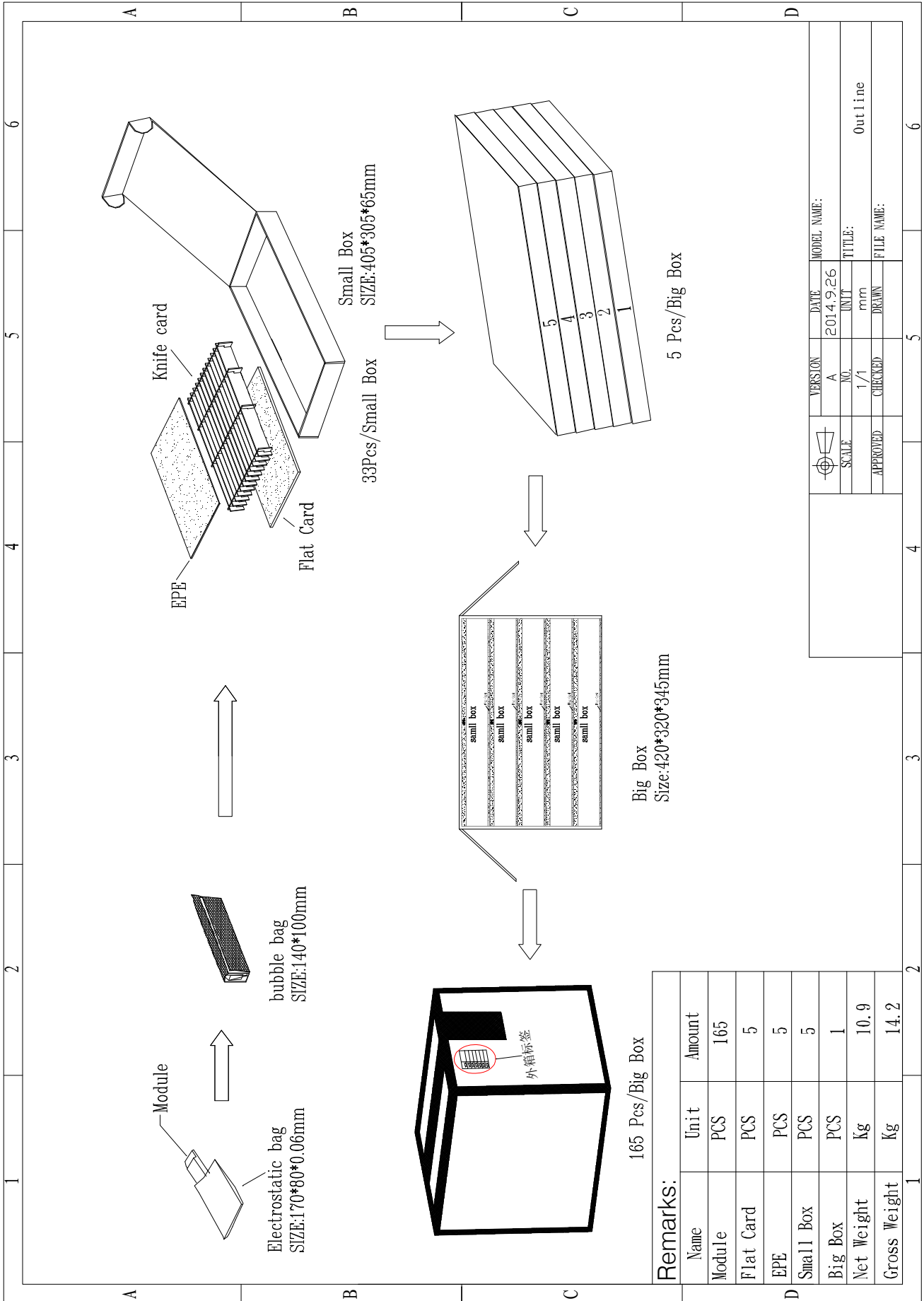

Remarks:

Name	Unit	Amount
Module	PCS	165
Flat Card	PCS	5
EPE	PCS	5
Small Box	PCS	5
Big Box	PCS	1
Net Weight	Kg	10.9
Gross Weight	Kg	14.2

VERSION	DATE	MODEL NAME:
A	2014.9.26	
NO.	UNIT	TITLE:
1/1	mm	Outline
CHECKED	DRAWN	FILE NAME: