

# DISPLAYTRONIC

*XIAMEN ZETTLER ELECTRONICS CO., LTD*

## SPECIFICATIONS FOR LIQUID CRYSTAL DISPLAY

CUSTOMER APPROVAL			
※ PART NO. : <u>AGM1232GE-NLW-BBW (DISPLAYTRONIC) VER1.0</u>			
APPROVAL		COMPANY CHOP	
CUSTOMER COMMENTS			

DISPLAYTRONIC ENGINEERING APPROVAL		
DESIGNED BY	CHECKED BY	APPROVED BY
JFM	LIU	GZH

**REVISION RECORD**

REVISION	REVISION DATE	PAGE	CONTENTS
<b>VER1.0</b>	<b>13/08-2012</b>		<b>FIRST ISSUE</b>

※ **CONTENTS**

- 1.0 GENERAL SPECIFICATION
- 2.0 ABSOLUTE MAXIMUM RATINGS
- 3.0 ELECTRICAL CHARACTERISTICS
- 4.0 OPTICAL CHARACTERISTICS
- 5.0 BLOCK DIAGRAM
- 6.0 PIN ASSIGNMENT
- 7.0 POWER SUPPLY
- 8.0 TIMING CHARACTERISTICS
- 9.0 MECHANICAL DIAGRAM
- 10.0 RELIABILITY TEST
- 11.0 INSTRUCTION DESCRIPTION
- 12.0 PRECAUTION FOR USING LCM

## 1.0 GENERAL SPECS

1. Display Format	122*32 Dot matrix
2. Power Supply	5.0V(Single power supply without DC-DC,adjustable Vop )
3. Overall Module Size	80.0mm(W) x 36.0mm(H) x max13.5mm(D)
4 Viewing Area(W*H)	60.0mm(W) x 18.0mm(H)
5 Dot Size (W*H)	0.40mm(W) x 0.45mm(H)
6 Dot Pitch (W*H)	0.44mm(W) x 0.49mm(H)
7 Viewing Direction	6:00 O'Clock
8 Driving Method	1/32 Duty,1/5 Bias
9 Controller IC	PT6520 or compatible
10 Display Mode	STN /Blue/Negative/Transmissive
11 Backlight Options	White LED/Side
12 Operating temperature	-20°C ~ 70°C
13 Storage temperature	-30°C ~ 80°C
14 RoHS	ROHS compliant

## 2.0 ABSOLUTE MAXIMUM RATINGS

Item	Symbol	Min	Typ	Max	Unit
Operating temperature	Top	-20	-	70	°C
Storage temperature	Tst	-30	-	80	°C
Input voltage	Vin	-0.3	-	Vdd+0.3	V
Supply voltage for logic	Vdd- Vss	2.4	-	7.0	V
Supply voltage for LCD drive	Vdd- V0	3.5		13.0	V

## 3.0 ELECTRICAL CHARACTERISTICS

### 3.1 Electrical Characteristics Of LCM

Item	Symbol	Condition	Min	Typ	Max	Unit
Power Supply Voltage	Vdd	25°C	4.8	5.0	5.2	V
Power Supply Current	Idd	Vdd=5.0V	--	2.0	--	mA
Input voltage (high)	Vih	Pins:(E,R/W, AØ,DB0-DB7) VDD=5V	Vdd-2.2	--	Vdd	V
Input voltage (low)	Vil		0	--	0.8	V
Recommended Driving Voltage	LC Vdd -V0	-20°C	--	--	5.0	V
		25°C	4.3	4.5	4.7	
		70°C	4.0	--	--	

### 3.2 The Characteristics Of LED Backlight

#### 3.2.1 Electrical-Optical Characteristics Of LED Backlight (Ta=25°C)

Item	Symbol	Condition	Min	Typ	Max	Unit
Forward Voltage <sup>(1)</sup>	Vf	If=30mA	2.9	3.1	3.3	V
Reverse Voltage	Vr	-	--	--	5	V
Luminance <sup>(2)</sup>	Lv	If=30mA	210	300	390	cd/m <sup>2</sup>
Uniformity <sup>(3)</sup>	Δ	(Lvmin/Lvmax)%	70%	--	--	-
Peak wave length	λ p	If=30mA	--	--	--	nm
Chroma coordinate	x	If=30mA	0.26	--	0.30	um
	y	If=30mA	0.27	--	0.31	um
Lifetime <sup>(4)</sup>	-	If=30mA	-	20000	-	Hours

NOTE:

- (1) Forward voltage means voltage applied directly to the LED, please refer to the backlight diagram.
- (2) The luminance is the average value of 5 points, The measurement instrument is BM-7 luminance colorimeter. The diameter of aperture is Φ5mm
- (3) Luminance means the backlight brightness without LCD.
- (4) Backlight lifetime means luminance value larger than half of the original after 20000 hours' continuous working.
- (5) Please apply the backlight current as the table recommend. If LCM surface luminance is acceptable, please apply the driving current as lower as possible. Any time, do not apply the driving current higher than 45mA.

#### 3.2.2 Backlight Control Circuit For LCM (1x2=2 pcs LED)

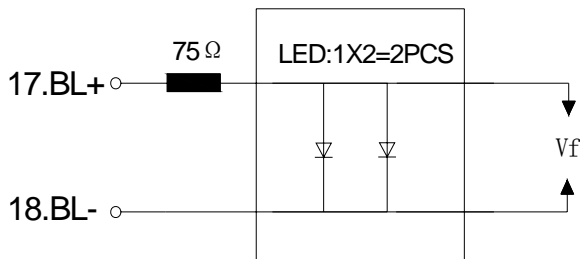

#### 3.2.3 LED Characteristics Curves (for single led)

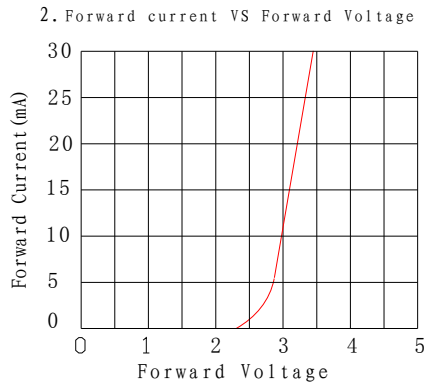
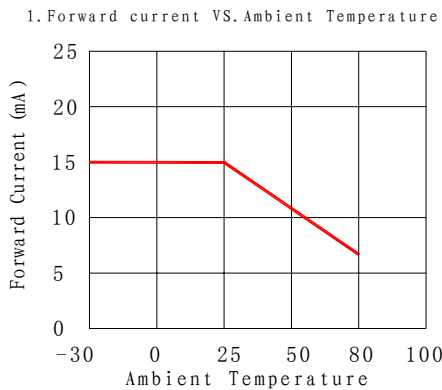

### 4.0 OPTICAL CHARACTERISTICS

Item	Symbol	Condition	Min	Typ	Max	Unit
Viewing angle (Left - right)	$\theta 2$	$Cr \geq 2.0$	-35	-	35	deg
Viewing angle (Up-down)	$\theta 1$	$Cr \geq 2.0$	-25	-	40	deg
Contrast Ratio	Cr	$\theta 1=0^\circ, \theta 2=0^\circ$	-	6	-	
Response time (rise)	Tr	$\theta 1=0^\circ, \theta 2=0^\circ$	-	180	300	ms
Response time (fall)	Tf	$\theta 1=0^\circ, \theta 2=0^\circ$	-	150	250	ms

#### (1). Definition of Optical Response Time

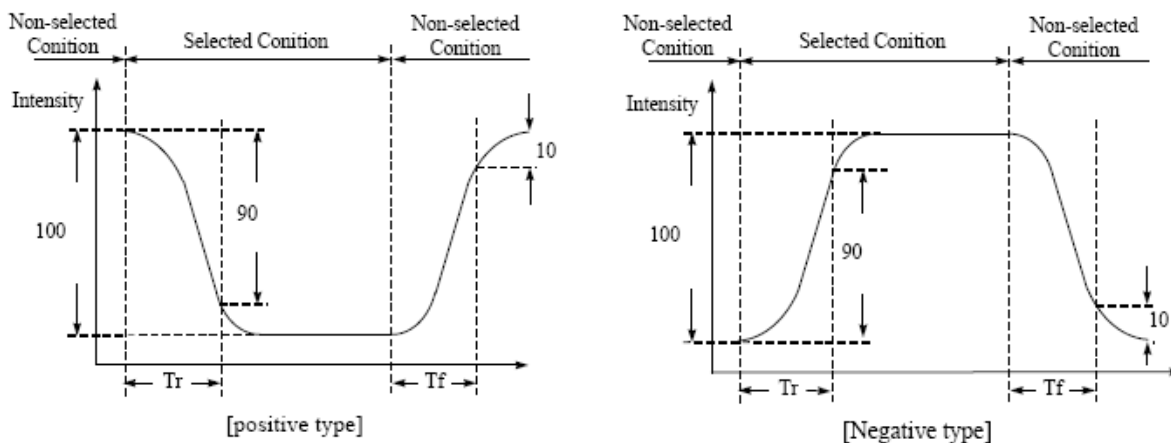

#### (2). Definition of Contrast Ratio

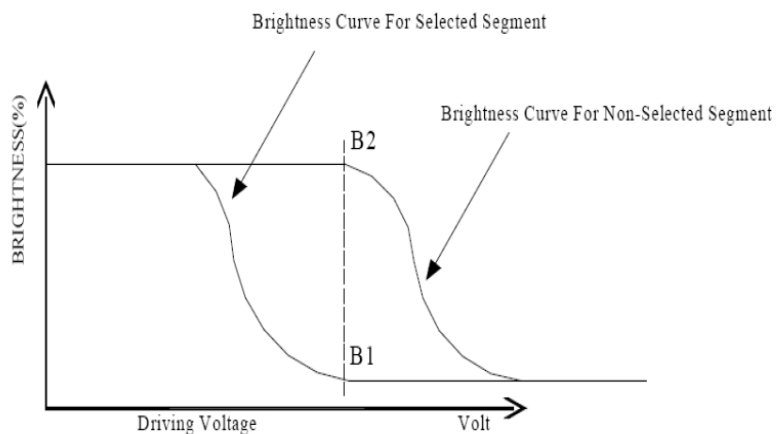

$$C_r = \frac{\text{Brightness of Non-selected Segment}(B2)}{\text{Brightness of selected Segment}(B1)}$$

**(3). Definition of Viewing Angle  $\theta_2$  and  $\theta_1$**

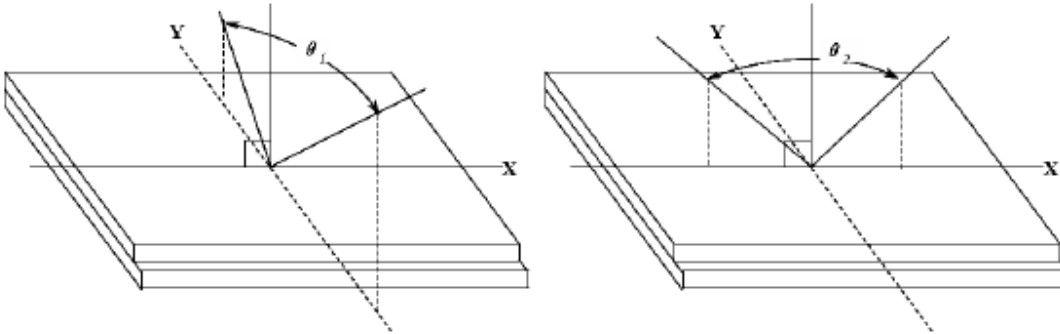

**5.0 BLOCK DIAGRAM**

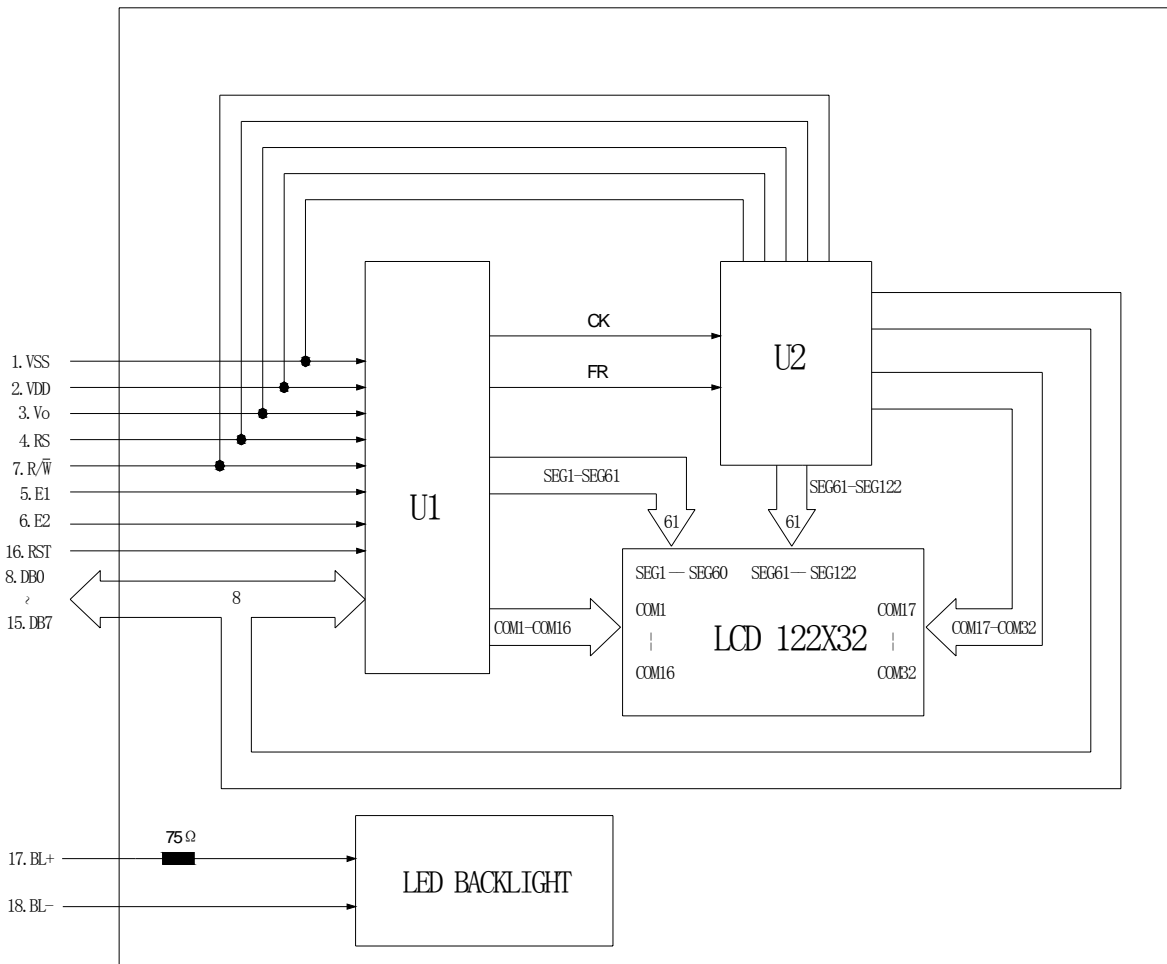

## 6.0 PIN ASSIGNMENT

Pin No.	Symbol	Function	Level
1	Vss	Ground	-
2	Vdd	Power Supply For Logic Circuit	-
3	Vo	Power Supply For LCD Driving	-
4	RS	Instruction/Data	H/L
5	E1	Enable for IC1	H/L
6	E2	Enable for IC2	H/L
7	R/W	H: Data read L: Data write	H/L
8	DB0	Data bit 0	H/L
9	DB1	Data bit 1	H/L
10	DB2	Data bit 2	H/L
11	DB3	Data bit 3	H/L
12	DB4	Data bit 4	H/L
13	DB5	Data bit 5	H/L
14	DB6	Data bit 6	H/L
15	DB7	Data bit 7	H/L
16	RST	Reset	
17	BL+	Power Supply for LED+	-
18	BL-	Power Supply for LED-	-

## 7.0 POWER SUPPLR

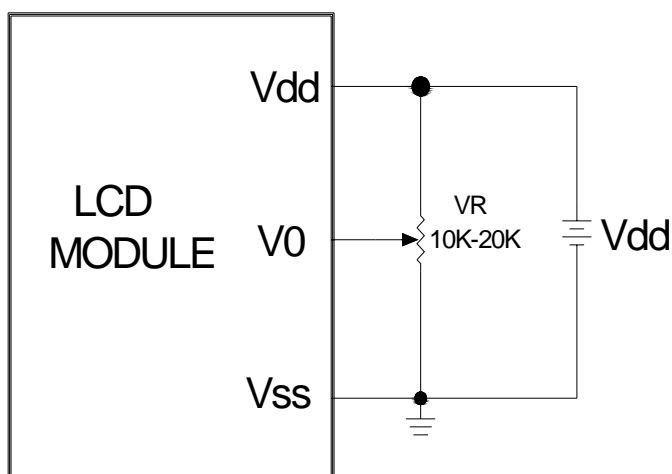



### 8.0 TIMING CHARACTERISTIC

#### System Bus Read/Write II (68-family MPU)

T<sub>a</sub> = -210 to 75°C, V<sub>SS</sub> = -5.0V ±10%

Parameter	Symbol	Signal	Condition	Min	Typ	Max	Unit
System cycle time	t <sub>CYC6</sub> <sup>1</sup>	A0, $\overline{CS}$	CL = 100 pF	1000	—	—	ns
Address setup time	t <sub>AW6</sub>	R/ $\overline{W}$		20	—	—	ns
Address hold time	t <sub>AH6</sub>			10	—	—	ns
Data setup time	t <sub>DS6</sub>	D0 – D7		80	—	—	ns
Data hold time	t <sub>DH6</sub>			10	—	—	ns
Output disable time	t <sub>OH6</sub>			10	—	60	ns
Access time	t <sub>ACC6</sub>	E		—	—	90	ns
Enable pulse width: Read	t <sub>EW</sub>		100	—	—	ns	
Enable pulse width: Write		80	—	—	ns		

- 1 t<sub>CYC6</sub> indicates the cycle time during which  $\overline{CS} \cdot E = "H"$ . It does not mean the cycle time of signal E.
- 2 Each of the values where V<sub>SS</sub> = -3.0V is about 200% of that where V<sub>SS</sub> = -5.0V (i.e., the listed value).
- 3 The rise or fall time of input signals should be less than 15 ns.

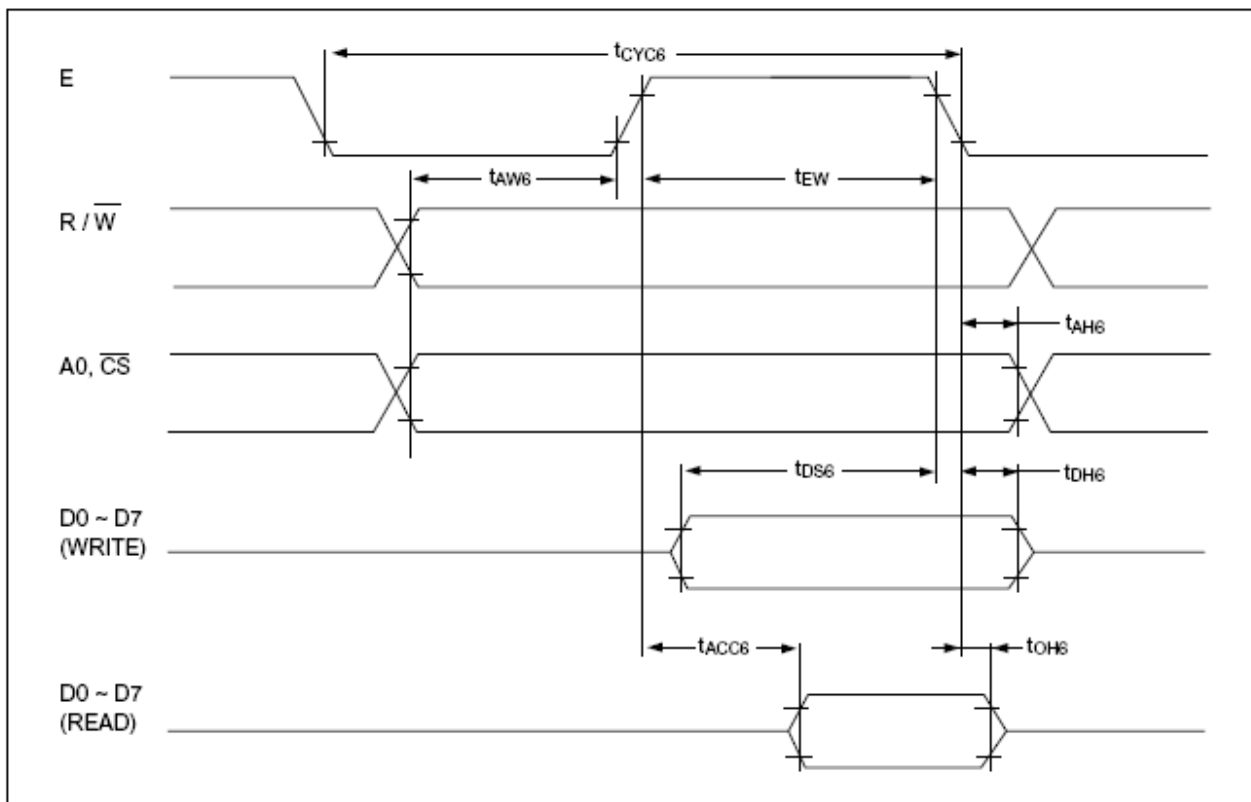

System bus read/write II (68-family MPU)

For more details, please refer to IC specification.

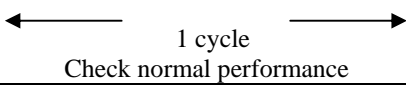

**10.0RELIABILITY TEST**

NO	Test Item	Description	Test Condition	Remark	
1	Environmental Test	High temperature storage	Applying the high storage temperature Under normal humidity for a long time Check normal performance	80 °C 96hrs	
2		Low temperature storage	Applying the low storage temperature Under normal humidity for a long time Check normal performance	-30°C 96hrs	
3		High temperature Operation	Apply the electric stress(Voltage and current) Under high temperature for a long time	70 °C 96hrs	Note1
4		Low temperature Operation	Apply the electric stress Under low temperature for a long time	-20°C 96hrs	Note1 Note2
5		High temperature/High Humidity Storage	Apply high temperature and high humidity storage for a long time	90% RH 40°C 96hrs	Note2
6		Temperature Cycle	Apply the low and high temperature cycle -30°C <> 25°C <> 80°C <> 25°C 30min 10min 30min 10min  Check normal performance	-30°C/80°C 10 cycle	
7	Mechanical Test	Vibration test(Package state)	Applying vibration to product check normal performance	Freq:10~55~10Hz Amplitude:0.75mm 1cycle time:1min X.Y.Z every direction for 15 cycles	
8		Shock test(package state)	Applying shock to product check normal performance	Drop them through 70cm height to strike horizontal plane	
9	Other				

Remark

Note1:Normal operations condition (25°C±5°C).

Note2:Pay attention to keep dewdrops from the module during this test.

### 11.0 DISPLAY CONTROL INSTRUCTION

The display control instructions control the internal state of the PT6520-HD. Instructions are received from MPU to PT6520-HD for the display control.

	Command	Code											Function
		A0	RD	WR	D7	D6	D5	D4	D3	D2	D1	D0	
(1)	Display ON/OFF	0	1	0	1	0	1	0	1	1	1	0/1	Turns all display on or off, independently of display RAM data or internal status. 1: ON 0: OFF (Power-saving mode with static drive on)*
(2)	Display Start Line	0	1	0	1	1	0	Display Start Address (0 – 31)				0	Specifies RAM line corresponding to uppermost line (COM0) of display.
(3)	Set Page Address	0	1	0	1	0	1	1	1	0	Page (0-3)		Sets display RAM page in page address register.
(4)	Set Column (Segment) Address	0	1	0	0	Column Address (0-79)						0	Sets display RAM column address in column address register.
(5)	Read Status	0	0	1	Busy	ADC	ON/OFF	RESET	0	0	0	0	Reads the following status: BUSY 1: Internal operation 0: Ready ADC 1: CW output (forward) 0: CCW output (reverse) ON/OFF 1: Display off 0: Display on RESET 1: Being reset 0: Normal
(6)	Write Display Data	1	1	0					Write Data				
(7)	Read Display Data	1	0	1	Read Data						0	Reads data from display RAM onto data bus.	
(8)	Select ADC	0	1	0	1	0	1	0	0	0	0	0/1	Used to invert relationship of assignment between display RAM column addresses and segment driver outputs. 0: CW output (forward) 1: CCW output (reverse)
(9)	Static Drive ON/OFF	0	1	0	1	0	1	0	0	1	0	0/1	Selects normal display or static driving operation. 1: Static drive (power-saving mode) 0: Normal driving
(10)	Select Duty	0	1	0	1	0	1	0	1	0	0	0/1	Selects LCD cell driving duty 1: 1/32 0: 1/16
(11)	Read Modify Write	0	1	0	1	1	1	0	0	0	0	0	Increments column address counter by 1 when display data is written. (This is not done when data is read.)
(12)	End	0	1	0	1	1	1	0	1	1	1	0	Clears read modify write mode.
(13)	Reset	0	1	0	1	1	1	0	0	0	1	0	Sets display start line register on the first line. Also sets column address counter and page address counter to 0.

## 12.0 PRECAUTION FOR USING LCM

1. When design the product with this LCD Module, make sure the viewing angle matches to its purpose of usage.
2. As LCD panel is made of glass substrate, Dropping the LCD module or banging it against hard objects may cause cracking or fragmentation. Especially at corners and edges.
3. Although the polarizer of this LCD Module has the anti-glare coating, always be careful not to scratch its surface. Use of a plastic cover is recommended to protect the surface of polarizer.
4. If the LCD module is stored at below specified temperature, the LC material may freeze and be deteriorated. If it is stored at above specified temperature, the molecular orientation of the LC material may change to Liquid state and it may not revert to its original state. Excessive temperature and humidity could cause polarizer peel off or bubble. Therefore, the LCD module should always be stored within specified temperature range.
5. Saliva or water droplets must be wiped off immediately as those may leave stains or cause color changes if remained for a long time. Water vapor will cause corrosion of ITO electrodes.
6. If the surface of LCD panel needs to be cleaned, wipe it swiftly with cotton or other soft cloth. If it is not still clean enough, blow a breath on the surface and wipe again.
7. The module should be driven according to the specified ratings to avoid malfunction and permanent damage. Applying DC voltage cause a rapid deterioration of LC material. Make sure to apply alternating waveform by continuous application of the M signal. Especially the power ON/OFF sequence should be kept to avoid latch-up of driver LSIs and DC charge up to LCD panel.
8. Mechanical Considerations
  - a) LCM are assembled and adjusted with a high degree of precision. Avoid excessive shocks and do not make any alterations or modifications. The following should be noted.
  - b) Do not tamper in any way with the tabs on the metal frame.
  - c) Do not modify the PCB by drilling extra holes, changing its outline, moving its components or modifying its pattern.
  - d) Do not touch the elastomer connector; especially insert a backlight panel (for example, EL).
  - e) When mounting a LCM makes sure that the PCB is not under any stress such as bending or twisting. Elastomer contacts are very delicate and missing pixels could result from slight dislocation of any of the elements.
  - f) Avoid pressing on the metal bezel, otherwise the elastomer connector could be deformed and lose contact, resulting in missing pixels.
9. Static Electricity
  - a) Operator

**Wear the electrostatics shielded clothes because human body may be statically charged if not wear shielded clothes. Never touch any of the conductive parts such as the LSI pads; the copper leads on the PCB and the interface terminals with any parts of the human body.**

- b) Equipment

There is a possibility that the static electricity is charged to the equipment, which has a function of peeling or friction action (ex: conveyer, soldering iron, working table). Earth the equipment through proper resistance (electrostatic earth:  $1 \times 10^8$  ohm).

Only properly grounded soldering irons should be used.

If an electric screwdriver is used, it should be well grounded and shielded from commutator sparks.

The normal static prevention measures should be observed for work clothes and working benches; for the latter conductive (rubber) mat is recommended.

- c) Floor

**Floor is the important part to drain static electricity, which is generated by operators or equipment.**

There is a possibility that charged static electricity is not properly drained in case of insulating floor. Set the electrostatic earth (electrostatic earth:  $1 \times 10^8$  ohm).

- d) Humidity

Proper humidity helps in reducing the chance of generating electrostatic charges. Humidity should be kept over 50%RH.

- e) Transportation/storage

**The storage materials also need to be anti-static treated because there is a possibility that the human body or storage materials such as containers may be statically charged by friction or peeling.**

The modules should be kept in antistatic bags or other containers resistant to static for storage.

- f) Soldering

Solder only to the I/O terminals. Use only soldering irons with proper grounding and no leakage.

Soldering temperature :  $280^{\circ} \text{C} \pm 10^{\circ} \text{C}$

Soldering time: 3 to 4 sec.

Use eutectic solder with resin flux fill.

If flux is used, the LCD surface should be covered to avoid flux spatters. Flux residue should be removed afterwards.

g) Others

**The laminator (protective film) is attached on the surface of LCD panel to prevent it from scratches or stains. It should be peeled off slowly using static eliminator.**

Static eliminator should also be installed to the workbench to prevent LCD module from static charge.

10. Operation

- a) Driving voltage should be kept within specified range; excess voltage shortens display life.
  - b) Response time increases with decrease in temperature.
  - c) Display may turn black or dark blue at temperatures above its operational range; this is (however not pressing on the viewing area) may cause the segments to appear "fractured".
  - d) Mechanical disturbance during operation (such as pressing on the viewing area) may cause the segments to appear "fractured".
11. If any fluid leaks out of a damaged glass cell, wash off any human part that comes into contact with soap and water. The toxicity is extremely low but caution should be exercised at all the time.
12. Disassembling the LCD module can cause permanent damage and it should be strictly avoided.
13. LCD retains the display pattern when it is applied for long time (Image retention). To prevent image retention, do not apply the fixed pattern for a long time. Image retention is not a deterioration of LCD. It will be removed after display pattern is changed.
14. Do not use any materials, which emit gas from epoxy resin (hardener for amine) and silicone adhesive agent (dealcohol or deoxym) to prevent discoloration of polarizer due to gas.
15. Avoid the exposure of the module to the direct sunlight or strong ultraviolet light for a long time.