

# TFT-LCD Module Specification

**Module NO.:** TST043WQZO-06C

**Version:** V1.0

APPROVAL FOR SPECIFICATION

APPROVAL FOR SAMPLE

For Customer' s Acceptance:	
Approved by	Comment

Team Source Display:		
Presented by	Reviewed by	Organized by

Version No.	Date	Content	Remark
V1.0	2017-6-32	Initial Release	

**CONTENTS**

**1 GENERAL CHARACTERISTICS..... - 3 -**

**2 PRODUCT DRAWINGS..... - 4 -**

**3 INTERFACE DESCRIPTION..... - 5 -**

    3.1 LCM INTERFACE DESCRIPTION..... - 5 -

    3.2 CTP INTERFACE DESCRIPTION..... - 6 -

**4 RGB TIMING CHARACTERISTICS..... - 6 -**

**5 ABSOLUTE MAXIMUM RATINGS..... - 7 -**

**6 ELECTRICAL CHARACTERISTICS..... - 7 -**

**7 BACKLIGHT CHARACTERISTICS..... - 7 -**

**8 LCD OPTICAL SPECIFICATIONS..... - 8 -**

**9 CAPACITIVE TOUCH PANEL SPECIFICATIONS..... - 10 -**

    9.1 MECHANICAL CHARACTERISTICS..... - 10 -

    9.2 ELECTRICAL CHARACTERISTICS..... - 10 -

    9.3 INTERFACE TIMING CHARACTERISTICS..... - 11 -

**10 RELIABILITY TEST..... - 11 -**

**11 INSPECTION STANDARDS..... - 12 -**

    11.1 VISUAL INSPECTION CRITERION IN COSMETIC..... - 12 -

        11.1.1 Glass defect..... - 12 -

        11.1.2 LCM appearance defect..... - 12 -

        11.1.3 FPC..... - 13 -

        11.1.4 Black tape..... - 13 -

        11.1.5 Silicon..... - 13 -

        11.1.6 Touch Panel..... - 13 -

    11.2 VISUAL INSPECTION CRITERION IN ELECTRICAL DISPLAY..... - 14 -

    11.3 OTHERS..... - 14 -

**12 SUGGESTIONS FOR USING LCD MODULES..... - 15 -**

    12.1 HANDLING OF LCM..... - 15 -

    12.2 STORAGE..... - 15 -

## 1 General Characteristics

ITEM	Specification	Unit
LCD Type	a-Si TFT, Transmissive, Normally white, TN	-
LCD Size	4.3	inch
Resolution (W x H)	480(RGB) × 272	pixel
CTP+LCM size	123.04(H) x 84.46(V) x 4.58(T)	mm
LCM size	105.5(H) x 67.2(V) x 3.0(T)	mm
Active Area	95.04 (H) x 53.86 V)	mm
Dot Pitch	0.198(H)x0.198(V)	mm
Viewing Direction	12 o'clock	-
Gray Scale Inversion Direction	6 o'clock	-
Viewing Angle	Top:55, Bottom:45; Left/ Right:65	deg.
Color Depth	16.7M	-
Pixel Arrangement	RGB-stripe	-
Backlight Type	7 LED, 20mA	-
Surface Luminance	340	cd/m <sup>2</sup>
Surface Treatment	Anti-Glare	-
Interface Type	TTL(RGB-24bit)	-
Input Voltage	3.3	V
With/Without TP	With CTP(FT5336)	-
Weight	TBD	g

**Note 1: RoHS compliant**

**Note 2: LCM weight tolerance: ± 5%.**



### 3 Interface description

#### 3.1 LCM interface description

PIN NO.	Symbol	description
1	VLED-	Backlight K Cathode input pin.
2	VLED+	Backlight A Anode input pin.
3	GND	System Ground. (0V)
4	VDD	Power supply +3.3V
5~12	R0~R7	Red Data BUS
13~20	G0~G7	Green Data BUS
21~28	B0~B7	Blue Data BUS
29	GND	System Ground. (0V)
30	DCLK	Clock for input data. Data latched at rising/falling edge of this signal. Default is falling edge.
31	STBYB	Standby mode control. (Normally pull high) STBYB="L", enter standby mode for power saving. Timing controller and source driver will turn off, all outputs are Hi-Z. STBYB="H", normal operation.
32	HS	Horizontal sync input in digital parallel RGB. Negative polarity.
33	VS	Vertical sync input in digital parallel RGB. Negative polarity.
34	DE	Input data enable control. When DE mode, active High to enable data input. (Normally pull low)
35	NC	
36	GND	System Ground. (0V)
37	XR/X+	NC
38	YD/Y-	NC
39	XL/X-	NC
40	YU/Y+	NC

### 3.2 CTP interface description

PIN NO.	Symbol	description
1	NC	
2	NC	
3	RST	External Reset, Low is active
4	GND	Ground. (0V)
5	INT	Interrupt request to the host
6	SDA	I2C data input and output
7	SCL	I2C clock input
8	GND	Ground. (0V)
9	GND	Ground. (0V)
10	VDD	Power supply +3.3V

## 4 RGB Timing Characteristics

DE Mode Timing Diagram

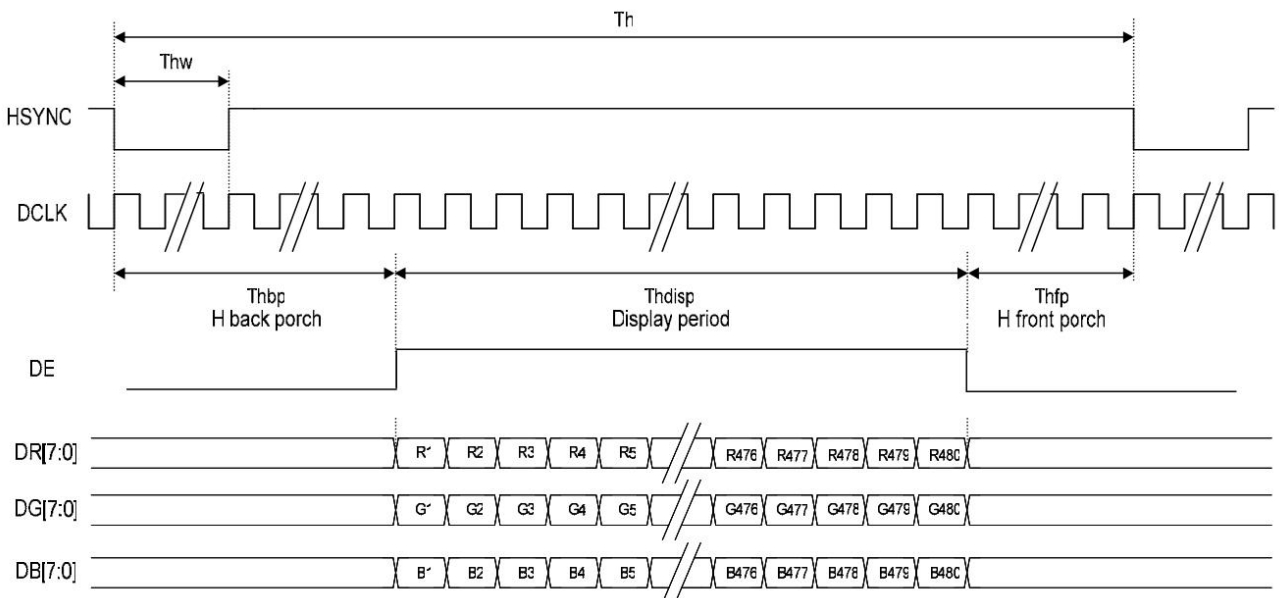

Horizontal Input Timing

Parameter	Symbol	min	Typ.	max	Unit
Horizontal display area	tHD	-	480	-	CLKIN
CLKIN frequency	f <sub>clk</sub>	5	9	12	MHz
1 Horizontal line period	t <sub>H</sub>	490	531	605	CLKIN
HSD pulse width	t <sub>HPW</sub>	1	-	-	
HSD back porch	t <sub>HBP</sub>	8	43	-	
HSD front porch	t <sub>HFP</sub>	2	8	-	

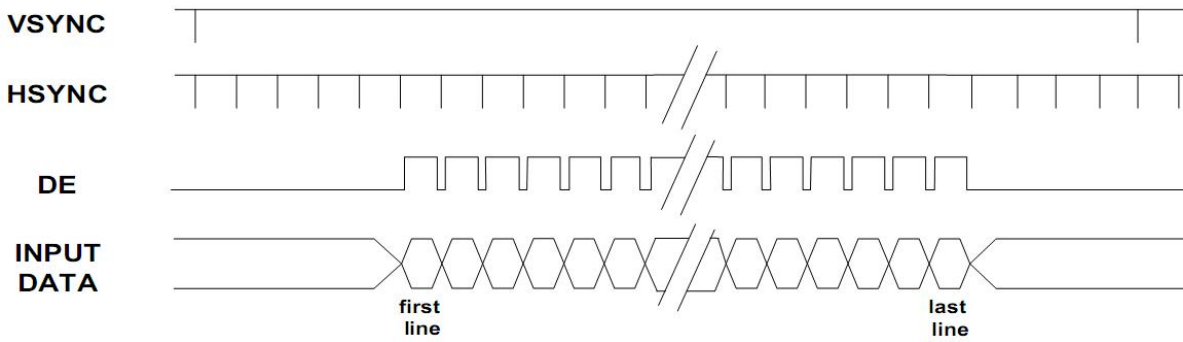

Vertical Input Timing

Parameter	Symbol	min	Typ.	max	Unit
Vertical display area	$t_{VD}$	-	272	-	HSD
VSD period time	$t_v$	275	288	335	
VSD pulse width	$T_{VPW}$	1	10	-	
VSD back porch	$t_{VBP}$	2	12	-	
VSD front porch	$t_{VFP}$	1	4	-	

## 5 Absolute Maximum Ratings

PARAMETER	SYMBOL	MIN	MAX	UNIT
Supply Voltage (Analog)	VDD~GND	-0.3	4.5	V
Logic signal voltage(I/O)	IOVDD~GND	-0.3	4.5	V
Operating Temperature	TOP	-20	70	° C
Storage Temperature	TST	-30	80	° C
Humidity	RH	-	90%(Max 60° C)	RH

## 6 Electrical Characteristics

PARAMETER	SYMBOL	MIN	TYP	MAX	UNIT
Analog operating voltage	VDD	3	3.3	3.6	V
Logic operating voltage	IOVDD	1.65	1.8	VDD	V
Input Current	IDD	-	TBD	-	mA
Input Voltage 'H' level	VIH	0.7IOVCC	-	IOVCC	V
Input Voltage 'L' level	VIL	GND	-	0.3IOVCC	
Output Voltage 'H' level	VOH	0.8IOVCC	-	IOVCC	
Output Voltage 'L' level	VOL	GND	-	0.2IOVCC	

## 7 Backlight Characteristics

ITEM	SYMBOL	MIN	TYP	MAX	UNIT
Voltage for LED backlight	$V_f$	-	24.8	25.6	V
Current for LED backlight	$I_f$	-	30	40	mA
Power consumption	Wbl	-	744	1024	mW
Uniformity	Avg	80	-	-	%
LED Life Time	-	30000	40000	-	Hrs

Note:

1. The LED life time is defined as the module brightness decrease to 50% original brightness at Ta=25°C, 60%RH ±5 %.
2. The life time of LED will be reduced if LED is driven by high current, high ambient temperature and humidity conditions.
3. Typical operating life time is an estimated data.
4. Permanent damage to the device may occur if maximum values are exceeded or reverse voltage is loaded .Functional operation should be restricted to the conditions described under normal operating conditions.

## 8 LCD Optical specifications

Item	Symbol	Condition	Specification			Unit	Remark
			Min	Typ	Max		
Response time (By Quick)	Tr+Tf	$\theta = 0^\circ$	-	30	-	ms	Note 5
Contrast ratio	CR	$\theta = 0^\circ$	250	350	-		Note 2,6
Viewing angle	Top	$CR \geq 10$	-	55	-	Deg.	Note 2,6,7
	Bottom	$CR \geq 10$	-	45	-		
	Left	$CR \geq 10$	-	65	-		
	Right	$CR \geq 10$	-	65	-		
Color Filter Chromacity with C light	Wx	$\theta = 0^\circ$	0.282	0.302	0.322		Note 3
	Wy		0.318	0.338	0.358		
	Rx		0.586	0.606	0.626		
	Ry		0.305	0.325	0.345		
	Gx		0.283	0.303	0.323		
	Gy		0.547	0.567	0.587		
	Bx		0.127	0.147	0.167		
	By		0.121	0.161	0.181		
NTSC			-	50%	-		Note 3
Transmittance	Trans		-	5.9%	-		Note 4

Note 1: Ambient temperature = 25°C.

Note 2: To be measured with a viewing cone of 2°by Topcon luminance meter BM-5A.

Note 3: To be measured with Otsuta chromaticity meter LCF-2100M, CF only measure under C light simulation.

Note 4: shipping status is cell without polarizer. Transmittance of Specification is cell with polarizer.  
The tolerance of Transmittance is ±10%.

Note 5: Definition of response time:

The output signals of TRD-100 are measured when the input signals are changed to “White” (falling time) and from “White” to “Black” (rising time), respectively. The interval is between the 10% and 90% of amplitudes. Refer to figure as below.



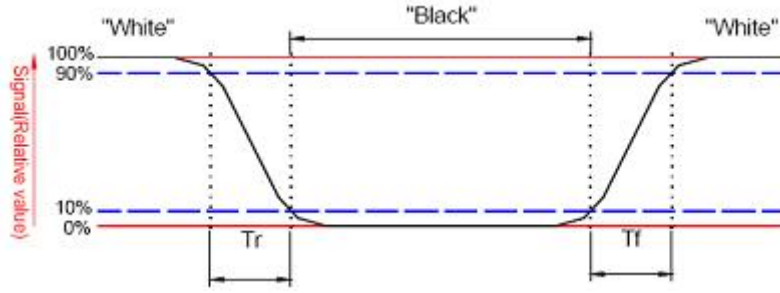

Note 6: Definition of contrast ratio:

Contrast ratio is calculated by the following formula.

$$\text{Contrast ratio (CR)} = \frac{\text{Brightness on the "white" state}}{\text{Brightness on the "black" state}}$$

Note 7: Definition of viewing angle

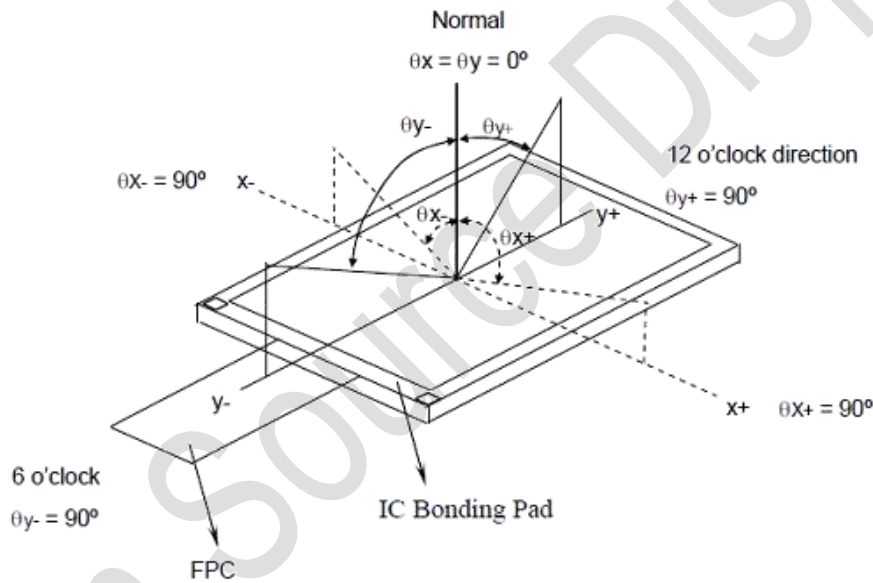

Note 8: Optical characteristic measurement setup.

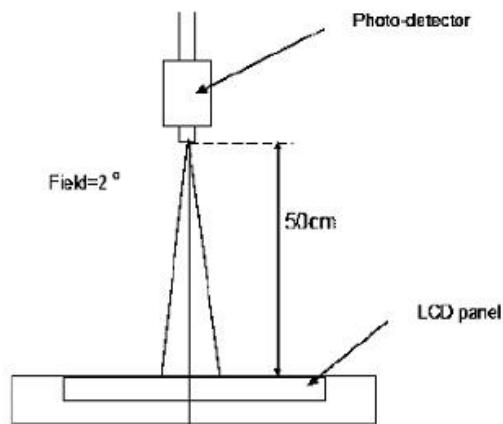

Note 9:

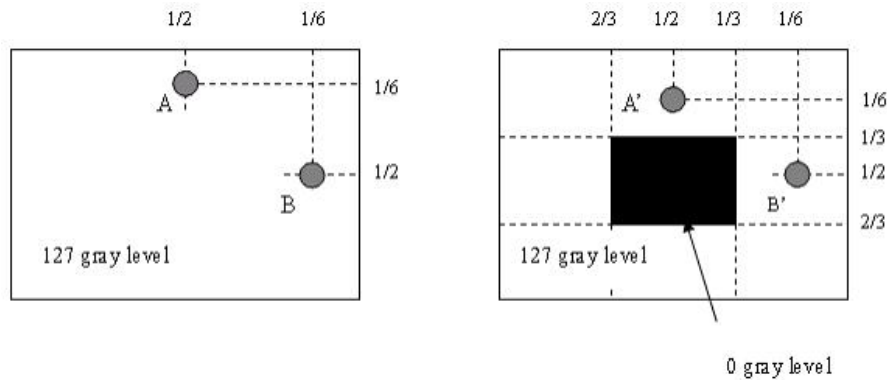

$|LA-LA'| / LA \times 100\% = 2\% \text{ max.}$ , LA and LA' are brightness at location A and A'.

$|LB-LB'| / LB \times 100\% = 2\% \text{ max.}$ , LB and LB' are brightness at location B and B'.

## 9 Capacitive Touch Panel specifications

### 9.1 Mechanical characteristics

DESCRIPTION	INL SPECIFICATION	REMARK
Touch Panel Size	4.3	
Outline Dimension (OD)	123.04(H) x 84.46(V) mm	Cover Lens Outline
Product Thickness	1.675mm(max)	With FPC and frame D.S.T
Glass Thickness	0.7mm	
Ink View Area	97.7x56.44mm	
Input Method	5 Fingers	
Activation Force	Touch	
Surface Hardness	$\geq 6H$	

### 9.2 Electrical characteristics

DESCRIPTION	SPECIFICATION	
Operating Voltage	DC 2.8~3.3V	
Power Consumption (IDD)	Active Mode	12~4.5mA
	Sleep Mode	TBD
Interface	I <sup>2</sup> C	
Controller IC	FT5336	
I <sup>2</sup> C address	0x70	
Resolution	480*272	

### 9.3 Interface timing characteristics

PARAMETER	MIN	MAX	UNIT
SCL Frequency	-	400K	Hz
Bus Free Time Between a STOP and START Condition	1.3	-	uS
Hold Time (repeated) START Condition	0.6	-	uS
Data Setup Time	100	-	nS
Setup Time for Repeated START Condition	0.6	-	uS
Setup Time for STOP Condition	0.6	-	uS

## 10 RELIABILITY TEST

NO.	TEST ITEM	TEST CONDITION	INSPECTION AFTER TEST
1	High Temperature Storage	80±2°C/96 hours	Inspection after 2~4 hours storage at room temperature and humidity. The condensation is not accepted. The sample shall be free from defects:  1. Air bubble in the LCD 2. Seal leak 3. Non-display 4. Missing segments 5. Glass crack
2	Low Temperature Storage	-30±2°C/96 hours	
3	High Temperature Operating	70±2°C/96 hours	
4	Low Temperature Operating	-20±2°C/96 hours	
5	Temperature Cycle	-30±2°C ~ 25~ 80± 2°C × 10 cycles (30 min.) (5min.) (30min.)	
6	Damp Proof Test	60°C ±5°C × 90%RH/96 hours	
7	Vibration Test	Frequency 10Hz~55Hz Stroke: 1.5mm Sweep: 10Hz~150 Hz~10Hz 2 hours For each direction of X, Y, Z	
8	Shock Test	Half-sine, wave, 300m/s	
9	Packing Drop Test	Height: 80 cm 1 corner, concrete floor	
10	Electrostatic Discharge Test	C=150pF, R=330 Ω Air: ±8KV 150pF/330Ω 30 times Contact: ±4KV,20 times	

## 11 Inspection standards

### 11.1 Visual inspection criterion in cosmetic

#### 11.1.1 Glass defect

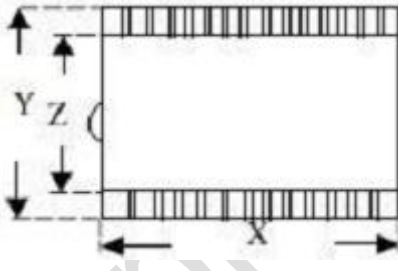
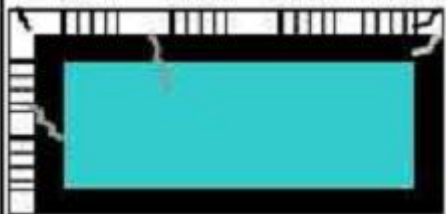
NO.	Defect	Criteria	Remark
1	Dimension(Minor)	By engineering diagram	
2	Cracks(Major)	Extensive crack [Reject]	

#### 11.1.2 LCM appearance defect

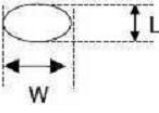
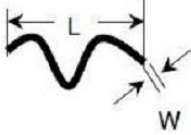
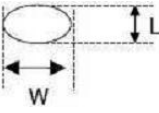
NO.	Defect	Criteria		Remark
		Spec	Permissible Qty	
1	Round type(Minor)	$\phi \leq 0.1\text{mm}$	Disregard	1. $\phi = (W+L)/2$ , L:Length,W=Width 2.Disregard if out of A.A 
		$0.1\text{mm} < \phi \leq 0.2\text{mm}$	2	
		$\phi > 0.2\text{mm}$	0	
2	Line type(Minor)	$W \leq 0.03\text{mm}$	Disregard	1. L:Length,W=Width 2.Disregard if out of A.A 
		$L \leq 3.0\text{mm}$ and $0.03\text{mm} < W \leq 0.05\text{mm}$	2	
		$L \leq 3.0\text{mm}$ and $0.05\text{mm} < W \leq 0.1\text{mm}$	1	
		$W > 0.10\text{mm}$ or $L > 3.0\text{mm}$	0	
3	Polarizer dent(Minor)	$\phi \leq 0.2\text{mm}$	Disregard	1. $\phi = (W+L)/2$ , L:Length,W=Width 2.Disregard if out of A.A 
		$0.2\text{mm} < \phi \leq 0.3\text{mm}$	2	
		$0.3\text{mm} < \phi \leq 0.5\text{mm}$	1	
		$\phi > 0.5\text{mm}$	0	

### 11.1.3 FPC

NO.	Defect	Criteria	Remark
1	Copper peeling(Minor)	Copper peeling [Reject]	
2	Damaged	Damaged[Reject]	

### 11.1.4 Black tape

NO.	Defect	Criteria	Remark
1	Shift(Minor)	IC exposed [Reject]	
2	No black tape(Minor)	No black tape [Reject]	

### 11.1.5 Silicon

NO.	Defect	Criteria	Remark
1	Amount of silicon (Minor)	ITO exposed [Reject]	

### 11.1.6 Touch Panel

Defect	Criteria	Remark
TP shift	Click on the TP, the distance between the show position and click position>1.5mm [Reject]	

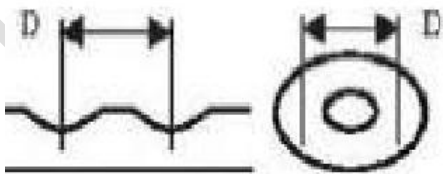
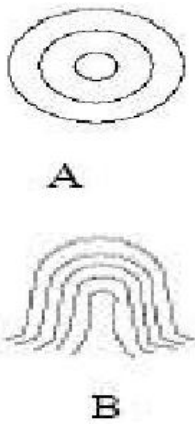
TP Circle, Dent Dot, Bubble MI	Size(mm)	Accessible QTY	
	D ≤ 0.20	Access	
	0.2 < D ≤ 0.3	2	
	0.3 < D ≤ 0.5	1	
	D > 0.5	0	
TP Ripple MI	1.(Figure A): Ripple D>5mm [Reject] 2.(Figure B): Ripple area<1/7 TP area and not impact fonts display effect [Access]		
Remark: Tear up the protective film to inspect. The distance of two dirt must>10mm; The white dot found in manufacture is conformity to 0.1mm, if >0.1mm [Reject]			

### 11.2 Visual inspection criterion in electrical display

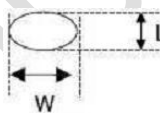
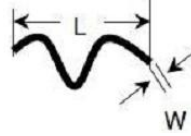
NO.	Defect	Criteria		Remark
		Spec.	Permissible Qty	
1	No display (Major)	Not allowed		
2	Missing line (Major)	Not allowed		
3	Darker or lighter Line (Major)	Not allowed		
4	Weak line(Major)	By limited sample		
5	Bright / Dark point (Minor)	Bright point	1	1:1 sub-pixel: 1R or 1G or 1B 2:Point defect area 1/2 sub pixel.
		Dark point	2	
6	Round type (Minor)	$\phi \leq 0.1\text{mm}$	Disregard	1. $\phi = (W+L)/2$ , L:Length,W=Width 2.Disregard if out of A.A 
		$0.1 < \phi \leq 0.2$	3	
		$\phi > 0.2\text{mm}$	0	
	Line type (Minor)	$W \leq 0.03\text{mm}$	Disregard	1. L:Length,W=Width 2.Disregard if out of A.A 
		$L \leq 3.0\text{mm}$ and $0.03\text{mm} < W \leq 0.05\text{mm}$	2	
		$L \leq 3.0\text{mm}$ and $0.05\text{mm} < W \leq 0.1\text{mm}$	1	
		$W > 0.10\text{mm}$ or $L > 3.0\text{mm}$	0	
	Mura (Minor)	By 5% ND filter invisible		

### 11.3 Others

1. Issues that are not defined in this document shall be discussed and agreed with both parties. (Customer and supplier)
2. Unless otherwise agreed upon in writing, the criteria shall be applied to both parties. (Customer and supplier)

## 12 Suggestions for using LCD modules

### 12.1 Handling of LCM

1. The LCD screen is made of glass. Don't give excessive external shock, or drop from a high place.
2. If the LCD screen is damaged and the liquid crystal leaks out, do not lick and swallow. When the liquid is attach to your hand, skin, cloth etc, wash it off by using soap and water thoroughly and immediately.
3. Don't apply excessive force on the surface of the LCM.
4. If the surface is contaminated, clean it with soft cloth. If the LCM is severely contaminated, use Isopropyl alcohol/Ethyl alcohol to clean. Other solvents may damage the polarizer. The following solvents is especially prohibited: water , ketone Aromatic solvents etc.
5. Exercise care to minimize corrosion of the electrode. Corrosion of the electrodes is accelerated by water droplets, moisture condensation or a current flow in a high-humidity environment.
6. Install the LCD Module by using the mounting holes. When mounting the LCD module make sure it is free of twisting, warping and distortion. In particular, do not forcibly pull or bend the I/O cable or the backlight cable.
7. Don't disassemble the LCM.
8. To prevent destruction of the elements by static electricity, be careful to maintain an optimum work environment.
  - Be sure to ground the body when handling the LCD modules.
  - Tools required for assembling, such as soldering irons, must be properly grounded.
  - To reduce the amount of static electricity generated, do not conduct assembling and other work under dry conditions.
  - The LCD module is coated with a film to protect the display surface. Exercise care when peeling off this protective film since static electricity may be generated.
9. Do not alter, modify or change the the shape of the tab on the metal frame.
10. Do not make extra holes on the printed circuit board, modify its shape or change the positions of components to be attached.
11. Do not damage or modify the pattern writing on the printed circuit board.
12. Absolutely do not modify the zebra rubber strip (conductive rubber) or heat seal connector
13. Except for soldering the interface, do not make any alterations or modifications with a soldering iron.
14. Do not drop, bend or twist LCM.

### 12.2 Storage

1. Store in an ambient temperature of 5 to 45 C, and in a relative humidity of 40% to 60%. Don't expose to sunlight or fluorescent light.
2. Storage in a clean environment, free from dust, active gas, and solvent.
3. Store in antistatic container.

