

PRODUCT SPECIFICATION

3.5"TN TFT LCD MODULE

MODEL: T035320480-A5TMN-043 Ver:1.0



- < ◇ > Preliminary Specification
- < ◆ > Finally Specification

CUSTOMER'S APPROVAL	
CUSTOMER :	
SIGNATURE:	DATE:

APPROVED BY	PM REVIEWED	PD REVIEWED	PREPARED BY

Revision History

Revision	Date	Originator	Detail	Remarks
1.0	2017.06.15	ZFY	Initial Release	

Table of Contents

No.	Item	Page
1.	General Description.....	4
2.	Module Parameter.....	4
3.	Absolute Maximum Ratings.....	4
4.	DC Characteristics	5
5.	Backlight Characteristic.....	5
5.1.	Backlight Characteristics	5
5.2.	Backlighting circuit.....	5
6.	Optical Characteristics	6
6.1.	Optical Characteristics	6
6.2.	Definition of Response Time	6
6.3.	Definition of Contrast Ratio	7
6.4.	Definition of Viewing Angles	7
6.5.	Definition of Color Appearance.....	8
6.6.	Definition of Surface Luminance, Uniformity and Transmittance	8
7.	Block Diagram and Power Supply.....	9
8.	Interface Pins Definition	10
9.	AC Characteristics.....	12
10.	Quality Assurance	17
10.1	Purpose	17
10.2	Standard for Quality Test	17
10.3	Nonconforming Analysis & Disposition.....	17
10.4	Agreement Items	17
10.5	Standard of the Product Visual Inspection	17
10.6	Inspection Specification.....	18
10.7	Classification of Defects	22
10.8	Identification/marketing criteria.....	22
10.9	Packaging.....	22
11.	Reliability Specification.....	23
12.	Precautions and Warranty.....	24
12.1	Safety	24
12.2	Handling	24
12.3	Storage	24
12.4	Metal Pin (Apply to Products with Metal Pins)	24
12.4	Operation.....	25
12.5	Static Electricity	25
12.6	Limited Warranty	25
13.	Packaging.....	26
14.	Outline Drawing.....	27

1. General Description

The specification is a transmissive type color active matrix liquid crystal display (LCD) which uses amorphous thin film transistor (TFT) as switching devices. This product is composed of a TFT-LCD panel, driver ICs and a backlight unit.

2. Module Parameter

Features	Details	Unit
Display Size(Diagonal)	3.5"	
LCD type	TN TFT	
Display Mode	Transmissive /Normally White	
Resolution	320RGB x 480	Pixels
View Direction	6 O'clock	Best Image
Gray Scale Inversion Direction	12 O'clock	
Module Outline	54.48(H) x 84.71(V) x 2.3(T) (Note1)	mm
Active Area	48.96 (H) x73.44(V)	mm
Pixel Pitch	153(H) x 153(V)	um
Pixel Arrangement	RGB Vertical Stripe	
Display Colors	262K	
Interface	RGB or 8/9/16/18 Parallel Interface	
Driver IC	ILI9488	-
With or Without Touch Panel	Without	
Operating Temperature	-20~70	°C
Storage Temperature	-30~80	°C
Weight	20	g

Note 1: Exclusive hooks, posts, FFC/FPC tail etc.

3. Absolute Maximum Ratings

GND =0V, Ta=25°C

Item	Symbol	Min.	Max.	Unit
Power supply voltage	VCC	-0.3	3.3	V
	IOVCC	-0.3	3.3	V
Storage temperature	T _{STG}	-30	+80	°C
Operating temperature	T _{OP}	-20	+70	°C

Note 1: If Ta below 50°C, the maximal humidity is 90%RH, if Ta over 50°C, absolute humidity should be less than 60%RH.

Note 2: The response time will be extremely slow when the operating temperature is around -10°C, and the back ground will become darker at high temperature operating.

4. DC Characteristics

Item	Symbol	Min.	Typ.	Max.	Unit	
Supply Voltage	VCC	2.5	2.8	3.3	V	
	IOVCC	1.65	1.8	3.3	V	
Logic Low input voltage	V _{IL}	-0.3	-	0.3*IOVCC	V	
Logic High input voltage	V _{IH}	0.7*IOVCC	-	IOVCC	V	
Logic Low output voltage	V _{OL}	0	-	0.2*IOVCC	V	
Logic High output voltage	V _{OH}	0.8*IOVCC	-	IOVCC	V	
Current Consumption All Black	Logic	I _{CC+} I _{IN}	-	(10)	-	mA
	Analog					

5. Backlight Characteristic

5.1. Backlight Characteristics

Item	Symbol	Condition	Min.	Typ.	Max.	Unit
Forward Voltage	V _F	T _a =25 °C, I _F =20mA/LED	16.8	19.2	20.4	V
Forward Current	I _F	T _a =25 °C, V _F =3.2V/LED	-	20	-	mA
Power dissipation	P _D	-	-	384	-	mW
Uniformity	Avg	-	-	80	-	%
Drive method	Constant current					
LED Configuration	6 White LEDs in serial					

5.2. Backlighting circuit

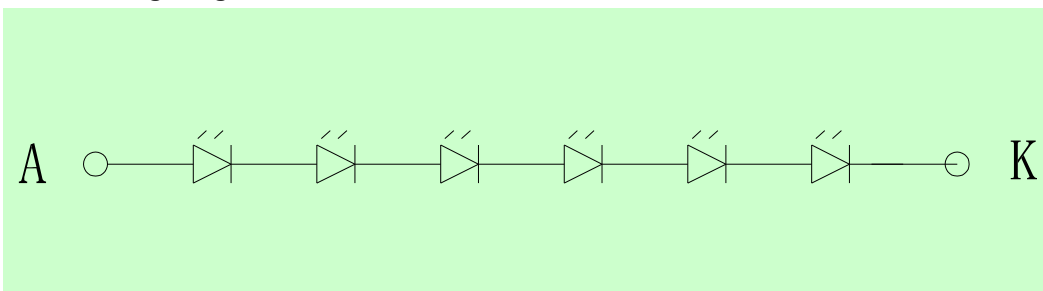

6. Optical Characteristics

6.1. Optical Characteristics

Ta=25°C, VCC=2.8V, TN LC+ Polarizer

	Item	Symbol	Condition	Specification			Unit	
				Min.	Typ.	Max.		
Backlight On (Transmissive Mode)	Luminance on TFT($I_f=20\text{mA/LED}$)	Lv	Normally viewing angle $\theta_x = \phi_y = 0^\circ$	(270)	(340)	-	cd/m ²	
	Contrast ratio(See 6.3)	CR		400	500	-		
	Response time (See 6.2)	T _R		-	16	32	ms	
		T _F						
	Chromaticity Transmissive (See 6.5)	Red	X _R	Center CR≥10	0.556	0.606	0.656	-
			Y _R		0.299	0.349	0.399	-
		Green	X _G		0.256	0.306	0.356	-
			Y _G		0.564	0.614	0.664	-
		Blue	X _B		0.097	0.147	0.197	-
			Y _B		0.035	0.085	0.135	-
	White	X _W	0.245	0.295	0.345	-		
		Y _W	0.277	0.327	0.377	-		
	Viewing Angle (See 6.4)	Horizontal	θ_{x+}	Center CR≥10	60	70	-	Deg.
θ_{x-}			60		70	-		
Vertical		ϕ_{y+}	60		70	-		
		ϕ_{y-}	40		60	-		
NTSC Ratio(Gamut)	-	-	-	60	-	%		

6.2. Definition of Response Time

6.2.1. Normally Black Type (Negative)

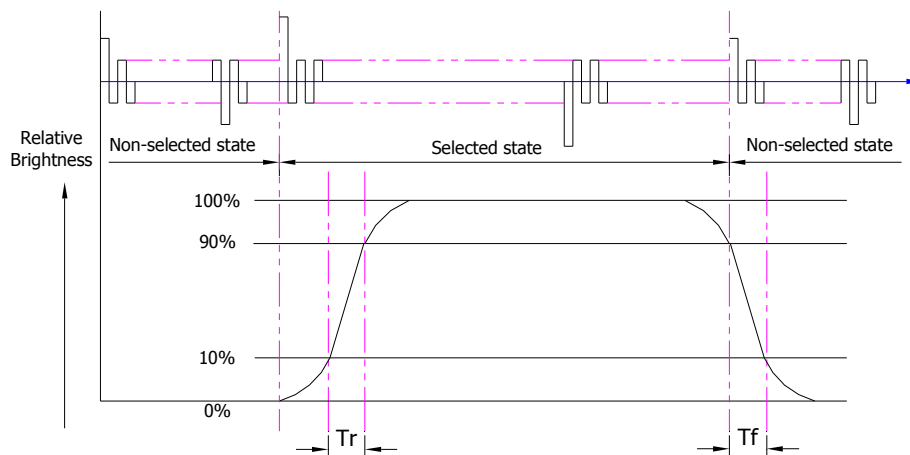

Tr is the time it takes to change from non-selected stage with relative luminance 10% to selected state with relative luminance 90%;

Tf is the time it takes to change from selected state with relative luminance 90% to non-selected state with relative luminance 10%.

Note: Measuring machine: LCD-5100

6.2.2. Normally White Type (Positive)

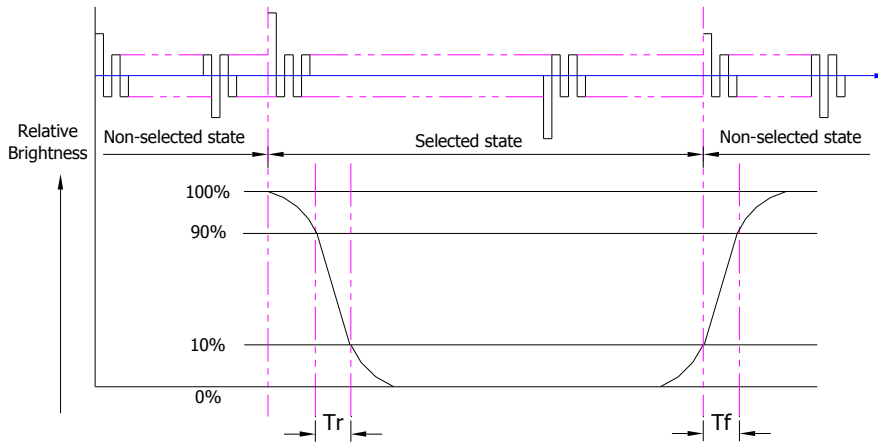

Tr is the time it takes to change from non-selected stage with relative luminance 90% to selected state with relative luminance 10%;
Tf is the time it takes to change from selected state with relative luminance 10% to non-selected state with relative luminance 90%;

Note: Measuring machine: LCD-5100 or EQUI

6.3. Definition of Contrast Ratio

Contrast is measured perpendicular to display surface in reflective and transmissive mode. The measurement condition is:

Measuring Equipment	Eldim or Equivalent
Measuring Point Diameter	3mm//1mm
Measuring Point Location	Active Area centre point
Test pattern	A: All Pixels white
	B: All Pixel black
Contrast setting	Maximum

Definitions: CR (Contrast) = Luminance of White Pixel / Luminance of Black Pixel

6.4. Definition of Viewing Angles

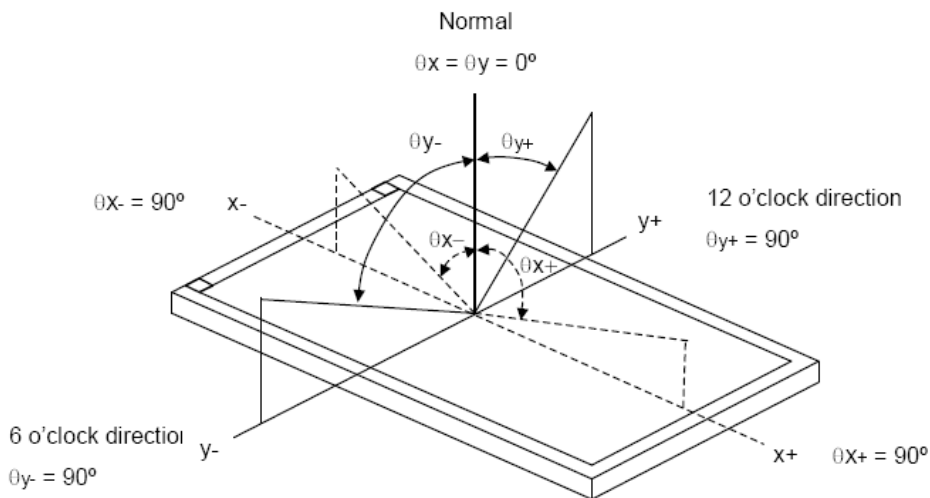

Measuring machine: LCD-5100 or EQUI

6.5. Definition of Color Appearance

R,G,B and W are defined by (x, y) on the IE chromaticity diagram

NTSC=area of RGB triangle/area of NTSC triangleX100%

Measuring picture: Red, Green, Blue and White (Measuring machine: BM-7)

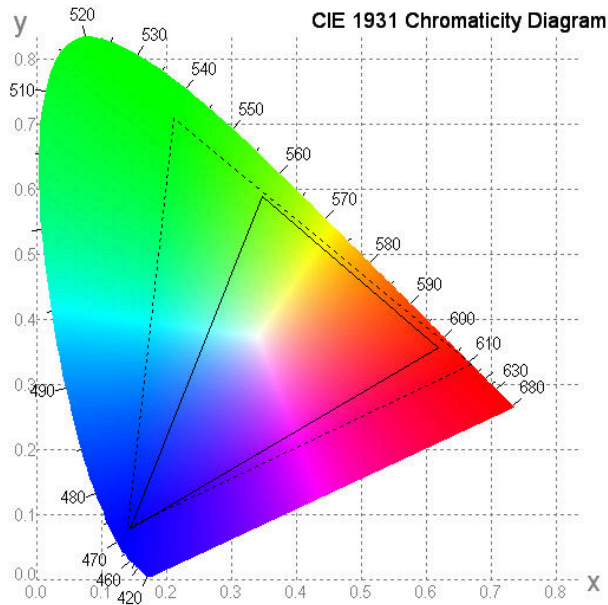

6.6. Definition of Surface Luminance, Uniformity and Transmittance

Using the transmissive mode measurement approach, measure the white screen luminance of the display panel and backlight.

6.6.1. Surface Luminance: $L_V = \text{average} (L_{P1}:L_{P9})$

6.6.2. Uniformity = Minimal ($L_{P1}:L_{P9}$) / Maximal ($L_{P1}:L_{P9}$) * 100%

6.6.3. Transmittance = L_V on LCD / L_V on Backlight * 100%

Note: Measuring machine: BM-7

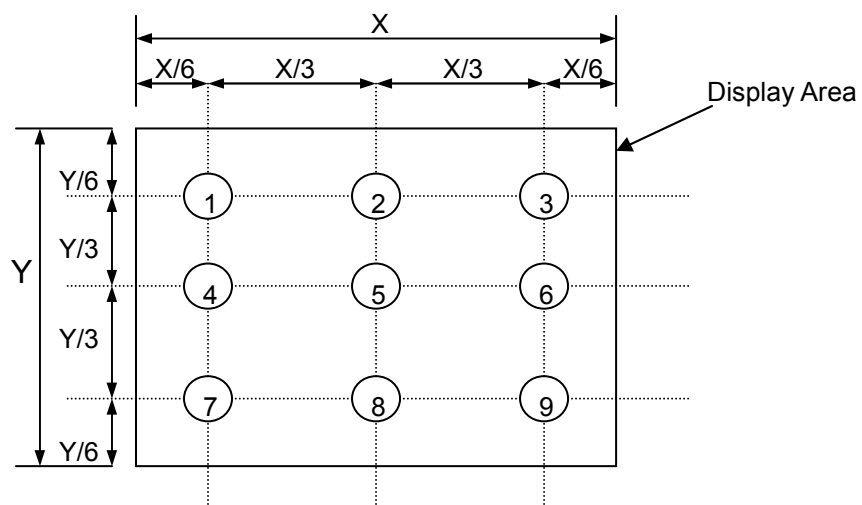

7. Block Diagram and Power Supply

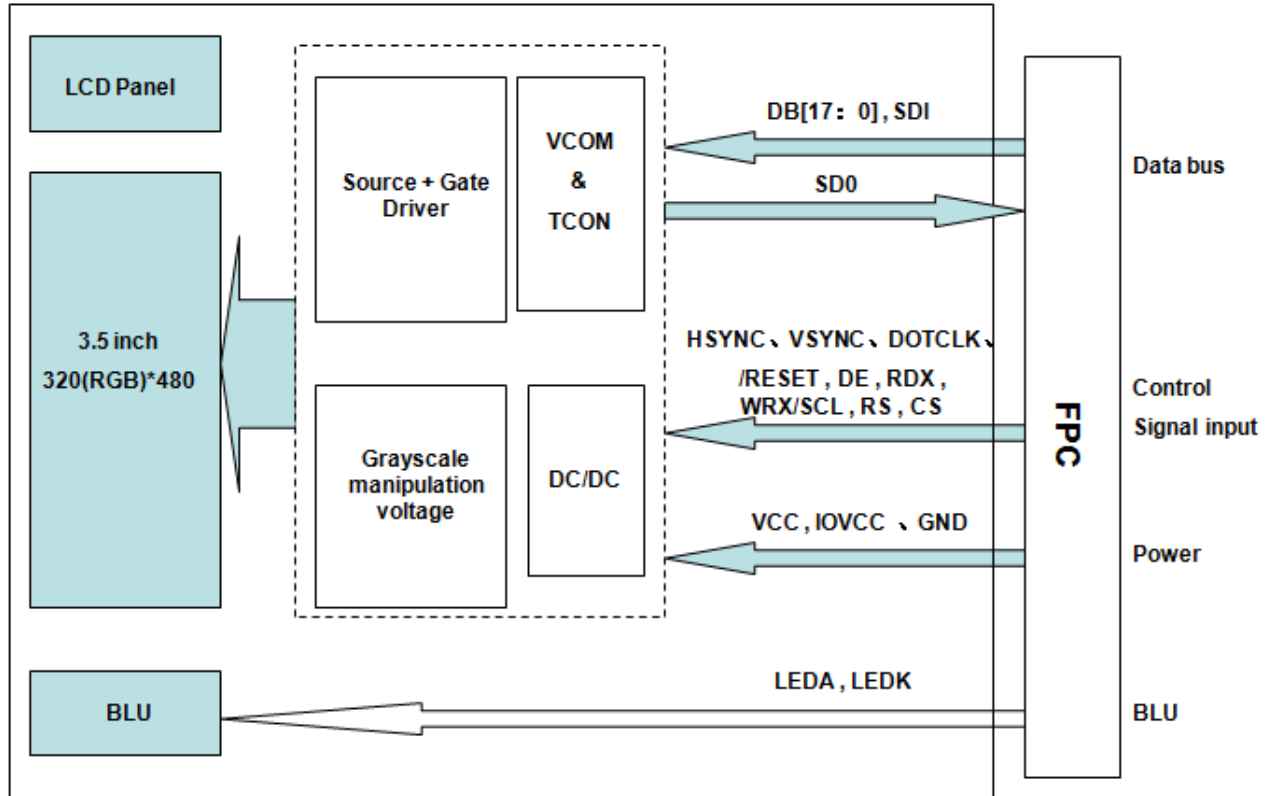

8. Interface Pins Definition

Connector type : FH35C-45S-0.3SHW

No.	Symbol	Function
1	GND	Power Ground
2	LEDA	Anode for back light driver voltage
3	LEDA	Anode for back light driver voltage
4	LEDK	Cathode for back light driver voltage
5	LEDK	Cathode for back light driver voltage
6	GND	Power Ground
7	GND	Power Ground
8	VCC	Power supply
9	IOVCC	Power supply
10	/RESET	Reset input pin. Signal is active low.
11	VSYNC	Vertical Sync Signal
12	HSYNC	Horizontal Sync Signal
13	GND	Power Ground
14	DOTCLK	Pixel clock signal
15	GND	Power Ground
16	DE	Data Enable signal.
17	DB17	Data bus
18	DB16	Data bus
19	DB15	Data bus
20	DB14	Data bus
21	DB13	Data bus
22	DB12	Data bus
23	DB11	Data bus
24	DB10	Data bus
25	DB9	Data bus
26	DB8	Data bus
27	DB7	Data bus
28	DB6	Data bus
29	DB5	Data bus
30	DB4	Data bus
31	DB3	Data bus
32	DB2	Data bus
33	DB1	Data bus
34	DB0	Data bus
35	SDO	Serial data output
36	SDI	Serial data input pin.
37	RDX	LCD driver read enable
38	WRX/SCL	DBI Type B:WRX pin, serves as a write signal DBI Type C:SCL pin as Serial Clock when operates in the serial

		interface
39	RS	Command/Display data selection signal
40	CS	Chip select signal
41	TE	Tearing effect output pin
42	NC(XR)	No Connection
43	NC(YD)	No Connection
44	NC(XL)	No Connection
45	NC(YU)	No Connection

Notes:

1. $T_a = -30$ to 70 °C, $IOVCC = 1.65V$ to $3.3V$, $VCI = 2.5V$ to $3.3V$, $AGND = DGND = 0V$
2. Logic high and low levels are specified as 30% and 70% of $IOVCC$ for input signals.
3. Input signal rising time and falling time:

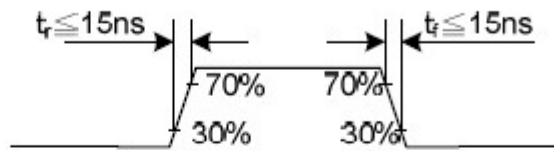

4. The CSX timing:

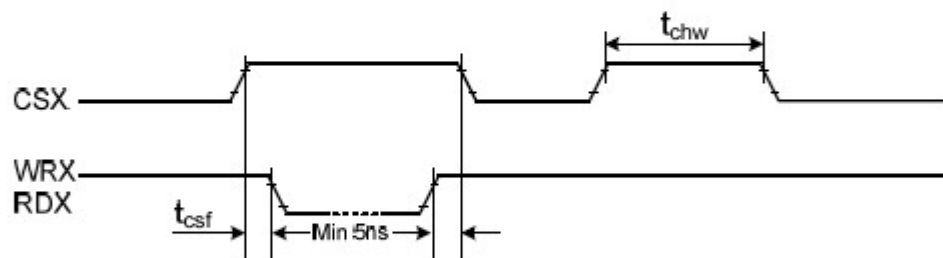

5. The Write to Read or the Read to Write timing:

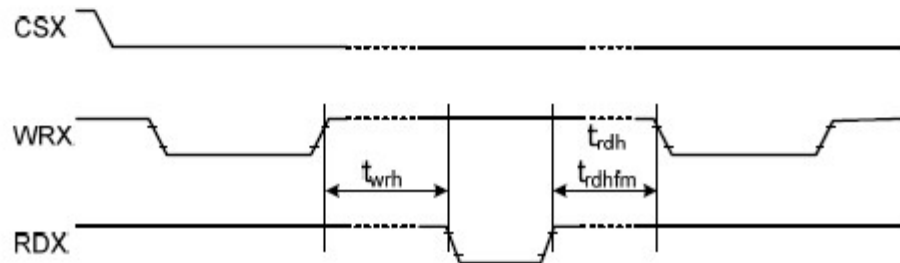

9.2. DBI Type C Option 1 (3-Line SPI System) Timing Characteristics

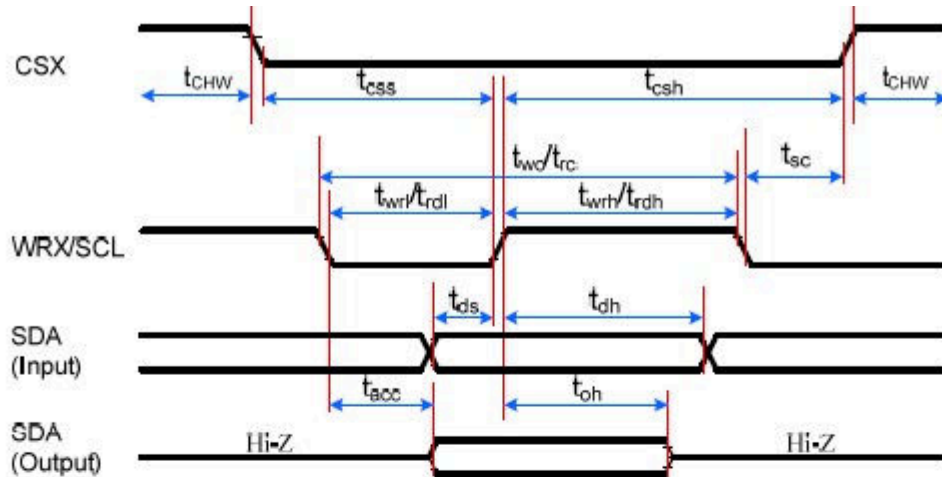

Signal	Symbol	Parameter	min	max	Unit	Description
CSX	t _{sc}	SCL-CSX	15	-	ns	
	t _{chW}	CSX H Pulse Width	40	-	ns	
	t _{css}	Chip select time (Write)	60	-	ns	
	t _{csh}	Chip select hold time (Read)	65	-	ns	
SCL	t _{wc}	Serial Clock Cycle (Write)	66	-	ns	
	t _{wrh}	SCL H Pulse Width (Write)	15	-	ns	
	t _{wrl}	SCL L Pulse Width (Write)	15	-	ns	
	t _{rc}	Serial Clock Cycle (Read)	150	-	ns	
	t _{rdh}	SCL H Pulse Width (Read)	60	-	ns	
	t _{rdl}	SCL L Pulse Width (Read)	60	-	ns	
SDA/SDI (Input)	t _{ds}	Data setup time (Write)	10	-	ns	
	t _{dh}	Data hold time (Write)	10	-	ns	
SDA/SDO (Output)	t _{acc}	Access time (Read)	10	50	ns	For maximum CL=30pF
	t _{oh}	Output disable time (Read)	15	50	ns	For minimum CL=8pF

Note: T_a = -30 to 70 °C, I_{OVCC} = 1.65V to 3.6V, V_{CI} = 2.5V to 3.6V, AGND = DGND = 0V, T = 10+/-0.5ns

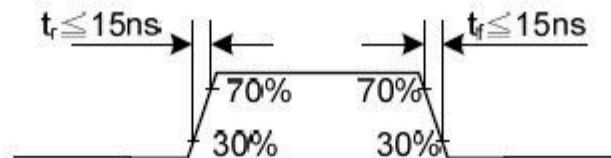

9.3. DBI Type C Option 3 (4-Line SPI System) Timing Characteristics

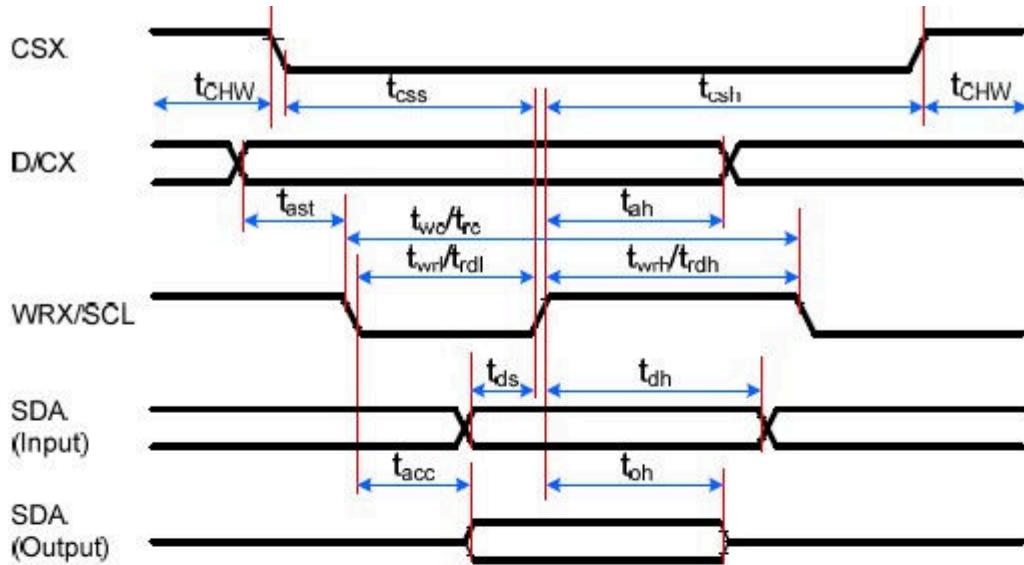

Signal	Symbol	Parameter	min	max	Unit	Description
CSX	tcss	Chip select time (Write)	15	-	ns	
	tcsh	Chip select hold time (Read)	15	-	ns	
	tCHW	CS H pulse width	40	-	ns	
SCL	twc	Serial clock cycle (Write)	50	-	ns	
	twrh	SCL H pulse width (Write)	10	-	ns	
	twrl	SCL L pulse width (Write)	10	-	ns	
	trc	Serial clock cycle (Read)	150	-	ns	
	trdh	SCL H pulse width (Read)	60	-	ns	
	trdl	SCL L pulse width (Read)	60	-	ns	
D/CX	tas	D/CX setup time	10	-	ns	
	tah	D/CX hold time (Write/Read)	10	-	ns	
SDA/SDI (Input)	tds	Data setup time (Write)	10	-	ns	
	tdh	Data hold time (Write)	10	-	ns	
SDA/SDO (Output)	tacc	Access time (Read)	10	50	ns	For maximum CL=30pF
	tod	Output disable time (Read)	15	50	ns	For minimum CL=8pF

Notes:

1. Ta = -30 to 70 °C, IOVCC = 1.65V to 3.3V, VCI = 2.5V to 3.3V, AGND = DGND = 0V, T = 10+/-0.5ns.
2. Does not include signal rising and falling times.

9.4. DPI (Display Parallel 16-/18-/24-bit interface) Timing Characteristics

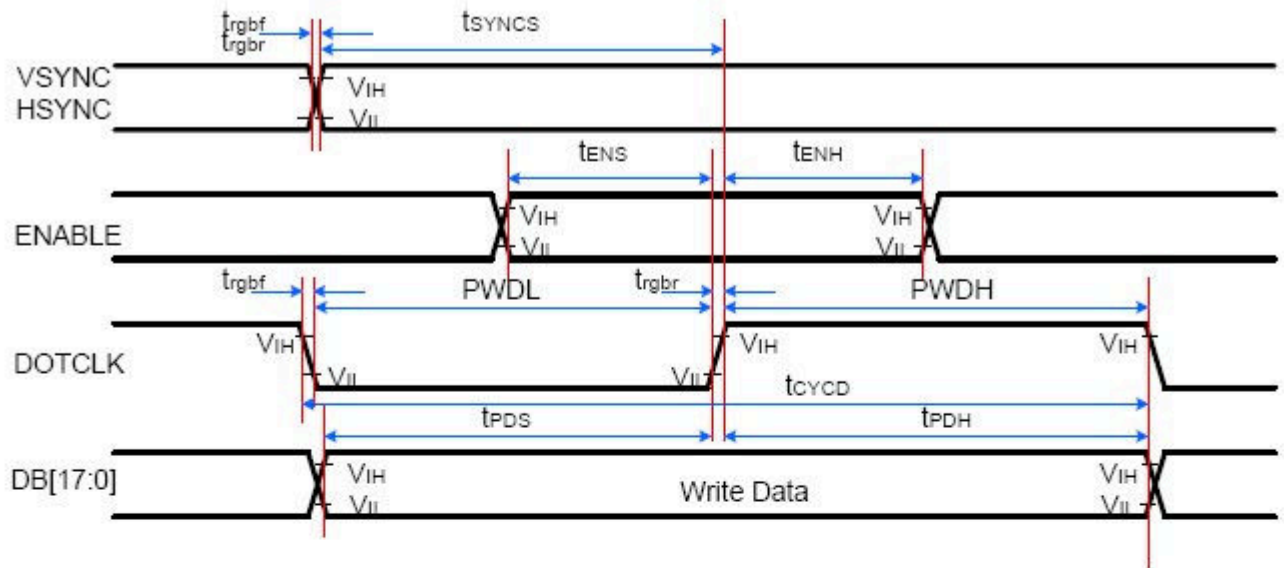

Signal	Symbol	Parameter	min	max	Unit	Description
VSYNC/ HSYNC	t_{SYNCS}	VSYNC/HSYNC setup time	15	-	ns	16-/18-/24-bit bus RGB interface mode
	t_{SYNCH}	VSYNC/HSYNC hold time	15	-	ns	
ENABLE	t_{ENS}	ENABLE setup time	15	-	ns	
	t_{ENH}	ENABLE hold time	15	-	ns	
DB [23:0]	t_{PDS}	Data setup time	15	-	ns	
	t_{PDH}	Data hold time	15	-	ns	
DOTCLK	PWDH	DOTCLK high-level period	20	-	ns	
	PVDL	DOTCLK low-level period	20	-	ns	
	t_{CYCD}	DOTCLK cycle time	50	-	ns	
	t_{rgbr}, t_{rgbf}	DOTCLK,HSYNC,VSYNC rise/fall time	-	15	ns	

Note: $T_a = -30$ to 70 °C, IOVCC = 1.65V to 3.3V, VCI = 2.5V to 3.3V, AGND = DGND = 0V

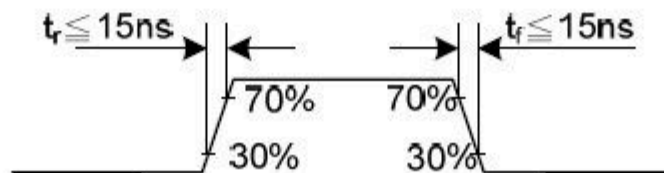

10. Quality Assurance

10.1 Purpose

This standard for Quality Assurance assures the quality of LCD module products supplied to customer.

10.2 Standard for Quality Test

10.2.1 Sampling Plan:

GB2828.1-2012

Single sampling, general inspection level II

10.2.2 Sampling Criteria:

Visual inspection: AQL 1.5%

Electrical functional: AQL 0.65%.

10.2.3 Reliability Test:

Detailed requirement refer to Reliability Test Specification.

10.3 Nonconforming Analysis & Disposition

10.3.1 Nonconforming analysis:

10.3.1.1 Customer should provide overall information of non-conforming sample for their complaints.

10.3.1.2 After receipt of detailed information from customer, the analysis of nonconforming parts usually should be finished in one week.

10.3.1.3 If cannot finish the analysis on time, customer will be notified with the progress status.

10.3.2 Disposition of nonconforming:

10.3.2.1 Non-conforming product over PPM level will be replaced.

10.3.2.2 The cause of non-conformance will be analyzed. Corrective action will be discussed and implemented.

10.4 Agreement Items

Shall negotiate with customer if the following situation occurs:

10.4.1 There is any discrepancy in standard of quality assurance.

10.4.2 Additional requirement to be added in product specification.

10.4.3 Any other special problem.

10.5 Standard of the Product Visual Inspection

10.5.1 Appearance inspection:

10.5.1.1 The inspection must be under illumination about 1000 – 1500 lx, and the distance of view must be at 30cm ± 2cm.

10.5.1.2 The viewing angle should be 45° from the vertical line without reflection light or follows customer's viewing angle specifications.

10.5.1.3 Definition of area: A Zone: Active Area, B Zone: Viewing Area,

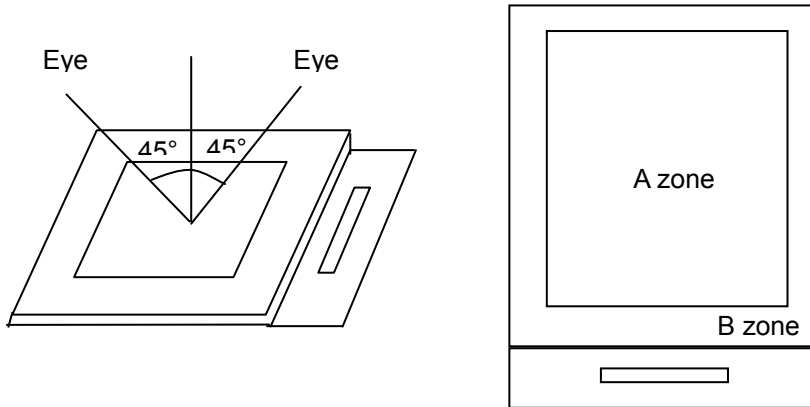

10.5.2 Basic principle:

10.5.2.1 A set of sample to indicate the limit of acceptable quality level must be discussed by both us and customer when there is any dispute happened.

10.5.2.2 New item must be added on time when it is necessary.

10.6 Inspection Specification

No.	Item	Criteria (Unit: mm)																				
01	Black / White spot Foreign material (Round type) Pinholes Stain Particles inside cell. (Minor defect)	$\phi = (a + b) / 2$	<table border="1"> <thead> <tr> <th>Size</th> <th>Area</th> <th>Acc. Qty</th> </tr> </thead> <tbody> <tr> <td>$\phi \leq 0.10$</td> <td></td> <td>Ignore</td> </tr> <tr> <td>$0.10 < \phi \leq 0.15$</td> <td></td> <td>2</td> </tr> <tr> <td>$0.15 < \phi \leq 0.25$</td> <td></td> <td>1</td> </tr> <tr> <td>$0.25 < \phi$</td> <td></td> <td>0</td> </tr> <tr> <td>Total</td> <td></td> <td>2 no include $\phi \leq 0.10$</td> </tr> </tbody> </table>		Size	Area	Acc. Qty	$\phi \leq 0.10$		Ignore	$0.10 < \phi \leq 0.15$		2	$0.15 < \phi \leq 0.25$		1	$0.25 < \phi$		0	Total		2 no include $\phi \leq 0.10$
			Size	Area	Acc. Qty																	
$\phi \leq 0.10$		Ignore																				
$0.10 < \phi \leq 0.15$		2																				
$0.15 < \phi \leq 0.25$		1																				
$0.25 < \phi$		0																				
Total		2 no include $\phi \leq 0.10$																				
Distance between 2 defects should more than 3mm apart.																						
02	Electrical Defect (Minor defect)	<table border="1"> <thead> <tr> <th></th> <th>Display Area</th> <th>Total</th> <th rowspan="3">Note1</th> </tr> </thead> <tbody> <tr> <td>Bright dot</td> <td>0</td> <td>0</td> </tr> <tr> <td>Dark dot</td> <td>N ≤ 2</td> <td>N ≤ 2</td> </tr> <tr> <td>Total dot</td> <td>N ≤ 2</td> <td>N ≤ 2</td> <td></td> </tr> <tr> <td>Mura</td> <td colspan="2">Not visible through 5% ND filters.</td> <td>Note 2</td> </tr> </tbody> </table>				Display Area	Total	Note1	Bright dot	0	0	Dark dot	N ≤ 2	N ≤ 2	Total dot	N ≤ 2	N ≤ 2		Mura	Not visible through 5% ND filters.		Note 2
			Display Area	Total	Note1																	
		Bright dot	0	0																		
		Dark dot	N ≤ 2	N ≤ 2																		
Total dot	N ≤ 2	N ≤ 2																				
Mura	Not visible through 5% ND filters.		Note 2																			
Remark:																						
1. Bright dot caused by scratch and foreign object accords to item 1.																						
1.																						

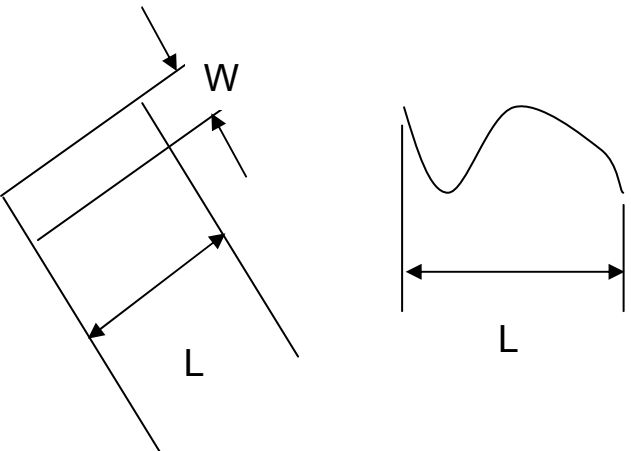
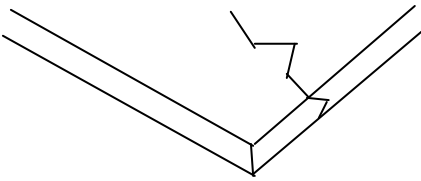
<p>03</p>	<p>Black and White line Scratch Foreign material (Line type) (Minor defect)</p>	 <table border="1" data-bbox="614 750 1236 1064"> <thead> <tr> <th>Length</th> <th>Width</th> <th>Acc. Qty</th> </tr> </thead> <tbody> <tr> <td>/</td> <td>$W \leq 0.03$</td> <td>Ignore</td> </tr> <tr> <td>$L \leq 2.5$</td> <td>$0.03 < W \leq 0.05$</td> <td>3</td> </tr> <tr> <td>$L \leq 2.5$</td> <td>$0.05 < W \leq 0.10$</td> <td>2</td> </tr> <tr> <td>/</td> <td>$0.1 < W$</td> <td>0</td> </tr> <tr> <td colspan="2">Total</td> <td>3</td> </tr> </tbody> </table> <p>Distance between 2 defects should more than 3mm apart. Scratches not viewable through the back of the display are acceptable.</p>	Length	Width	Acc. Qty	/	$W \leq 0.03$	Ignore	$L \leq 2.5$	$0.03 < W \leq 0.05$	3	$L \leq 2.5$	$0.05 < W \leq 0.10$	2	/	$0.1 < W$	0	Total		3
Length	Width	Acc. Qty																		
/	$W \leq 0.03$	Ignore																		
$L \leq 2.5$	$0.03 < W \leq 0.05$	3																		
$L \leq 2.5$	$0.05 < W \leq 0.10$	2																		
/	$0.1 < W$	0																		
Total		3																		
<p>04</p>	<p>Glass Crack (Minor defect)</p>	 <p>Crack is potential to enlarge, any type is not allowed.</p>																		

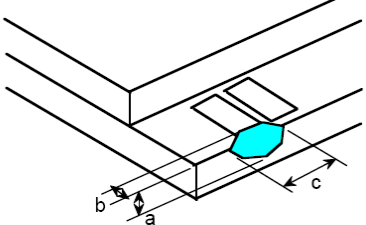
<p>05</p>	<p>Glass Chipping Pad Area: (Minor defect)</p> 	<table border="1" data-bbox="869 1792 1340 1960"> <thead> <tr> <th>Length and Width</th> <th>Acc. Qty</th> </tr> </thead> <tbody> <tr> <td>$c > 3.0, b < 1.0$</td> <td>1</td> </tr> <tr> <td>$c < 3.0, b < 1.0$</td> <td>3</td> </tr> <tr> <td colspan="2">$a < \text{Glass Thickness}$</td> </tr> </tbody> </table>	Length and Width	Acc. Qty	$c > 3.0, b < 1.0$	1	$c < 3.0, b < 1.0$	3	$a < \text{Glass Thickness}$	
Length and Width	Acc. Qty									
$c > 3.0, b < 1.0$	1									
$c < 3.0, b < 1.0$	3									
$a < \text{Glass Thickness}$										

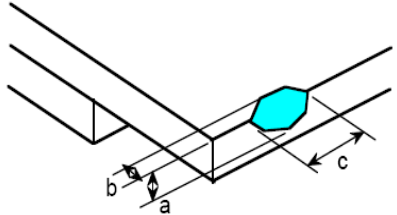
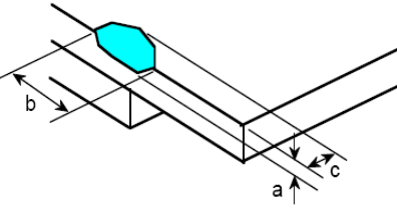
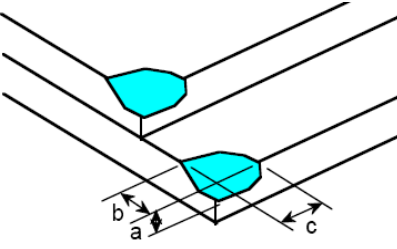
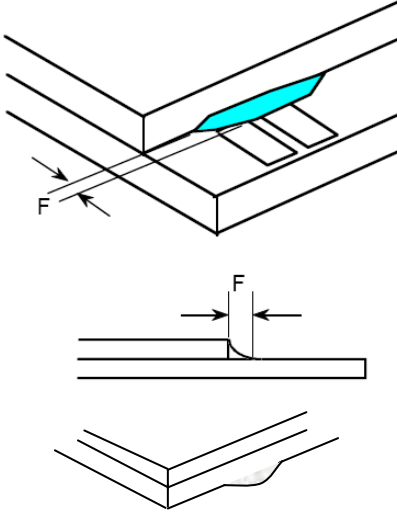
<p>06</p>	<p>Glass Chipping Rear of Pad Area: (Minor defect)</p> 	<table border="1"> <thead> <tr> <th>Length and Width</th> <th>Acc. Qty</th> </tr> </thead> <tbody> <tr> <td>$c > 3.0, b < 1.0$</td> <td>1</td> </tr> <tr> <td>$c < 3.0, b < 1.0$</td> <td>2</td> </tr> <tr> <td>$c < 3.0, b < 0.5$</td> <td>4</td> </tr> <tr> <td colspan="2">$a < \text{Glass Thickness}$</td> </tr> </tbody> </table>	Length and Width	Acc. Qty	$c > 3.0, b < 1.0$	1	$c < 3.0, b < 1.0$	2	$c < 3.0, b < 0.5$	4	$a < \text{Glass Thickness}$	
Length and Width	Acc. Qty											
$c > 3.0, b < 1.0$	1											
$c < 3.0, b < 1.0$	2											
$c < 3.0, b < 0.5$	4											
$a < \text{Glass Thickness}$												
<p>07</p>	<p>Glass Chipping Except Pad Area: (Minor defect)</p> 	<table border="1"> <thead> <tr> <th>Length and Width</th> <th>Acc. Qty</th> </tr> </thead> <tbody> <tr> <td>$c > 3.0, b < 1.0$</td> <td>1</td> </tr> <tr> <td>$c < 3.0, b < 1.0$</td> <td>2</td> </tr> <tr> <td>$c < 3.0, b < 0.5$</td> <td>4</td> </tr> <tr> <td colspan="2">$a < \text{Glass Thickness}$</td> </tr> </tbody> </table>	Length and Width	Acc. Qty	$c > 3.0, b < 1.0$	1	$c < 3.0, b < 1.0$	2	$c < 3.0, b < 0.5$	4	$a < \text{Glass Thickness}$	
Length and Width	Acc. Qty											
$c > 3.0, b < 1.0$	1											
$c < 3.0, b < 1.0$	2											
$c < 3.0, b < 0.5$	4											
$a < \text{Glass Thickness}$												
<p>08</p>	<p>Glass Corner Chipping: (Minor defect)</p> 	<table border="1"> <thead> <tr> <th>Length and Width</th> <th>Acc. Qty</th> </tr> </thead> <tbody> <tr> <td>$c < 3.0, b < 3.0$</td> <td>Ignore</td> </tr> <tr> <td colspan="2">$a < \text{Glass Thickness}$</td> </tr> </tbody> </table>	Length and Width	Acc. Qty	$c < 3.0, b < 3.0$	Ignore	$a < \text{Glass Thickness}$					
Length and Width	Acc. Qty											
$c < 3.0, b < 3.0$	Ignore											
$a < \text{Glass Thickness}$												
<p>09</p>	<p>Glass Burr: (Minor defect)</p> 	<table border="1"> <thead> <tr> <th>Length</th> <th>Acc. Qty</th> </tr> </thead> <tbody> <tr> <td>$F < 1.0$</td> <td>Ignore</td> </tr> </tbody> </table> <p>Glass burr don't affect assemble and module dimension.</p>	Length	Acc. Qty	$F < 1.0$	Ignore						
Length	Acc. Qty											
$F < 1.0$	Ignore											

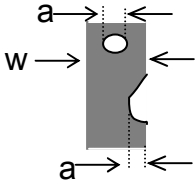
<p>10</p>	<p>FPC Defect: (Minor defect)</p> 	<p>10.1 Dent, pinhole width $a < w/3$. (w: circuitry width.) 10.2 Open circuit is unacceptable. 10.3 No oxidation, contamination and distortion.</p>										
<p>11</p>	<p>Bubble on Polarizer (Minor defect)</p>	<table border="1"> <thead> <tr> <th>Diameter</th> <th>Acc. Qty</th> </tr> </thead> <tbody> <tr> <td>$\phi \leq 0.20$</td> <td>Ignore</td> </tr> <tr> <td>$0.20 < \phi \leq 0.30$</td> <td>4</td> </tr> <tr> <td>$0.30 < \phi \leq 0.50$</td> <td>1</td> </tr> <tr> <td>$0.50 < \phi$</td> <td>None</td> </tr> </tbody> </table>	Diameter	Acc. Qty	$\phi \leq 0.20$	Ignore	$0.20 < \phi \leq 0.30$	4	$0.30 < \phi \leq 0.50$	1	$0.50 < \phi$	None
Diameter	Acc. Qty											
$\phi \leq 0.20$	Ignore											
$0.20 < \phi \leq 0.30$	4											
$0.30 < \phi \leq 0.50$	1											
$0.50 < \phi$	None											
<p>12</p>	<p>Dent on Polarizer (Minor defect)</p>	<table border="1"> <thead> <tr> <th>Diameter</th> <th>Acc. Qty</th> </tr> </thead> <tbody> <tr> <td>$\phi \leq 0.20$</td> <td>Ignore</td> </tr> <tr> <td>$0.20 < \phi \leq 0.30$</td> <td>4</td> </tr> <tr> <td>$0.30 < \phi \leq 0.50$</td> <td>1</td> </tr> <tr> <td>$0.50 < \phi$</td> <td>None</td> </tr> </tbody> </table>	Diameter	Acc. Qty	$\phi \leq 0.20$	Ignore	$0.20 < \phi \leq 0.30$	4	$0.30 < \phi \leq 0.50$	1	$0.50 < \phi$	None
Diameter	Acc. Qty											
$\phi \leq 0.20$	Ignore											
$0.20 < \phi \leq 0.30$	4											
$0.30 < \phi \leq 0.50$	1											
$0.50 < \phi$	None											
<p>13</p>	<p>Bezel</p>	<p>13.1 No rust, distortion on the Bezel. 13.2 No visible fingerprints, stains or other contamination.</p>										
<p>14</p>	<p>Touch Panel</p>	<p>D: Diameter W: width L: length 14.1 Spot: $D < 0.25$ is acceptable $0.25 \leq D \leq 0.4$ 2dots are acceptable and the distance between defects should more than 10 mm. $D > 0.4$ is unacceptable 14.2 Dent: $D > 0.40$ is unacceptable 14.3 Scratch: $W \leq 0.03$, $L \leq 10$ is acceptable, $0.03 < W \leq 0.10$, $L \leq 10$ is acceptable Distance between 2 defects should more than 10 mm. $W > 0.10$ is unacceptable.</p>										
<p>15</p>	<p>PCB</p>	<p>15.1 No distortion or contamination on PCB terminals. 15.2 All components on PCB must same as documented on the BOM/component layout. 15.3 Follow IPC-A-600F.</p>										

16	Soldering	Follow IPC-A-610C standard
17	Electrical Defect (Major defect)	<p>The below defects must be rejected.</p> <p>17.1 Missing vertical / horizontal segment, 17.2 Abnormal Display. 17.3 No function or no display. 17.4 Current exceeds product specifications. 17.5 LCD viewing angle defect. 17.6 No Backlight. 17.7 Dark Backlight. 17.8 Touch Panel no function.</p>

Remark: LCD Panel Broken shall be rejected. Defect out of LCD viewing area is acceptable.

10.7 Classification of Defects

10.7.1 Visual defects (Except no / wrong label) are treated as minor defect and electrical defect is major.

10.7.2 Two minor defects are equal to one major in lot sampling inspection.

10.8 Identification/marketing criteria

Any unit with illegible / wrong /double or no marking/ label shall be rejected.

10.9 Packaging

10.9.1 There should be no damage of the outside carton box, each packaging box should have one identical label.

10.9.2 Modules inside package box should have compliant mark.

10.9.3 All direct package materials shall offer ESD protection

Note1: Bright dot is defined as the defective area of the dot is larger than 50% of one sub-pixel area.

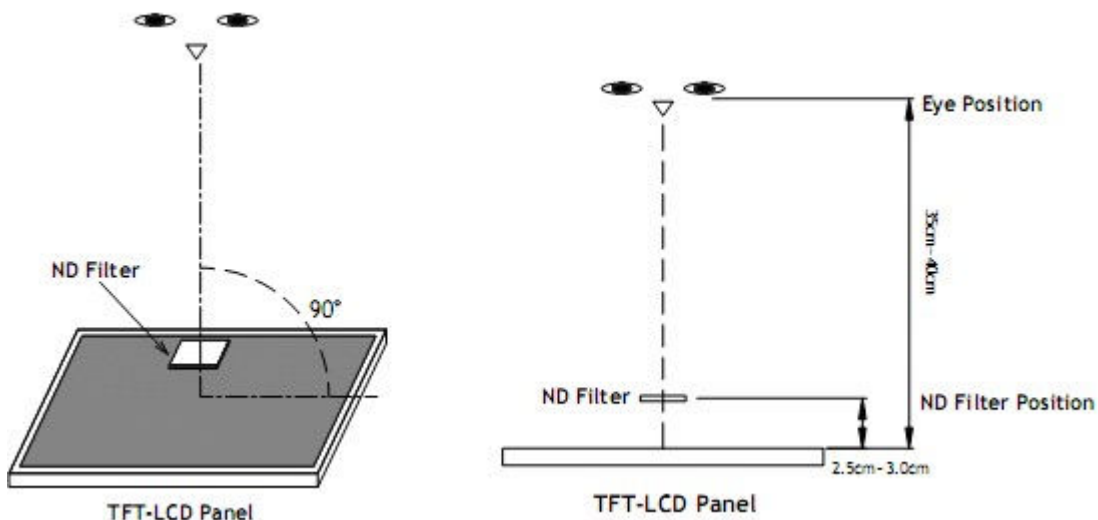

Bright dot: The bright dot size defect at black display pattern. It can be recognized by 2% transparency of filter when the distance between eyes and panel is $350\text{mm} \pm 50\text{mm}$.

Dark dot: Cyan, Magenta or Yellow dot size defect at white display pattern. It can be recognized by 5% transparency of filter when the distance between eyes and panel is $350\text{mm} \pm 50\text{mm}$.

Note2: Mura on display which appears darker / brighter against background brightness on parts of display area.

11. Reliability Specification

No	Item	Condition	Quantity	Criteria
1	High Temperature Operating	70°C, 96Hrs	2	GB/T2423.2-2008
2	Low Temperature Operating	-20°C, 96Hrs	2	GB/T2423.1-2008
3	High Humidity	50°C, 90%RH, 96Hrs	2	GB/T2423.3-2006
4	High Temperature Storage	80°C, 96Hrs	2	GB/T2423.2-2008
5	Low Temperature Storage	-30°C, 96Hrs	2	GB/T2423.1-2008
6	Thermal Cycling Test	-20°C, 60min~70°C, 60min, 20 cycles.	2	GB/T2423.22-2012
7	Packing vibration	Frequency range:10Hz~50Hz Acceleration of gravity:5G X, Y, Z 30 min for each direction.	2	GB/T5170.14-2009
8	Electrical Static Discharge	Air: ±8KV 150pF/330Ω 5 times Contact: ±4KV 150pF/330Ω 5 times	2	GB/T17626.2-2006
9	Drop Test (Packaged)	Height:80 cm,1 corner, 3 edges, 6 surfaces.	2	GB/T2423.8-1995

Note1. No deflection cosmetic and operational function allowable.

Note2. Total current Consumption should be below double of initial value

12. Precautions and Warranty

12.1 Safety

12.1.1 The liquid crystal in the LCD is poisonous. Do not put it in your mouth. If the liquid crystal touches your skin or clothes, wash it off immediately using soap and water.

12.1.2 Since the liquid crystal cells are made of glass, do not apply strong impact on them. Handle with care.

12.2 Handling

12.2.1 Reverse and use within ratings in order to keep performance and prevent damage.

12.2.2 Do not wipe the polarizer with dry cloth, as it might cause scratch. If the surface of the LCD needs to be cleaned, wipe it swiftly with cotton or other soft cloth soaked with petroleum IPA, do not use other chemicals.

12.3 Storage

12.3.1 Do not store the LCD module beyond the specified temperature ranges.

12.4 Metal Pin (Apply to Products with Metal Pins)

12.4.1 Pins of LCD and Backlight

12.4.1.1 Solder tip can touch and press on the tip of Pin LEAD during the soldering

12.4.1.2 Recommended Soldering Conditions

Solder Type: Sn96.3~94-Ag3.3~4.3-Cu0.4~1.1

Maximum Solder Temperature: 370°C

Maximum Solder Time: 3s at the maximum temperature

Recommended Soldering Temp: 350±20°C

Typical Soldering Time: ≤3s

12.4.1.3 Solder Wetting

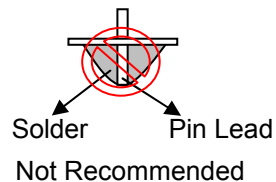
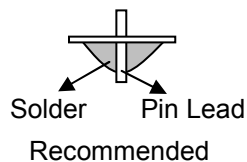

12.4.2 Pins of EL

12.4.2.1 Solder tip can touch and press on the tip of EL leads during soldering.

12.4.2.2 No Solder Paste on the soldering pad on the motherboard is recommended.

12.4.2.3 Recommended Soldering Conditions

Solder type: Nippon Alimit Leadfree SR-34, size 0.5mm

Recommended Solder Temperature: 270~290°C

Typical Soldering Time: ≤2s

Minimum solder distance from EL lamp (body):2.0mm

12.4.2.4 No horizontal press on the EL leads during soldering.

12.4.2.5 180° bend EL leads three times is not allowed.

12.4.2.6 Solder Wetting

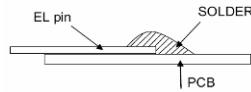

Recommended

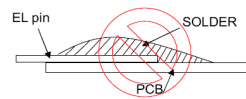

Not Recommended

12.4.2.7 The type of the solder iron:

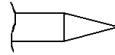

Recommended

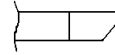

Not Recommended

12.4.2.8 Solder Pad

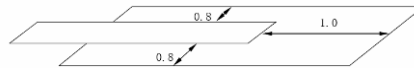

12.4 Operation

- 12.4.1 Do not drive LCD with DC voltage
- 12.4.2 Response time will increase below lower temperature
- 12.4.3 Display may change color with different temperature
- 12.4.4 Mechanical disturbance during operation, such as pressing on the display area, may cause the segments to appear "fractured".

12.5 Static Electricity

- 12.5.1 CMOS LSIs are equipped in this unit, so care must be taken to avoid the electro-static charge, by ground human body, etc.
- 12.5.2 The normal static prevention measures should be observed for work clothes and benches.
- 12.5.3 The module should be kept into anti-static bags or other containers resistant to static for storage.

12.6 Limited Warranty

- 12.7.1 Our warranty liability is limited to repair and/or replacement. We will not be responsible for any consequential loss.
- 12.7.2 If possible, we suggest customer to use up all modules in six months. If the module storage time over twelve months, we suggest that recheck it before the module be used.
- 12.7.3 After the product shipped, any product quality issues must be feedback within three months, otherwise, we will not be responsible for the subsequent or consequential events.

13. Packaging

TBD

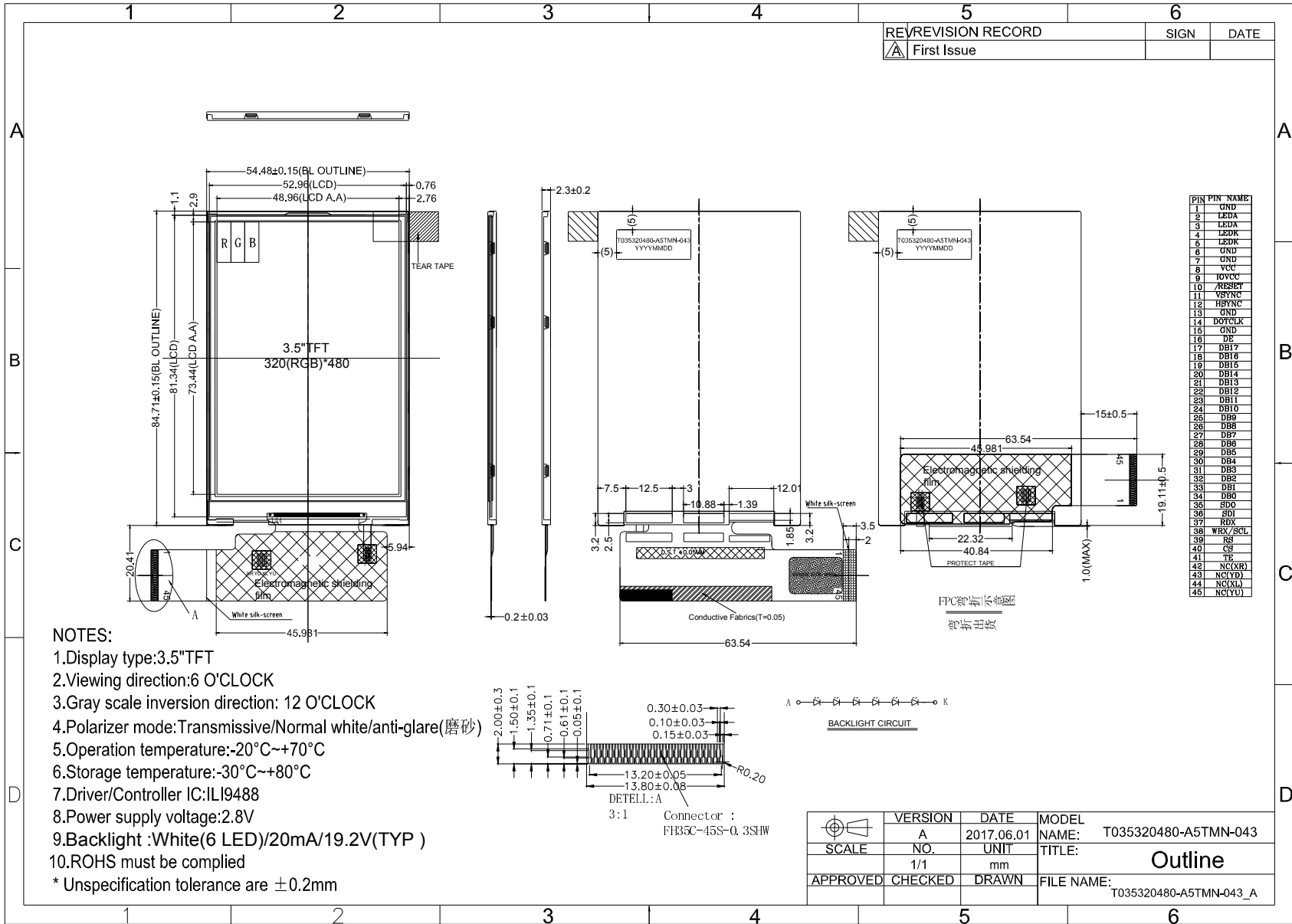

NOTES:

1. Display type: 3.5" TFT
 2. Viewing direction: 6 O'CLOCK
 3. Gray scale inversion direction: 12 O'CLOCK
 4. Polarizer mode: Transmissive/Normal white/anti-glare(磨砂)
 5. Operation temperature: -20°C~+70°C
 6. Storage temperature: -30°C~+80°C
 7. Driver/Controller IC: ILI9488
 8. Power supply voltage: 2.8V
 9. Backlight : White(6 LED)/20mA/19.2V(TYP)
 10. ROHS must be complied
- * Unspecification tolerance are ±0.2mm

REV	REVISION RECORD	SIGN	DATE
△	First Issue		

PIN	PIN NAME
1	GND
2	LEDA
3	LEDA
4	LEDA
6	LEDA
6	GND
7	GND
8	VCC
9	IOVCC
10	RESET
11	VSYN
12	HSYN
13	GND
14	DOTCLK
15	GND
16	DE
17	DB17
18	DB18
19	DB16
20	DB14
21	DB13
22	DB12
23	DB11
24	DB10
25	DB9
26	DB8
27	DB7
28	DB6
29	DB5
30	DB4
31	DB3
32	DB2
33	DB1
34	DB0
35	SIO
36	SIO
37	RDX
38	WRX/SCL
39	RS
40	CS
41	TE
42	NC(XR)
43	NC(YD)
44	NC(XL)
45	NC(YU)

VERSION	DATE	MODEL
A	2017.06.01	T035320480-A5TMN-043
SCALE	NO.	UNIT
1/1		mm
APPROVED	CHECKED	DRAWN
TITLE:		FILE NAME:
Outline		T035320480-A5TMN-043_A

14. Outline Drawing