

Version: 1.0

<p>TECHNICAL SPECIFICATION</p> <p>MODEL NO. : PM070WU2</p>
--

The content of this information is subject to be changed without notice.
Please contact PVI or its agent for further information

Customer' s Confirmation

Customer _____

Date _____

By _____

PVI' s Confirmation

Confirmed By

Prepared By

Revision History

Rev.	Issued Date	Revised Contents
0.1	Feb 17, 2009	Preliminary
0.2	Mar 24, 2009	Modify Page 10 8-2) Recommended Driving Condition for Back Light Modify Page 17 13. Optical Characteristics: Contrast Ratio & Viewing Angle data Add Page 17 13. Optical Characteristics: Brightness data Add Page 22 17. Packing Diagram
1.0	Apr 27, 2009	Add Page 13 11. Block Diagram Modify Page 14 12. Interface Timing Modify Page 8 6-2) Electrical Performances: Operation Force from 50g to 80g

TECHNICAL SPECIFICATION***CONTENTS***

<i>NO.</i>	<i>ITEM</i>	<i>PAGE</i>
-	Cover	1
	Revision History	2
-	Contents	3
1	Application	4
2	Features	4
3	Mechanical Specifications	4
4	Mechanical Drawing of TFT-LCD module	5
5	Input Terminals	7
6	Touch Panel Characteristics	8
7	Absolute Maximum Ratings	10
8	Electrical Characteristics	10
9	Pixel Arrangement	11
10	Display Color and Gray Scale Reference	12
11	Block Diagram	13
12	Interface Timing	14
13	Power On Sequence	17
14	Optical Characteristics	17
15	Handling Cautions	20
16	Reliability Test	21
17	Packing Diagram	22

1. Application

This data sheet applies to a color TFT LCD module, PM070WU2. The application of panel are OA product, which requires high quality flat panel display.

Prime View assumes no responsibility for any damage resulting from the use of the device which does not comply with the instructions and the precautions in these specification sheets.

2. Features

- . Wide VGA (800*480 pixels) resolution
- . Amorphous silicon TFT LCD panel with LED back-light unit
- . Pixel in stripe configuration
- . Thin and light weight
- . Display Colors : 262,144 colors
- . +3.3V DC supply voltage for TFT LCD panel driving
- . Wide viewing angle
- . TTL transmission interface
- . Module with resistive type touch panel.

3. Mechanical Specifications

Parameter	Specifications	Unit
Screen Size	7.0(diagonal)	inch
Display Format	800×(R, G, B)×480	dot
Display Colors	262,144	
Active Area	152.4(H)×91.44(V)	mm
Pixel Pitch	0.1905(H)×0.1905(V)	mm
Pixel Configuration	Stripe	
Outline Dimension	166.3(W)×106.8 (H)× 11.50(D) (typ.)	mm
Weight	300±15	g
Back-light	33-LED	
Surface treatment	Anti-glare and EWV Film	
Display mode	Normally white	
Surface treatment of Touch Panel	3H	
Gray scale inversion direction	6 o' clock	Note 14-1

4. Mechanical Drawing of TFT-LCD Module

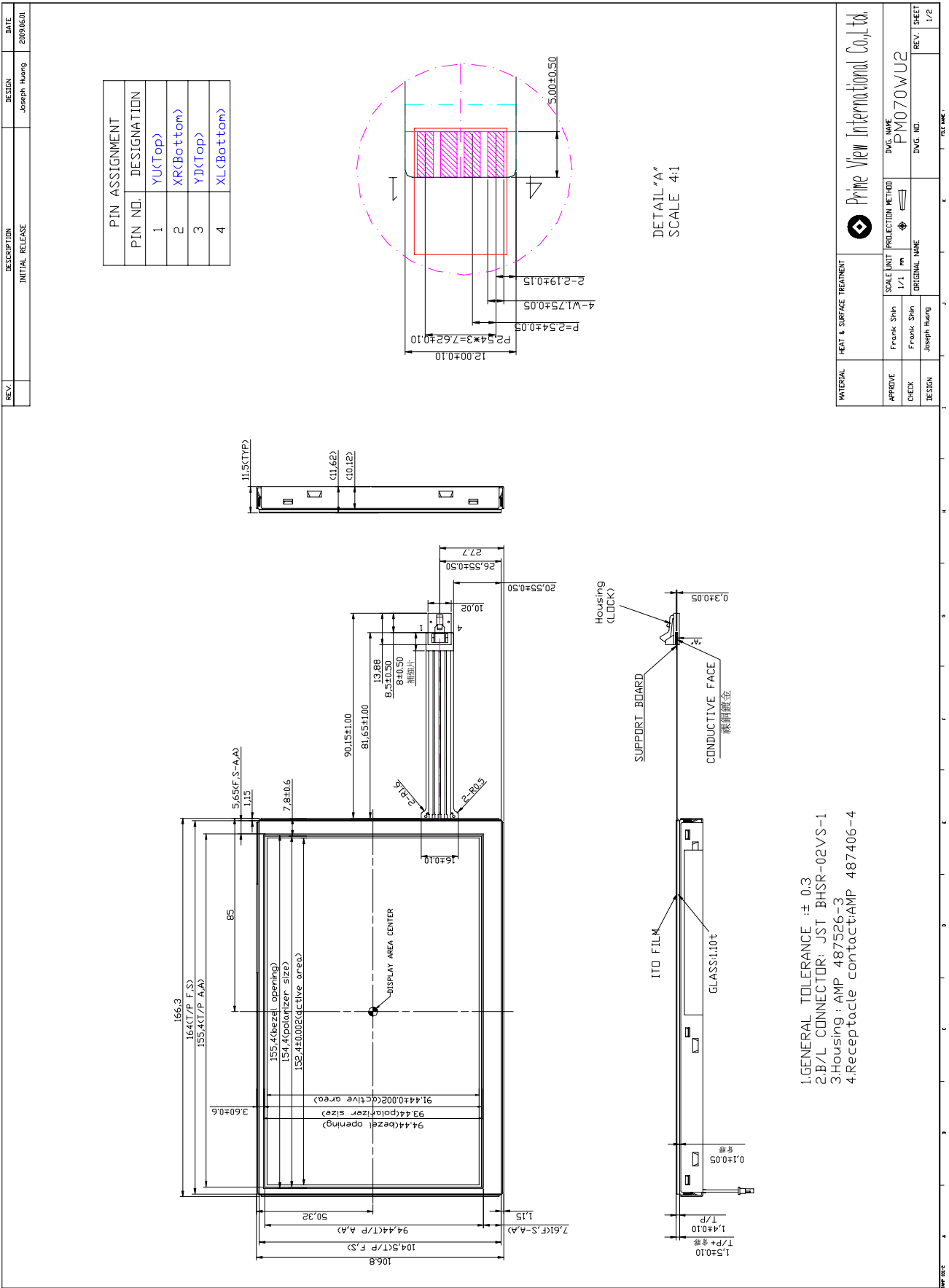

PM070WU2

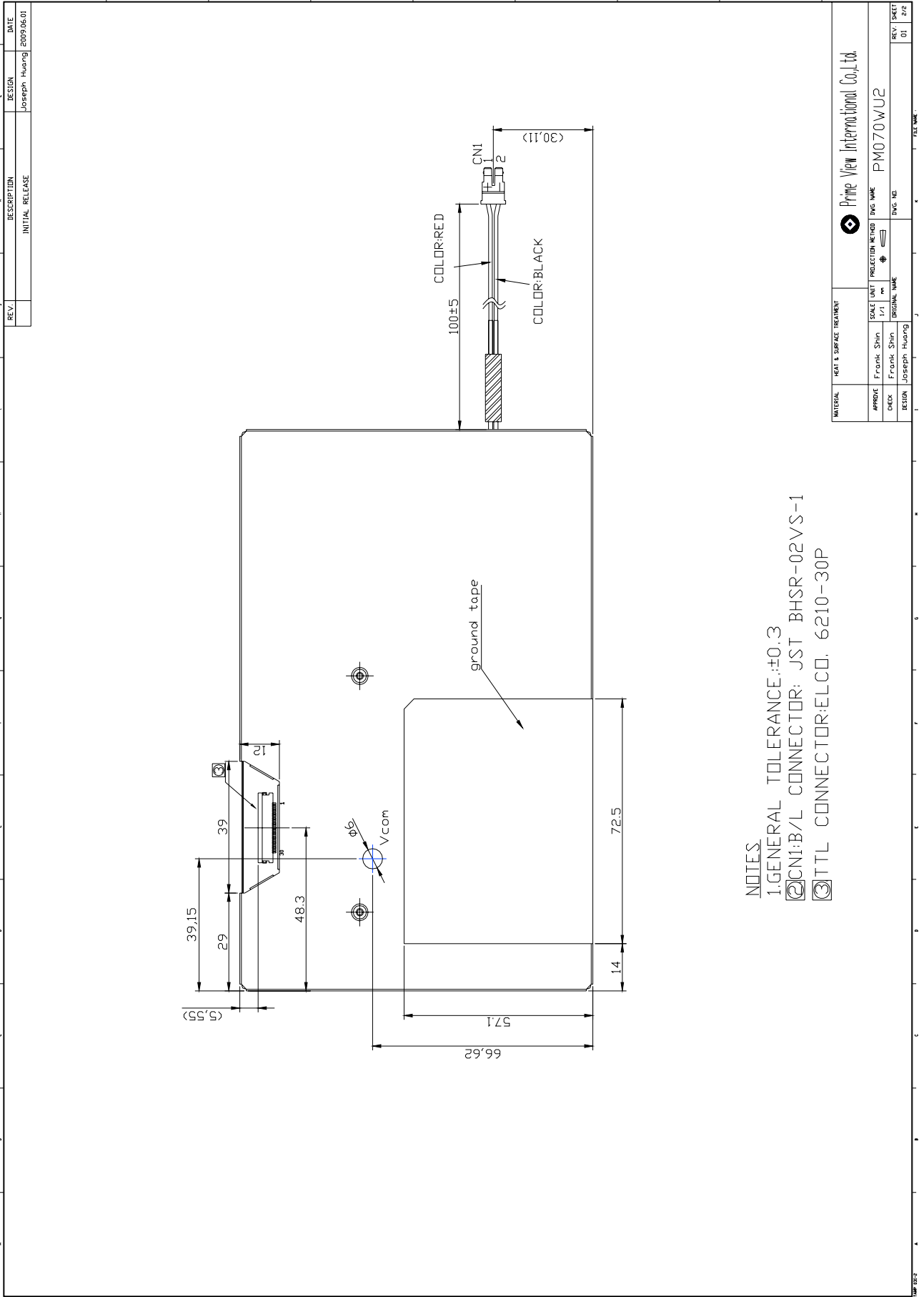

5. Input Terminals

5-1) TFT-LCD Panel Driving

Connector type: ELCO 6210-30P

Pin No.	Symbol	Function	Remark
1	CLK	Clock Signal for Sampling Image Digital Data	
2	Hsync	Horizontal Synchronous Signal	
3	Vsync	Vertical Synchronous Signal	
4	GND	Ground (0V)	
5	R0	Red Image Data Signal (LSB)	
6	R1	Red Image Data Signal	
7	R2	Red Image Data Signal	
8	R3	Red Image Data Signal	
9	R4	Red Image Data Signal	
10	R5	Red Image Data Signal (MSB)	
11	GND	Ground (0V)	
12	G0	Green Image Data Signal (LSB)	
13	G1	Green Image Data Signal	
14	G2	Green Image Data Signal	
15	G3	Green Image Data Signal	
16	G4	Green Image Data Signal	
17	G5	Green Image Data Signal (MSB)	
18	GND	Ground (0V)	
19	B0	Blue Image Data Signal (LSB)	
20	B1	Blue Image Data Signal	
21	B2	Blue Image Data Signal	
22	B3	Blue Image Data Signal	
23	B4	Blue Image Data Signal	
24	B5	Blue Image Data Signal (MSB)	
25	GND	Ground (0V)	
26	DENB	Compound Synchronization signal	Note5-1
27	VCC	DC +3.3V Power Supply	
28	VCC	DC +3.3V Power Supply	
29	R/L	Left / Right control for source driver	Note5-2
30	U/D	Up / Down control for gate driver	Note5-2

Note5-1: DENB input signal.

If customer wanted to off the DENB mode, you must keep the DENB always High or Low.

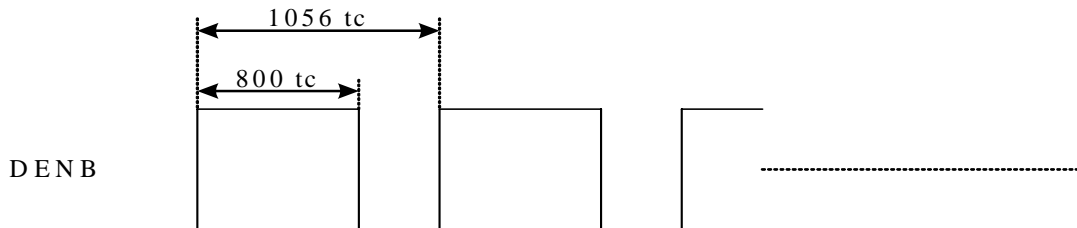

(tc: the period of sampling clock)

Note 5-2: The definitions of U/D & R/L

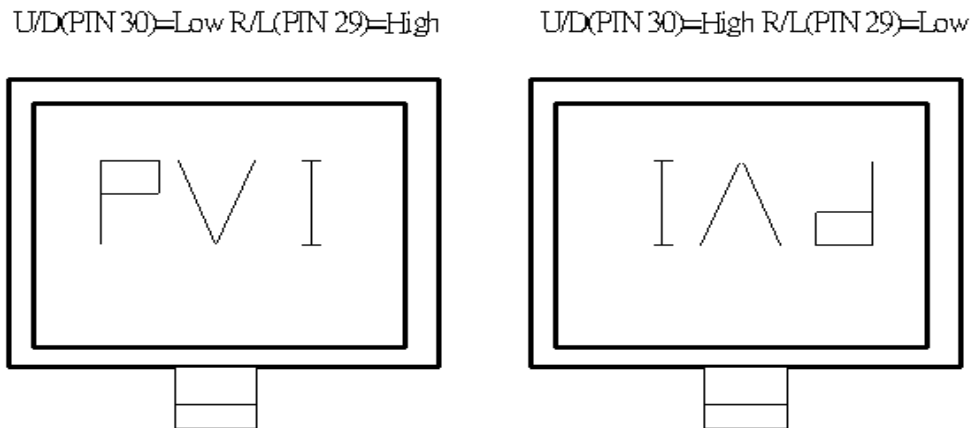

6. Touch Panel Characteristics

6-1) Pin assignment

Pin No.	Symbol	Function	Remark
1	YU	Upper electrode Y(Upper side)	
2	XR	Lower electrode X(Right side)	
3	YD	Upper electrode Y(Down side)	
4	XL	Lower electrode X(Left side)	

6-2) Electrical Performances

Parameters	Symbol	MIN.	Typ.	MAX.	Unit	Remark
Terminal Resistance	X	550	800	1025	Ω	
	Y	200	300	420	Ω	
Input Voltage	VT	-	5.0	7.0	V	
Linearity(X ,Y direction)		-	-	± 1.5	%	
Insulation Impedance		20	-	-	M Ω	DC=25V
Response Time		-	-	15	ms	
Operation Force		-	-	80	g	Note 6 - 1

Note 6-1: Input through 0.8R stylus or R8.0mm finger.

6-3) Durability Performances

1. Hitting Durability:

At least 1,000,000 times with R8.0mm silicon rubber, 250g, 3times/sec.

2. Sliding Durability:

At least 100,000 times with R0.8mm placental stylus, 250g, 60mm/sec.

6-4) Integration Design Guide

Avoid the design that Front-case overlap and press on the active area of the touch-panel.
 Give enough gap (over 0.5mm at compressed) between the front case and touch-panel to protect wrong operating.

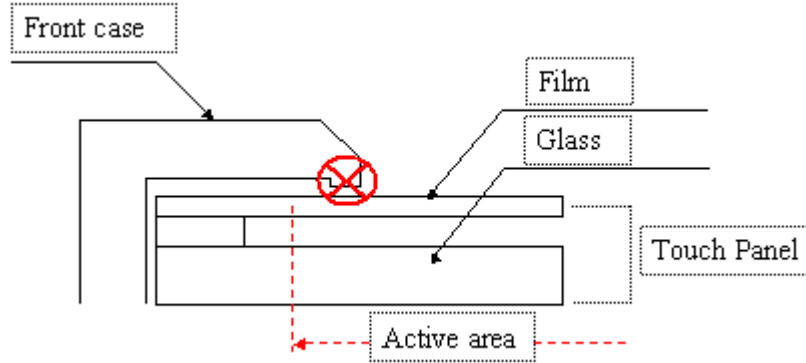

Use a buffer material (Gasket) between the touch-panel and front-case to protect damage and wrong operating.

Avoid the design that buffer material overlap and press on the inside of touch-panel viewing area.

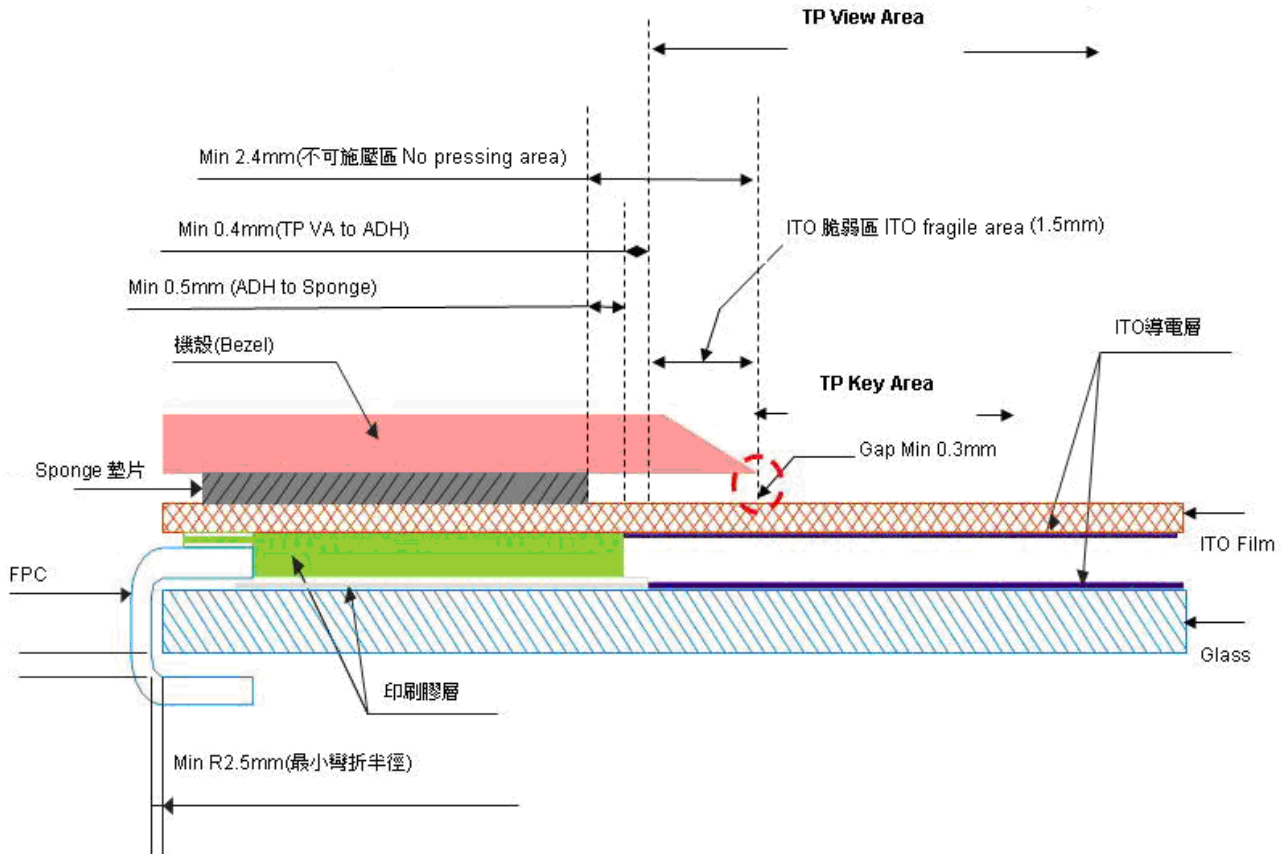

Note: We strongly suggest to follow above design guide to avoid the linear defect happened on the touch panel.

7. Absolute Maximum Ratings:

GND=0V, Ta=25°C

Parameters	Symbol	MIN.	MAX.	Unit	Remark
Supply Voltage	V _{CC}	-0.3	+4.0	V	
Input Signals Voltage	V _{IN}	-0.3	V _{CC} +0.3	V	
Storage Temperature	T _{st}	-30	+80	°C	
Operation Temperature	T _{op}	-20	+70	°C	

8. Electrical Characteristics

8-1) Recommended Operating Conditions:

GND = 0V · Ta = 25°C

Item	Symbol	Min.	Typ.	Max.	Unit	Remark
Supply Voltage	V _{CC}	3.0	3.3	3.6	V	
Current Dissipation	I _{CC}	-	110	165	mA	Note8-1
Total power consumption	P _{CC}	-	363	544.5	mW	V _{CC} =3.3V
Digital input voltage	High Level	V _{IN}	0.7 V _{CC}	-	V _{CC}	mV
	Low Level	V _{IL}	-0.1	-	0.2V _{CC}	

Note 8-1: To test the current dissipation of VCC using the “color bars” testing pattern shown as below

1	2	3	4	5	6	7	8
---	---	---	---	---	---	---	---

1. White
2. Yellow
3. Cyan
4. Green
5. Magenta
6. Red
7. Blue
8. Black

I_{CC} current dissipation testing pattern

8-2) Recommended Driving Condition for Back Light

Ta = 25°C

Parameter	Symbol	Min	TYP	MAX	Unit	Remark
Supply voltage of LED backlight	V _{LED1-11}	-	-	(11)	V	Note 8-2
Supply current of LED backlight	I _{LED1-11}	-	16	-	mA	Note 8 - 3
Backlight Power Consumption	P _{LED}	-	-	1.94	W	Note 8-2 /Note 8-4

Note 8-2: I_{LED}= 16mA, constant current

Note 8-3: The LED driving condition is defined for each LED module. (3 LED Serial)

$$\text{Input current} = 16\text{mA} * 11 = 176\text{mA}$$

Note 8-4: P_{LED} = V_{LED1} * I_{LED1} + V_{LED2} * I_{LED2}····· + V_{LED10} * I_{LED10}+V_{LED11} * I_{LED11}

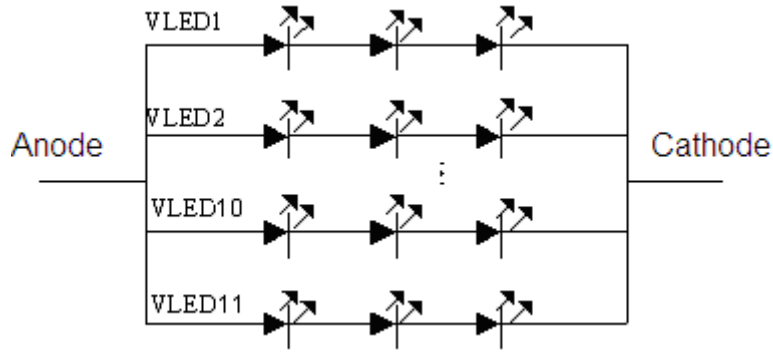

8-3) Backlight driving

Connector type: JST BHSR-02VS-1N, PIN No 2 pin

Pin No	Symbol	Description	Remark
1	+	Input terminal (Anode)	Wire color : Red
2	-	Input terminal (Cathode)	Wire Color : Black

9. Pixel Arrangement

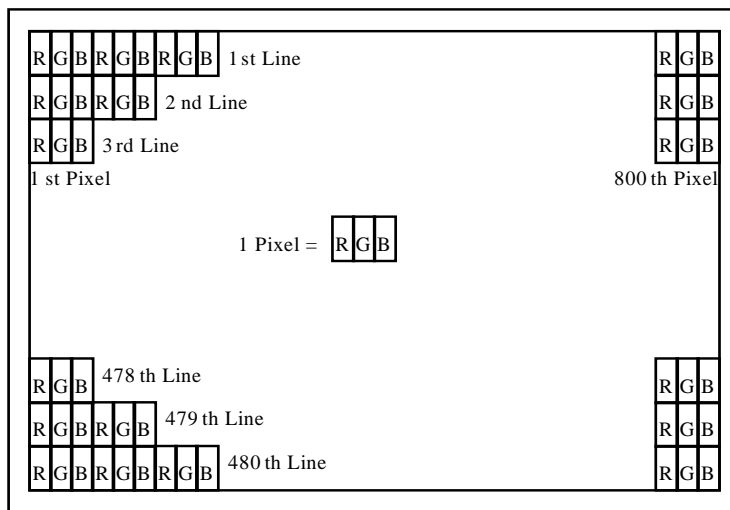

10. Display Color and Gray Scale Reference

Color		Input Color Data																	
		Red						Green						Blue					
		R5	R4	R3	R2	R1	R0	G5	G4	G3	G2	G1	G0	B5	B4	B3	B2	B1	B0
Basic Colors	Black	0	0	0	0	0	0	0	0	0	0	0	0	0	0	0	0	0	0
	Red (63)	1	1	1	1	1	1	0	0	0	0	0	0	0	0	0	0	0	0
	Green (63)	0	0	0	0	0	0	1	1	1	1	1	1	0	0	0	0	0	0
	Blue (63)	0	0	0	0	0	0	0	0	0	0	0	0	1	1	1	1	1	1
	Cyan	0	0	0	0	0	0	1	1	1	1	1	1	1	1	1	1	1	1
	Magenta	1	1	1	1	1	1	0	0	0	0	0	0	1	1	1	1	1	1
	Yellow	1	1	1	1	1	1	1	1	1	1	1	1	0	0	0	0	0	0
	White	1	1	1	1	1	1	1	1	1	1	1	1	1	1	1	1	1	1
Red	Red (00)	0	0	0	0	0	0	0	0	0	0	0	0	0	0	0	0	0	0
	Red (01)	0	0	0	0	0	1	0	0	0	0	0	0	0	0	0	0	0	0
	Red (02)	0	0	0	0	1	0	0	0	0	0	0	0	0	0	0	0	0	0
	Darker																		
	↓	↓	↓	↓	↓	↓	↓	↓	↓	↓	↓	↓	↓	↓	↓	↓	↓	↓	↓
	Brighter																		
	Red (61)	1	1	1	1	0	1	0	0	0	0	0	0	0	0	0	0	0	0
	Red (62)	1	1	1	1	1	0	0	0	0	0	0	0	0	0	0	0	0	0
Red (63)	1	1	1	1	1	1	0	0	0	0	0	0	0	0	0	0	0	0	
Green	Green (00)	0	0	0	0	0	0	0	0	0	0	0	0	0	0	0	0	0	0
	Green (01)	0	0	0	0	0	0	0	0	0	0	0	1	0	0	0	0	0	0
	Green (02)	0	0	0	0	0	0	0	0	0	0	1	0	0	0	0	0	0	0
	Darker																		
	↓	↓	↓	↓	↓	↓	↓	↓	↓	↓	↓	↓	↓	↓	↓	↓	↓	↓	↓
	Brighter																		
	Green (61)	0	0	0	0	0	0	1	1	1	1	0	1	0	0	0	0	0	0
	Green (62)	0	0	0	0	0	0	1	1	1	1	1	0	0	0	0	0	0	0
Green (63)	0	0	0	0	0	0	1	1	1	1	1	1	0	0	0	0	0	0	
Blue	Blue (00)	0	0	0	0	0	0	0	0	0	0	0	0	0	0	0	0	0	0
	Blue (01)	0	0	0	0	0	0	0	0	0	0	0	0	0	0	0	0	0	1
	Blue (02)	0	0	0	0	0	0	0	0	0	0	0	0	0	0	0	0	1	0
	Darker																		
	↓	↓	↓	↓	↓	↓	↓	↓	↓	↓	↓	↓	↓	↓	↓	↓	↓	↓	↓
	Brighter																		
	Blue (61)	0	0	0	0	0	0	0	0	0	0	0	0	1	1	1	1	0	1
	Blue (62)	0	0	0	0	0	0	0	0	0	0	0	0	1	1	1	1	1	0
Blue (63)	0	0	0	0	0	0	0	0	0	0	0	0	1	1	1	1	1	1	

11. Block Diagram

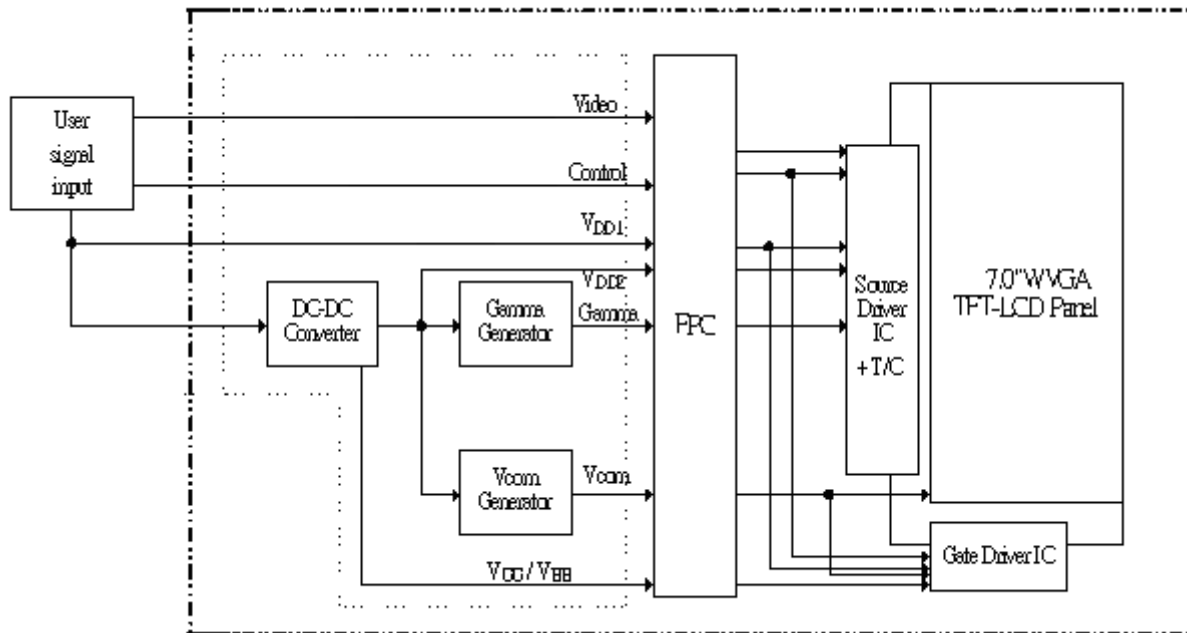

12. Interface Timing

12-1) Timing Parameters

		Symbol	Min.	Typ.	Max.	Unit	Remark	
Power supply		VCC	3.0	3.3	3.6	V		
CLK	Frequency	1/tc	-	32	-	MHz		
		tc	-	31.25	-	ns		
HSYNC	Period	Hp	-	33	-	us		
			-	1056	-	tc		
	Display period	Hdp	-	800	-	tc		
	Pulse width	Hpw	-	128	-	tc		
	Back-porch	Hbp	-	88	-	tc		
	Front-porch	Hfp	-	40	-	tc		
	Hpw+Hbp			-	216	-	tc	
	Hsync-CLK	Hhc	10	-	Tc-10	ns		
Vsync-Hsync	Hvh	0	0	200	tc			
VSYNC	Period	Vp	-	17.325	-	ms		
			-	525	-	Hp		
	Display period	Vdp	-	480	-	Hp		
	Pulse width	Vpw	-	2	-	Hp		
	Back-porch	Vbp	-	33	-	Hp		
	Front-porch	Vfp	-	10	-	Hp		
Vpw+Vbp			-	35	-	Hp		
DENB	Horizontal scanning period	T1	860	1056	1064	tc		
	Horizontal display period	T2	-	800	-	tc		
	Vertical display period	T3	-	480	-	T1		
	Frame cycling period	T4	490	525	590	T1		
R,G,B	CLK-DATA	Dcd	10	-	-	ns		
	DATA-CLK	Ddc	8	-	-	ns		

12-2) The Timing Diagram

A. The timing chart for DENB mode

a) CLK data, relationship

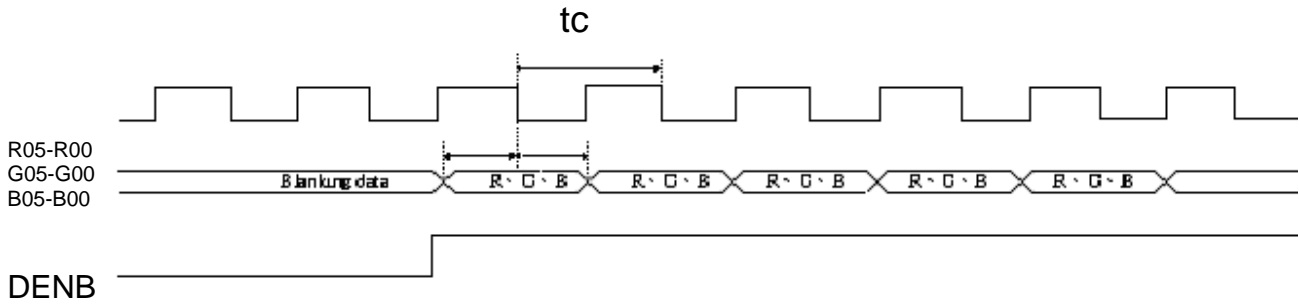

b) DENB Timing

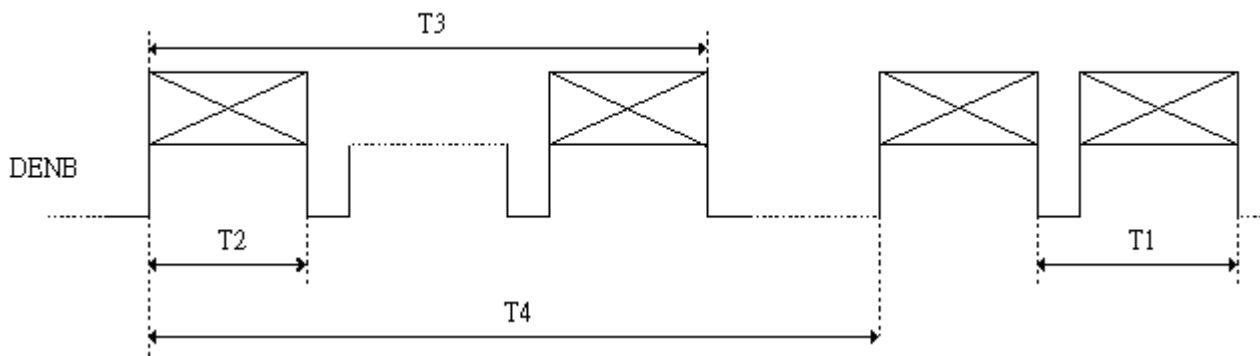

B. The timing chart for sync mode

a) CLK Hsync relation ship



b) Hsync timing

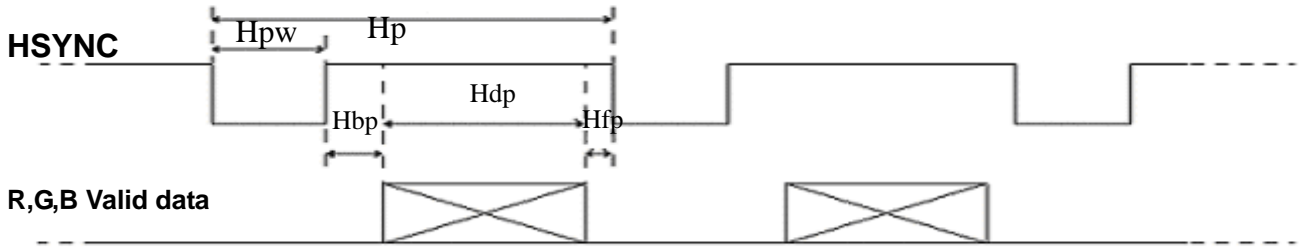

c) Hsync,Vsync relation ship

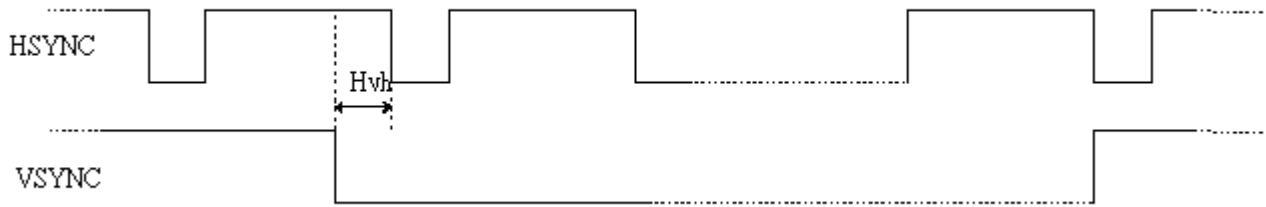

d) Vsync Timing

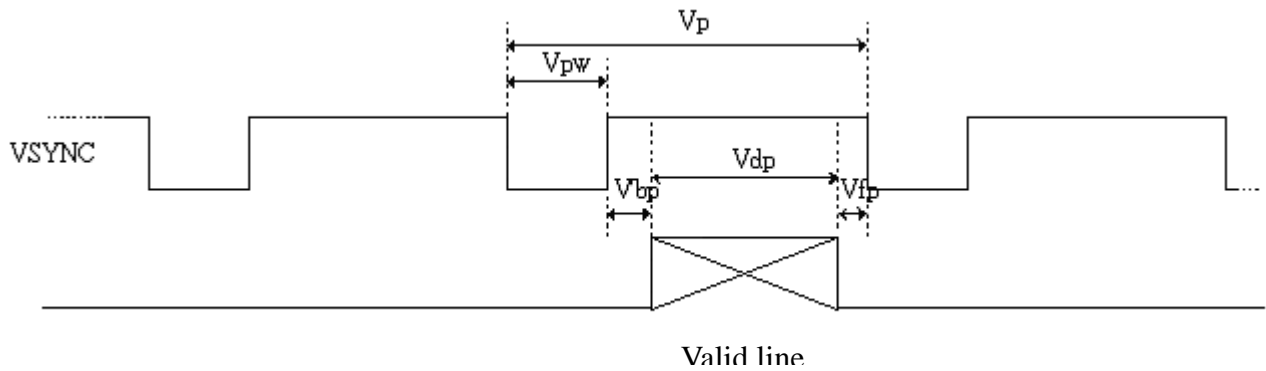

13. Power on Sequence

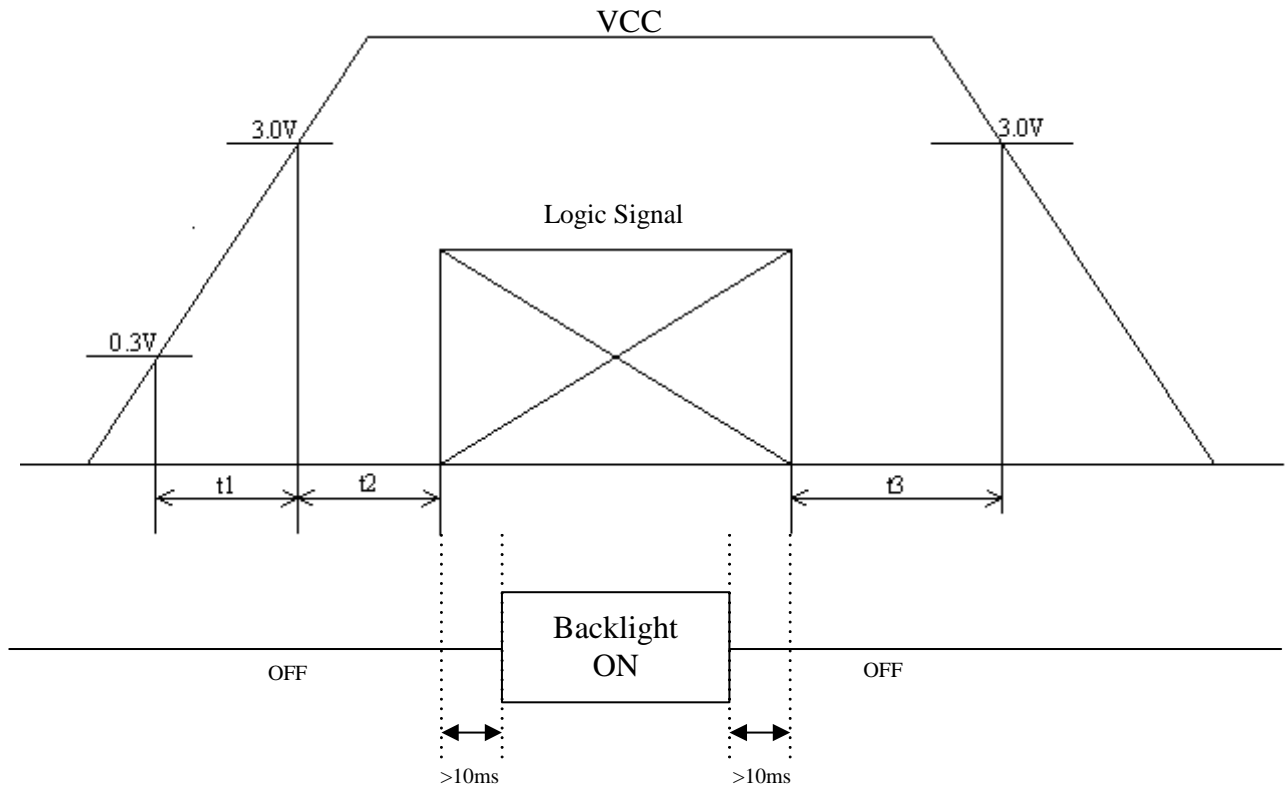

1. $0 < t_1 \leq 20\text{ms}$
2. $0 < t_2 \leq 50\text{ms}$
3. $0 < t_3 \leq 1\text{s}$

14. Optical Characteristics

14-1) Specification:

 $T_a = 25^\circ\text{C}$

Parameter		Symbol	Condition	MIN.	TYP.	MAX.	Unit	Remarks
Viewing Angle	Horizontal	$\theta_{22.21}$	$CR \geq 10$	± 75	± 80	-	deg	Note 14-1
	Vertical	θ_{12}		55	60	-	deg	
		θ_{11}		65	70	-	deg	
Contrast Ratio		CR	$\theta = 0^\circ$	400	600	-	-	Note 14-2
Response time	Rise	T_r	$\theta = 0^\circ$	-	5	10	ms	Note 14-3
	Fall	T_f		-	15	20	ms	
Brightness		L	$\theta = 0^\circ / \varphi = 0$	300	330	-	cd/m^2	
LED Life Time			25°C	20000	30000	-	hrs	Note 14-4
Luminance Uniformity		U	-	70	75	-	%	Note 14-5
White Chromaticity		x	$\theta = 0^\circ / \varphi = 0$	0.27	0.31	0.35	-	
		y		0.29	0.33	0.37	-	
Cross Talk		-	$\theta = 0^\circ$	-	-	3.5	%	Note 14-6

Note 14-1: The definitions of viewing angles are as follow.

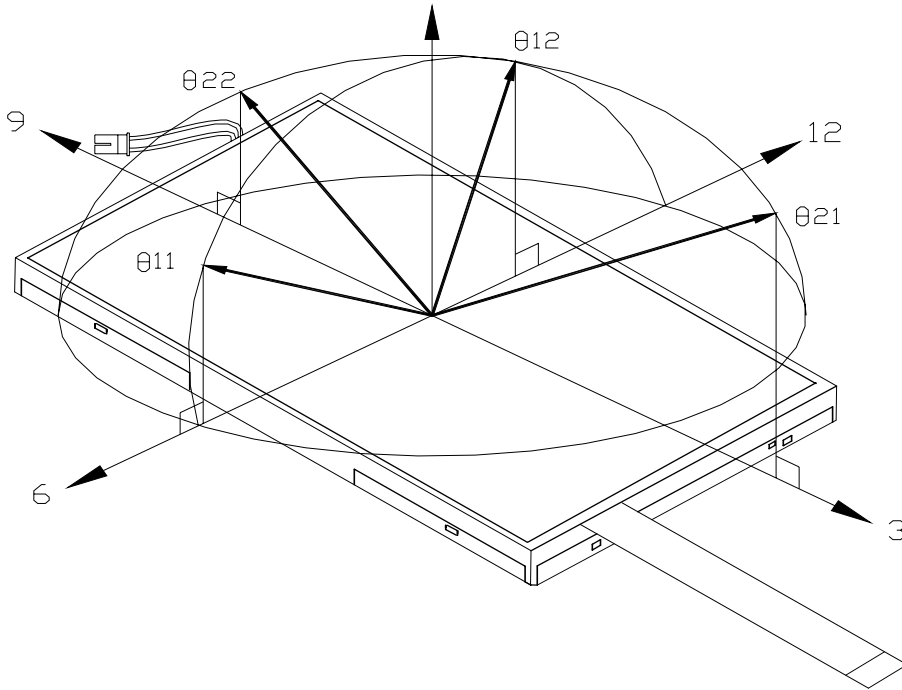

Note 14-2: The definition of contrast ratio $CR = \frac{\text{Luminance when Testing point is White}}{\text{Luminance when Testing point is Black}}$

Note 14-3: Definition of Response Time T_r and T_f :

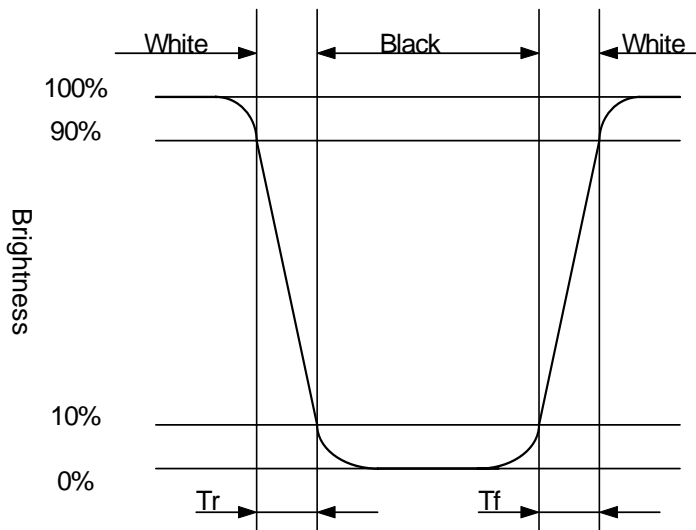

Note 14-4: The “LED Life time “ is defined as the module brightness decrease to 50% original Brightness that the ambient temperature is 25°C and $I_{LED} = 176mA$

Note 14-5: The uniformity of LCD is defined as

$$U = \frac{\text{The Minimum Brightness of the 9 testing Points}}{\text{The Maximum Brightness of the 9 testing Points}}$$

Luminance meter : BM-5A or BM-7 fast(TOPCON)

Measurement distance : 500 mm +/- 50 mm

Ambient illumination : < 1 Lux

Measuring direction : Perpendicular to the surface of module

The test pattern is white (Gray Level 63).

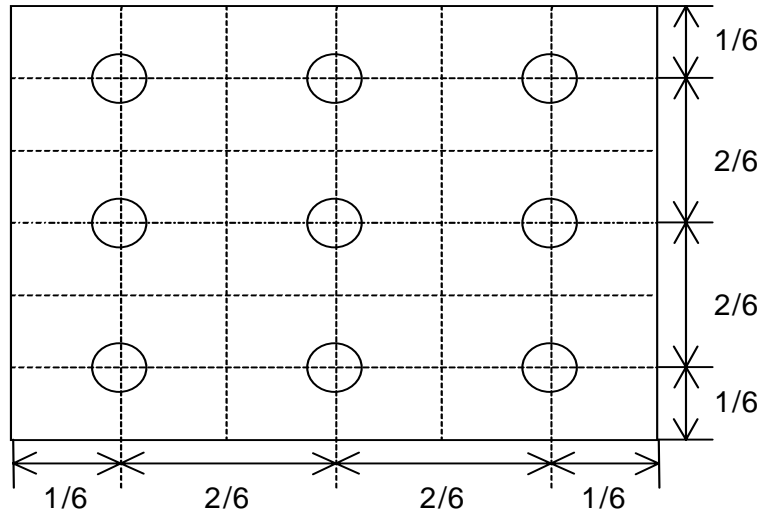

Note 14-6: Cross Talk (CTK) = $\frac{|YA-YB|}{YA} \times 100\%$

YA: Brightness of Pattern A

YB: Brightness of Pattern B

Luminance meter : BM 5A or BM-7 fast (TOPCON)

Measurement distance : 500 mm +/- 50 mm

Ambient illumination : < 1 Lux

Measuring direction : Perpendicular to the surface of module

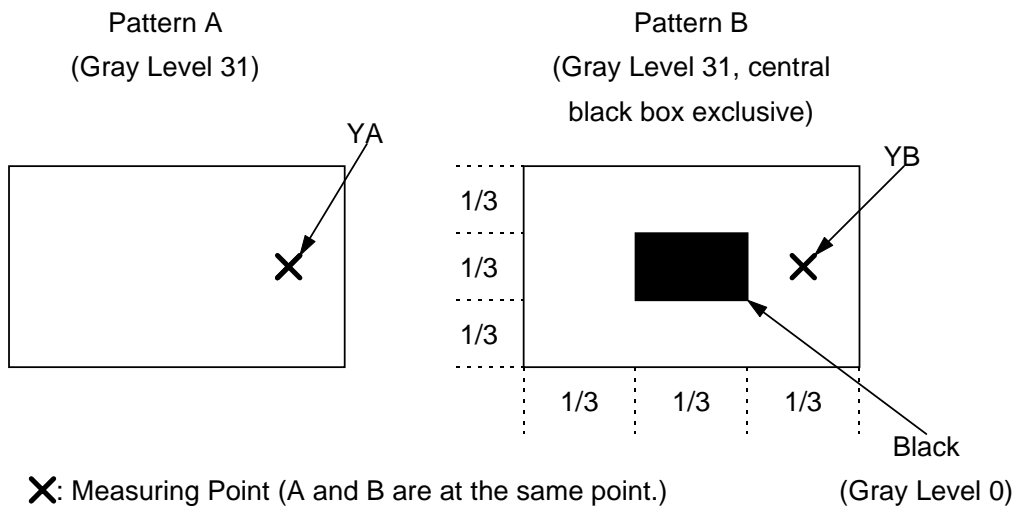

15. Handling Cautions

15-1) Mounting of module

- a) Please power off the module when you connect the input/output connector.
- b) Polarizer which is made of soft material and susceptible to flaw must be handled carefully.
- c) Protective film (Laminator) is applied on surface to protect it against scratches and dirt.
- d) Please following the tear off direction as figure15-1 to remove the protective film as slowly as possible, so that electrostatic charge can be minimized.

15-2) Precautions in mounting

- a) When metal part of the TFT-LCD module (shielding lid and rear case) is soiled, wipe it with soft dry cloth.
- b) Wipe off water drops or finger grease immediately. Long contact with water may cause discoloration or spots.
- c) TFT-LCD module uses glass which breaks or cracks easily if dropped or bumped on hard surface. Please handle with care.
- d) Since CMOS LSI is used in the module. So take care of static electricity and earth yourself when handling.

15-3) Adjusting module

- a) Adjusting volumes on the rear face of the module have been set optimally before shipment.
- b) Therefore, do not change any adjusted values. If adjusted values are changed, the specifications described may not be satisfied.

15-4) Others

- a) Do not expose the module to direct sunlight or intensive ultraviolet rays for many hours.
- b) Store the module at a room temperature place.
- c) The voltage of beginning electric discharge may over the normal voltage because of leakage current from approach conductor by to draw lump read lead line around.
- d) If LCD panel breaks, it is possibly that the liquid crystal escapes from the panel. Avoid putting it into eyes or mouth. When liquid crystal sticks on hands, clothes or feet. Wash it out immediately with soap.
- e) Observe all other precautionary requirements in handling general electronic components.
- f) Please adjust the voltage of common electrode as material of attachment by 1 module.

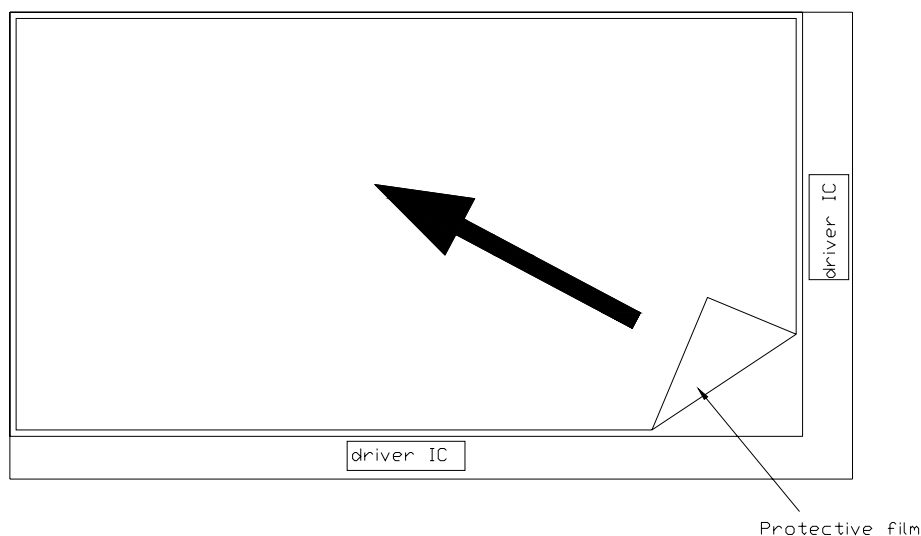

Figure 15-1 the way to peel off protective film

16. Reliability Test

No	Test Item	Test Condition
1	High Temperature Storage Test	Ta = +80°C, 240 hrs
2	Low Temperature Storage Test	Ta = -30°C, 240 hrs
3	High Temperature Operation Test	Ta = +70°C, 240 hrs
4	Low Temperature Operation Test	Ta = -20°C, 240 hrs
5	High Temperature & High Humidity Operation Test	Ta = +60°C, 90%RH, 240 hrs (No Condensation)
6	Thermal Cycling Test (non-operating)	-30°C → +80°C, 100 Cycles 30min 30min
7	Vibration Test (non-operating)	Frequency : 10 ~ 55 Hz, Amplitude : 1 mm Sweep time: 11 min Test Period: 6 Cycles for each direction of X, Y, Z
8	Shock Test (non-operating)	100G, 6ms Direction: ±X, ±Y, ±Z Cycle: 3 times
9	Electrostatic Discharge Test (Operating)	C=150pF. R=330Ω. Contact=±8KV ; Air=±15KV 10times/point, 5 points/panel face

Ta: ambient temperature

Note: The protective film must be removed before temperature test.

[Criteria]

In the standard conditions, there is not display function NG issue occurred. (Including: line defect ,no image), All the cosmetic specification is judged before the reliability stress.

17. Packing Diagram

