

Revision History

Rev.	Issued Date	Revised Contents	Remark
1.0	Dec.22,2006	Release version	
2.0	Apr.17,2007	Modify Block Diagram	
3.0	March.24.2008	Add Page 21 14.Handling Cautions 14-1 item e)	
4.0	Jan.28, 2010	Modify Page 5 4. Mechanical Drawing of TFT-LCD module Add Ground Tape	

TECHNICAL SPECIFICATION

CONTENTS

NO.	ITEM	PAGE
-	Cover	1
-	Revision History	2
-	Contents	3
1	Application	4
2	Features	4
3	Mechanical Specifications	4
4	Mechanical Drawing of TFT-LCD module	5
5	Input Terminals	7
6	Absolute Maximum Ratings	9
7	Electrical Characteristics	9
8	Pixel Arrangement	11
9	Display Color and Gray Scale Reference	12
10	Block Diagram	13
11	Interface Timing	14
12	Power On Sequence	17
13	Optical Characteristics	17
14	Handling Cautions	21
15	Reliability Test	23
16	Packing Diagram	24

1.Application

This data sheet applies to a color TFT LCD module, PM070WL3.

The application of panel are OA product, portable DVD, car TV(must use Analog to Digital driving board), which requires high quality flat panel display.

Prime View assume no responsibility for any damage resulting from the use of the device which dose not comply with the instructions and the precautions in these specification sheet.

2. Features

- . Wide VGA (800*480 pixels) resolution
- . Amorphous silicon TFT LCD panel with LED back-light unit
- . Pixel in stripe configuration
- . Thin and light weight
- . Display Colors : 262,144 colors
- . 3.3V LVDS interface standard: THC63LVDF64A as receiver
- . +3.3V DC supply voltage for TFT LCD panel driving
- . Wide viewing angle

3.Mechanical Specifications

Parameter	Specifications	Unit
Screen Size	7.0(diagonal)	inch
Display Format	800×(R, G, B)×480	dot
Display Colors	262,144	
Active Area	152.4(H)×91.44(V)	mm
Pixel Pitch	0.1905(H)×0.1905(V)	mm
Pixel Configuration	Stripe	
Outline Dimension	166.3(W)×105.3 (H)×10.7 (typ.) (D)	mm
Weight	265±10	g
LED Back-light	33-LED	
Surface treatment	Anti-glare and Wide View Film	
Display mode	Normally white	
Gray scale inversion direction	6 o'clock [ref to Note 13-1]	

4.Mechanical Drawing of TFT-LCD Module
Outline Drawing : Front View (unit mm)

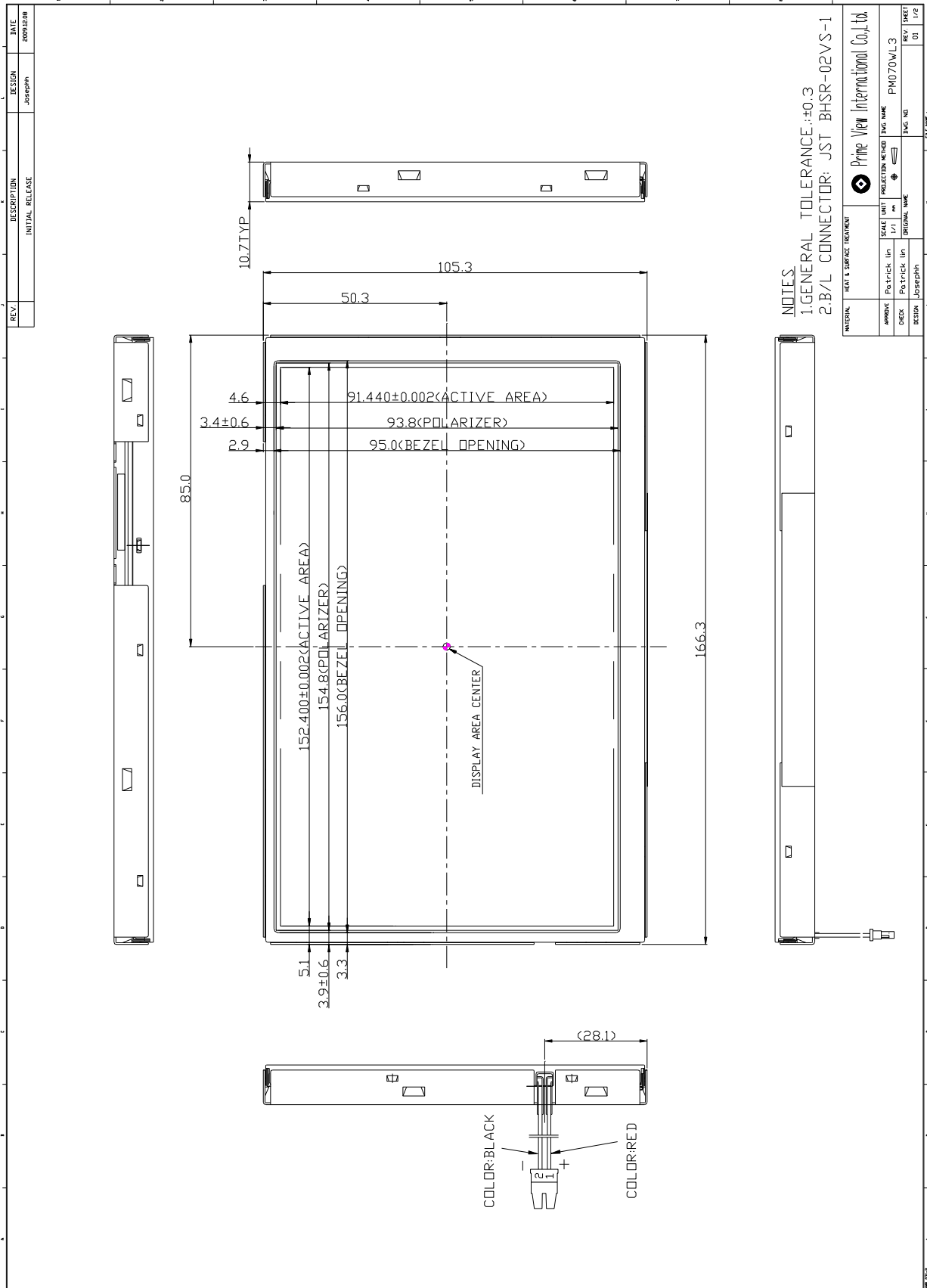

Outline Drawing : Rear View (unit mm)

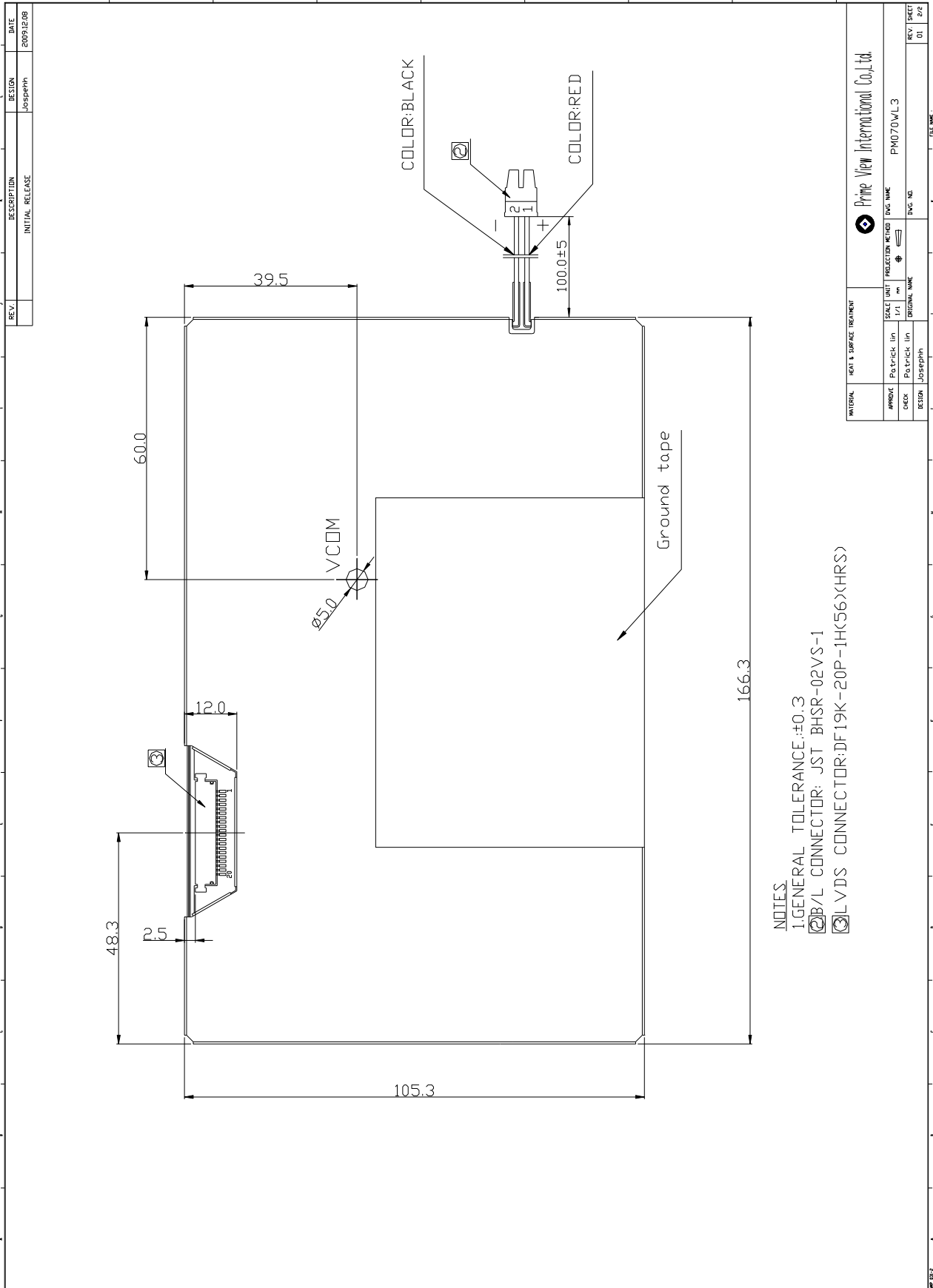

5. Input Terminals

5-1) TFT-LCD Panel Driving

Connector type: DF19K-20P-1H (56)(HRS)

Pin No.	Symbol	Function	Remark
1	Vcc	+3.3V Power Supply	
2	Vcc	+3.3V Power Supply	
3	GND	Ground	
4	GND	Ground	
5	INO-	LVDS receiver signal channel 0	
6	INO+	LVDS receiver signal channel 0	
7	GND	Ground	
8	IN1-	LVDS receiver signal channel 1	
9	IN1+	LVDS receiver signal channel 1	
10	GND	Ground	
11	IN2-	LVDS receiver signal channel 2	
12	IN2+	LVDS receiver signal channel 2	
13	GND	Ground	
14	CLK-	LVDS receiver signal clock	
15	CLK+	LVDS receiver signal clock	
16	GND	Ground	
17	NC	No connection	
18	NC	No connection	
19	GND	Ground	
20	GND	Ground	

LVDS Interface Block Diagram

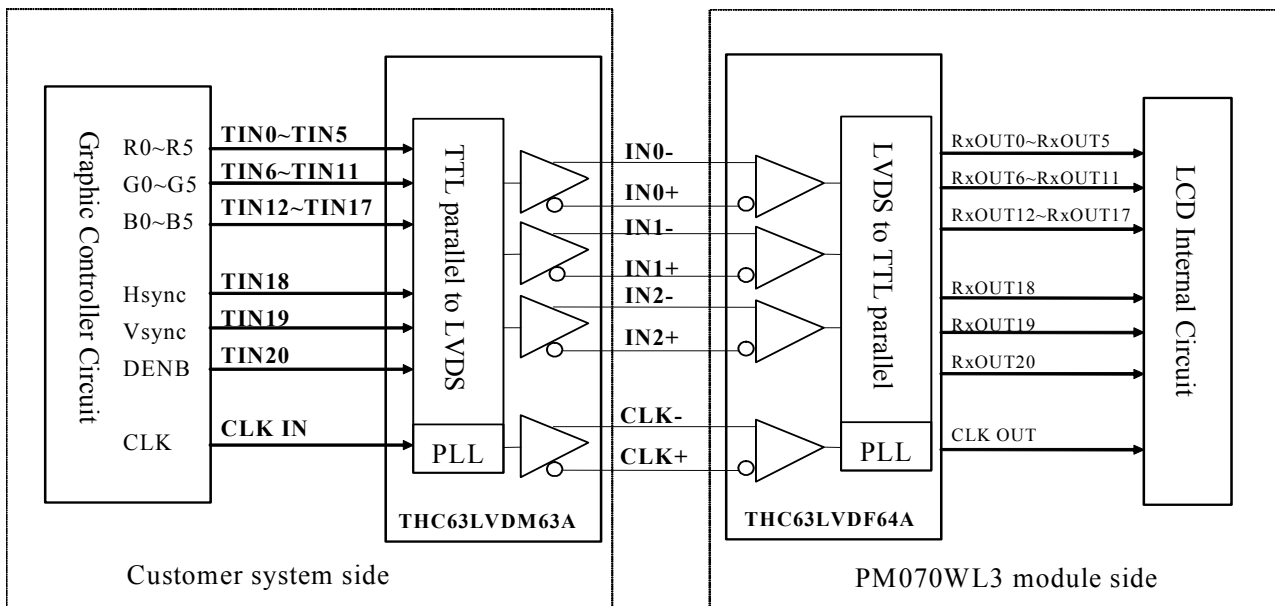

Recommended Transmitter (THC63LVDM63A Thine) to PM070WL3 interface Assignment:

Input terminal of THC63LVDM63A		Graphic controller output signal		Output signal symbol	To PM070WL3 interface terminal (Symbol)
Symbol	No.	Symbol	Function		
TIN0	44	R0	Red pixel data (LSB)	} Tout0- Tout0+	No.5 : IN0- No.6 : IN0+
TIN1	45	R1	Red pixel data		
TIN2	47	R2	Red pixel data		
TIN3	48	R3	Red pixel data		
TIN4	1	R4	Red pixel data		
TIN5	3	R5	Red pixel data(MSB)		
TIN6	4	G0	Green pixel data (LSB)	} Tout1- Tout1+	No.8 : IN1- No.9 : IN1+
TIN7	6	G1	Green pixel data		
TIN8	7	G2	Green pixel data		
TIN9	9	G3	Green pixel data		
TIN10	10	G4	Green pixel data		
TIN11	12	G5	Green pixel data(MSB)		
TIN12	13	B0	Blue pixel data(LSB)	} Tout2- Tout2+	No.11 : IN2- No.12 : IN2+
TIN13	15	B1	Blue pixel data		
TIN14	16	B2	Blue pixel data		
TIN15	18	B3	Blue pixel data		
TIN16	19	B4	Blue pixel data		
TIN17	20	B5	Blue pixel data(MSB)		
TIN18	22	Hsync	Horizontal Synchronous Signal	} Tout2+	No.12 : IN2+
TIN19	23	Vsync	Vertical Synchronous Signal		
TIN20	25	DENB	Compound Synchronization signal		
CLK in	26	CLK	Data sampling clock	TCLK out- TCLK out+	No.14 : CLK - No.15 : CLK+

DENB input signal.

If customer wanted to off the DENB mode , you must keep the DENB always High or Low.

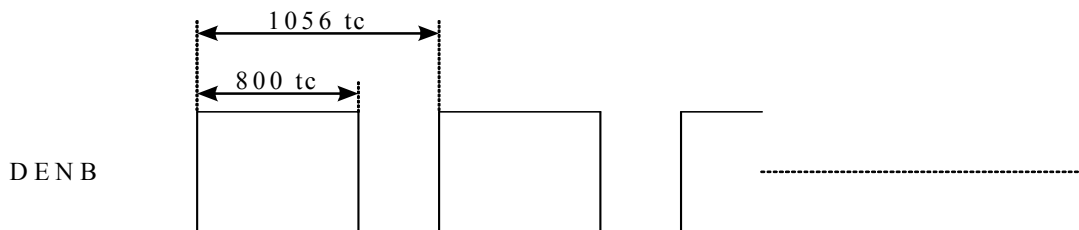

(tc: the period of sampling clock)

6. Absolute Maximum Ratings:

GND=0V, Ta=25°C

Parameters	Symbol	MIN.	MAX.	Unit	Remark
Supply Voltage	V _{CC}	-0.3	+4.0	V	
Input Signals Voltage	V _{IN}	-0.3	V _{CC} +0.3	V	Note 6-1
Backlight Driving Frequency	F _L	0	100	KHz	

Note 6-1: LVDS signal.

7. Electrical Characteristics

7-1) Recommended Operating Conditions:

GND = 0V , Ta = 25°C

Item	Symbol	Min.	Typ.	Max.	Unit	Remark
Supply Voltage	V _{CC}	3.0	3.3	3.6	V	
Current Dissipation	I _{CC}	-	199.2	217.3	mA	Note 7-1
LVDS Differential input high threshold	V _{TH}	-	-	100	mV	Note 7-2
LVDS Differential input low threshold	V _{TL}	-100	-	-		
V _{com} Voltage	V _{com}	-	3.1	-	V	

Note 7-1 : To test the current dissipation of V_{CC}, using the “color bars” testing pattern shown as below

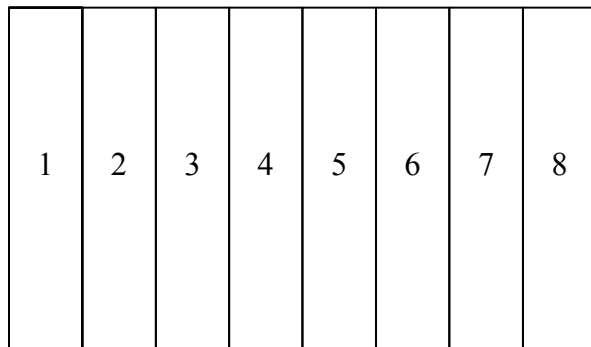

1. White
2. Yellow
3. Cyan
4. Green
5. Magenta
6. Red
7. Blue
8. Black

I_{CC} current dissipation testing pattern

Note7-2 : Please refers to THC63LVDF64A specification by THINE. This LCD module conforms to LVDS standard.

7-2) Backlight driving

Connector type: JST BHSR-02VS-1

Pin No	Symbol	Description	Remark
1	+	Input terminal (Positive electrode side)	Wire color : Red
2	-	Input terminal (Ground side)	Wire Color : Black

7-3) Recommended Driving Condition for LED Back Light

GND = 0 V , Ta = 25°C

Parameter	Symbol	Min	TYP	MAX	Unit	Remark
Supply voltage of LED backlight	V_{LED}	-	11.0	11.5	V	$I_{LED} = 20 \text{ mA}$
Supply current of LED backlight	I_{LED}	-	20	-	mA	Note 7-3
Backlight Power Consumption	P_{LED}	-	2.42	2.53	W	Note 7-4

Note 7-3 : The LED driving condition is defined for each LED module. (3 LED Serial)

Note 7-4 : $P_{LED} = V_{LED-1} * I_{LED-1} + V_{LED-2} * I_{LED-2} \dots + V_{LED-10} * I_{LED-10} + V_{LED-11} * I_{LED-11}$

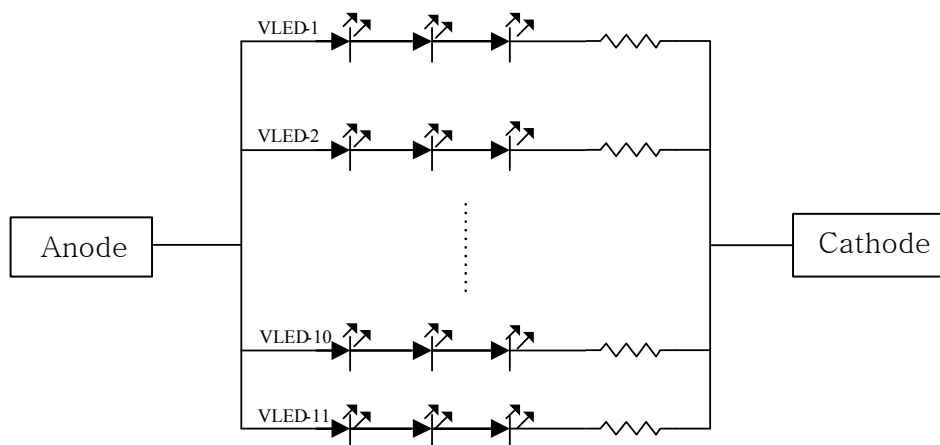

7-4) Power Consumption

Parameter	Symbol	Typ.	Max.	Unit	Remark
LCD Power consumption (W/O BL)	-	0.66	0.72	W	
LED Backlight Power Consumption	-	2.42	2.53	W	Note 7-5
Total Power Consumption	-	3.02	3.25	W	

Note 7-5: Backlight lamp power consumption is calculated by $I_L \times V_L$

8. Pixel Arrangement

The LCD module pixel arrangement is the stripe.

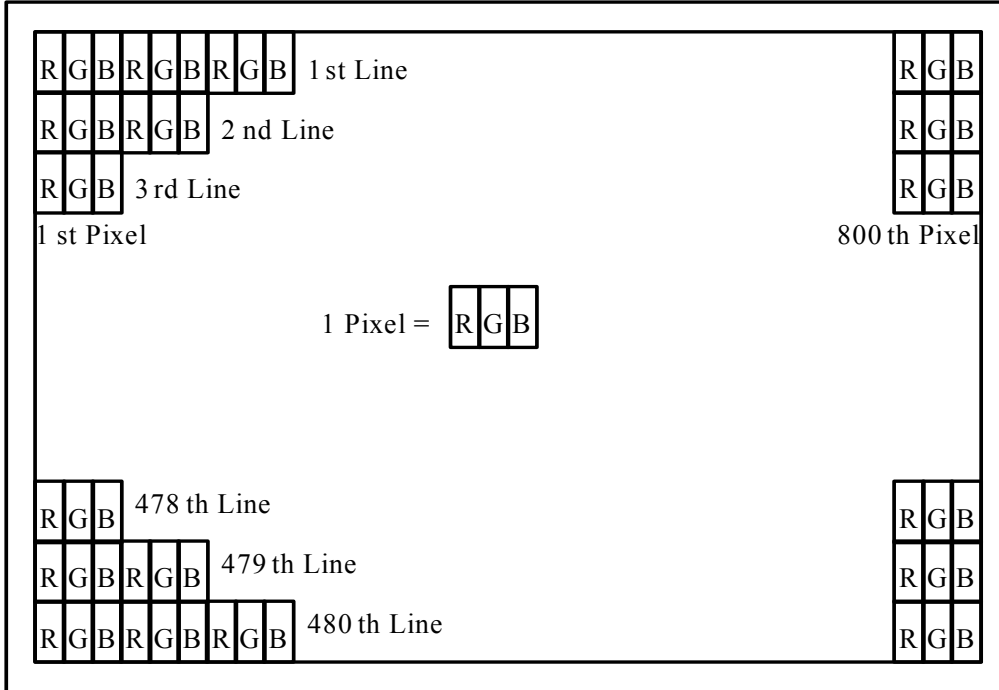

9. Display Color and Gray Scale Reference

Color		Input Color Data																	
		Red						Green						Blue					
		R5	R4	R3	R2	R1	R0	G5	G4	G3	G2	G1	G0	B5	B4	B3	B2	B1	B0
Basic Colors	Black	0	0	0	0	0	0	0	0	0	0	0	0	0	0	0	0	0	0
	Red (63)	1	1	1	1	1	1	0	0	0	0	0	0	0	0	0	0	0	0
	Green (63)	0	0	0	0	0	0	1	1	1	1	1	1	0	0	0	0	0	0
	Blue (63)	0	0	0	0	0	0	0	0	0	0	0	0	1	1	1	1	1	1
	Cyan	0	0	0	0	0	0	1	1	1	1	1	1	1	1	1	1	1	1
	Magenta	1	1	1	1	1	1	0	0	0	0	0	0	1	1	1	1	1	1
	Yellow	1	1	1	1	1	1	1	1	1	1	1	1	0	0	0	0	0	0
	White	1	1	1	1	1	1	1	1	1	1	1	1	1	1	1	1	1	1
Red	Red (00)	0	0	0	0	0	0	0	0	0	0	0	0	0	0	0	0	0	0
	Red (01)	0	0	0	0	0	1	0	0	0	0	0	0	0	0	0	0	0	0
	Red (02)	0	0	0	0	1	0	0	0	0	0	0	0	0	0	0	0	0	0
	Darker																		
	↓	↓	↓	↓	↓	↓	↓	↓	↓	↓	↓	↓	↓	↓	↓	↓	↓	↓	↓
	Brighter																		
	Red (61)	1	1	1	1	0	1	0	0	0	0	0	0	0	0	0	0	0	0
	Red (62)	1	1	1	1	1	0	0	0	0	0	0	0	0	0	0	0	0	0
Red (63)	1	1	1	1	1	1	0	0	0	0	0	0	0	0	0	0	0	0	
Green	Green (00)	0	0	0	0	0	0	0	0	0	0	0	0	0	0	0	0	0	0
	Green (01)	0	0	0	0	0	0	0	0	0	0	0	1	0	0	0	0	0	0
	Green (02)	0	0	0	0	0	0	0	0	0	0	1	0	0	0	0	0	0	0
	Darker																		
	↓	↓	↓	↓	↓	↓	↓	↓	↓	↓	↓	↓	↓	↓	↓	↓	↓	↓	↓
	Brighter																		
	Green (61)	0	0	0	0	0	0	1	1	1	1	0	1	0	0	0	0	0	0
	Green (62)	0	0	0	0	0	0	1	1	1	1	1	0	0	0	0	0	0	0
Green (63)	0	0	0	0	0	0	1	1	1	1	1	1	0	0	0	0	0	0	
Blue	Blue (00)	0	0	0	0	0	0	0	0	0	0	0	0	0	0	0	0	0	0
	Blue (01)	0	0	0	0	0	0	0	0	0	0	0	0	0	0	0	0	0	1
	Blue (02)	0	0	0	0	0	0	0	0	0	0	0	0	0	0	0	0	1	0
	Darker																		
	↓	↓	↓	↓	↓	↓	↓	↓	↓	↓	↓	↓	↓	↓	↓	↓	↓	↓	↓
	Brighter																		
	Blue (61)	0	0	0	0	0	0	0	0	0	0	0	0	1	1	1	1	0	1
	Blue (62)	0	0	0	0	0	0	0	0	0	0	0	0	1	1	1	1	1	0
Blue (63)	0	0	0	0	0	0	0	0	0	0	0	0	1	1	1	1	1	1	

10. Block Diagram

10-2) TFT-module Block Diagram

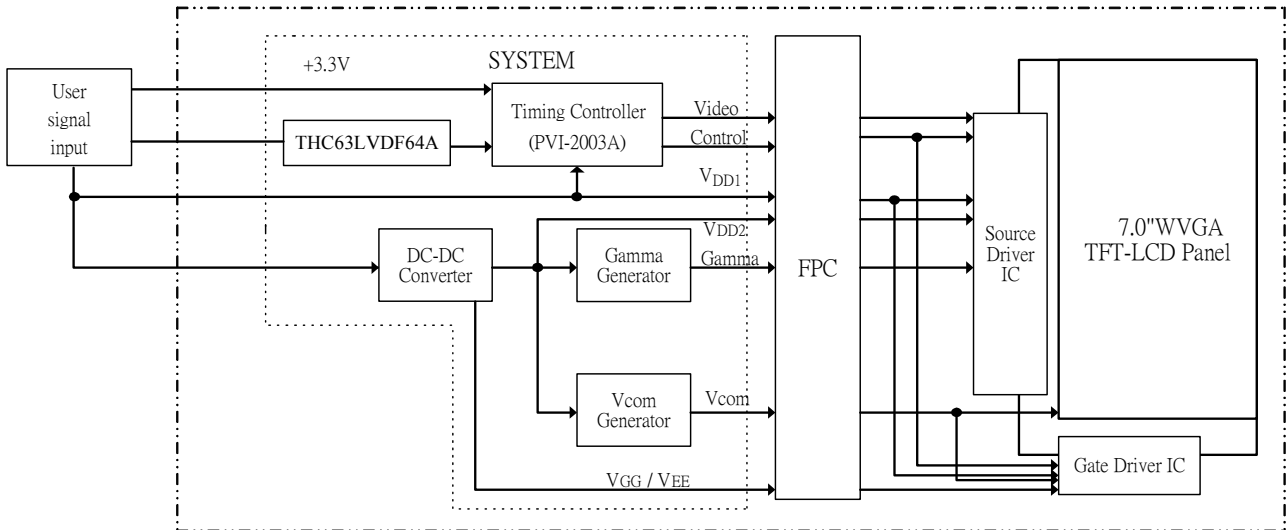

11. Interface Timing

11.1) Timing Parameters

		Symbol	Min.	Typ.	Max.	Unit	Remark	
Power supply		VCC	3.0	3.3	3.6	V		
CLK	Frequency	1/tc	-	32	-	MHz		
		tc	-	31.25	-	ns		
HSYNC	Period	Hp	-	33	-	us		
			-	1056	-	tc		
	Display period	Hdp	-	800	-	tc		
	Pulse width	Hpw	-	128	-	tc		
	Back-porch	Hbp	-	86	-	tc		
	Front-porch	Hfp	-	42	-	tc		
	Hpw+Hbp			-	214	-	tc	
	Hsync-CLK	Hhc	10	-	Tc-10	ns		
	Vsync-Hsync	Hvh	0	0	200	tc		
VSYNC	Period	Vp	-	17.325	-	ms		
			-	525	-	Hp		
	Display period	Vdp	-	480	-	Hp		
	Pulse width	Vpw	-	2	-	Hp		
	Back-porch	Vbp	-	33	-	Hp		
	Front-porch	Vfp	-	10	-	Hp		
	Vpw+Vbp			-	35	-	Hp	
DENB	Horizontal scanning period	T1	860	1056	1064	tc		
	Horizontal display period	T2	-	800	-	tc		
	Vertical display period	T3	-	480	-	T1		
	Frame cycling period	T4	520	525	800	T1		
R,G,B	CLK-DATA	Dcd	10	-	-	ns		
	DATA-CLK	Ddc	8	-	-	ns		

11.2) The Timing Diagram

a. Input signal range

a.1

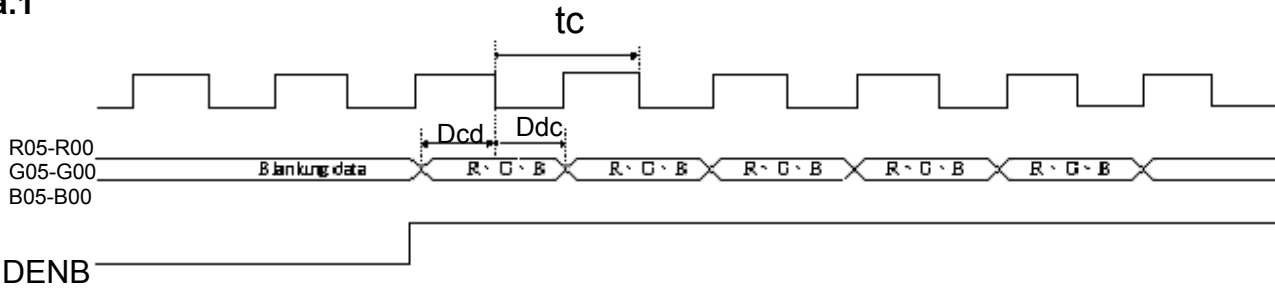

a.2 HSYNC timing

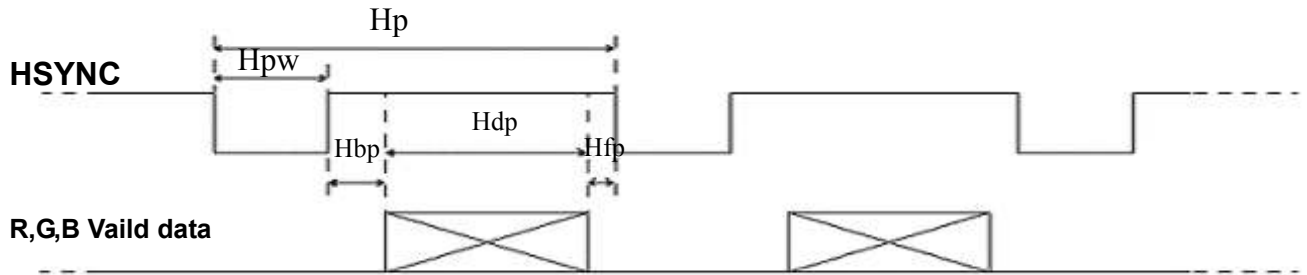

a.3 CLK, HSYNC relationship



a.4 HSYNC, VSYNC relationship

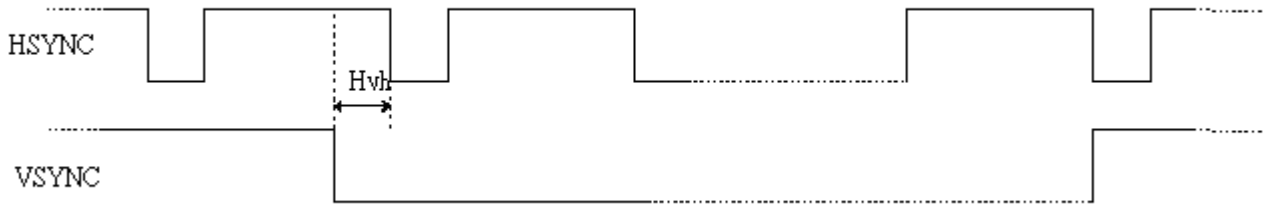

a.5 VSYNC timing

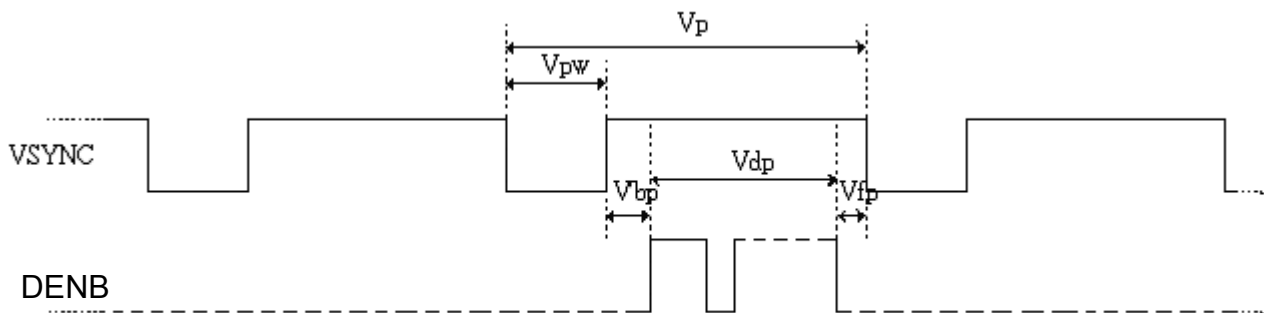

a.6 DENB timing

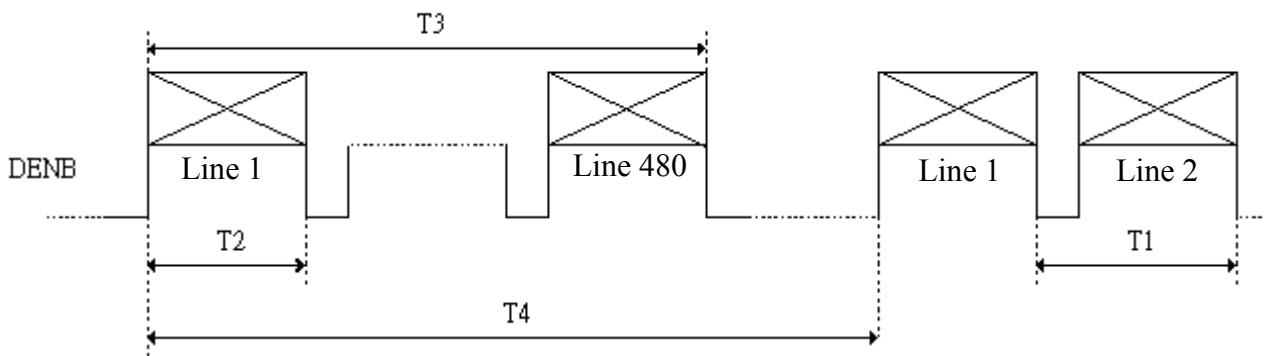

12. Power On Sequence

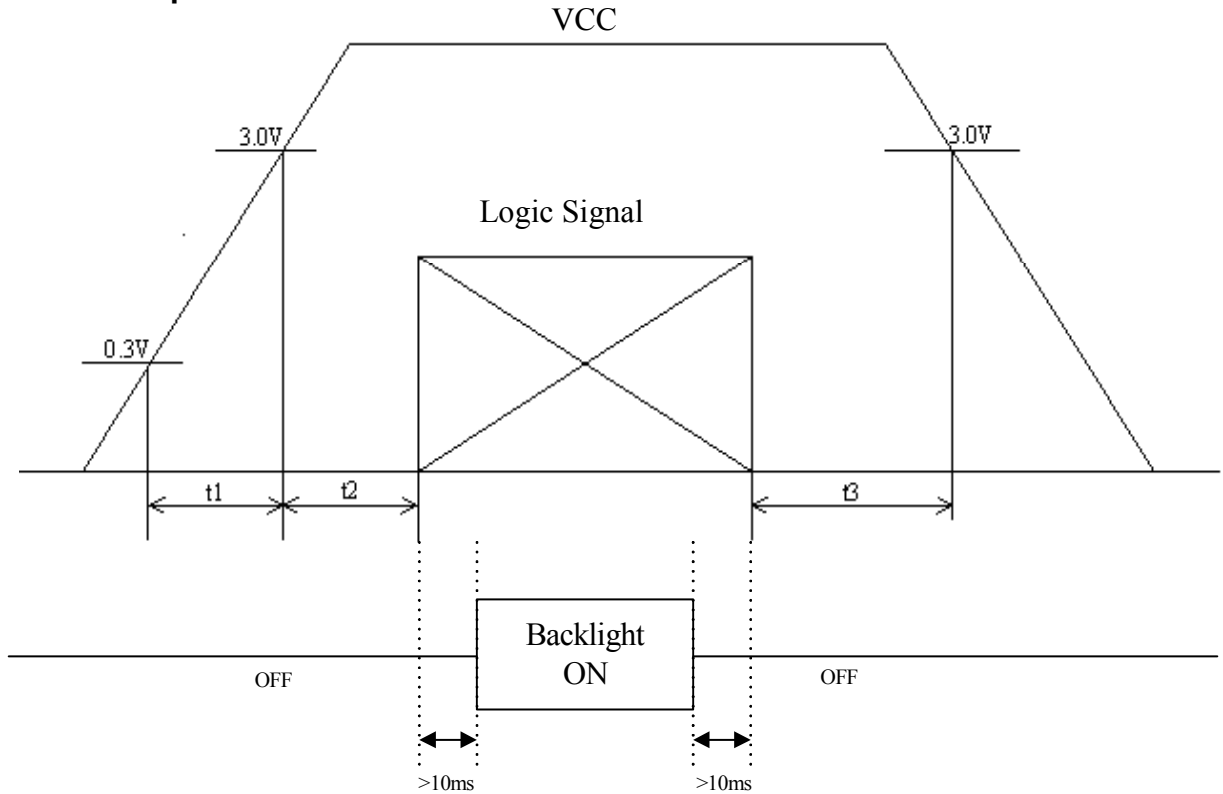

1. $0 < t_1 \leq 20\text{ms}$
2. $0 < t_2 \leq 50\text{ms}$
3. $0 < t_3 \leq 1\text{s}$

13. Optical Characteristics

13-1) Specification:

 $T_a = 25^\circ\text{C}$

Parameter	Symbol	Condition	MIN.	TYP.	MAX.	Unit	Remarks
Viewing Angle	Horizontal	$\theta 21.22$	± 55	± 60	-	deg	Note 13-1
	Vertical	$\theta 12$ (to 12 'clock)	35	40	-	deg	
		$\theta 11$ (to 6 o'clock)	50	55	-	deg	
Contrast Ratio	CR	$\theta = 0^\circ$	250	400	-	-	Note 13-2
Response time	Rise	T_r	-	15	30	ms	Note 13-3
	Fall	T_f	-	25	50	ms	
Brightness	L	$\theta = 0^\circ / \varphi = 0$	350	400	-	cd/m^2	
Luminance Uniformity	U	-	70	75	-	%	Note 13-4
White Chromaticity	x	$\theta = 0^\circ / \varphi = 0$	0.28	0.31	0.34	-	
	y		0.30	0.33	0.36	-	
Cross Talk	-	$\theta = 0^\circ$	-	-	3.5	%	Note 13-5
LED Life Time	-	-	20000	30000	-	hr	Note 13-6

All the optical measurement shall be executed 10 minutes after backlight being turn-on. The optical characteristics shall be measured in dark room (ambient illumination on panel surface less than 1 Lux). The measuring configuration shows as following figure.

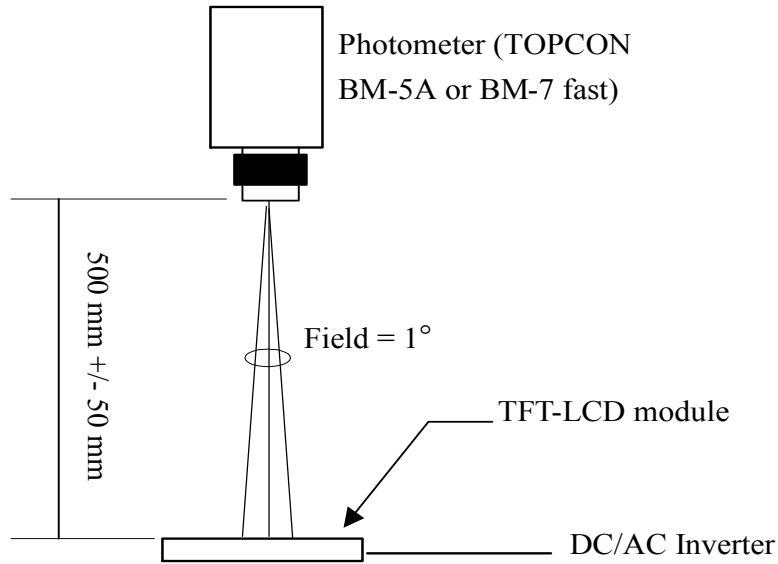

Optical characteristics measuring configuration

Topcon BM-5A or BM-7 fast luminance meter 1° field of view is used in the testing (after 10 minutes' operation). The typical luminance value is measured at LED current 20 mA.

Note 13-1: The definitions of viewing angles are as follow.

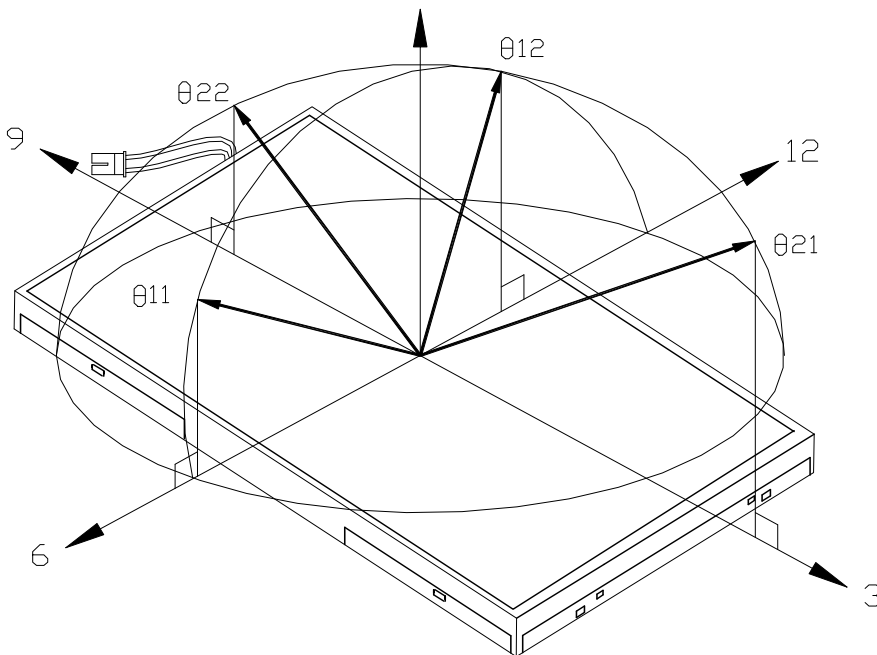

Note 13-2: The definition of contrast ratio $CR = \frac{\text{Luminance at gray level 63}}{\text{Luminance at gray level 0}}$

Note 13-3: Definition of Response Time T_r and T_f :

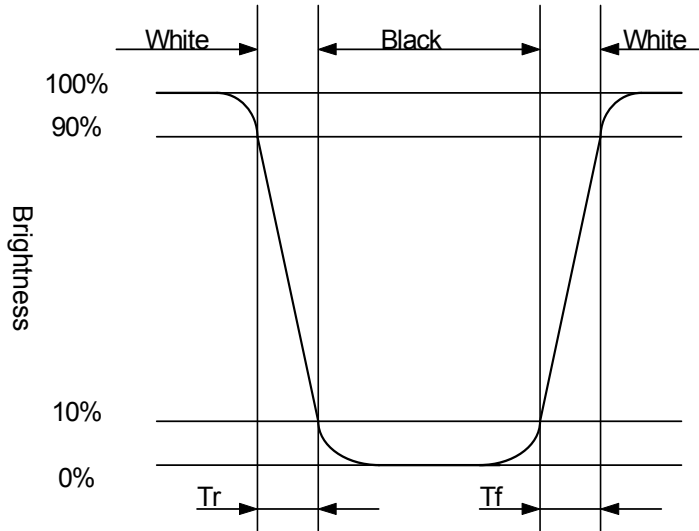

Note 13-4: The uniformity of LCD is defined as

$$U = \frac{\text{The Minimum Brightness of the 9 testing Points}}{\text{The Maximum Brightness of the 9 testing Points}}$$

- Luminance meter : BM-5A or BM-7 fast(TOPCON)
- Measurement distance : 500 mm +/- 50 mm
- Ambient illumination : < 1 Lux
- Measuring direction : Perpendicular to the surface of module
- The test pattern is white (Gray Level 63).

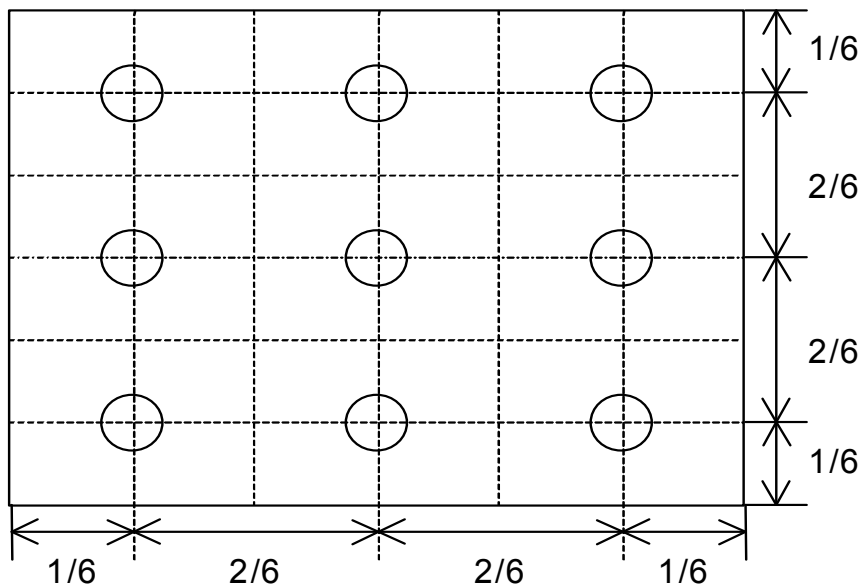

Note 13-5: Cross Talk (CTK) = $\frac{|YA-YB|}{YA} \times 100\%$

YA: Brightness of Pattern A
 YB: Brightness of Pattern B
 Luminance meter : BM 5A or BM-7 fast (TOPCON)
 Measurement distance : 500 mm +/- 50 mm
 Ambient illumination : < 1 Lux
 Measuring direction : Perpendicular to the surface of module

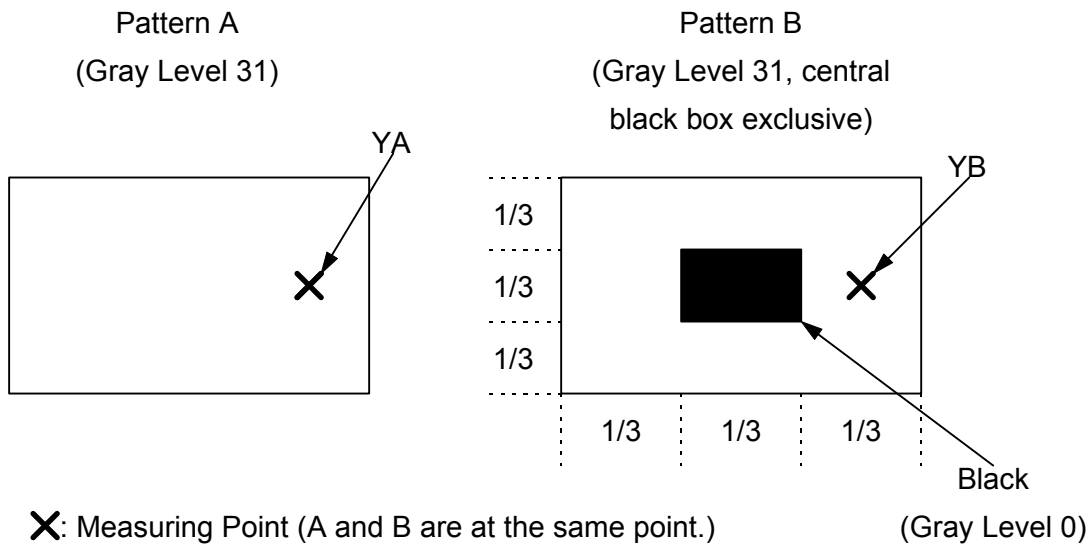

Note 13-6: The “LED Life time “ is defined as the module brightness decrease to 50% original Brightness that the ambient temperature is 25°C and I_{LED} =20mA.

14. Handling Cautions

14-1) Mounting of module

- a) Please power off the module when you connect the input/output connector.
- b) Please connect the ground pattern of the inverter circuit surely. If the connection is not perfect, some following problems may happen possibly.
 - 1. The noise from the backlight unit will increase.
 - 2. The output from inverter circuit will be unstable.
 - 3. In some cases a part of module will heat.
- c) Polarizer which is made of soft material and susceptible to flaw must be handled carefully.
- d) Protective film (Laminator) is applied on surface to protect it against scratches and dirt
- e) Please following the tear off direction as figure14-1 to remove the protective film as slowly as possible, so that electrostatic charge can be minimized.

14-2) Precautions in mounting

- a) When metal part of the TFT-LCD module (shielding lid and rear case) is soiled, wipe it with soft dry cloth.
- b) Wipe off water drops or finger grease immediately. Long contact with water may cause discoloration or spots.
- c) TFT-LCD module uses glass which breaks or cracks easily if dropped or bumped on hard surface. Please handle with care.
- d) Since CMOS LSI is used in the module. So take care of static electricity and earth yourself when handling.

14-3) Adjusting module

- a) Adjusting volumes on the rear face of the module have been set optimally before shipment.
- b) Therefore, do not change any adjusted values. If adjusted values are changed, the specifications described may not be satisfied.

14-4) Others

- a) Do not expose the module to direct sunlight or intensive ultraviolet rays for many hours.
- b) Store the module at a room temperature place.
- c) The voltage of beginning electric discharge may over the normal voltage because of leakage current from approach conductor by to draw lump read lead line around.
- d) If LCD panel breaks, it is possibly that the liquid crystal escapes from the panel. Avoid putting it into eyes or mouth. When liquid crystal sticks on hands, clothes or feet. Wash it out immediately with soap.
- e) Observe all other precautionary requirements in handling general electronic components.
- f) Please adjust the voltage of common electrode as material of attachment by 1 module.

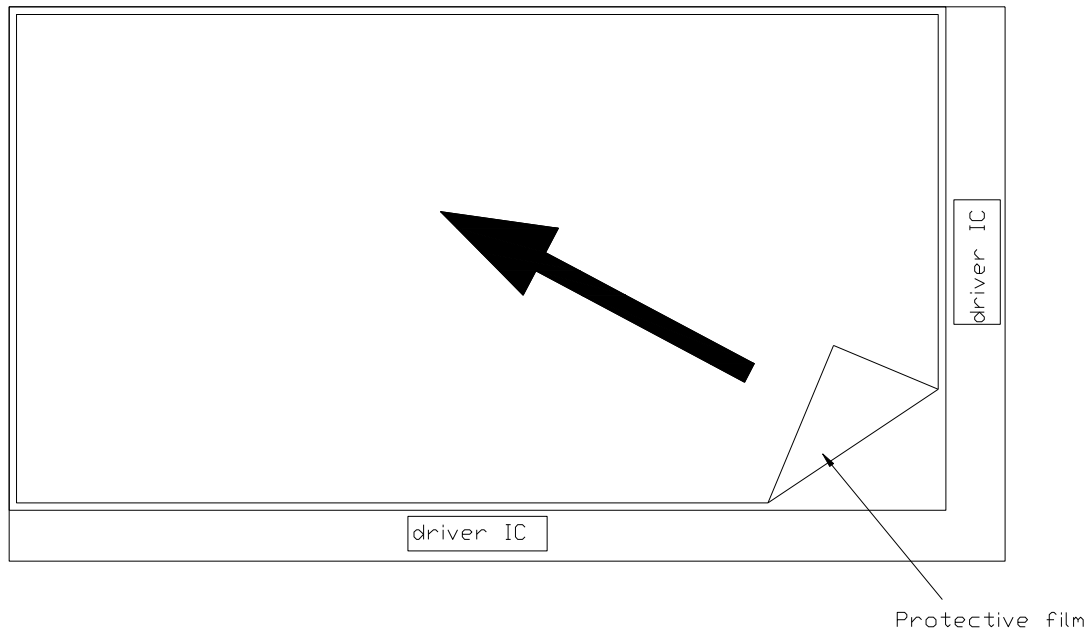

Figure 14-1 the way to peel off protective film

15. Reliability Test

No	Test Item	Test Condition	Remark
1	High Temperature Storage Test	Ta = +85°C, 240 hrs	
2	Low Temperature Storage Test	Ta = -40°C, 240 hrs	
3	High Temperature Operation Test	Ta = +80°C, 240 hrs	
4	Low Temperature Operation Test	Ta = -30°C, 240 hrs	
5	High Temperature & High Humidity Operation Test	Ta = +60°C, 90%RH, 240 hrs (No Condensation)	
6	Thermal Cycling Test (non-operating)	-30°C → +80°C, 200 Cycles 30min 30min	
7	Vibration Test (non-operating)	Frequency : 10 ~ 55 Hz, Amplitude : 1 mm Sweep time: 11 min Test Period: 6 Cycles for each direction of X, Y, Z	
8	Shock Test (non-operating)	100G, 6ms Direction: ±X, ±Y, ±Z Cycle: 3 times	
9	Electrostatic Discharge Test (non-operating)	Contact mode: ±8KV, 10times/point , 9 points/panel face Air mode: 150pF, 330Ω Air : ±15KV	

Ta: ambient temperature

[Criteria]

In the standard conditions, there is not display function NG issue occurred. (including : line defect ,no image). All the cosmetic specification is judged before the reliability stress.

16. Packing Diagram

ZONE	REV.	DOCUMENT NO.	DESCRIPTION	DATE	REV. BY																									
<p>NOTE: 1. Q'TY: 40 pcs panel/carton. 2. Dimension: 530*295*230mm 3. Weight: 13.1 Kg</p>																														
		<table border="1" style="width:100%; border-collapse: collapse;"> <thead> <tr> <th>ITEM</th> <th>PART NO.</th> <th>DESCRIPTION</th> <th>QTY</th> <th>REMARK</th> </tr> </thead> <tbody> <tr> <td>4</td> <td>50-0100111</td> <td>CARTON</td> <td>1</td> <td></td> </tr> <tr> <td>3</td> <td>50-0500181</td> <td>PINK Bag 115*230mm</td> <td>40</td> <td>抗靜電</td> </tr> <tr> <td>2</td> <td></td> <td>PM070WL3</td> <td>40</td> <td></td> </tr> <tr> <td>1</td> <td>50-0301681</td> <td>瓦楞隔板反緩衝材料</td> <td>1</td> <td>上蓋+底座</td> </tr> </tbody> </table>		ITEM	PART NO.	DESCRIPTION	QTY	REMARK	4	50-0100111	CARTON	1		3	50-0500181	PINK Bag 115*230mm	40	抗靜電	2		PM070WL3	40		1	50-0301681	瓦楞隔板反緩衝材料	1	上蓋+底座		
ITEM	PART NO.	DESCRIPTION	QTY	REMARK																										
4	50-0100111	CARTON	1																											
3	50-0500181	PINK Bag 115*230mm	40	抗靜電																										
2		PM070WL3	40																											
1	50-0301681	瓦楞隔板反緩衝材料	1	上蓋+底座																										
MTL.SPEC.		UNSPECIFIED TOL'S		REMARK																										
		ANGLE																												
		ROUGHNESS																												
APPROVE	Frank Shin	06.12.14	SCALE	UNIT	SHEET																									
CHECK	Frank Shin	06.12.14			1 of 1																									
DRAWN	Stevenc	06.12.14	MTL.NO.		DWG FILE:																									
					REV. 01																									
					A4 SIZE																									

元太科技工業股份有限公司
Prime View International Co., Ltd.

DWG.TITLE
7" WVGA(LED B/L)+PCB(LVDS) Packing