

Version : 4.0

TECHNICAL SPECIFICATION

MODEL NO : PD064VT8

The content of this information is subject to be changed without notice.
Please contact E Ink or its agent for further information.

Customer's Confirmation

Customer _____

Date _____

By _____

E Ink's Confirmation

Confirmed By _____

申峰坤

Prepared By _____

李穎節

Revision History

Rev.	Eng.	Issued Date	Revised Contents
0.1	Sarah Huang	Oct 29, 2007	Preliminary
1.0	Sarah Huang	Jan 08, 2008	Add Page 22 13.Packing
2.0	Sarah Huang	June 10, 2008	Modify Page5 4. Mechanical Drawing of TFT-LCD Module: Add UL Label
3.0	Lio Lee	Mar. 03 ,2009	Page 7 6. Absolute Maximum Ratings Add HTOT & LTOT & HTST & LTST condition Page20 11. Reliability Test Modify HTOT from +70°C to +80°C LTOT from -20°C to -30°C Vibration test from Gravity :9.8m/s to Gravity :19.6m/s(2G)
4.0		Aug 24, 2011	Update to E Ink logo

TECHNICAL SPECIFICATION

CONTENTS

<i>NO.</i>	<i>ITEM</i>	<i>PAGE</i>
-	Cover	1
-	Revision History	2
-	Contents	3
1	Application	4
2	Features	4
3	Mechanical Specifications	4
4	Mechanical Drawing of TFT-LCD module	5
5	Input / Output Terminals	6
6	Absolute Maximum Ratings	7
7	Electrical Characteristics	8
8	Power On Sequence	15
9	Optical Characteristics	16
10	Handling Cautions	19
11	Reliability Test	20
12	Block Diagram	21
13	Packing	22

1. Application

This product applies computer peripheral, industrial meter, image communication and multi-media.

2. Features

- . Compatible with VGA-480, VGA-400, VGA-350 mode
- . Support the DENB mode
- . Pixel in stripe configuration
- . Slim and compact
- . Display Colors: 262,144 colors
- . Image Reversion: Up/Down and Left/Right
- . TTL transmission interface

3. Mechanical Specifications

Parameter	Specifications	Unit
Screen Size	6.4 (diagonal)	inch
Display Format	640×(R,G,B)×480	dot
Active Area	129.6 (H)×97.44 (V)	mm
Outline Dimension	175.4 (W)×126.9 (H)×12.5 (D) (Typ.)	mm
Pixel Pitch	0.2025 (H)×0.203 (V)	mm
Pixel Configuration	Stripe	
Surface Treatment	Anti – Glare &Wide View film	
Display mode	Normally white	
Back-light	Middle power 24*2-LED	
Weight	321±15	g
Gray scale inversion direction	6 o'clock [Note 9-1]	

4. Mechanical Drawing of TFT-LCD Module

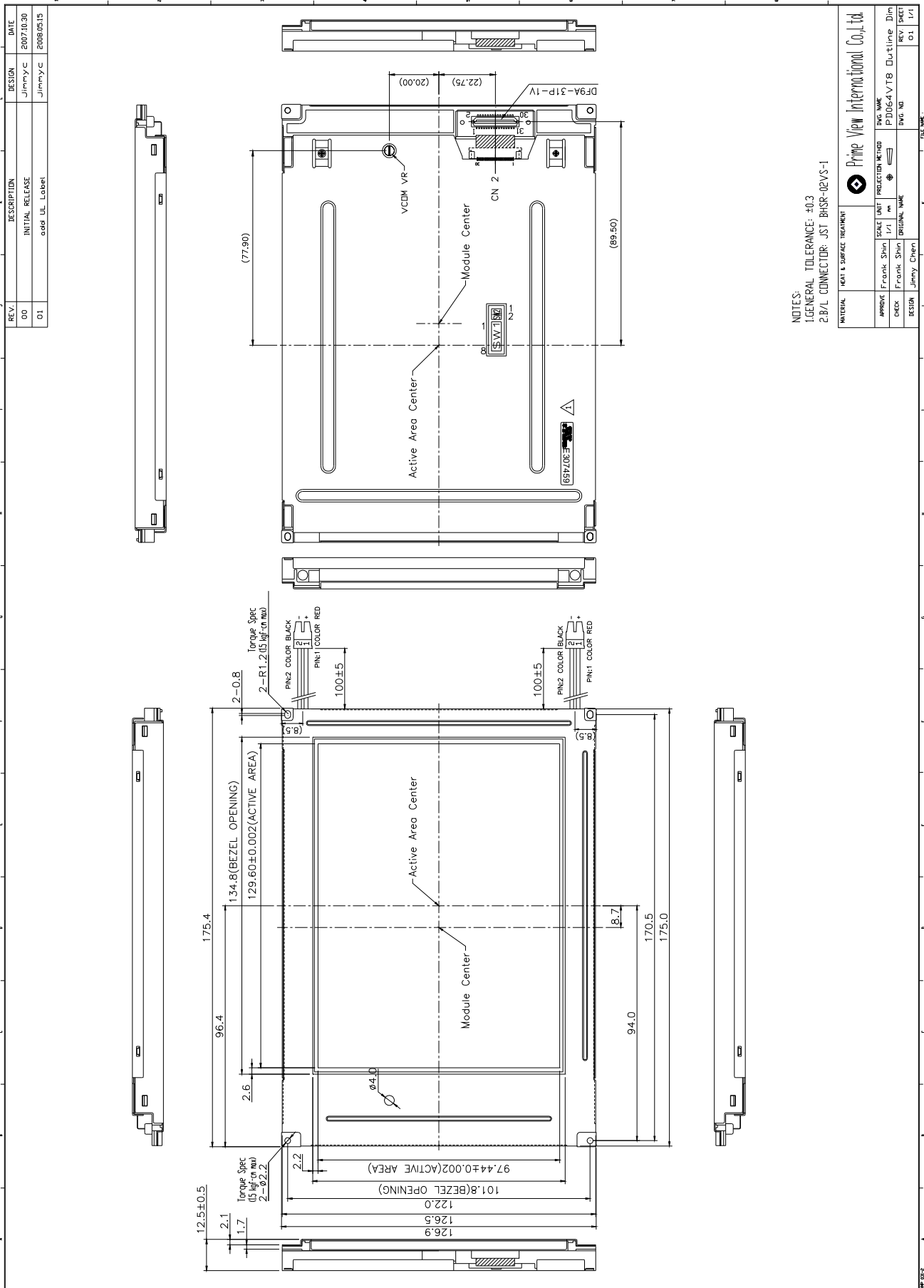

REV.	DESCRIPTION	DESIGN	DATE
00	INITIAL RELEASE	Jimmyc	2007.10.30
01	add UL Label	Jimmyc	2008.05.15

NOTES:
1.GENERAL TOLERANCE: ±0.3
2.B/L CONNECTOR: JST BHSR-02VS-1

MATERIAL		PRIME VIEW INTERNATIONAL CO., LTD.	
APPROVE	FRANK SHIN	SCALE	1:1
CHECK	FRANK SHIN	PROJECTION METHOD	1ST ANGLE
DESIGN	JIMMY CHEN	ORIGINAL FILE	176101
		DATE	2008.05.15
		PROJECT NO.	PD064VT8
		DATE	2008.05.15
		REV.	01
		REV. DATE	2008.05.15

5. Input / Output Terminals

5-1) TFT-LCD Panel Driving

LCD module connector (Reference)-DF9A-31P-1V

Pin No.	Symbol	Function	Remark
1	GND	Ground (0V)	
2	CLK	Clock Signal for Sampling Image Digital Data	
3	Hsync	Horizontal Synchronous Signal	Note 5-1
4	Vsync	Vertical Synchronous Signal	
5	GND	Ground (0V)	
6	R0	Red Image Data Signal (LSB)	
7	R1	Red Image Data Signal	
8	R2	Red Image Data Signal	
9	R3	Red Image Data Signal	
10	R4	Red Image Data Signal	
11	R5	Red Image Data Signal (MSB)	
12	GND	Ground (0V)	
13	G0	Green Image Data Signal (LSB)	
14	G1	Green Image Data Signal	
15	G2	Green Image Data Signal	
16	G3	Green Image Data Signal	
17	G4	Green Image Data Signal	
18	G5	Green Image Data Signal (MSB)	
19	GND	Ground (0V)	
20	B0	Blue Image Data Signal (LSB)	
21	B1	Blue Image Data Signal	
22	B2	Blue Image Data Signal	
23	B3	Blue Image Data Signal	
24	B4	Blue Image Data Signal	
25	B5	Blue Image Data Signal (MSB)	
26	GND	Ground (0V)	
27	DENB	Enable	Note 5-1 Note 5-2
28	VCC	DC +5.0V Power Supply	Note 5-3
29	VCC	DC +5.0V Power Supply	
30	R/L	Horizontal Image Shift-direction Select Signal	Note 5-4
31	U/D	Vertical Image Shift-direction Select Signal	

Note 5-1 : The relationship between DENB & SYNC. mode

1. DENB mode with the top priority.
2. When working with the SYNC. mode , the TFT-LCD module is compatible with three kinds of VGA timing . They are VGA-480 , VGA-400 and VGA-350 mode . The polarization of Hsync and Vsync determine the timings.

Mode	DENB	VGA-480	VGA-400	VGA-350
SYNC. Hsync Polarization	Don't care	Negative / Positive	Negative	Positive
Vsync Polarization	Don't care	Negative / Positive	Positive	Negative

Note 5-2 : DENB input signal.

If customer wanted to off the DENB mode , you must keep the DENB (pin 27) always High or Low.

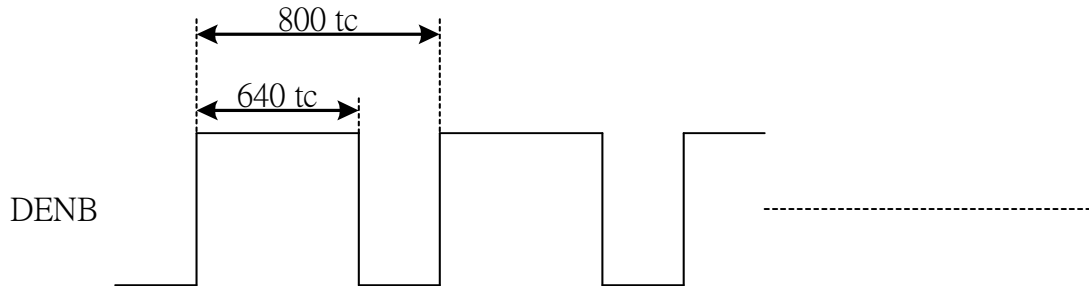

(tc: the period of sampling clock)

Note 5-3: $V_{CC}(TYP.)=+5V$

Note 5-4: The definitions of U/D & R/L

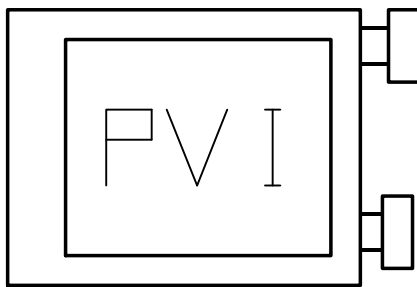

R/L(PIN 30)= High , U/D(PIN 31)= Low

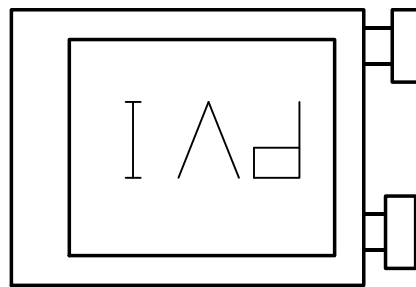

R/L(PIN 30)= Low , U/D(PIN 31)= High

5-2) Backlight driving connector: JST BHSR-02VS-1 , 2 Pins

Pin No	Symbol	Description	Remark
1	+	Input terminal (Anode)	Red
2	-	Input terminal (Cathode)	Black

6. Absolute Maximum Ratings :

The followings are maximum values , which if exceeded, may cause faulty operation or damage to the unit.

GND=0V, Ta=25°C

Parameters	Symbol	MIN.	MAX.	Unit	Remark
Supply Voltage	V_{CC}	-0.3	+7.0	V	
Input Signals Voltage	V_{-sign}	-0.3	$V_{CC}+0.3$	V	Note 6-1
Storage Temperature	Tst	-30	+80	°C	
Operation Temperature	Top	-30	+80	°C	

Note 6-1 : Input signals include CLK , Hsync , Vsync , DENB , R[0:5] , G[0:5] and B[0:5].

PD064VT8

7. Electrical Characteristics

7-1) Recommended Operating Condition for TFT-LCD panel :

GND = 0V , Ta = 25°C

Parameters	Symbol	Min.	Typ.	Max.	Unit	Remark
Supply Voltage	V _{CC}	4.75	5.0	5.25	V	
Current Dissipation	I _{CC}	-	100	120	mA	V _{CC} =+5V
Power Consumption	P _{cc}	-	0.5	0.63	W	
Supply Input Ripple Voltage	V _{CCRP}	-	-	0.1	V _{p-p}	V _{CC} =+5V
Input Signals Voltage (High)	V _{IH}	+2.6	-	-	V	
Input Signals Voltage (Low)	V _{IL}	-	-	+0.5	V	

7-2) Recommended Operating Condition for backlight:

Ta = 25°C

Parameter	Symbol	Min	TYP	MAX	Unit	Remark
Supply voltage of LED backlight	V _{LED}	-	-	(11)	V	Note 7-1
Supply current of LED backlight	I _{LED}	-	17.5	-	mA	Note 7-2
Backlight Power Consumption	P _{LED}	-	-	3.08	W	Note 7-1/7-3

Note 7-1 : I_{LED}= 17.5mA,constant current

Note 7-2 : The LED driving condition is defined for each LED module. (3 LED Serial)

Input current = 17.5mA * 8 = 140mA

Note 7-3 : P_{LED} = (V_{LED-1} * I_{LED-1} + V_{LED-2} * I_{LED-2} + V_{LED-7} * I_{LED-7} + V_{LED-8} * I_{LED-8})*2 (light bar)

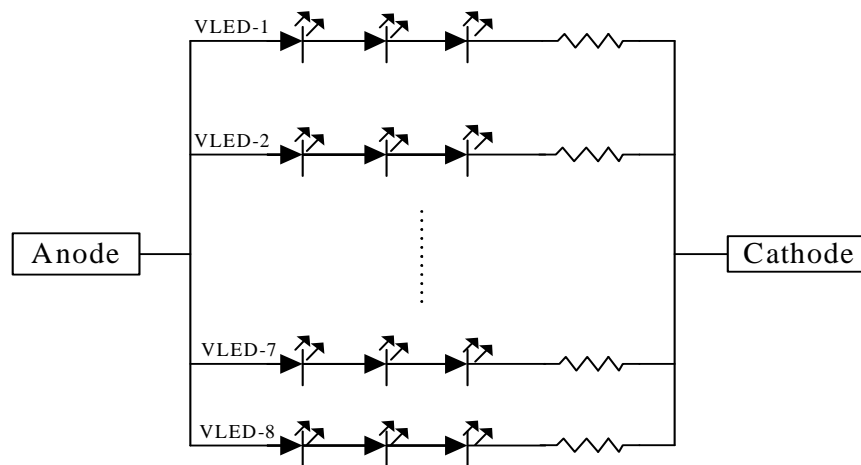

7-3) Input / Output signal timing chart

Parameters		Symbol	Format	Min.	Typ.	Max.	Unit	Note
CLK	Frequency	Fc=1/tc	All	-	25.175	-	MHz	Note 7-4
		tc	All	-	40	-	ns	
Hsync	Period	Hp	All	-	31.778	-	us	
				-	800	-	tc	
	Display period	Hd	All	-	640	-	tc	
	Pulse width	Hpw	All	12	96	139	tc	
	Back-porch	Hbp	All	12	46	139	tc	
	Front-porch	Hfp	All	-	18	-	tc	
	Hpw+Hbp			All	136	142	151	tc
Hsync-CLK		Hhc	All	10	-	Tc-10	ns	
Vsync-Hsync		Hvh	All	0	0	200	tc	
Vsync	Period	Vp	480	-	16.8	-	ms	
				515	525	800	Hp	
			400	-	14.3	-	ms	
				446	449	480	Hp	
	350	-	14.3	-	ms			
		447	449	510	Hp			
	Display period	Vdp	480	-	480	-	Hp	
			400	-	400	-		
			350	-	350	-		
	Pulse width	Vpw	All	2	2	35	Hp	
	Back-porch	Vbp	480	2	33	35	Hp	
			400	2	35	38		
			350	2	60	63		
	Front-porch	Vfp	480	1	10	-	Hp	
400			1	12	-			
350			1	37	-			
Vpw+Vbp		480	31	35	38	Hp		
		400	33	37	40			
		350	58	62	65			
Data	CLK-DATA	Dcd	All	10	-	-	ns	
	DATA-CLK	Ddc	All	10	-	-	ns	
DENB	Horizontal scanning period	T1	All	780	800	900	tc	
	Horizontal display period	T2	All	-	640	-	tc	
	Vertical display period	T3	All	-	480	-	T1	
	Frame cycling period	T4	All	515	525	800	T1	

Note 7-4 : tc is the period of sampling clock. In case of low-frequency , the image-flicker may occur.

7-4) Display Time Range

(1) Vertical Timing :

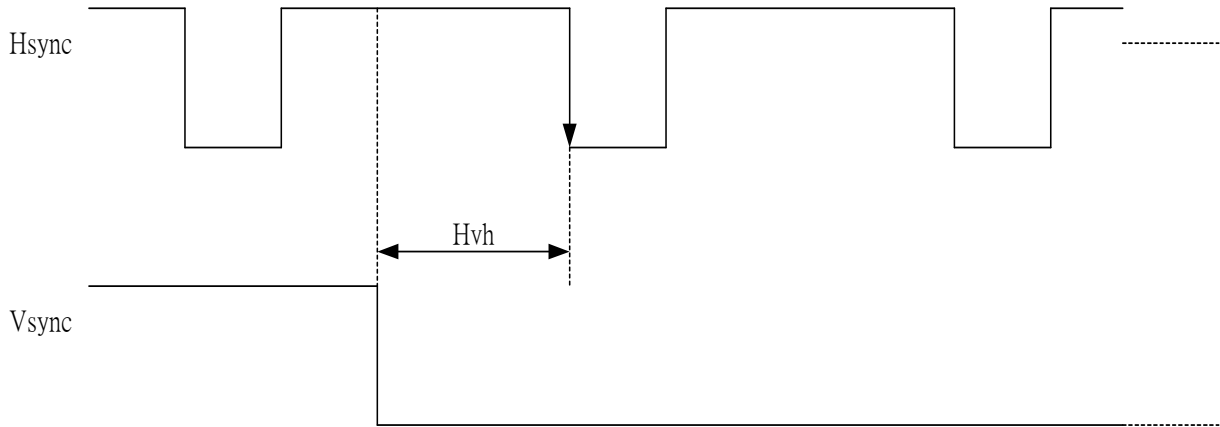

(2) Horizontal Timing :

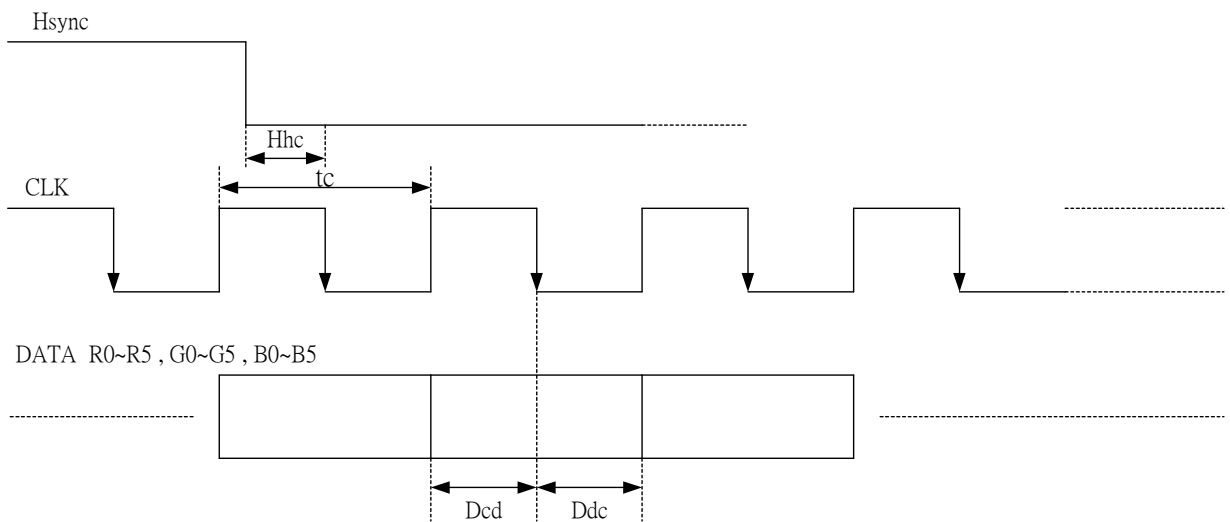

(3) DENB Timing :

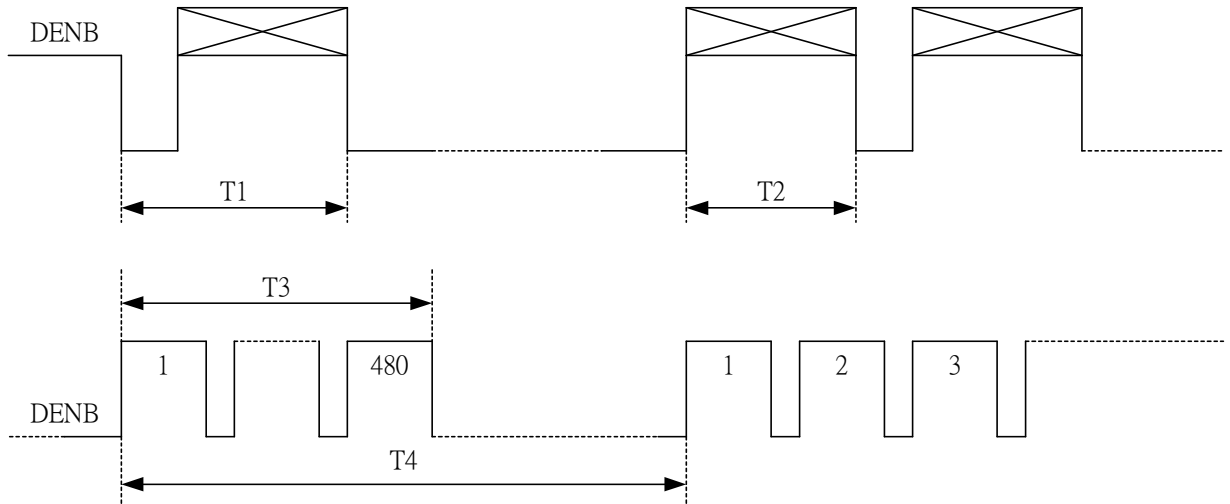

(4) Detail of Horizontal Timing :

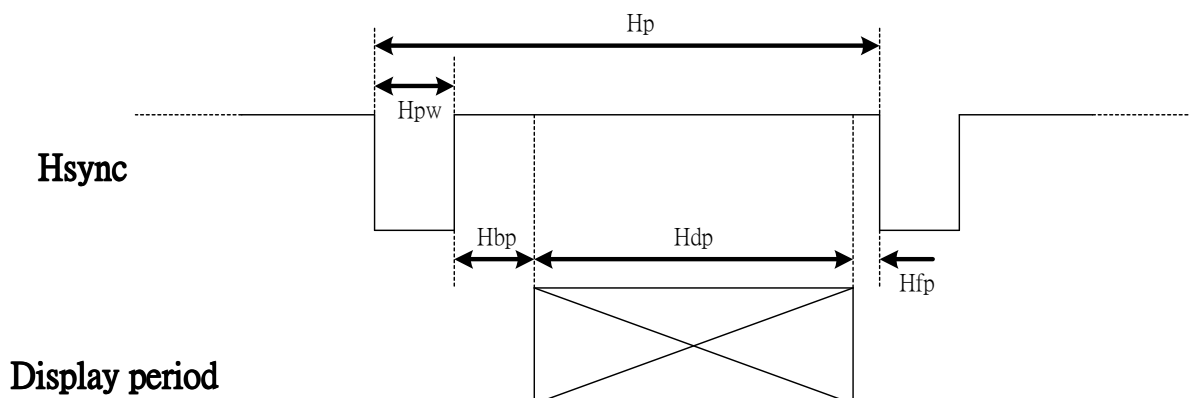

(a) VGA-480 Mode (Hsync = Positive / Negative Polarization)

Item	Description	Clock Cycles	Time
A	Horizontal Width	96	3.813 μs
B	Horizontal B-Porch	48	1.907 μs
C	Horizontal Display	640	25.422 μs
D	Horizontal F-Porch	16	0.636 μs
E	Horizontal Total	800	31.778 μs

(b) VGA-400 Mode (Hsync = Negative Polarization)

Item	Description	Clock Cycles	Time
A	Horizontal Width	96	3.813 μs
B	Horizontal B-Porch	48	1.907 μs
C	Horizontal Display	640	25.422 μs
D	Horizontal F-Porch	16	0.636 μs
E	Horizontal Total	800	31.778 μs

(c) VGA-350 Mode (Hsync = Positive Polarization)

Item	Description	Clock Cycles	Time
A	Horizontal Width	96	3.813 μs
B	Horizontal B-Porch	48	1.907 μs
C	Horizontal Display	640	25.422 μs
D	Horizontal F-Porch	16	0.636 μs
E	Horizontal Total	800	31.778 μs

(5) Detail of Vertical Timing :

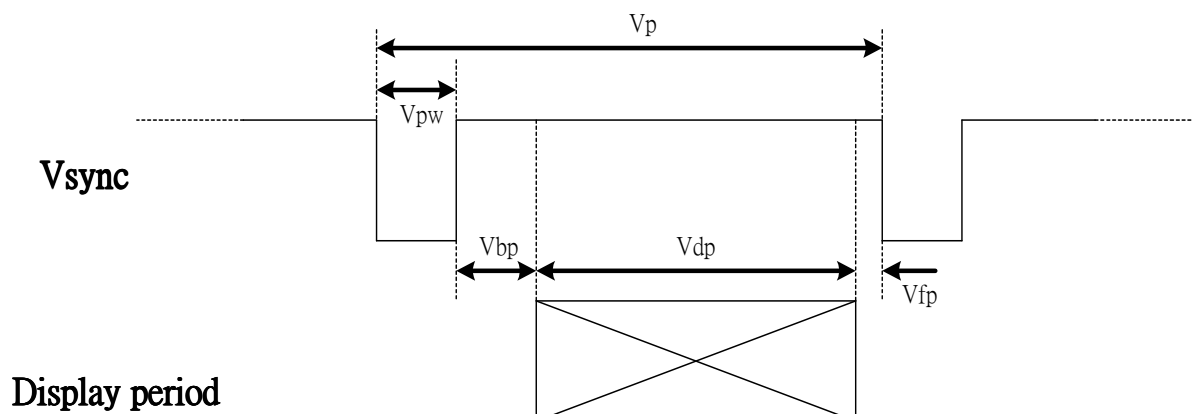

(a) VGA-480 Mode (V_{sync} = Positive / Negative Polarization)

Item	Description	Horizontal Lines	Time
A	Vertical Width	2	63.5 μs
B	Vertical B-Porch	33	1.049 ms
C	Vertical Display	480	15.253 ms
D	Vertical F-Porch	10	317.8 μs
E	Vertical Total	525	16.683 ms

(b) VGA-400 Mode (V_{sync} = Positive Polarization)

Item	Description	Horizontal Lines	Time
A	Vertical Width	2	63.5 μs
B	Vertical B-Porch	35	1.112 ms
C	Vertical Display	400	12.711 ms
D	Vertical F-Porch	12	381.0 μs
E	Vertical Total	449	14.268 ms

(c) VGA-350 Mode (V_{sync} = Negative Polarization)

Item	Description	Horizontal Lines	Time
A	Vertical Width	2	63.5 μs
B	Vertical B-Porch	60	1.907 ms
C	Vertical Display	350	11.122 ms
D	Vertical F-Porch	37	1.176 μs
E	Vertical Total	449	14.268 ms

7-5) Vertical Display Position

Mode	Hsync	Vsync	V-Start Position	V-Display	Remark
VGA-480	Positive / Negative	Positive / Negative	34	480 lines	
VGA-400	Negative	Positive	17	400 lines	Note 7-5
VGA-350	Positive	Negative	30	350 lines	Note 7-6

Note 7-5 :As the format is VGA-400 (Hsync = Negative , Vsync = Positive) , LCD module will adjust the display area to the center of display . At this time , both of the upper and lower display areas have 40 blanking lines (the display color is black) . The actual display area is center 400 lines .

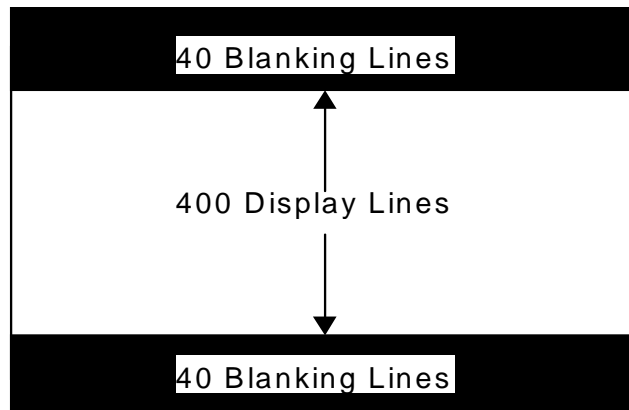

Note 7-6 : As the format is VGA-350 (Hsync = Positive, Vsync = Negative) , LCD module will adjust the display area to the center of display . At this time , both of the upper and lower display areas have 65 blanking lines (the display color is black) . The actual display area is center 350 lines .

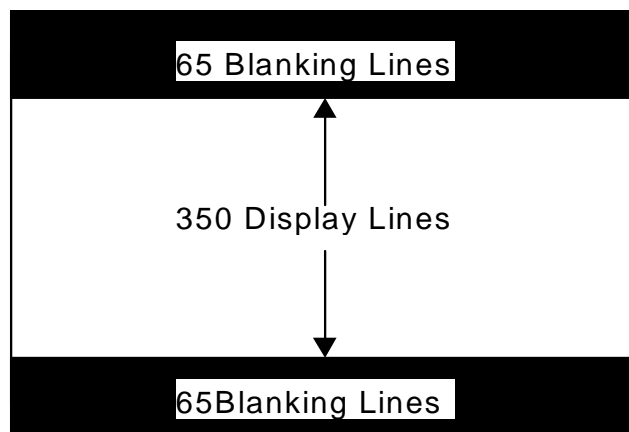

7-6) Display Color and Gray Scale Reference

Color		Input Color Data																	
		Red					Green						Blue						
		R5	R4	R3	R2	R1	R0	G5	G4	G3	G2	G1	G0	B5	B4	B3	B2	B1	B0
Basic Colors	Black	0	0	0	0	0	0	0	0	0	0	0	0	0	0	0	0	0	0
	Red (63)	1	1	1	1	1	1	0	0	0	0	0	0	0	0	0	0	0	0
	Green (63)	0	0	0	0	0	0	1	1	1	1	1	1	0	0	0	0	0	0
	Blue (63)	0	0	0	0	0	0	0	0	0	0	0	0	1	1	1	1	1	1
	Cyan	0	0	0	0	0	0	1	1	1	1	1	1	1	1	1	1	1	1
	Magenta	1	1	1	1	1	1	0	0	0	0	0	0	1	1	1	1	1	1
	Yellow	1	1	1	1	1	1	1	1	1	1	1	1	0	0	0	0	0	0
	White	1	1	1	1	1	1	1	1	1	1	1	1	1	1	1	1	1	1
Red	Red (00)	0	0	0	0	0	0	0	0	0	0	0	0	0	0	0	0	0	0
	Red (01)	0	0	0	0	0	1	0	0	0	0	0	0	0	0	0	0	0	0
	Red (02)	0	0	0	0	1	0	0	0	0	0	0	0	0	0	0	0	0	0
	Darker																		
	↓	↓	↓	↓	↓	↓	↓	↓	↓	↓	↓	↓	↓	↓	↓	↓	↓	↓	↓
	Brighter																		
	Red (61)	1	1	1	1	0	1	0	0	0	0	0	0	0	0	0	0	0	0
	Red (62)	1	1	1	1	1	0	0	0	0	0	0	0	0	0	0	0	0	0
Red (63)	1	1	1	1	1	1	0	0	0	0	0	0	0	0	0	0	0	0	
Green	Green (00)	0	0	0	0	0	0	0	0	0	0	0	0	0	0	0	0	0	0
	Green (01)	0	0	0	0	0	0	0	0	0	0	0	1	0	0	0	0	0	0
	Green (02)	0	0	0	0	0	0	0	0	0	0	1	0	0	0	0	0	0	0
	Darker																		
	↓	↓	↓	↓	↓	↓	↓	↓	↓	↓	↓	↓	↓	↓	↓	↓	↓	↓	↓
	Brighter																		
	Green (61)	0	0	0	0	0	0	1	1	1	1	0	1	0	0	0	0	0	0
	Green (62)	0	0	0	0	0	0	1	1	1	1	1	0	0	0	0	0	0	0
Green (63)	0	0	0	0	0	0	1	1	1	1	1	1	0	0	0	0	0	0	
Blue	Blue (00)	0	0	0	0	0	0	0	0	0	0	0	0	0	0	0	0	0	0
	Blue (01)	0	0	0	0	0	0	0	0	0	0	0	0	0	0	0	0	0	1
	Blue (02)	0	0	0	0	0	0	0	0	0	0	0	0	0	0	0	0	1	0
	Darker																		
	↓	↓	↓	↓	↓	↓	↓	↓	↓	↓	↓	↓	↓	↓	↓	↓	↓	↓	↓
	Brighter																		
	Blue (61)	0	0	0	0	0	0	0	0	0	0	0	0	1	1	1	1	0	1
	Blue (62)	0	0	0	0	0	0	0	0	0	0	0	0	1	1	1	1	1	0
Blue (63)	0	0	0	0	0	0	0	0	0	0	0	0	1	1	1	1	1	1	

7-7) Control Board Dip Switch Format
SW1(8 Pins)

Item	Symbol	Condition	Remark
SW 1-1	-	No connection	Default (OFF)
SW 1-2	HP3	Horizontal Shift (8 Line)	Default (ON)
SW 1-3	HP2	Horizontal Shift (4 Line)	Default (OFF)
SW 1-4	HP1	Horizontal Shift (2 Line)	Default (OFF)
SW 1-5	HP0	Horizontal Shift (1 Line)	Default (ON)
SW 1-6	VP2	Vertical Shift (4 Line)	Default (OFF)
SW 1-7	VP1	Vertical Shift (2 Line)	Default (ON)
SW 1-8	VP0	Vertical Shift (1Line)	Default (ON)

1. The default state is base on SYNC. mode (VGA-480)
2. Total horizontal shift line are 15 lines (HP0~HP3 on)
Total vertical shift line are 7 lines (VP0~VP2 on)

SW2 (2 Pins)

Item	Symbol	Condition	Remark
SW 2-1	UD	Vertical Image Shift-direction Select	Default (ON)
SW 2-2	RL	Horizontal Image Shift-direction Select	Default (ON)

8. Power On Sequence

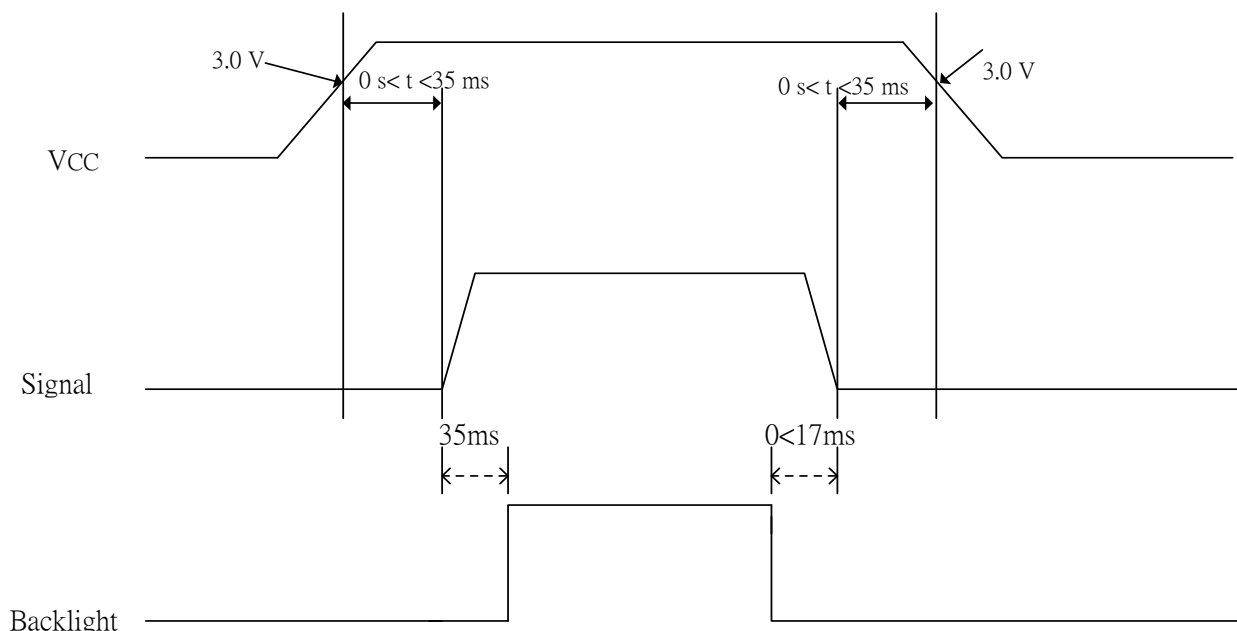

1. The supply voltage for input signals should be same as V_{CC} .
2. When the power is off , please keep whole signals (Hsync, Vsync, CLK, Data) low level or high impedance

9. Optical Characteristic

9-1) Specification:

Ta=25°C

Parameter		Symbol	Condition	MIN.	TYP.	MAX.	Unit	Remarks
Viewing Angle	Horizontal	$\theta 21, \theta 22$	CR > 10	55	60	-	deg	Note 9-1
	Vertical	$\theta 12$		35	40	-	deg	
		$\theta 11$		50	55	-	deg	
Contrast Ratio		CR	At optimized Viewing angle	200	400	-	-	Note 9-2
Brightness		L	$\theta = 0^\circ$	350	400	-	cd/m ²	Note 9-3
LED Life Time			+25°C	20000	30000	-	hr	Note 9-4
Response time	Rise	Tr	$\theta = 0^\circ$	-	15	30	ms	Note 9-5
	Fall	Tf		-	25	50	ms	
Uniformity		U	-	75	80	-	%	Note 9-6
Cross Talk		-	$\theta = 0^\circ$	-	-	3.5	%	Note 9-7
White Chromaticity		x	$\theta = 0^\circ$	0.27	0.31	0.35	-	
		y		0.29	0.33	0.37	-	

Note 9-1 : The definitions of viewing angle diagrams :

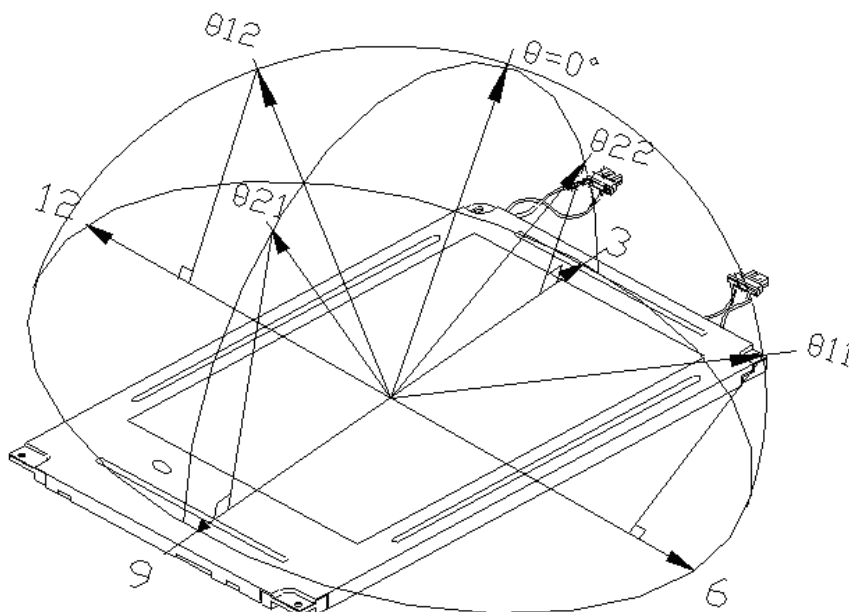

Note 9-2 : The definition of contrast ratio $CR = \frac{\text{Luminance at gray level 63}}{\text{Luminance at gray level 0}}$

Note 9-3 : Topcon BM-7 (fast) luminance meter 1° field of view is used in the testing

Note 9-4: The “LED Life time “ is defined as the module brightness decrease to 50% original Brightness that the ambient temperature is 25°C and I_{LED} =140mA.

Note 9-5 : The definitions of response time

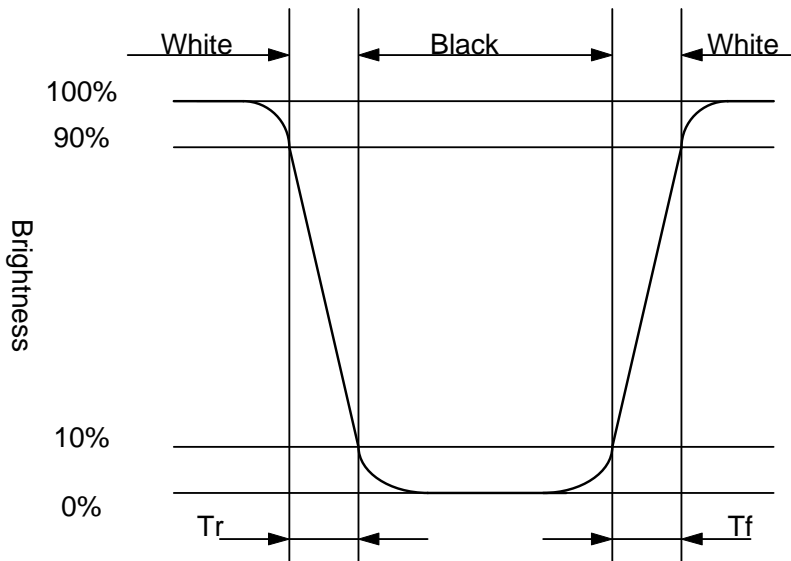

Note 9-6 : The uniformity of LCD is defined as

$$U = \frac{\text{The Minimum Brightness of the 9 testing Points}}{\text{The Maximum Brightness of the 9 testing Points}}$$

The Maximum Brightness of the 9 testing Points

Luminance meter : BM-5A or BM-7 fast (TOPCON)

Measurement distance : 500 mm +/- 50 mm

Ambient illumination : < 1 Lux

Measuring direction : Perpendicular to the surface of module

The test pattern is white (Gray Level 63).

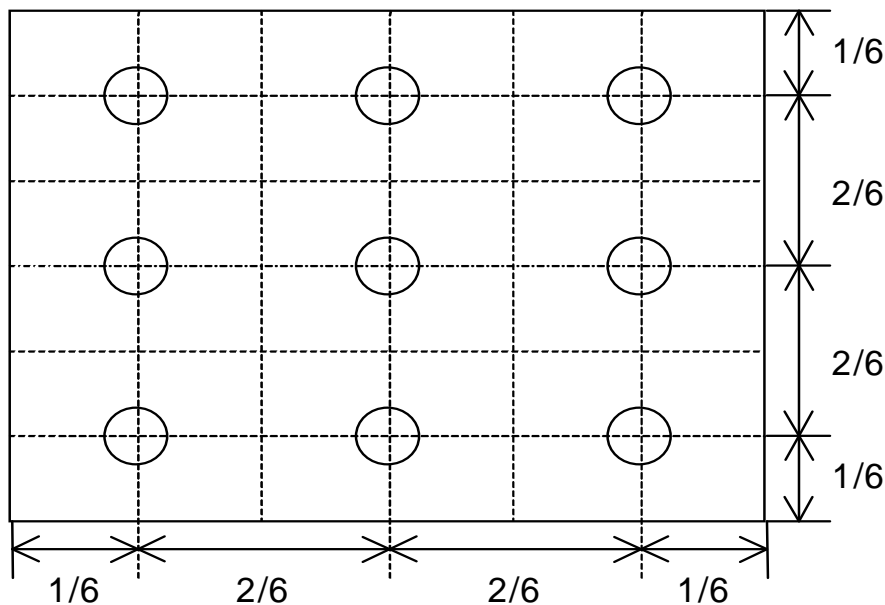

Note 9-7 : Cross Talk (CTK) = $\frac{|YA-YB|}{YA} \times 100\%$

YA : Brightness of Pattern A

YB : Brightness of Pattern B

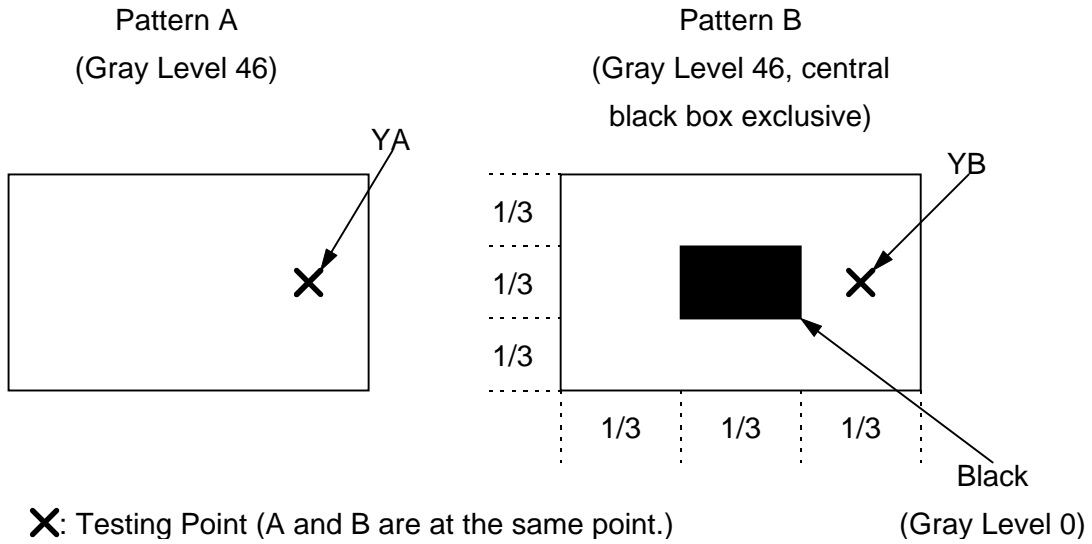

10. Handling Cautions

10-1) Mounting of module

- a) Please power off the module when you connect the input/output connector.
- b) Polarizer which is made of soft material and susceptible to flaw must be handled carefully.
- c) Protective film (Laminator) is applied on surface to protect it against scratches and dirt.
- d) Please follow the tear off direction as figure 10-1 to remove the protective film as slowly as possible, so that electrostatic charge can be minimized.

10-2) Precautions in mounting

- a) When metal part of the TFT-LCD module (shielding lid and rear case) is soiled, wipe it with soft dry cloth.
- b) Wipe off water drops or finger grease immediately. Long contact with water may cause discoloration or spots.
- c) TFT-LCD module uses glass, which breaks or cracks easily if dropped or bumped on hard surface. Please handle with care.
- d) Since CMOS LSI is used in the module. So take care of static electricity and earth yourself when handling.

10-3) Adjusting module

- a) Adjusting volumes on the rear face of the module have been set optimally before shipment.
- b) Therefore, do not change any adjusted values. If adjusted values are changed, the specifications described may not be satisfied.

10-4) Others

- a) Do not expose the module to direct sunlight or intensive ultraviolet rays for many hours.
- b) Store the module at a room temperature place.
- c) The voltage of beginning electric discharge may over the normal voltage because of leakage current from approach conductor by to draw lump read lead line around.
- d) If LCD panel breaks, it is possibly that the liquid crystal escapes from the panel. Avoid putting it into eyes or mouth. When liquid crystal sticks on hands, clothes or feet. Wash it out immediately with soap.
- e) Observe all other precautionary requirements in handling general electronic components.
- f) Please adjust the voltage of common electrode as material of attachment by 1 module.

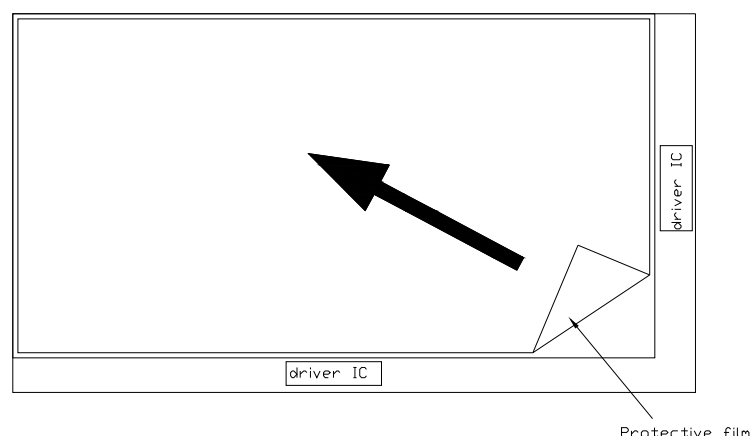

Figure 10-1 the way to peel off protective film

11. Reliability Test

No	Test Item	Test Condition
1	High Temperature Storage Test	Ta = +80 °C, 240 hrs
2	Low Temperature Storage Test	Ta = -30 °C, 240 hrs
3	High Temperature Operation Test	Ta = +80 °C, 240 hrs
4	Low Temperature Operation Test	Ta = -30 °C, 240 hrs
5	High Temperature & High Humidity Operation Test	Ta = +60 °C, 90%RH, 240 hrs
6	Thermal Cycling Test (non-operating)	-25°C → +70°C, 200 Cycles 30 min 30 min
7	Shock Test (non-operating)	Gravity: 490m/s Direction: ±X, ±Y, ±Z Pulse Width: 11ms, half sine wave
8	Vibration Test (non-operating)	Frequency : 10 ~ 57 Hz/Vibration Width :0.075mm 58-500 H// Gravity: 19.6m/s(2G) Sweep time: 11 minutes Test period: 3 hrs for each direction of X, Y, Z
9	Electrostatic Discharge Test (non-operating)	150pF, 330Ω Air : ±15KV ; Contact : ±8KV 10 times/point , 9 points/panel face

Ta: ambient temperature

Note: The protective film must be removed before temperature test.

[Criteria]

In the standard conditions, there is not display function NG issue occurred. (Including: line defect, no image). All the cosmetic specification is judged before the reliability stress.

12. Block Diagram

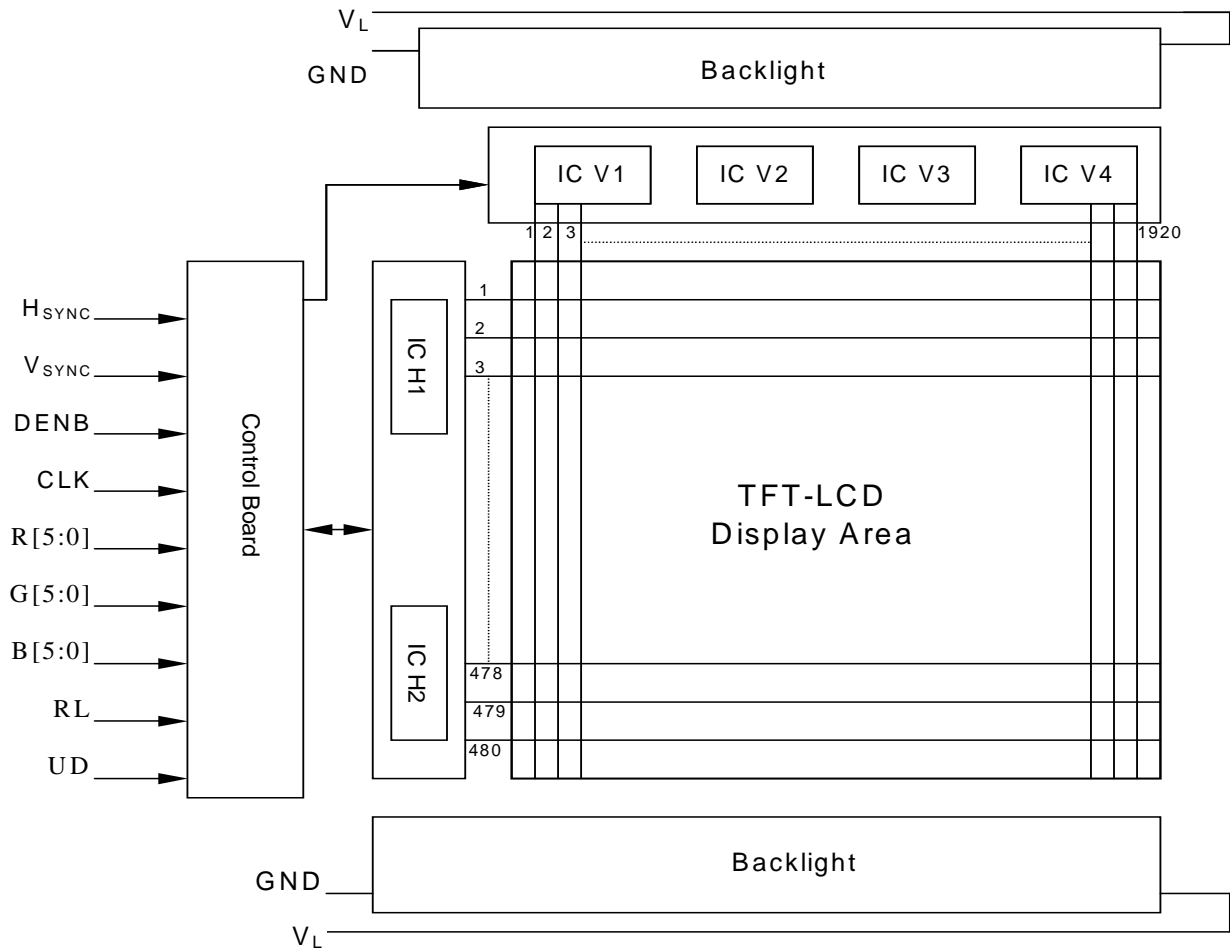

13. Packing

ZONE	REV.	DOCUMENT NO.	DESCRIPTION	DATE	REV. BY																									
<p>NOTE:</p> <p>1.Q'TY: 20 pcs panel/carton. 2.Dimension: 530*295*230mm 3.Weight: 9.1 Kg</p>																														
		<table border="1" style="width:100%; border-collapse: collapse;"> <thead> <tr> <th>ITEM</th> <th>PART NO.</th> <th>DESCRIPTION</th> <th>QTY</th> <th>REMARK</th> </tr> </thead> <tbody> <tr> <td>4</td> <td>50-0100111</td> <td>CARTON</td> <td>1</td> <td></td> </tr> <tr> <td>3</td> <td>50-0500131</td> <td>防静电气泡袋 Pink</td> <td>20</td> <td>防静电</td> </tr> <tr> <td>2</td> <td></td> <td>6.4" VGA Module</td> <td>20</td> <td>加下鐵蓋</td> </tr> <tr> <td>1</td> <td>50-0301041</td> <td>瓦楞隔板緩衝材</td> <td>1</td> <td>上蓋+底座</td> </tr> </tbody> </table>		ITEM	PART NO.	DESCRIPTION	QTY	REMARK	4	50-0100111	CARTON	1		3	50-0500131	防静电气泡袋 Pink	20	防静电	2		6.4" VGA Module	20	加下鐵蓋	1	50-0301041	瓦楞隔板緩衝材	1	上蓋+底座		
ITEM	PART NO.	DESCRIPTION	QTY	REMARK																										
4	50-0100111	CARTON	1																											
3	50-0500131	防静电气泡袋 Pink	20	防静电																										
2		6.4" VGA Module	20	加下鐵蓋																										
1	50-0301041	瓦楞隔板緩衝材	1	上蓋+底座																										
MTL.SPEC.		UNSPECIFIED TOL'S		REMARK																										
		ANGLE																												
		ROUGHNESS																												
APPROVE	Franks	'04.10.12	SCALE	UNIT	SHEET																									
CHECK	Franks	'04.10.12			1 OF 1																									
DRAWN	Jimmy	'04.10.12	MTL.NO.		DWG.TITLE																									
					6.4"VGA Module Packing Draw																									
				DWG FILE:	REV. 01																									
					A4 SIZE																									