

# OXY5316A

3.5" Single Board Computer  
User's Manual

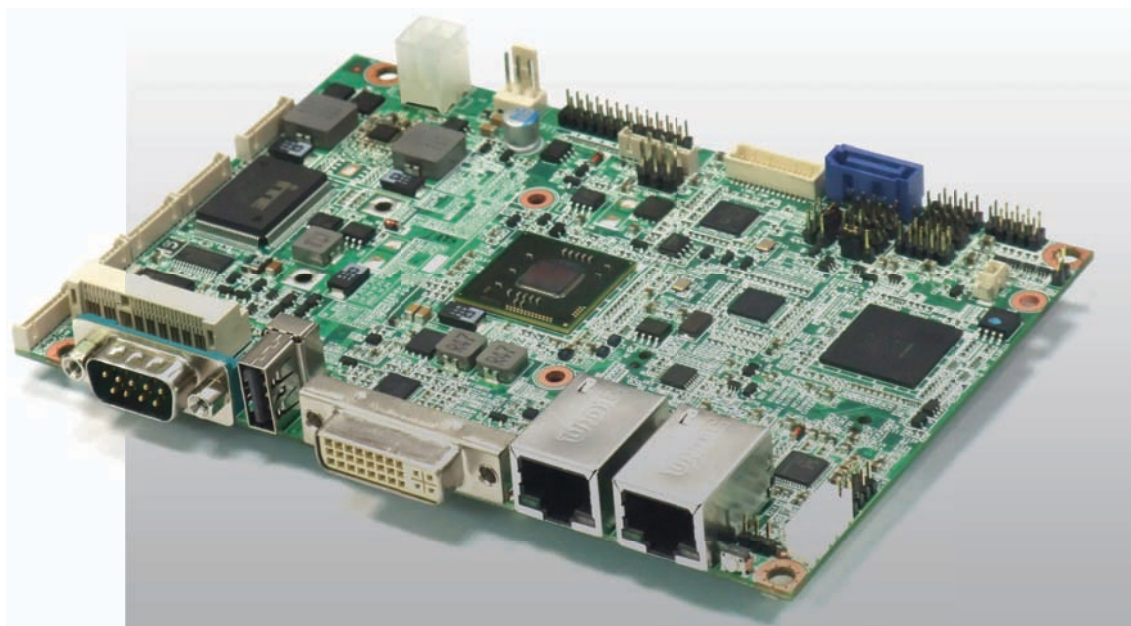

## Safety Information

### Electrical safety

- To prevent electrical shock hazard, disconnect the power cable from the electrical outlet before relocating the system.
- When adding or removing devices to or from the system, ensure that the power cables for the devices are unplugged before the signal cables are connected. If possible, disconnect all power cables from the existing system before you add a device.
- Before connecting or removing signal cables from the motherboard, ensure that all power cables are unplugged.
- Seek professional assistance before using an adapter or extension cord. These devices could interrupt the grounding circuit.
- Make sure that your power supply is set to the correct voltage in your area.
- If you are not sure about the voltage of the electrical outlet you are using, contact your local power company.
- If the power supply is broken, do not try to fix it by yourself. Contact a qualified service technician or your local distributor.

### Operation safety

- Before installing the motherboard and adding devices on it, carefully read all the manuals that came with the package.
- Before using the product, make sure all cables are correctly connected and the power cables are not damaged. If you detect any damage, contact your dealer immediately.
- To avoid short circuits, keep paper clips, screws, and staples away from connectors, slots, sockets and circuitry.
- Avoid dust, humidity, and temperature extremes. Do not place the product in any area where it may become wet.
- Place the product on a stable surface.
- If you encounter any technical problems with the product, contact your local distributor

### Statement

- All rights reserved. No part of this publication may be reproduced in any form or by any means, without prior written permission from the publisher.
- All trademarks are the properties of the respective owners.
- All product specifications are subject to change without prior notice

**Revision History**

Revision	Date (dd.mm.yyyy)	Changes
Version 1.0	28.05.2012	Initial release

**Packing list**

- OXY5316A 3.5" SBC
- CD (Driver + user's manual)
- Cable Kit (optional)



If any of the above items is damaged or missing, please contact your local distributor.

## Table of Contents

<b>Safety Information .....</b>	<b>1</b>
<i>Electrical safety.....</i>	<i>1</i>
<i>Operation safety .....</i>	<i>1</i>
<i>Statement .....</i>	<i>1</i>
<i>Revision History.....</i>	<i>2</i>
<i>Packing list .....</i>	<i>2</i>
<b>Chapter 1: Product Information .....</b>	<b>5</b>
1.1 <i>Block Diagram.....</i>	<i>5</i>
1.2 <i>Key Features.....</i>	<i>6</i>
1.3 <i>Board Placement.....</i>	<i>7</i>
1.4 <i>Onboard Connector List .....</i>	<i>8</i>
1.5 <i>Mechanical Drawings.....</i>	<i>9</i>
<b>Chapter 2: Jumpers and Connectors.....</b>	<b>10</b>
2.1 <i>Jumper Settings.....</i>	<i>10</i>
PERSON1: ATX/AT mode Selection .....	10
2.2 <i>Connector Pin Definitions.....</i>	<i>10</i>
ATX1: Power input connector.....	10
FAN: 3 pin FAN connector .....	10
LPT1: LPT port pin header .....	11
LVDS_CON: LVDS Connector.....	11
JBKL1: Inverter connector .....	12
KBMS1: KB/MS Pin Header .....	12
FP1: Front Panel 1 Pin Header.....	12
USB1, USB2, USB3: USB2.0 Pin Header .....	12
RUSB1: USB2.0 port 6 connector .....	13
DIO1: Digital input/output pin header .....	13
AUDIO1: LINE-OUT/LINE-IN/MIC-IN .....	13
SPDIF1: SPDIF OUT pin header.....	13
AMP1: AMP output pin header.....	13
LAN1, LAN2: LAN connector .....	14
DVI: DVI-I connector.....	14
COM1: RS232/422/485 with +12V/+5V selection .....	15
COM2, COM3, COM4: RS232 with +12V/+5V selection (1x10 pin Wafer) .....	15
COM5: RS232 .....	15
MPCIE1: Mini PCIE connector .....	16
DEBUG: Debug card connector .....	16
BAT1: RTC battery connector .....	16
CFAST: CFAST connector .....	17
SATA1: Serial ATA 2.0 Connector .....	17
<b>Chapter 3: Getting Started .....</b>	<b>18</b>
3.1 <i>Installing System Memory.....</i>	<i>18</i>
3.2 <i>installing the CF card.....</i>	<i>18</i>

<b>Chapter 4: AMI BIOS UTILITY .....</b>	<b>19</b>
4.1 Starting .....	19
4.2 Navigation Keys .....	19
4.3 Main Menu .....	20
4.4 Advanced Menu .....	20
4.4.1 PCI Subsystem Settings .....	21
4.4.2 ACPI Settings .....	21
4.4.3 Trusted Computing .....	22
4.4.4 CPU Configuration .....	22
4.4.5 Thermal Configuration .....	23
4.4.6 IDE Configuration .....	24
4.4.7 Intel Fast Flash Standby .....	24
4.4.8 USB Configuration .....	25
4.4.9 SMART Settings .....	26
4.4.10 Super IO Configuration .....	26
4.4.11 Smart Fan Function .....	27
4.4.12 H/W Monitor .....	27
4.4.13 AOAC Configuration .....	28
4.4.14 Demo Board .....	28
4.4.15 Serial Port Console Redirection .....	28
4.4.16 PPM Configuration .....	29
4.5 Chipset .....	29
4.6 Boot Setting .....	31
4.7 Security .....	32
4.8 Save and exit .....	33

## Chapter 1: Product Information

### 1.1 Block Diagram

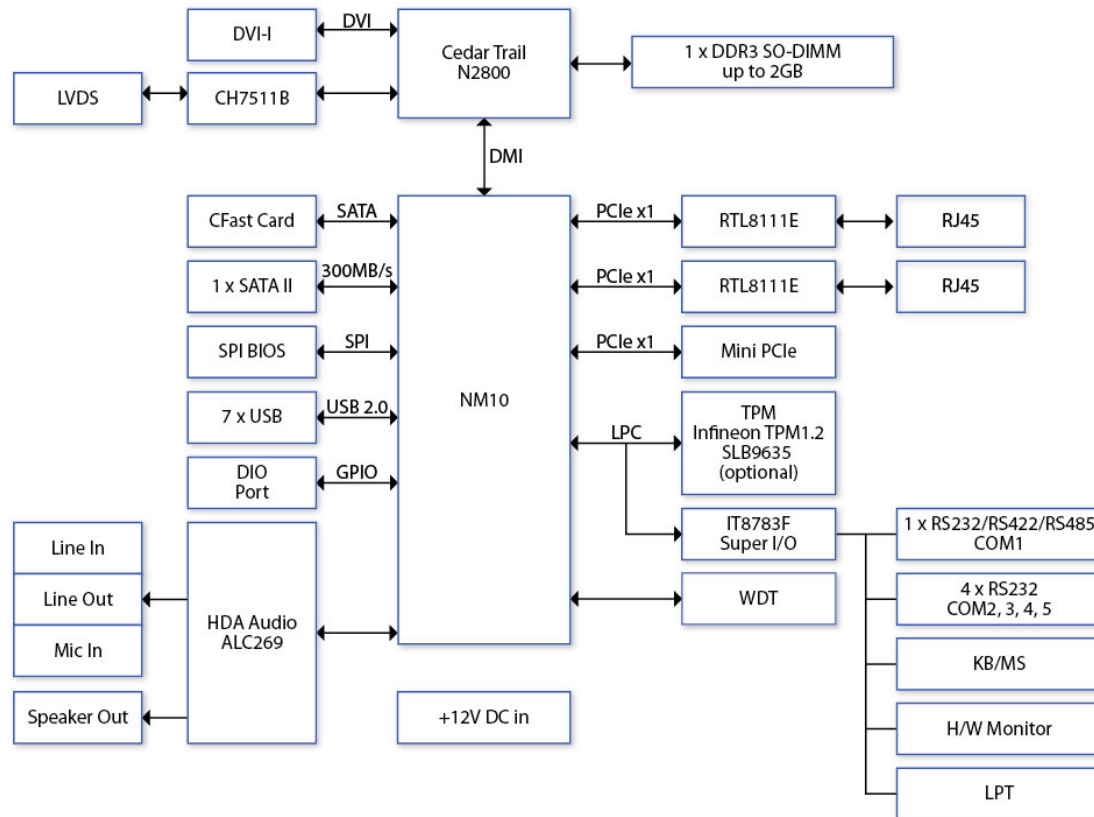

## 1.2 Key Features

Processor & System	
CPU Type	Intel® Atom™ N2800 1.86GHz onboard
Chipset	Intel® NM10
Memory Type	1 x 204 pin SO-DIMM DDR3 800/1066 up to 2GB
BIOS	AMI® BIOS
Super I/O	ITE IT8783F
TPM	Infineon TPM1.2 SLB9635 (optional)
Expansion Slot	
Expansion Slot	1 x Mini PCIe Slot
Display	
Chipset	Integrated Intel® GMA3650 VR Graphic core SGX545
DVI-I	Yes (Max. resolution 1920 x 1200 @60Hz)
LVDS	Supports 18/24-bit single/dual channel LVDS (Max. resolution 1366 x 768 @60Hz)
Dual Independent Displays Capability	LVDS + DVI-I
Audio	
Codec	Realtek ALC269 High Definition Audio Codec *2W amplifier onboard
Ethernet	
Chipset	2 x RTL8111E GbE LAN
WOL	Yes
Boot from LAN	Yes for PXE
Rear I/O	
DVI-I	1
Ethernet	2 x RJ45
USB 1.1/2.0	1
COM	1 x RS-232/422/485 with 5V/12V selection
Reset Button	1
Internal I/O	
SATA	1 x SATAII (3Gb/s)
SSD	1 x CFast Socket
USB 2.0	7 x USB 1.1/2.0 • 1 port on rear I/O • 6 ports by 2 x 5 pin header
COM	5 x COM ports • COM1 port supports RS232/422/485 with 5V/12V • COM2~COM4 ports by 1x10 pin header • COM5 port by 1x10 pin box header and
Audio	2 x 4 pin header for Line-in/Mic-in/Line-out 1 x 4 pin Speak-out
LVDS	30 pin connector
PS/2	2 x 4 pin header
LPT	2 x 13 pin header
DIO	4 in/4 out

Mechanical and Environment	
Form Factor	3.5" SBC
Power Type	+12V DC-in, 4-pin ATX power connector, AT/ATX mode support (optional for terminal block connector)
Dimension	146mm x 102mm (5.7" x 4")
Operating Temp.	-20°C ~ +70°C
Storage Temp.	-40°C ~ +80°C
Relative Humidity	10% to 90%, non-condensing

\* All specifications and photos are subject to change without notice\*

### 1.3 Board Placement

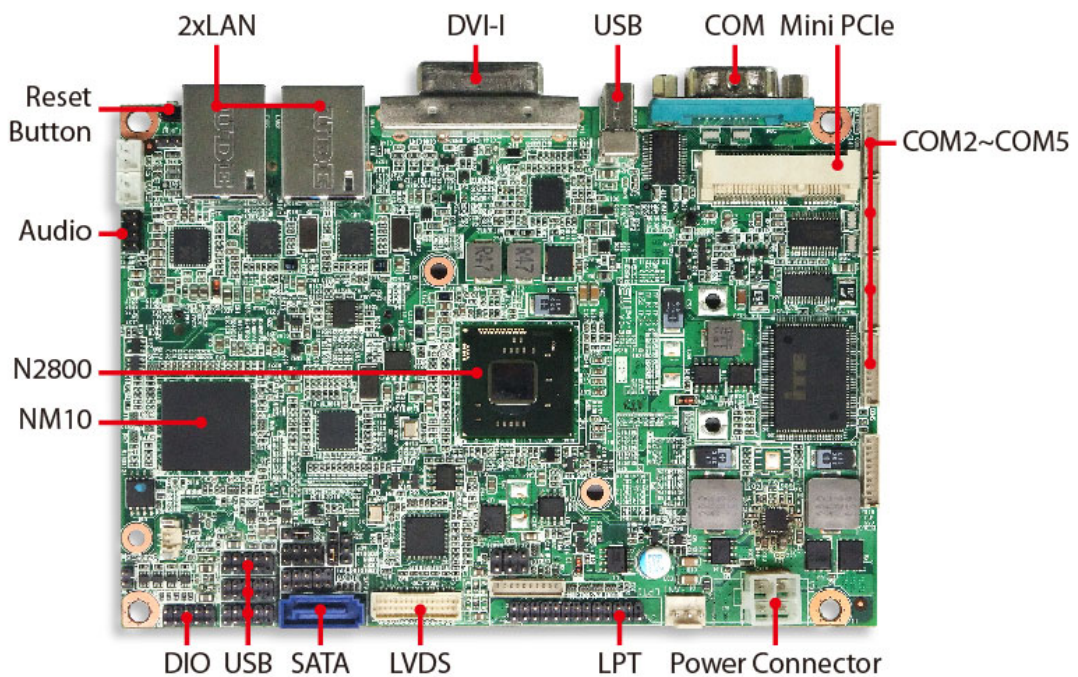



## 1.4 Onboard Connector List

Label	Function
ATX1	Power input connector
FAN1	3 pin FAN connector
LPT1	LPT port pin header
LVDS_CON	LVDS connector
JBKL1	Inverter connector
KBMS1	PS2 KB/MS
FP1	Front panel 1
FP2	Front panel 2
USB1	USB2.0 port 0,1 pin header
USB2	USB2.0 port 2,3 pin header
USB3	USB2.0 port 4,5 pin header
RUSB1	USB2.0 port 6 connector
DIO1	Digital input/output pin header
AUDIO1	LINE-OUT/LINE-IN/MIC-IN
SPDIF1	SPDIF OUT
AMP1	AMP output pin header
LAN1	LAN connector 1
LAN2	LAN connector 2
DVI	DVI-I
COM1	RS232/422/485 with +12V/+5V selection
COM2	RS232 with +12V/+5V selection
COM3	RS232 with +12V/+5V selection
COM4	RS232 with +12V/+5V selection
COM5	RS232
MPCIE1	Mini PCIE connector
DEBUG	Debug card connector
BAT1	RTC battery connector
CFAST	CFAST connector
DDR3_1	DDR3 SO-DIMM connector
SATA1	Serial ATA 2.0 Connector

### 1.5 Mechanical Drawings

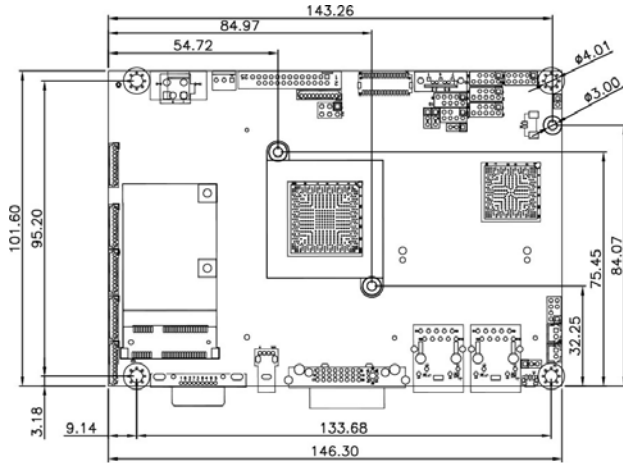

TOP VIEW

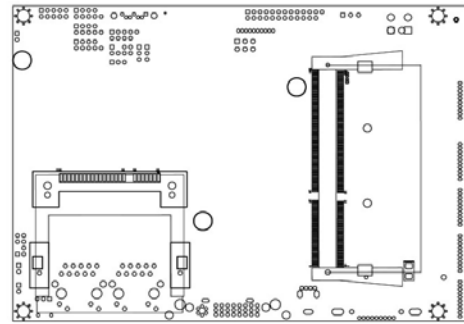

BOTTOM VIEW

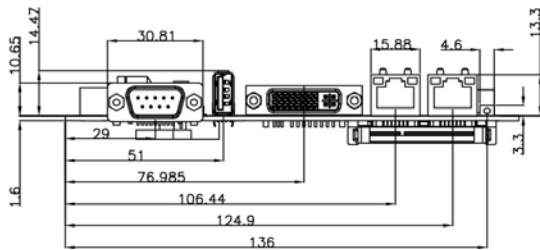

## Chapter 2: Jumpers and Connectors

### 2.1 Jumper Settings

#### PSON1: ATX/AT mode Selection

Jumper	Function description	Setting				
1-2	AT Mode	<table border="1"> <tr><td>1</td><td><input type="checkbox"/></td></tr> <tr><td>3</td><td><input type="checkbox"/></td></tr> </table>	1	<input type="checkbox"/>	3	<input type="checkbox"/>
1	<input type="checkbox"/>					
3	<input type="checkbox"/>					
2-3	ATX Mode	<table border="1"> <tr><td>1</td><td><input type="checkbox"/></td></tr> <tr><td>3</td><td><input type="checkbox"/></td></tr> </table>	1	<input type="checkbox"/>	3	<input type="checkbox"/>
1	<input type="checkbox"/>					
3	<input type="checkbox"/>					

\*Default setting is 2-3\*

### 2.2 Connector Pin Definitions

#### ATX1: Power input connector

Pin	Definition
1	GND
2	GND
3	+12V
4	+12V

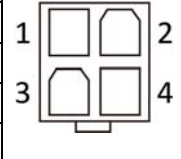

#### FAN: 3 pin FAN connector

Pin	Definition
1	GND
2	+12V
3	FANIN_CPU

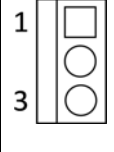

**LPT1: LPT port pin header**

Pin	Definition	Pin	Definition
1	STB#	2	AFD#
3	SPD0	4	ERROR#
5	SPD1	6	PINIT#
7	SPD2	8	SLIN#
9	SPD3	10	GND
11	SPD4	12	GND
13	SPD5	14	GND
15	SPD6	16	GND
17	SPD7	18	GND
19	ACK#	20	GND
21	BUSY	22	GND
23	PE	24	GND
25	SLCT	26	NC

**LVDS\_CON: LVDS Connector**

Pin	Definition	Pin	Definition
1	LVDS_BCLK	2	GND
3	LVDS_BCLK#	4	LVDS_A3
5	GND	6	LVDS_A3#
7	LVDS_B3	8	GND
9	LVDS_B3#	10	LVDS_ACLK
11	LVDS_B2	12	LVDS_ACLK #
13	LVDS_B2#	14	GND
15	LVDS_B1	16	LVDS_A2
17	LVDS_B1#	18	LVDS_A2#
19	LVDS_B0	20	LVDS_A1
21	LVDS_B0#	22	LVDS_A1#
23	GND	24	LVDS_A0
25	LVDS_DCC_SC	26	LVDS_A0#
27	LVDS_DCC_SD	28	GND
29	LVDS_VDD	30	LVDS_VDD

**JBKL1: Inverter connector**

Pin	Definition
1	VCC12_LVDSP
2	VCC12_LVDSP
3	VCC12_LVDSP
4	VCC_LVDSP
5	VCC_LVDSP
6	GND
7	GND
8	BL_EN
9	BL_ADJ
10	GND

**KBMS1: KB/MS Pin Header**

Pin	Definition	Pin	Definition
1	+5VSB	2	GND
3	NC	4	GND
5	MSDAT_SIO	6	KBDAT_SIO
7	MSCLK_SIO	8	KBCLK_SIO

**FP1: Front Panel 1 Pin Header**

Pin	Definition	Pin	Definition
1	HDLED+	2	PLED+
3	HDD_ACT_	4	PLED-
5	GND	6	PWRBTN_
7	YSRST_	8	GND
9	DUMMY	10	NC

**USB1, USB2, USB3: USB2.0 Pin Header**

Pin	Definition	Pin	Definition
1	FUSEVCC	2	FUSEVCC
3	USBN	4	USBN
5	USBP	6	USBP
7	GND	8	GND
9	NC	10	GND

**RUSB1: USB2.0 port 6 connector**

Pin	Definition
1	+5V
2	USBN
3	USBP
4	GND

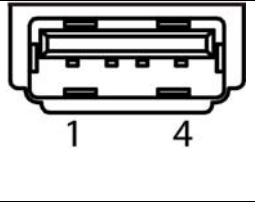

**DIO1: Digital input/output pin header**

Pin	Definition	Pin	Definition
1	SBDO0	2	SBDIO
3	SBDO1	4	SBDI1
5	SBDO2	6	SBDI2
7	SBDO3	8	SBDI3
9	+5VIO	10	GND

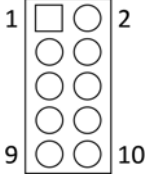

**AUDIO1: LINE-OUT/LINE-IN/MIC-IN**

Pin	Definition	Pin	Definition
1	L_IN_L	2	L_IN_R
3	NC	4	AGND
5	MIC_IN	6	AGND
7	L_OUT_R	8	L_OUT_L

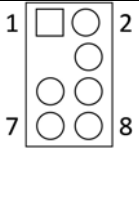

**SPDIF1: SPDIF OUT pin header**

Pin	Definition
1	+5V
2	SPDIF_OUT
3	GND

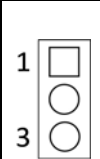

**AMP1: AMP output pin header**

Pin	Definition
1	SP_OUT_R-
2	SP_OUT_R+
3	SP_OUT_L+
4	SP_OUT_L-

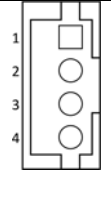

**LAN1, LAN2: LAN connector**

Pin	Definition	Pin	Definition
R5	VCC	R6	VCC
R1	TD1+	L3	YLED-
R2	TD1-	L4	YLED+
R3	TD2+	L1	GLED-
R4	TD2-	L2	OLED-
R7	TD3+	G3	GND
R8	TD3-	G4	GND
R9	TD4+		
R10	TD4-		
G1	GND		
G2	GND		

**SPEED LED: (Right)**  
 1. GREEN : 100Mbps  
 2. ORANGE : 100Mbps  
 3. No Light : 10Mbps

**ACTIVE LED: (Left)**  
 1. GREEN(BLINKING):ACTIVITY  
 2.No Light:NOT LINK  
 3.GREEN(NO BLINKING):LINK

**DVI: DVI-I connector**

Pin	Definition	Pin	Definition
1	TMDS Data2-	16	Hot Plug Detect
2	TMDS Data2+	17	TMDS Data0-
3	TMDS Data2/4 Shield	18	TMDS Data0+
4	TMDS Data4-	19	TMDS Data0/5 Shield
5	TMDS Data4+	20	TMDS Data5-
6	DDC Clock	21	TMDS Data5+
7	DDC Data	22	TMDS Clock Shield
8	Analog Vert. Sync	23	TMDS Clock+
9	TMDS Data1-	24	TMDS Clock-
10	TMDS Data1+	C1	Analog Red
11	TMDS Data1/3 Shield	C2	Analog Green
12	TMDS Data3-	C3	Analog Blue
13	TMDS Data3+	C4	Analog Horiz. Sync
14	+5V Power	C5	Analog GND
15	GND		

**COM1: RS232/422/485 with +12V/+5V selection**

Pin	RS-232	RS-422	Half Duplex RS-485
1	DCD	TX-	DATA-
2	RXD	RX+	NA
3	TXD	TX+	DATA+
4	DTR	RX-	NA
5	GND	GND	GND
6	DSR	NA	NA
7	RTS	NA	NA
8	CTS	NA	NA
9	+5V/+12V/RI	+5V/+12V/NA	+5V/+12V/NA

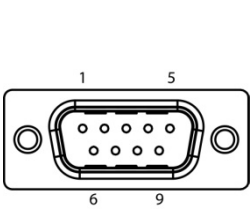

**COM2, COM3, COM4: RS232 with +12V/+5V selection (1x10 pin Wafer)**

Pin	Definition
1	+CM_P1 DCD
2	CM_DSR
3	CM_RXD
4	CM_RTS
5	CM_TXD
6	CM_CTS
7	CM_DTR
8	+CM2_P9 RI
9	GND
10	+5VIO

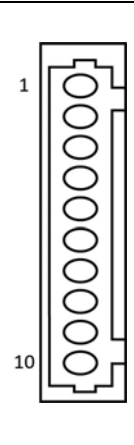

**COM5: RS232**

Pin	Definition
1	+CM_P1 DCD
2	CM_DSR
3	CM_RXD
4	CM_RTS
5	CM_TXD
6	CM_CTS
7	CM_DTR
8	+CM_P9 RI
9	GND
10	+5VIO

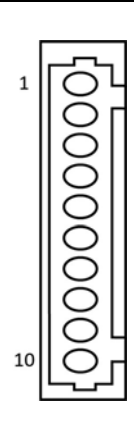



**MPCIE1: Mini PCIE connector**

Pin	Definition	Pin	Definition
1	WAKE#	2	+3.3V
3	Reserved	4	GND
5	Reserved	6	+1.5V
7	CLKREQ#	8	Reserved
9	GND	10	Reserved
11	REF CLK-	12	Reserved
13	REF CLK+	14	Reserved
15	GND	16	Reserved
17	Reserved	18	GND
19	Reserved	20	Reserved
21	GND	22	PERST#
23	PERNO	24	+3.3VAUX
25	PERPO	26	GND
27	GND	28	+1.5V
29	GND	30	SMB_CLK
31	PETNO	32	SMB_DATA
33	PETPO	34	GND
35	GND	36	USB_D-
37	Reserved	38	USB_D+
39	Reserved	40	GND
41	Reserved	42	LED_WWAN#
43	Reserved	44	LED_WLAN#
45	Reserved	46	LED_WPAN#
47	Reserved	48	+1.5V
49	Reserved	50	GND
51	Reserved	52	+3.3V

**DEBUG: Debug card connector**

Pin	Definition
1	DB_LPC_33M
2	RST_DB_R#
3	LFRAME#
4	LAD3
5	LAD2
6	LAD1
7	LAD0
8	+3.3V
9	GND
10	GND

**BAT1: RTC battery connector**

Pin	Definition
1	+3V
2	GND

**CFAST: CFAST connector**

Pin	Segment	Definition
S1	SATA	GND
S2	SATA	A+
S3	SATA	A-
S4	SATA	GND
S5	SATA	B-
S6	SATA	B+
S7	SATA	GND
	Key	
	Key	
PC1	PWR/CTL	CDI
PC2	PWR/CTL	GND
PC3	PWR/CTL	TBD1
PC4	PWR/CTL	TBD2
PC5	PWR/CTL	TBD3
PC6	PWR/CTL	TBD4
PC7	PWR/CTL	GND
PC8	PWR/CTL	LED1
PC9	PWR/CTL	LED2
PC10	PWR/CTL	IO1
PC11	PWR/CTL	IO2
PC12	PWR/CTL	IO3
PC13	PWR/CTL	3.3V
PC14	PWR/CTL	3.3V
PC15	PWR/CTL	GND
PC16	PWR/CTL	GND
PC17	PWR/CTL	CDO

**SATA1: Serial ATA 2.0 Connector**

Pin	Definition
1	GND
2	TXP
3	TXN
4	GND
5	RXN
6	RXP
7	GND

## Chapter 3: Getting Started

This chapter provides information on how to install components to the OXY5316A. Specifically, the installation of memory modules and operating system are explained.

### 3.1 Installing System Memory

The OXY5316A supports DDR3 800/1066 SO-DIMM.



Disconnect all power supplies to the board before installing a memory module to prevent damage to the board and memory module.

To install a memory module:

1. Located the memory module slots on the motherboard.
2. Push the socket retaining clips outward to unlock the slots.
3. Align the memory module with the socket to make sure the notch aligns with the slot key on the socket.
4. Insert the module firmly into the desired slot until the retaining clips lock and secure the memory module.

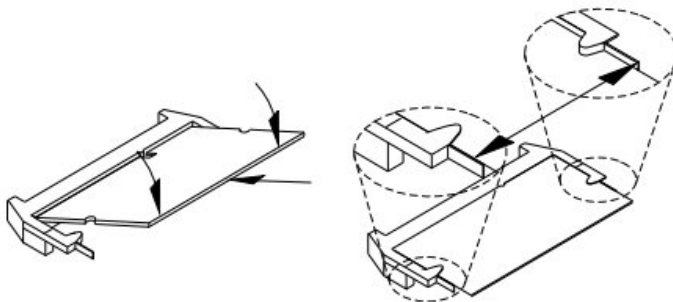

### 3.2 installing the CF card

The OXY5316A built-in CFast socket

To install a CFast card:

1. To install a CFast card into OXY5316A, align the notches on the card with the CFast socket.
2. Then firmly insert the card into the socket until it is completely seated. The label side should be facing away from the board.

## Chapter 4: AMI BIOS UTILITY

This chapter provides users with detailed descriptions on how to set up a basic system configuration through the AMI BIOS setup utility.

### 4.1 Starting

To enter the setup screens, perform the following steps:

- Turn on the computer and press the <Del> key immediately.
- After the <Del> key is pressed, the main BIOS setup menu displays. Other setup screens can be accessed from the main BIOS setup menu, such as the Chipset and Power menus.

### 4.2 Navigation Keys

The BIOS setup/utility uses a key-based navigation system called hot keys. Most of the BIOS setup utility hot keys can be used at any time during the setup navigation process. Some of the hot keys are <F1>, <F10>, <Enter>, <ESC>, and <Arrow> keys.



Some of the navigation keys may differ from one screen to another.

Left/Right	The Left and Right <Arrow> keys moves the cursor to select a menu.
Up/Down	The Up and Down <Arrow> keys moves the cursor to select a setup screen or sub-screen.
+– Plus/Minus	The Plus and Minus <Arrow> keys changes the field value of a particular setup setting.
Tab	The <Tab> key selects the setup fields.
F1	The <F1> key displays the General Help screen.
F10	The <F10> key saves any changes made and exits the BIOS setup utility.
Esc	The <Esc> key discards any changes made and exits the BIOS setup utility.
Enter	The <Enter> key displays a sub-screen or changes a selected or highlighted option in each menu.

### 4.3 Main Menu

The Main menu is the screen that first displays when BIOS Setup is entered, unless an error has occurred.



You could setup these items on the Main menu:

- System Language: Select this option to set the system language
- System Date: Select this option to set the system date.
- System Time: Select this option to set the system time.

Use the <Arrow> keys to enter the appropriate time and date. Press the <Tab> key or the <Arrow> keys to move between fields. The date setting must be entered in MM/DD/YY format. The time setting is entered in HH:MM:SS format.

#### Access Level

Displays the access level of the current user in the BIOS.

### 4.4 Advanced Menu

This section allows you to configure and improve your system and allows you to set up some system features according to your preference.

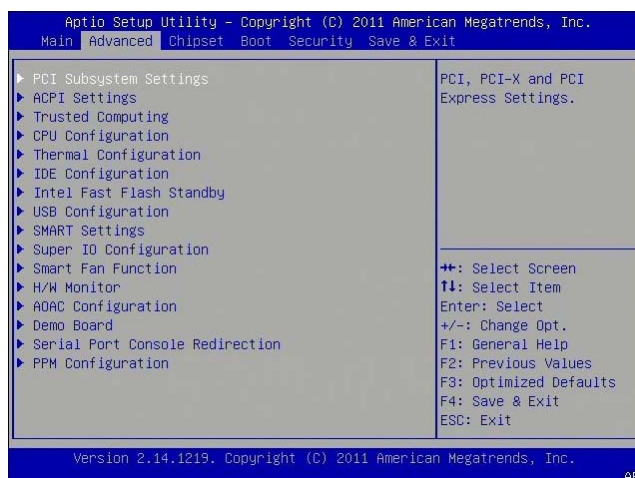

### 4.4.1 PCI Subsystem Settings

This section allows you to configure the PCI, PCI-X and PCI Express settings.



#### PCI Latency Timer

Set this value to change the PCI Bus clocks. Default is 32 PCI Bus clock

#### VGA Palette Snoop

Set this value to enable or disable the VGA Palette snoop. Default is disable

#### PERR# Generation

Set this value to enable or disable PERR# generation. Default is disable

#### SERR# Generation

Set this value to enable or disable SERR# generation. Default is disable

### 4.4.2 ACPI Settings

System ACPI Parameters.

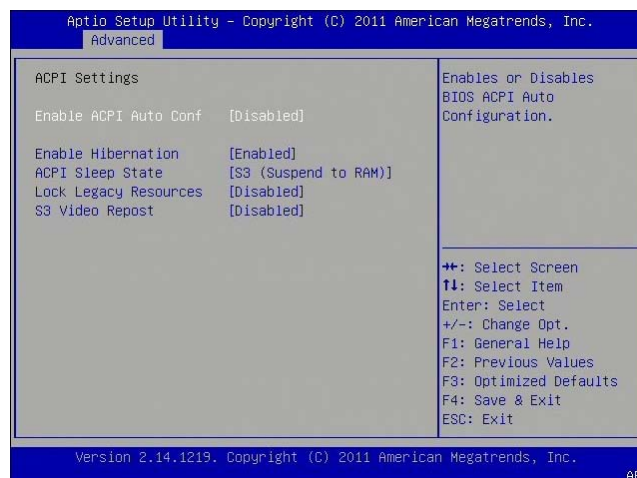

#### Enable ACPI Auto Config

Enable/disable BIOS ACPI Auto Configuration. Default is Disable

### ACPI Sleep State

Select the highest ACPI sleep state the system will enter when the SUSPEND button is Selected. The Default value is set as S3 (Suspend to RAM).

### Lock Legacy Resources

Enables or Disables System Lock of Legacy Resources.

Options: Disabled (Default) / Enabled

### S3 Video Repost

Enable or disable S3 Video Repost.

Options: Disabled (Default) / Enabled

### 4.4.3 Trusted Computing

This option allows the user to modify settings related to the optional Trusted Platform Module.

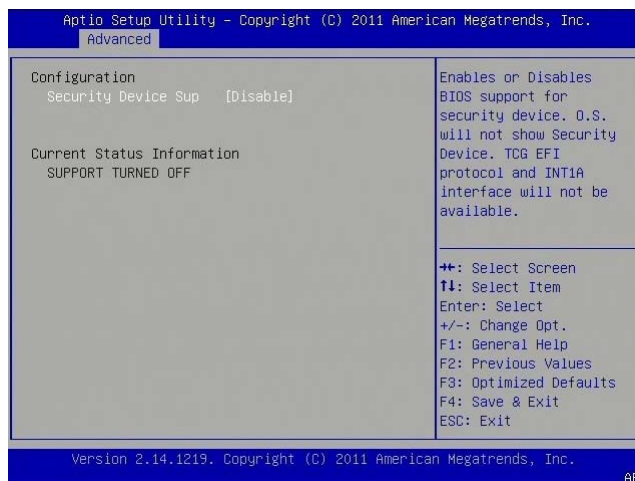

### 4.4.4 CPU Configuration

This option allows the user to view and configure the settings of the CPU installed on the computer system.

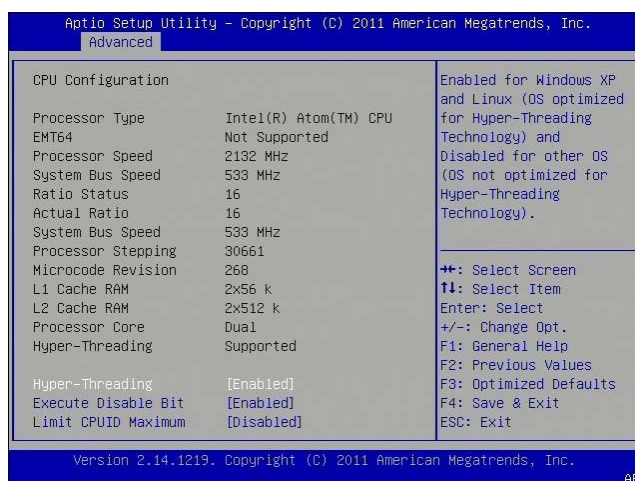

**Processor Type**

This option allows the user to view the information of the CPU installed on the hardware platform.

**Processor Speed**

This option allows the user to view the speed of the CPU installed on the hardware platform.

**System Bus Speed**

This option allows the user to view the Front Side Bus (FSB) speed of the CPU.

**Processor Stepping**

This option allows the user to view the stepping information of the CPU.

**L2 Cache RAM**

This option allows the user to view the amount of L2 Cache on the CPU.

**Hyper-Threading**

This option allows the user to enable or disable the HyperThreading™ support of the Intel® Pentium® 4 HT processor. By default this setting is enabled. This setting should be disabled in Microsoft™ Windows 2000 based systems.

**Execute Disable Bit**

XD can prevent certain classes of malicious buffer overflow attacks when combined with a supporting OS (Windows Server 2003 SP1, Windows XP SP2, SuSE Linux 9.2, RedHat Enterprise 3 Update 3.)

**Limit CPUID Maximum**

Disabled for Windows XP.

**4.4.5 Thermal Configuration**

This option allows the user to view and configure the settings of the CPU installed on the computer system.

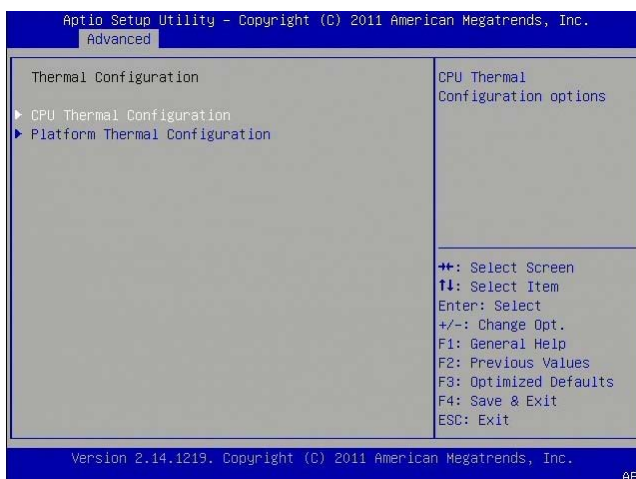



### 4.4.6 IDE Configuration

You can use this option to select options for the IDE Configuration Settings.

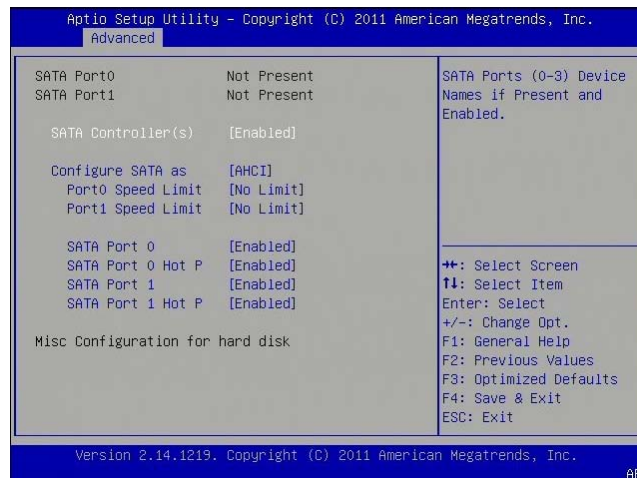

#### SATA Controller(s)

This item allows users to enable or disable the SATA controller(s).

#### Configure SATA As

- IDE This is option configures the Serial ATA drives as Parallel ATA physical storage device.
- RAID This option allows you to create RAID or Intel Matrix Storage configuration on Serial ATA devices.
- AHCI This option configures the Serial ATA drives to use AHCI (Advanced Host Controller Interface). AHCI allows the storage driver to enable the advanced Serial ATA features which will increase storage performance.

### 4.4.7 Intel Fast Flash Standby

This setting allows the user to enable or disable iFFS



#### 4.4.8 USB Configuration

This option allows the user to view and configure the settings of the USB configuration parameters.



#### USB Devices

##### **Legacy USB Support**

This enables Legacy USB Support, the following tables outlines the different modes of this feature:

<u>Option</u>	<u>Description</u>
Auto	This option disables legacy support if no USB devices are connected
Enable	This option will enable Legacy USB support.
Disable	This option will keep USB devices available only for EFI applications.

##### **Legacy USB Support**

Enable the support for legacy USB. Auto option disables legacy support if no USB devices are connected.

##### **EHCI Hand-off**

This is a workaround feature for Operating Systems without EHCI hand-off support. The EHCI ownership must be claimed by EHCI Driver.

<u>Option</u>	<u>Description</u>
Enable	This option enables EHCI hand-off support.
Disable	This option disables EHCI hand-off support.

##### **USB transfer time-out**

Set the time-out value for Control, Bulk, and Interrupt transfers.

##### **Device reset time-out**

Set USB mass storage device Start Unit command time-out value.

**Device power-up delay**

Sets the maximum time the device will take before it properly reports itself to the Host Controller. 'Auto' uses a default value: for a Root port it is 100 ms, for a Hub port the delay is taken from the Hub descriptor.

**4.4.9 SMART Settings**

SMART (Self-Monitoring, Analysis and Reporting Technology) is a monitoring system for computer hard disk drives to detect and report on various indicators of reliability, in the hope of anticipating failures. SMART failure messages might indicate the need to replace the storage device.



**4.4.10 Super IO Configuration**

Set Parameters of Serial Ports. User can Enable/Disable the serial port and Select an optimal settings for the Super IO Device.

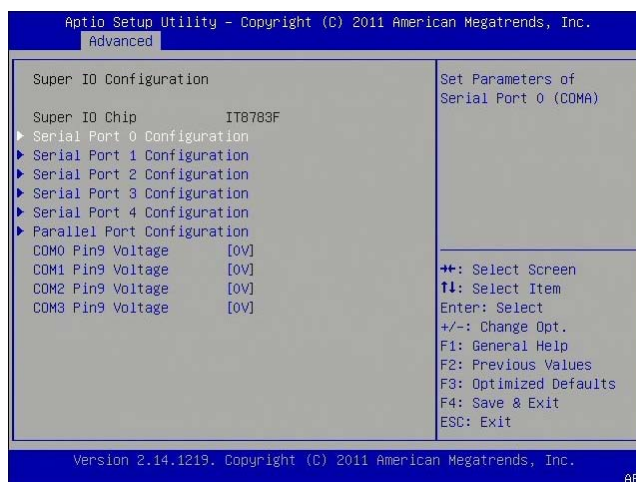

**Serial Port 0-4 Configuration**

Use this item to enable or disable the onboard serial port.

**Parallel Port configuration**

Use this item to enable or disable the onboard parallel port.

#### 4.4.11 Smart Fan Function

Use this feature to control CPU/System Temperature vs. Fan speed. When enabling Smart Fan function, Fan speed is controlled automatically by CPU/System temperature. This function will protect CPU/System from overheat problem and maintain the system temperature at a safe level.

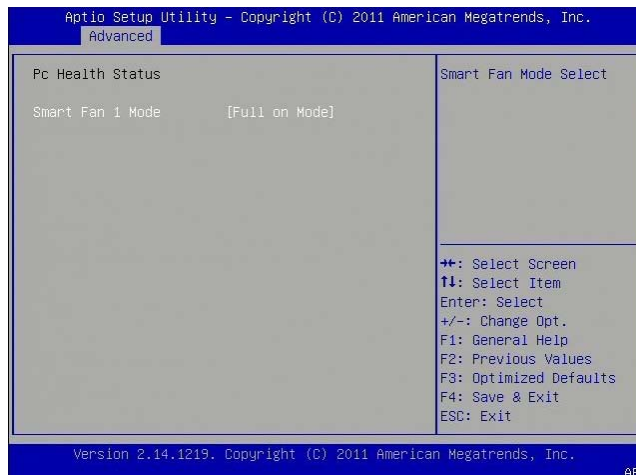

#### 4.4.12 H/W Monitor

This section is used to monitor hardware status such as temperature, fan speed and voltages.

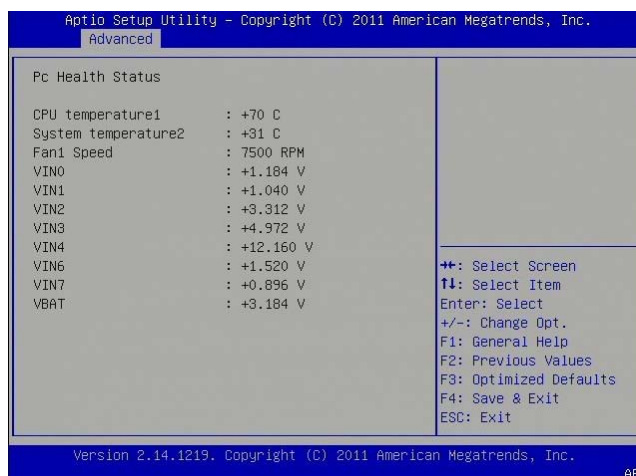

#### CPU Temperature

Detects and displays the current CPU temperature.

#### System Temperature

Detects and displays the current system temperature.

#### Fan1 Speed

Detects and displays the current CPU fan speed.

#### 4.4.13 AOAC Configuration

This item allows users to enable or disabled AOAC function.



#### 4.4.14 Demo Board

This item helps users for CRB test.

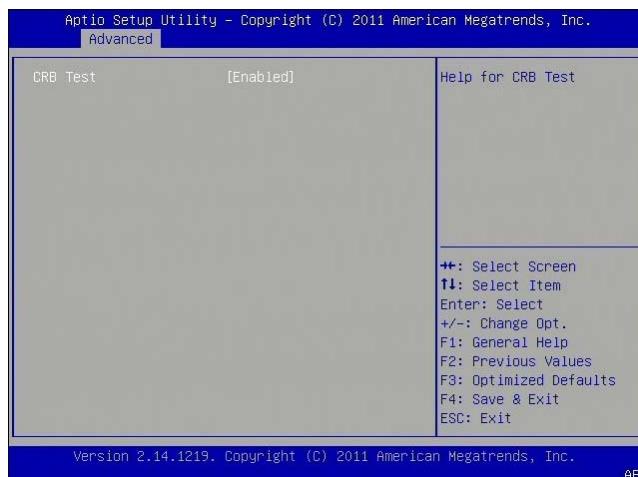

#### 4.4.15 Serial Port Console Redirection

This setting allows the user to enable or disable console redirection

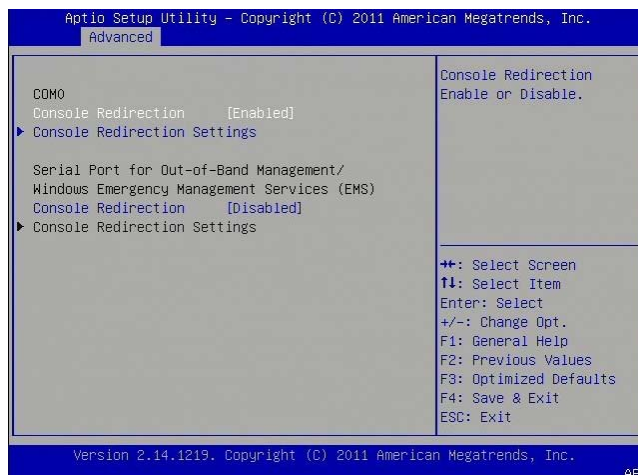

**Console Redirection**

Enabling or disabling of the serial port on the module is specified in the Advanced Configuration menu. Available option are: Disabled, Enabled

**4.4.16 PPM Configuration**

This item allows users to enable or disabled Intel SppedStep.



**EIST**

This item allows users to enable or disabled Intel SpeedStep function.

**CPU C state Report**

This item allows users to enable or disabled CPU C state report to OS.

**4.5 Chipset**

This section allows you to configure and improve your system and allows you to set up some system features according to your preference.

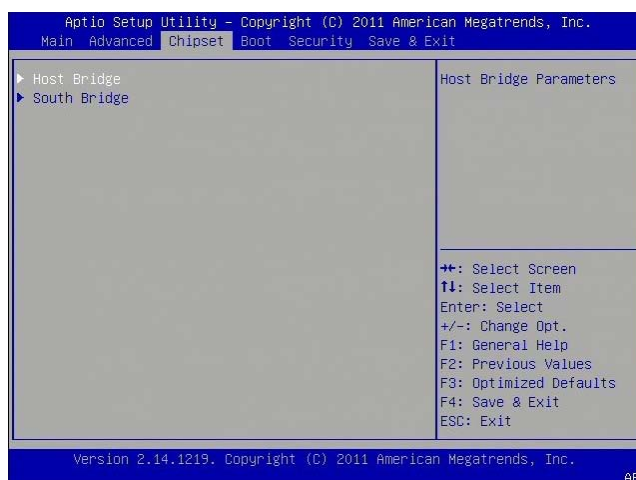

## Host Bridge

This section is used to configure the host bridge features.

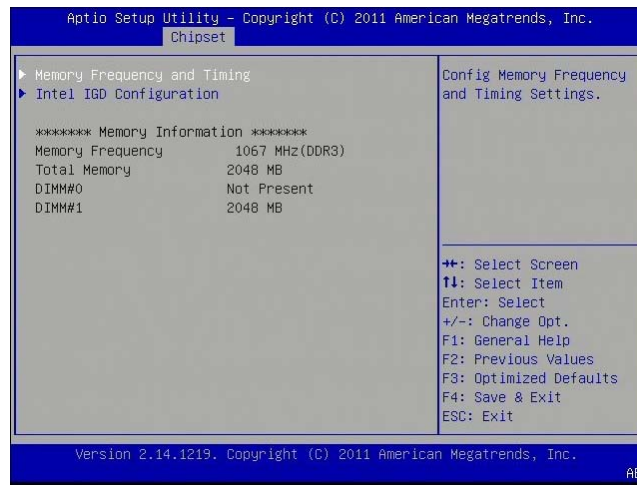

### Memory Frequency and Timing

Configures memory frequency and timing settings

### Intel IGD Configuration

Configures the options for Intel IGD function.

### Memory Information

Detects and displays information on the memory installed in the system.

## South Bridge

This item shows the South Bridge Parameters.

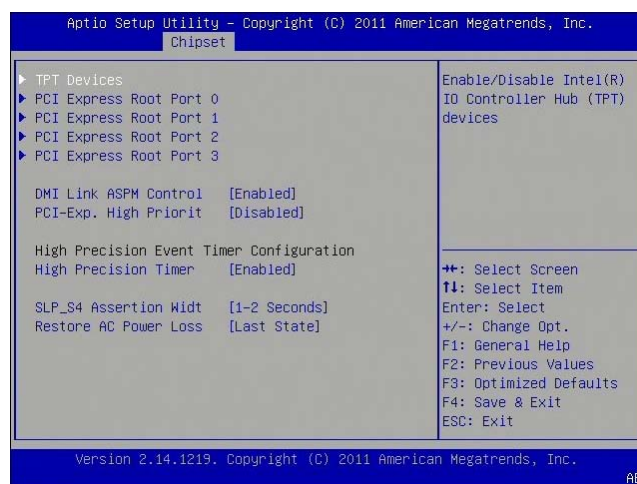

### High Precision Event Timer Configuration

Enable or Disable the High Precision Event Timer.

### SLP\_S4 Assertion Stretch Enable

Select a minimum assertion width of the SLP\_S4# signal.

### Restore AC Power Loss

Options are Power Off, Power On and Last State.

- Power Off      When power returns after an AC power failure, the system's power is off. You must press the power button to power-on the system.
- Power On      When power returns after an AC power failure, the system will automatically power-on.
- Last State    When power returns after an AC power failure, the system will return to the state where you left off before power failure occurs. If the system's power is off when AC power failure occurs, it will remain off when power returns. If the system's power is on when AC power failure occurs, the system will power-on when power returns.

## 4.6 Boot Setting

Use this menu option to configure your boot settings



### Setup Prompt Timeout

Selects the number of seconds to wait for the setup activation key. 65535(0xFFFF) denotes indefinite waiting.

### Bootup NumLock State

This allows you to determine the default state of the numeric keypad. By default, the system boots up with NumLock on wherein the function of the numeric keypad is the number keys. When set to Off, the function of the numeric keypad is the arrow keys.

### Quiet Boot

Set this value to allow the boot up screen options to be modified between POST messages or OEM logo.

### Fast Boot

Enable/Disable faster booting to reduce POST time. [Disabled] performs a complete set of system initialization tasks



**GateA20 Active**

The CPU address bit 20 is controlled by a signal called gateA20. ften gatea20 signal is generated by a peripheral controller (E.g. keyboard Controller) which is a part of the overall system.

**Optional ROM Messages**

Set display mode for Option ROM. Based on this value it displays the messages from Option ROM

**INT19 Trap Response**

Enable: Allows Option ROMs to trap Int 19.

**Boot Option Priorities**

This option shows the priorities of the boot options. User can change the priorities by selecting the particular boot option. The boot option selected in Boot option #1 will be the first priority, followed by second, third and so on.

**4.7 Security**

Use the Security Menu to establish system passwords

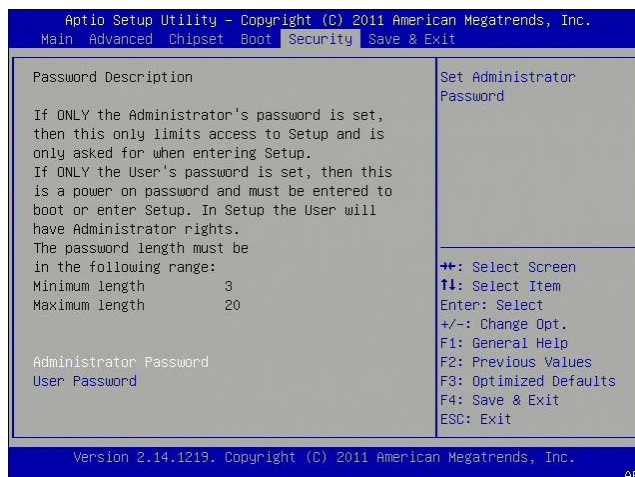

**Administrator Password**

Select this to reconfigure the administrator's password.

**User Password**

Select this to reconfigure the user's password.

## 4.8 Save and exit

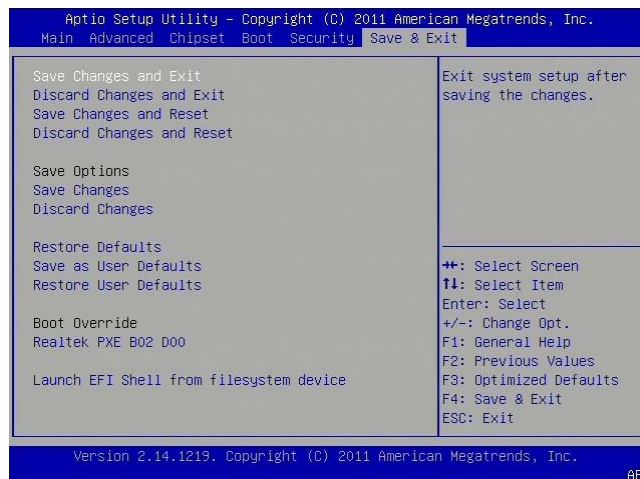

### Save Changes and Exit

Exit system setup after saving the changes.

### Discard Changes and Exit

Exit system setup without saving any changes.

### Save Changes and Reset

Reset the system after saving the changes.

### Discard Changes and Reset

Reset system setup without saving any changes.

### Save Changes

Save Changes done so far to any of the setup options.

### Discard Changes

Discard Changes done so far to any of the setup options.

### Restore Defaults

Restore/Load Defaults values for all the setup options.

### Save as User Defaults

Save the changes done so far as User Defaults.

### Restore User Defaults

Restore the User Defaults to all the setup options.

### Boot Override

Pressing ENTER causes the system to enter the OS.

### Launch EFI Shell from file system device

To launch EFI shell from a file system device, select this field and press <Enter>.