

MB930

(MB930-R, MB930F-R,
MB930GF-R, MB930RF-R)

Socket LGA775

Intel® Q35 Chipset

Industrial Motherboard

USER'S MANUAL

Version 1.0

Acknowledgments

Award is a registered trademark of Award Software International, Inc.

PS/2 is a trademark of International Business Machines Corporation.

Intel are registered trademarks of Intel Corporation.

Microsoft Windows is a registered trademark of Microsoft Corporation.

Winbond is a registered trademark of Winbond Electronics Corporation.

All other product names or trademarks are properties of their respective owners.

Table of Contents

Introduction	1
Checklist.....	1
Product Description.....	1
Specifications	3
Board Dimensions	4
Installations	5
Installing the CPU	6
ATX Power Installation	7
Installing the Memory	8
Setting the Jumpers	9
Connectors on MB930-R	14
Watchdog Timer Configuration	28
BIOS Setup.....	33
Drivers Installation	55
Intel Q35 Chipset Software Installation Utility.....	56
Intel Q35 Chipset Graphics Driver.....	58
Realtek HAD Codec Audio Driver Installation	59
Intel LAN Drivers Installation	60
Appendix	63
A. I/O Port Address Map.....	63
B. Interrupt Request Lines (IRQ).....	64

Ordering Information:

Model	ICH	SATA	Intel LANPHY	PCI-E Gigabit LAN	Remarks
Remarks					
MB930-R	ICH9	4	82562V/ 10/100	N/A	
MB930F-R	ICH9	4	82566DM(1G)	PCI-E GbE (ME88E8053)	
MB930GF-R	ICH9	4	82566DM(1G)	PCI-E GbE (ME88E8053)	PCB thickness: 2.5mm; other specs same as MB930F-R
MB930RF-R (with MOQ)	ICH9R (RAID)	6	82566DM/(1G)	PCI-E GbE (ME88E8053)	

Introduction

Checklist

Your MB930-R/MB930F-R/MB930RF-R motherboard package should include the items listed below:

- The MB930-R/MB930F-R/MB930RF-R motherboard
- This User's manual
- 1 Back I/O shield
- 1 IDE cable
- 1 Floppy cable
- 1 SATA cable
- 1 Serial-Port cable
- 1 CD containing the following:
 - Chipset Drivers
 - Flash Memory Utility

Reminder:

About IDE

The IDE connector on board does not support OS installation in hard drive. A system hard drive connected to this IDE cannot be booted up to OS.

About SATA

When using a legacy operating system, only one SATA controller is available that supports SATA port 0 – 3 (CN8, CN9, CN10, CN11). It is suggested that the legacy operating system is installed using any of these ports.

Product Description

The MB930 LGA 775 motherboard incorporates the Intel Q35 chipset that can utilize a single LGA775 processor of up to 4.0GHz or higher and supports FSB frequency of 800/1066MHz/1333MHz (200MHz(800MT/s) and 266MHz(1066MT/s), 333MHz(1333MT/s) HCLK respectively.

The Q35 chipset is designed for use with the Core.2 processor family, including a faster 1333 MHz system bus. The integrated GMCH component provides the CPU interface, DDR2 interface, Hub Interface and PCI Express graphics interface.

Four DDR2 memory sockets support DDR2 667/800 SDRAM DIMM modules of up to 8GB in capacity.

The board is designed with one Intel 82566DM PCI Express Gigabit PHY (MB930RF-R/MB930F-R) or 82562V 10/100 PHY (MB930-R only) LAN controllers. Serial-II ATA connectors offer 3Gb/s data throughput speed - faster than the most advanced parallel ATA.

Expansion includes four PCI slots, one PCI Express x1 and one PCI Express x16 and one ISA slot. Other advanced features include ten USB 2.0 ports, IrDA interface, digital I/O, four serial ports, watchdog timer and audio function. Dimensions of the board are 12" by 9.5" in an ATX form factor.

Remarks:

MB930-R/MB930F-R/MB930RF-R supports Intel Supports the Intel Core 2 Duo and Intel Core 2 Quad processors, and Intel Celeron 400(Conroe-L) Sequence processor.

MB930RF-R supports six Serial ATA connectors (with RAID function). MB930-R / MB930F-R / MB930GF-R supports four Serial ATA connectors only. MB930GF-R has the same specifications as MB930F-R, except that its PCB thickness is 2.4mm).

The IDE connector on board does not support OS installation in hard drive. A system hard drive connected to this IDE cannot be booted up to OS.

Specifications

Product Name	MB930-R/MB930F-R/MB930RF-R
CPU Support	Socket LGA775, Supports the Intel Core 2 Duo and Intel Core2 Quad processors, and Intel Celeron 400 (Conroe-L) Sequence processor.
CPU Voltage	0.5V~1.6V (VRD 11.0)
System Speed	Up to 3.8GHz+
CPU FSB	800MHz/1066MHz /1333MHz
Green /APM	APM1.2
CPU Socket	LGA 775
Chipset	Intel® Bearlake Chipset Q35+ICH9 for MB930-R and MB930F-R Q35+ICH9R for MB930RF-R only
BIOS	Award BIOS; supports ACPI
VGA	Q35 built-in, supports CRT
LAN1	LAN1: Dual footprint support option *Intel 82566DM PCI Express Gigabit for MB930F-R and MB930RF-R *Intel 82562V PHY 10/100 for MB930-R only
LAN2	Marvell PCI Express Gigabit for MB930F-R and MB930RF-R
Audio	ICH9/ICH9R Built-in audio + HDA codec
Memory type	Support Dual Channel DDR2 DIMM Module x 4, 667/800MHz (Without ECC function), Max. 8GB
LPC I/O	W83627EHG: IrDA x1, Parallel x1, COM1 (RS232), COM2 (RS232/422/485), FDCx1, Hardware monitoring
RTC/CMOS	Built in ICH9/ICH9R
Battery	Lithium battery
Keyboard Controller	Built-in Winbond 83627EHG
PATA	JMicro JMB368 PCI-E to PATA controller for one PATA channel support One PATA : IDE connectorx1 +Compact Flash socket Type II x1 IDE1(40pin/2.5mm)supports Ultra DMA 33/66/100 compact Flash (use IDE or CF at a time only)
SATA2 connector	MB930-R,MB930F-R supports 4x SATA2 (300MB/s) MB930RF-R supports 6x SATA2 with RAID function
D-type connectors	PS/2 mouse, PS/2 KB, VGA (CRT), RJ-45, Sound, USB x 4
Power Connector	ATX 24-pin
Expansion Slots	1 x (PCI Express x16) slot, 1 x (PCI Express x1) slot 4 x PCI slots, 1 x ISA slots (slave only), cannot support ISA master and DMA access function
PCI to ISA Bridge	Winbond W83628F with W83629D
Secondary Super I/O	Fintek F81216, supports COM3, COM4 (RS232)
USB	ICH9 built in USB Version 2.0, support 8 ports (D-type connector x 4 port & pin header x 4 port)
Digital I/O	4 In, 4 Out
Watchdog Timer	Supports 256 segments (0,1,2...255. Sec/min)
System Voltages	+5V, +12V, -12V, 5VSB, -5V, 3.3V
Board Size	12" x 9.5" (ATX form factor)
Other Features	IrDA interface, Modem Wakeup,
Dimensions	305mm x 244mm (12" x 9.6")

Board Dimensions

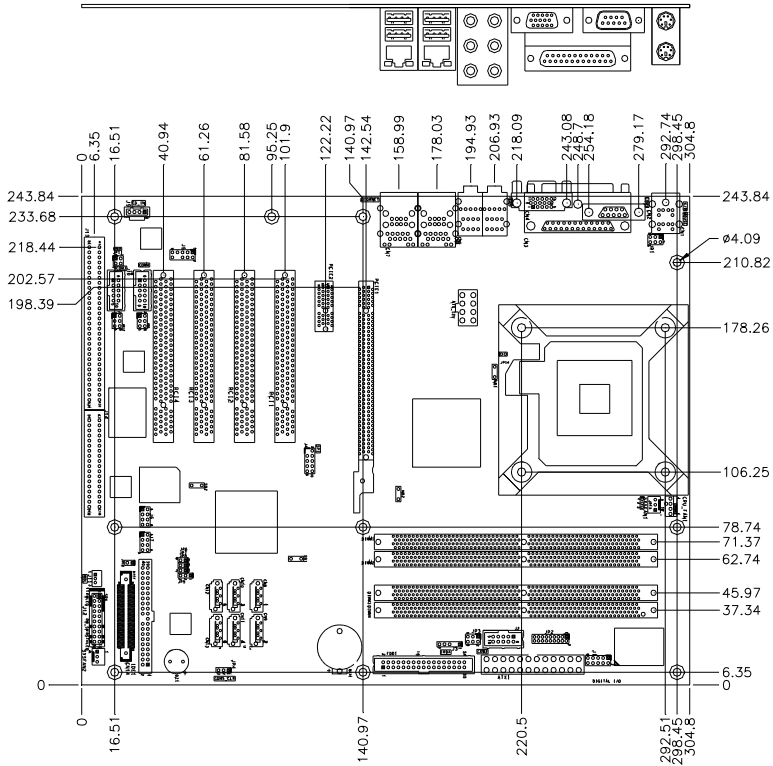

Installations

This section provides information on how to use the jumpers and connectors on the MB930-R/MB930F-R/MB930RF-R in order to set up a workable system. The topics covered are:

Installing the CPU	6
ATX Power Installation	7
Installing the Memory	8
Setting the Jumpers	9
Connectors on MB930-R	14
Watchdog Timer Configuration	28

Reminder:

The IDE connector on board does not support OS installation in hard drive. A system hard drive connected to this IDE cannot be booted up to OS.

Installing the CPU

The MB930-R/MB930F-R/MB930RF-R motherboard support an LGA 775 processor socket for Intel Core 2 Duo and Intel Core2 Quad processors, and Intel Celeron 400(Conroe-L) Sequence processor.

The LGA 775 processor socket comes with a lever to secure the processor. Refer to the pictures below, from left to right, on how to place the processor into the CPU socket. ***Please note that the cover of the LGA775 socket must always be installed during transport to avoid damage to the socket.***

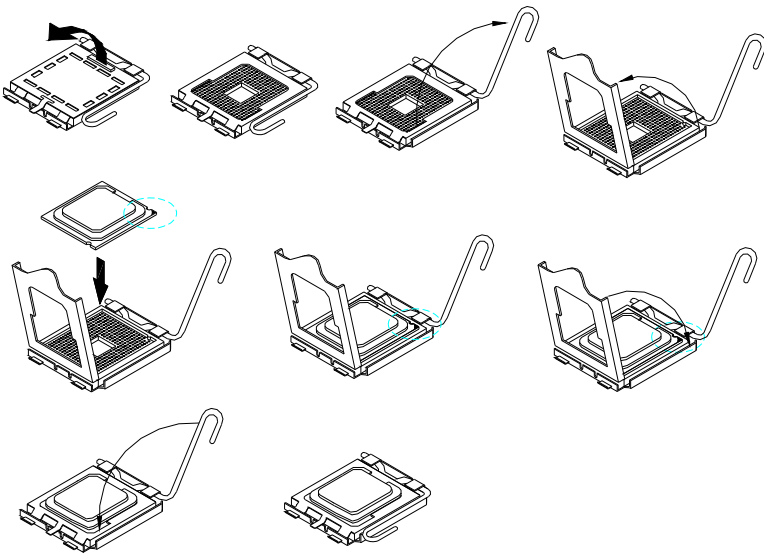

ATX Power Installation

The system power is provided to the motherboard with the ATX1 and ATX_12V power connectors. ATX1 is a 24-pin power connector and ATX_12V is a 8-pin 12V power connector.

The 24-pin power connector can to be connected to a standard 20-pin ATX power connector in a standard ATX power supply (Min. 400watt).

Note: The power supply 5VSB voltage must be at least 2A.

Installing the Memory

The MB930-R/MB930F-R/MB930RF-R motherboard support four DDR2 memory sockets for a maximum total memory of 8GB in DDR memory type. It supports DDR2 667/800.

Basically, the system memory interface has the following features:

- Supports two 64-bit wide DDR data channels
- Available bandwidth up to 6.4GB/s (DDR2 800) for single-channel mode and 12.8GB/s (DDR2 800) in dual-channel mode.
- Supports 256Mb, 512Mb, 1Gb DDR2 technologies.
- Supports only x8, x16, DDR2 devices with four banks
- Supports only unbuffered DIMMs
- Supports opportunistic refresh
- Up to 32 simultaneously open pages (four per row, four rows maximum)

Dual Channel Memory Configuration

If you want to operate the Dual Channel Technology, please note the following explanations due to the limitation of Intel chipset specifications.

1. Dual Channel mode will not be enabled if only one DDR II memory module is installed.
2. To enable Dual Channel mode with two or four memory modules (it is recommended to use memory modules of identical brand, size, chips, and speed), you must install them into DIMM sockets of the same color. The following is a Dual Channel Memory configuration table: (DS: Double Side, SS: Single Side)

	DDR11	DDR12	DDR13	DDR14
2MemoryModules	DS/SS	X	DS/SS	X
	X	DS/SS	X	DS/SS
4MemoryModules	DS/SS	DS/SS	DS/SS	DS/SS

Setting the Jumpers

Jumpers are used on MB930-R/MB930F-R/MB930RF-R to select various settings and features according to your needs and applications. Contact your supplier if you have doubts about the best configuration for your needs. The following lists the connectors on MB930-R/MB930F-R/MB930RF-R and their respective functions.

JP1: COM1 RS232 +5V/+12V Power Setting	11
JP2: RS232/422/485 (COM2) Selection.....	11
JP3: COM2 RS232 +5V/+12V Power Setting	11
JP4: Clear CMOS Contents	12
JP5: Configure and Recovery (Factory use only).....	12
JP8: ME (Management Engine) – Disabled / pin closed.....	12
JP9: COM4 RS232 +5V/+12V Power Setting	12
JP10: Compact Flash Socket Master/Slave Setting	13
JP12: COM3 RS232 +5V/+12V Power Setting	13

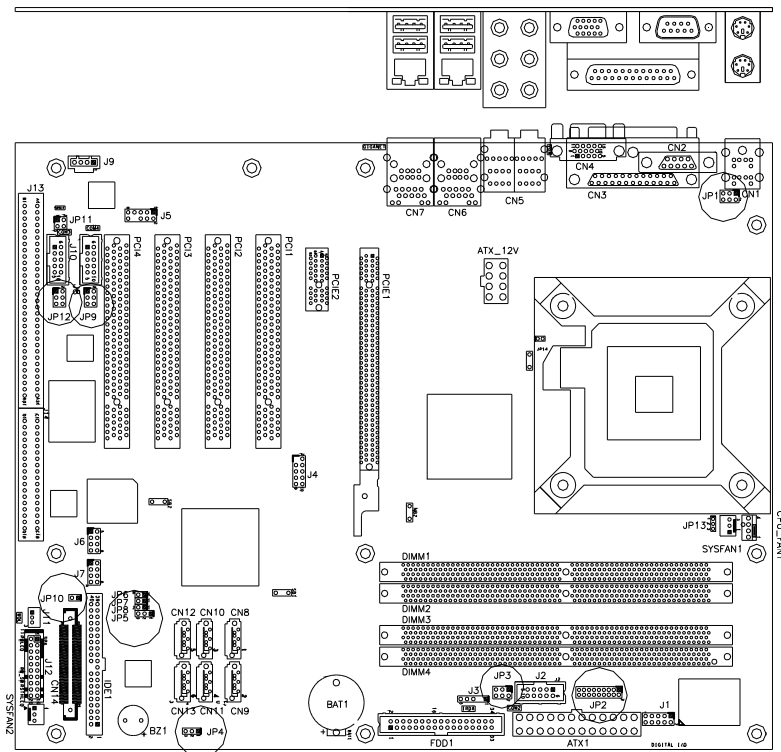

Jumper Locations Page

JP1: COM1 RS232 +5V/+12V Power Setting..... 11

JP2: RS232/422/485 (COM2) Selection..... 11

JP3: COM2 RS232 +5V/+12V Power Setting..... 11

JP4: Clear CMOS Contents 12

JP5: Configure and Recovery (Factory use only)..... 12

JP8: ME (Management Engine) – Disabled / pin closed 12

JP9: COM4 RS232 +5V/+12V Power Setting..... 12

JP10: Compact Flash Socket Master/Slave Setting 13

JP12: COM3 RS232 +5V/+12V Power Setting..... 13

JP1: COM1 RS232 +5V/+12V Power Setting

JP1	Setting	Function
	Pin 1-2 Short/Closed	+12V
	Pin 3-4 Short/Closed	Normal
	Pin 5-6 Short/Closed	+5V

JP2: RS232/422/485 (COM2) Selection

COM1 is fixed for RS-232 use only.

JP2, COM2 is selectable for RS232, RS-422 and RS-485.

The following table describes the jumper settings for COM2 selection.

COM2 Function	RS-232	RS-422	RS-485	
	Short: 1-2	Short: 3-4	Short: 5-6	
	Jumper Setting (pin closed)	9-11	7-9	7-9
		10-12	8-10	8-10
		15-17	13-15	13-15
		16-18	14-16	14-16



Note: Factory is default RS-232

JP3: COM2 RS232 +5V/+12V Power Setting



JP3	Setting	Function
	Pin 1-2 Short/Closed	+12V
	Pin 3-4 Short/Closed	Normal
	Pin 5-6 Short/Closed	+5V

JP4: Clear CMOS Contents

Use JP4, a 3-pin header, to clear the CMOS contents. *Note that the ATX-power connector should be disconnected from the motherboard before clearing CMOS.*

JP4	Setting	Function
	Pin 1-2 Short/Closed	Normal
	Pin 2-3 Short/Closed	Clear CMOS

JP5: Configure and Recovery (Factory use only)

JP5	Setting	Function
	Pin 1-2 Short/Closed	Normal (default)
	Pin 2-3 Short/Closed	Configure
	Open	Recovery



JP8: ME (Management Engine) – Disabled / pin closed

The factory default setting of the 2-pin JP8 jumper is closed. This means the management engine function is disabled.

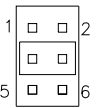
JP9: COM4 RS232 +5V/+12V Power Setting

JP9	Setting	Function
	Pin 1-2 Short/Closed	+12V
	Pin 3-4 Short/Closed	Normal
	Pin 5-6 Short/Closed	+5V

JP10: Compact Flash Socket Master/Slave Setting

JP10	Compact Flash
 <p>Short</p>	Master
 <p>Open</p>	Slave

JP12: COM3 RS232 +5V/+12V Power Setting

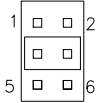
JP12	Setting	Function
	Pin 1-2 Short/Closed	+12V
	Pin 3-4 Short/Closed	Normal
	Pin 5-6 Short/Closed	+5V

Connectors on MB930-R

The connectors on MB930-R/MB930F-R/MB930RF-R allow you to connect external devices such as keyboard, floppy disk drives, hard disk drives, printers, etc.

ATX1: 24-pin ATX Power Connector.....	16
ATX_12V1: ATX 12V Power Connector	16
DIMM1,2: Channel A DDR2 Socket	17
DIMM3,4 Channel B DDR2 Socket.....	17
CN1: PS/2 Keyboard and PS/2 Mouse Connectors	17
CN2: Serial Ports(COM1)	17
CN3: Parallel Port Connector	18
CN4: VGA CRT Connector.....	18
CN5: HD Audio Connector	19
CN6: 10/100 RJ-45&USB 0/1 Connector (MB930-R).....	19
CN6: GbE RJ-45 &USB 0/1 (MB930F-R/MB930RF-R).....	19
CN7: USB2/3 Connector (MB930-R)	19
CN7: Marvell GbE RJ-45&USB2/3 (MB930F-R/MB930RF-R)	20
CN8, CN9, CN10, CN11, CN12,CN13 SATA Connector	20
CN14: Compact Flash TYPE II Socket	20
J1: Digital I/O Connector (4 in, 4 out).....	20
J2: COM2 Serial Port.....	21
J3: IrDA Connector.....	21
J4: SPI Debug Tools Port (Factory use only)	21
J5: Audio Front Header	21
J6: USB6/USB7 Connector	22
J7: USB4/USB5 Connector	22
J8, J10: COM3, COM4 Serial Ports(RS232)	22
J9: CD-In Audio Connector.....	22
J11: Wake On LAN Connector.....	23
J12: System Function Connector	23
J13: ISA Slot.....	25
JP11: SPDIFI/ SPDIFO Connector (Reserved)	25
IDE1: Primary IDE Connectors	25
CPU_FAN1: CPU Fan Power Connector.....	26
SYS_FAN1: system Fan1 Power Connector	26
SYS_FAN2: SYSTEM Fan2 Power Connector	26
FDD1: Floppy Drive Connector	26
PCIE_1: x16 PCI Express Slot	27
PCIE_2: x1 PCI Express Slots.....	27
PCI1, PCI2, PCI3, PCI4: PCI Slots	27

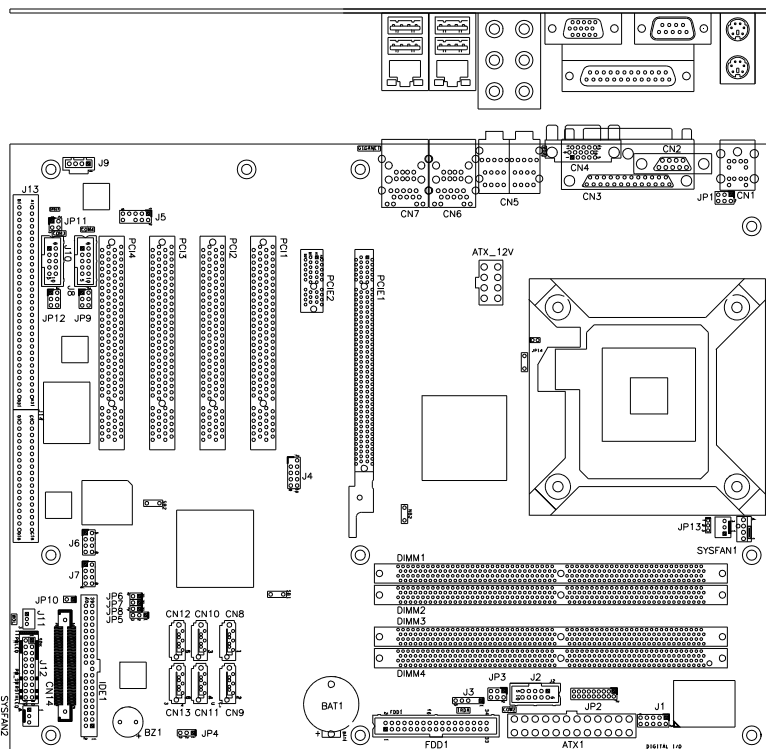

Connectors on MB930-R/MB930-RF

ATX1: 24-pin ATX Power Connector	J3: IrDA Connector
ATX_12V1: ATX 12V Power Connector	J4: SPI Debug Tools Port (Factory use only)
DIMM1,2: Channel A DDR2 Socket	J5: Audio Front Header
DIMM3,4 Channel B DDR2 Socket	J6: USB6/USB7 Connector
CN1: PS/2 Keyboard and PS/2 Mouse	J7: USB4/USB5 Connector
CN2: Serial Ports(COM1)	J8, J10: COM3, COM4 Serial Ports(RS232)
CN3: Parallel Port Connector	J9: CD-In Audio Connector
CN4: VGA CRT Connector	J11: Wake On LAN Connector
CN5: HD Audio Connector	J12: System Function Connector
CN6: 10/100 RJ-45&USB 0/1 (MB930-R)	J13: ISA Slot
CN6: GbE RJ-45 &USB 0/1 (MB930F-R/MB930RF-R)	JP11: SPDIFI/ SPDIFO Connector (Reserved)
CN7: USB2/3 Connector (MB930-R)	IDE1: Primary IDE Connectors
CN7: GbE RJ-45&USB2/3 (MB930F-R/MB930RF-R)	CPU_FAN1: CPU Fan Power Connector
CN8, CN9, CN10, CN11, CN12,CN13 SATA	SYS_FAN1: system Fan1 Power Connector
CN14: Compact Flash TYPE II Socket	SYS_FAN2: SYSTEM Fan2 Power Connector
J1: Digital I/O Connector (4 in, 4 out)	FDD1: Floppy Drive Connector
J2: COM2 Serial Port	PCIE_1: x16 PCI Express Slot
LED1: DRAM POWER LED Indicator	PCIE_2: x1 PCI Express Slots
	PCI1, PCI2, PCI3, PCI4: PCI Slots

MB930-R Edge Connectors

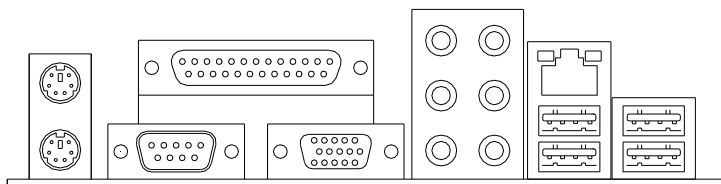

MB930F-R/MB930RF-R/MB930GF-R Edge Connectors

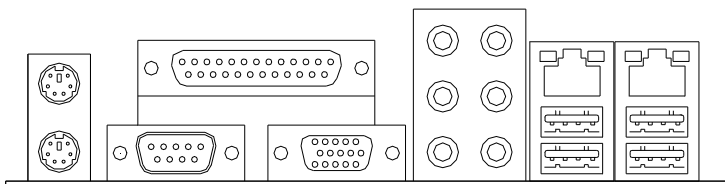

ATX1: 24-pin ATX Power Connector

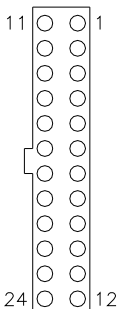

Signal Name	Pin #	Pin #	Signal Name
3.3V	13	1	3.3V
-12V	14	2	3.3V
Ground	15	3	Ground
PS-ON	16	4	+5V
Ground	17	5	Ground
Ground	18	6	+5V
Ground	19	7	Ground
-5V	20	8	Power good
+5V	21	9	5VSB
+5V	22	10	+12V
+5V	23	11	+12V
Ground	24	12	+3.3V

ATX_12V1: ATX 12V Power Connector

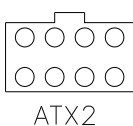

Signal Name	Pin #	Pin #	Signal Name
+12V	5	1	Ground
+12V	6	2	Ground
+12V	7	3	Ground
+12V	8	4	Ground

DIMM1, 2: Channel A DDR2 Socket

DIMM1, 2 are the first-channel DDR2 sockets.

DIMM3, 4 Channel B DDR2 Socket

DIMM3, 4 are the second-channel DDR2 sockets.

CN1: PS/2 Keyboard and PS/2 Mouse Connectors

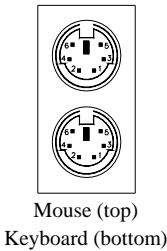

Keyboard Signal	Pin #	Mouse Signal
Keyboard data	1	Mouse data
N.C.	2	N.C.
GND	3	GND
5V	4	5V
Keyboard clock	5	Mouse clock
N.C.	6	N.C.

CN2: Serial Ports(COM1)

CN2 (COM1) is a DB-9 connector, while J2, J8 and J10 are COM pin-header connectors.

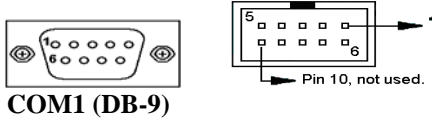

Signal Name	Pin #	Pin #	Signal Name
DCD, Data carrier detect	1	6	DSR, Data set ready
RXD, Receive data	2	7	RTS, Request to send
TXD, Transmit data	3	8	CTS, Clear to send
DTR, Data terminal ready	4	9	RI, Ring indicator
GND, ground	5	10	Not Used

CN3: Parallel Port Connector

CN3 is a DB-25 external connector situated on top of the VGA and serial ports.

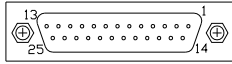

CN3 Parallel Port

Signal Name	Pin #	Pin #	Signal Name
Line printer strobe	1	14	AutoFeed
PD0, parallel data 0	2	15	Error
PD1, parallel data 1	3	16	Initialize
PD2, parallel data 2	4	17	Select
PD3, parallel data 3	5	18	Ground
PD4, parallel data 4	6	19	Ground
PD5, parallel data 5	7	20	Ground
PD6, parallel data 6	8	21	Ground
PD7, parallel data 7	9	22	Ground
ACK, acknowledge	10	23	Ground
Busy	11	24	Ground
Paper empty	12	25	Ground
Select	13	N/A	N/A

CN4: VGA CRT Connector

CN4 is a DB-15 VGA connector located beside the COM1 port. The following table shows the pin-out assignments of this connector.

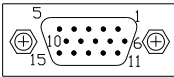

Signal Name	Pin #	Pin #	Signal Name
Red	1	2	Green
Blue	3	4	N.C.
GND	5	6	GND
GND	7	8	GND
VCC	9	10	GND
N.C.	11	12	DDCDATA
HSYNC	13	14	VSYNC
DDCCLK	15		

CN5: HD Audio Connector

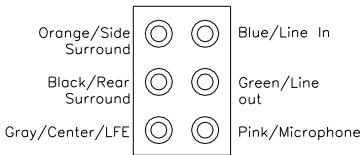

CN6: 10/100 RJ-45&USB 0/1 Connector (MB930-R)

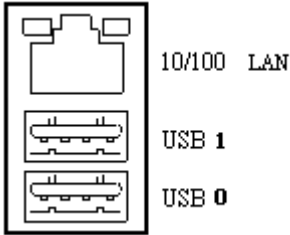

CN6: GbE RJ-45 &USB 0/1 Connector (MB930F-R/MB930GF-R/MB930RF-R)

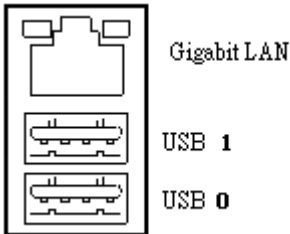

CN7: USB2/3 Connector (MB930-R)

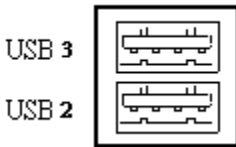

CN7: Marvell GbE RJ-45&USB2/3 Connector (MB930F-R/ MB930GF-R /MB930RF-R)

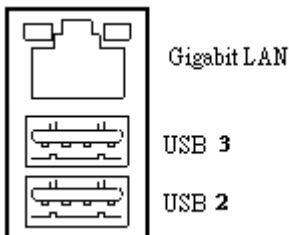

CN8, CN9, CN10, CN11, CN12,CN13 SATA Connector

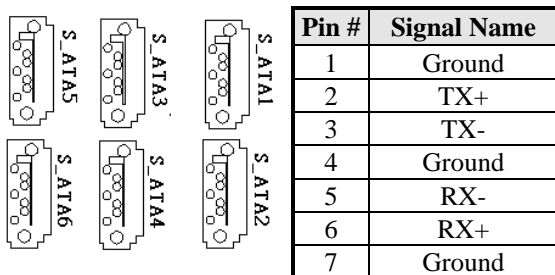

Note:

*MB930-R, MB930F-R supports 4x SATA II (300MB/s) ,S_ATA1,2,5,6 .
 MB930RF-R supports 6x SATA II with RAID function,S_ATA1,2,3,4,5,6.*

CN14: Compact Flash Type II Socket

Note: The CompactFlash interface cannot be used simultaneously with the IDE interface.

J1: Digital I/O Connector (4 in, 4 out)

This 10-pin digital I/O connector supports TTL levels and is used to control external devices requiring ON/OFF circuitry.

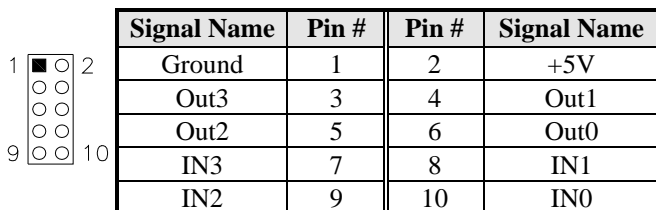

J2: COM2 Serial Port

COM2 is jumper selectable for RS-232, RS-422 and RS-485.

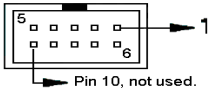

Please refer to JP2: RS232/422/485 (COM2) Selection

Pin #	Signal Name		
	RS-232	R2-422	RS-485
1	DCD	TX-	DATA-
2	RX	TX+	DATA+
3	TX	RX+	NC
4	DTR	RX-	NC
5	Ground	Ground	Ground
6	DSR	RTS-	NC
7	RTS	RTS+	NC
8	CTS	CTS+	NC
9	RI	CTS-	NC
10	NC	NC	NC

J3: IrDA Connector

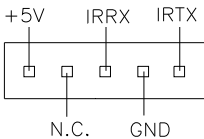

Pin #	Signal Name
1	+5V
2	No connect
3	Ir RX
4	Ground
5	Ir TX

J4: SPI Debug Tools Port (Factory use only)

J5: Audio Front Header

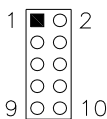

Signal Name	Pin #	Pin #	Signal Name
MIC2_L	1	2	Ground
MIC2_R	3	4	Presence#
Line2_R	5	6	MIC2_ID
Sense	7	8	NC
Line2_L	9	10	Line2_ID

J6: USB6/USB7 Connector

The following table shows the pin outs of the USB pin header.

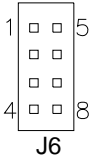

Signal Name	Pin	Pin	Signal Name
Vcc	1	5	Ground
USB0-	2	6	USB1+
USB0+	3	7	USB1-
Ground	4	8	Vcc

J7: USB4/USB5 Connector

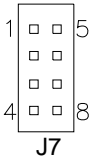

Signal Name	Pin	Pin	Signal Name
Vcc	1	5	Ground
USB0-	2	6	USB1+
USB0+	3	7	USB1-
Ground	4	8	Vcc

J8, J10: COM3, COM4 Serial Ports(RS232)

J8 and J10 are COM pin-header connectors.

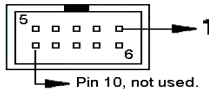

Signal Name	Pin #	Pin #	Signal Name
DCD, Data carrier detect	1	6	DSR, Data set ready
RXD, Receive data	2	7	RTS, Request to send
TXD, Transmit data	3	8	CTS, Clear to send
DTR, Data terminal ready	4	9	RI, Ring indicator
GND, ground	5	10	Not Used

J9: CD-In Audio Connector



Pin #	Signal Name
1	CD Audio R
2	Ground
3	Ground
4	CD Audio L

J11: Wake On LAN Connector

J11 is a 3-pin header for the Wake On LAN function on the motherboard. The following table shows the pin out assignments of this connector. Wake On LAN will function properly only with an ATX power supply with 5VSB that has 1A.

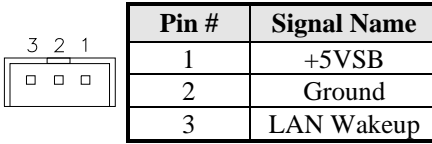

J12: System Function Connector

J12 provides connectors for system indicators that provide light indication of the computer activities and switches to change the computer status.

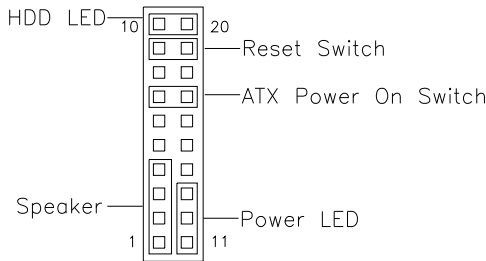

Speaker: Pins 1 - 4

This connector provides an interface to a speaker for audio tone generation. An 8-ohm speaker is recommended.

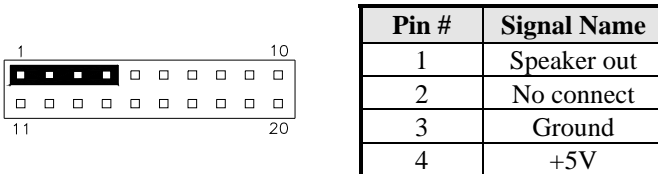

Power LED: Pins 11 - 13

The power LED indicates the status of the main power switch.

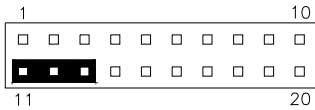

Pin #	Signal Name
11	Power LED
12	No connect
13	Ground

ATX Power ON Switch: Pins 7 and 17

This 2-pin connector is an “ATX Power Supply On/Off Switch” on the system that connects to the power switch on the case. When pressed, the power switch will force the system to power on. When pressed again, it will force the system to power off.

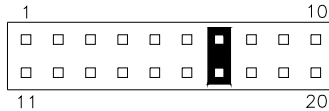

Reset Switch: Pins 9 and 19

The reset switch allows the user to reset the system without turning the main power switch off and then on again. Orientation is not required when making a connection to this header.

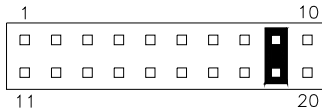

Hard Disk Drive LED Connector: Pins 10 and 20

This connector connects to the hard drive activity LED on control panel. This LED will flash when the HDD is being accessed.

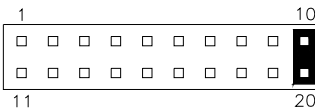

Pin #	Signal Name
10	HDD Active
20	5V

J13: ISA Slot

ISA slot does not support ISA master & DMA access function, but only ISA peripheral cards.

JP11: SPDIFI/ SPDIFO Connector (Reserved)

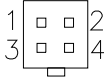

Pin #	Signal Name
1	SPDIF/I
2	Ground
3	SPDIF/O
4	Ground

IDE1: Primary IDE Connectors

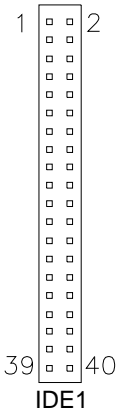

Signal Name	Pin #	Pin #	Signal Name
Reset IDE	1	2	Ground
Host data 7	3	4	Host data 8
Host data 6	5	6	Host data 9
Host data 5	7	8	Host data 10
Host data 4	9	10	Host data 11
Host data 3	11	12	Host data 12
Host data 2	13	14	Host data 13
Host data 1	15	16	Host data 14
Host data 0	17	18	Host data 15
Ground	19	20	Protect pin
DRQ0	21	22	Ground
Host IOW	23	24	Ground
Host IOR	25	26	Ground
IOCHRDY	27	28	Host ALE
DACK0	29	30	Ground
IRQ14	31	32	No connect
Address 1	33	34	No connect
Address 0	35	36	Address 2
Chip select 0	37	38	Chip select 1
Activity	39	40	Ground

Note: The CompactFlash interface cannot be used simultaneously with the IDE interface.

The IDE connector on board does not support OS installation in hard drive. A system hard drive connected to this IDE cannot be booted up to OS.

CPU_FAN1: CPU Fan Power Connector

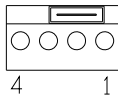

Pin #	Signal Name
1	Ground
2	+12V
3	Rotation detection
4	Control

SYS_FAN1: system Fan1 Power Connector

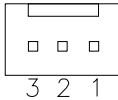

Pin #	Signal Name
1	Ground
2	+12V
3	Rotation detection

SYS_FAN2: SYSTEM Fan2 Power Connector

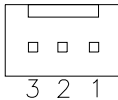

Pin #	Signal Name
1	Ground
2	+12V
3	Rotation detection

FDD1: Floppy Drive Connector

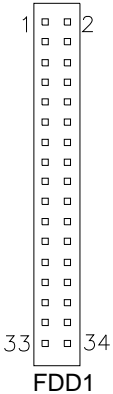

Signal Name	Pin #	Pin #	Signal Name
Ground	1	2	RM/LC
Ground	3	4	No connect
Ground	5	6	No connect
Ground	7	8	Index
Ground	9	10	Motor enable 0
Ground	11	12	Drive select 1
Ground	13	14	Drive select 0
Ground	15	16	Motor enable 1
Ground	17	18	Direction
Ground	19	20	Step
Ground	21	22	Write data
Ground	23	24	Write gate
Ground	25	26	Track 00
Ground	27	28	Write protect
Ground	29	30	Read data
Ground	31	32	Side 1 select
Ground	33	34	Diskette change

PCIE_1: x16 PCI Express Slot

PCIE_2: x1 PCI Express Slots

PCI1, PCI2, PCI3, PCI4: PCI Slots

Watchdog Timer Configuration

The WDT is used to generate a variety of output signals after a user programmable count. The WDT is suitable for use in the prevention of system lock-up, such as when software becomes trapped in a deadlock. Under these sorts of circumstances, the timer will count to zero and the selected outputs will be driven. Under normal circumstance, the user will restart the WDT at regular intervals before the timer counts to zero.

SAMPLE CODE:

```
//=====
//
// THIS CODE AND INFORMATION IS PROVIDED "AS IS" WITHOUT WARRANTY OF ANY
// KIND, EITHER EXPRESSED OR IMPLIED, INCLUDING BUT NOT LIMITED TO THE
// IMPLIED WARRANTIES OF MERCHANTABILITY AND/OR FITNESS FOR A PARTICULAR
// PURPOSE.
//
//=====
=====
#include <stdio.h>
#include <stdlib.h>
#include "W627EHF.H"
//=====
=====
int main (int argc, char *argv[]);
void copyright(void);
void EnableWDT(int);
void DisableWDT(void);
//=====
=====
int main (int argc, char *argv[])
{
    unsigned char bBuf;
    unsigned char bTime;
    char **endptr;

    copyright();

    if (argc != 2)
    {
        printf(" Parameter incorrect!!\n");
        return 1;
    }

    if (Init_W627EHF() == 0)
    {
        printf(" Winbond 83627HF is not detected, program abort.\n");
        return 1;
    }
    bTime = strtol (argv[1], endptr, 10);
```



```

    printf("System will reset after %d seconds\n", bTime);

    EnableWDT(bTime);

    return 0;
}
//=====
void copyright(void)
{
    printf("\n===== Winbond 83627EHF Watch Timer Tester (AUTO DETECT)
===== \n\
        " Usage : W627E_WD reset_time\n\
        " Ex : W627E_WD 3 => reset system after 3 second\n\
        " W627E_WD 0 => disable watch dog timer\n");
}
//=====
void EnableWDT(int interval)
{
    unsigned char bBuf;

    bBuf = Get_W627EHF_Reg( 0x2D);
    bBuf &= (!0x01);
    Set_W627EHF_Reg( 0x2D, bBuf); //Enable WDT0

    Set_W627EHF_LD( 0x08); //switch to logic device 8
    Set_W627EHF_Reg( 0x30, 0x01); //enable timer

    bBuf = Get_W627EHF_Reg( 0xF5);
    bBuf &= (!0x08);
    Set_W627EHF_Reg( 0xF5, bBuf); //count mode is second

    Set_W627EHF_Reg( 0xF6, interval); //set timer
}
//=====
void DisableWDT(void)
{
    Set_W627EHF_LD(0x08); //switch to logic device 8
    Set_W627EHF_Reg(0xF6, 0x00); //clear watchdog timer
    Set_W627EHF_Reg(0x30, 0x00); //watchdog disabled
}
//=====

```

INSTALLATIONS

```
//=====
//
// THIS CODE AND INFORMATION IS PROVIDED "AS IS" WITHOUT WARRANTY OF ANY
// KIND, EITHER EXPRESSED OR IMPLIED, INCLUDING BUT NOT LIMITED TO THE
// IMPLIED WARRANTIES OF MERCHANTABILITY AND/OR FITNESS FOR A PARTICULAR
// PURPOSE.
//
//=====
====
#include "W627EHF.H"
#include <dos.h>
//=====
====
unsigned int W627EHF_BASE;
void Unlock_W627EHF (void);
void Lock_W627EHF (void);
//=====
unsigned int Init_W627EHF(void)
{
    unsigned int result;
    unsigned char ucDid;

    W627EHF_BASE = 0x2E;
    result = W627EHF_BASE;

    ucDid = Get_W627EHF_Reg(0x20);
    if (ucDid == 0x88)
    {    goto Init_Finish;  }

    W627EHF_BASE = 0x4E;
    result = W627EHF_BASE;
    ucDid = Get_W627EHF_Reg(0x20);
    if (ucDid == 0x88)
    {    goto Init_Finish;  }

    W627EHF_BASE = 0x00;
    result = W627EHF_BASE;

Init_Finish:
    return (result);
}
//=====
void Unlock_W627EHF (void)
{
    outportb(W627EHF_INDEX_PORT, W627EHF_UNLOCK);
    outportb(W627EHF_INDEX_PORT, W627EHF_UNLOCK);
}
//=====
====
void Lock_W627EHF (void)
{
    outportb(W627EHF_INDEX_PORT, W627EHF_LOCK);
}
//=====
void Set_W627EHF_LD( unsigned char LD)
{
    Unlock_W627EHF();
    outportb(W627EHF_INDEX_PORT, W627EHF_REG_LD);
    outportb(W627EHF_DATA_PORT, LD);
}
```

```

    Lock_W627EHF();
}
//=====
void Set_W627EHF_Reg( unsigned char REG, unsigned char DATA)
{
    Unlock_W627EHF();
    outportb(W627EHF_INDEX_PORT, REG);
    outportb(W627EHF_DATA_PORT, DATA);
    Lock_W627EHF();
}
//=====
unsigned char Get_W627EHF_Reg(unsigned char REG)
{
    unsigned char Result;
    Unlock_W627EHF();
    outportb(W627EHF_INDEX_PORT, REG);
    Result = inportb(W627EHF_DATA_PORT);
    Lock_W627EHF();
    return Result;
}
//=====

//=====
//
// THIS CODE AND INFORMATION IS PROVIDED "AS IS" WITHOUT WARRANTY OF ANY
// KIND, EITHER EXPRESSED OR IMPLIED, INCLUDING BUT NOT LIMITED TO THE
// IMPLIED WARRANTIES OF MERCHANTABILITY AND/OR FITNESS FOR A PARTICULAR
// PURPOSE.
//
//=====
#ifndef __W627EHF_H
#define __W627EHF_H        1
//=====
#define    W627EHF_INDEX_PORT        (W627EHF_BASE)
#define    W627EHF_DATA_PORT        (W627EHF_BASE+1)
//=====
#define    W627EHF_REG_LD            0x07
//=====
#define W627EHF_UNLOCK                0x87
#define    W627EHF_LOCK                0xAA
//=====
unsigned int Init_W627EHF(void);
void Set_W627EHF_LD( unsigned char);
void Set_W627EHF_Reg( unsigned char, unsigned char);
unsigned char Get_W627EHF_Reg( unsigned char);
//=====
#endif    //__W627EHF_H

```

INSTALLATIONS

File of the Main.cpp

```
//=====
// THIS CODE AND INFORMATION IS PROVIDED "AS IS" WITHOUT WARRANTY OF ANY
// KIND, EITHER EXPRESSED OR IMPLIED, INCLUDING BUT NOT LIMITED TO THE
// IMPLIED WARRANTIES OF MERCHANTABILITY AND/OR FITNESS FOR A PARTICULAR
// PURPOSE.
//=====
#include <dos.h>
#include <conio.h>
#include <stdio.h>
#include <stdlib.h>
#include "W627HF.H"
//=====
void ClrKbBuf(void);
int main (int argc, char *argv[]);
//=====
int main (int argc, char *argv[])
{
    unsigned char ucDO = 0;           //data for digital output
    unsigned char ucDI;              //data for digital input
    unsigned char ucBuf;

    Set_W627HF_LD(0x07);              //switch to logic device 7

    Set_W627HF_Reg(0xF1, 0x00);       //clear
    ucDI = Get_W627HF_Reg(0xF1) & 0x0F;

    ClrKbBuf();
    while(1)
    {
        ucDO++;
        Set_W627HF_Reg(0xF1, ((ucDO & 0x0F) << 4));
        ucBuf = Get_W627HF_Reg(0xF1) & 0x0F;
        if (ucBuf != ucDI)
        {
            ucDI = ucBuf;
            printf("Digital I/O Input Changed. Current Data is 0x%X\n",ucDI);
        }

        if (kbhit())
        {
            getch();
            break;
        }
        delay(500);
    }
    return 0;
}
//=====
void ClrKbBuf(void)
{
    while(kbhit())
    {
        getch();
    }
}
//-----
```

BIOS Setup

This chapter describes the different settings available in the Award BIOS that comes with the board. The topics covered in this chapter are as follows:

BIOS Introduction	34
BIOS Setup	34
Standard CMOS Setup	36
Advanced BIOS Features	39
Advanced Chipset Features	42
Integrated Peripherals	44
Power Management Setup	48
PNP/PCI Configurations	51
PC Health Status	52
Frequency/Voltage Control	53
Load Fail-Safe Defaults	54
Load Optimized Defaults	54
Set Supervisor/User Password	54
Save & Exit Setup	54
Exit Without Saving	54

BIOS Introduction

The Award BIOS (Basic Input/Output System) installed in your computer system's ROM supports Intel processors. The BIOS provides critical low-level support for a standard device such as disk drives, serial ports and parallel ports. It also adds virus and password protection as well as special support for detailed fine-tuning of the chipset controlling the entire system.

BIOS Setup

The Award BIOS provides a Setup utility program for specifying the system configurations and settings. The BIOS ROM of the system stores the Setup utility. When you turn on the computer, the Award BIOS is immediately activated. Pressing the key immediately allows you to enter the Setup utility. If you are a little bit late pressing the key, POST (Power On Self Test) will continue with its test routines, thus preventing you from invoking the Setup. If you still wish to enter Setup, restart the system by pressing the "Reset" button or simultaneously pressing the <Ctrl>, <Alt> and <Delete> keys. You can also restart by turning the system Off and back On again. The following message will appear on the screen:

```
Press <DEL> to Enter Setup
```

In general, you press the arrow keys to highlight items, <Enter> to select, the <PgUp> and <PgDn> keys to change entries, <F1> for help and <Esc> to quit.

When you enter the Setup utility, the Main Menu screen will appear on the screen. The Main Menu allows you to select from various setup functions and exit choices.

Phoenix - AwardBIOS CMOS Setup Utility

Standard CMOS Features	Frequency/Voltage Control
Advanced BIOS Features	Load Fail-Safe Defaults
Advanced Chipset Features	Load Optimized Defaults
Integrated Peripherals	Set Supervisor Password
Power Management Setup	Set User Password
PnP/PCI Configurations	Save & Exit Setup
PC Health Status	Exit Without Saving
ESC : Quit	↑ ↓ → ← : Select Item
F10 : Save & Exit Setup	
Time, Date, Hard Disk Type...	

The section below the setup items of the Main Menu displays the control keys for this menu. At the bottom of the Main Menu just below the control keys section, there is another section, which displays information on the currently highlighted item in the list.

Note: *If the system cannot boot after making and saving system changes with Setup, the Award BIOS supports an override to the CMOS settings that resets your system to its default.*

Warning: *It is strongly recommended that you avoid making any changes to the chipset defaults. These defaults have been carefully chosen by both Award and your system manufacturer to provide the absolute maximum performance and reliability. Changing the defaults could cause the system to become unstable and crash in some cases.*

Standard CMOS Setup

“Standard CMOS Setup” choice allows you to record some basic hardware configurations in your computer system and set the system clock and error handling. If the motherboard is already installed in a working system, you will not need to select this option. You will need to run the Standard CMOS option, however, if you change your system hardware configurations, the onboard battery fails, or the configuration stored in the CMOS memory was lost or damaged.

Phoenix - AwardBIOS CMOS Setup Utility
Standard CMOS Features

Date (mm:dd:yy)	Wed, Oct 3, 2007	Item Help
Time (hh:mm:ss)	16 : 11 : 00	Menu Level >
IDE Channel 0 Master	None	Change the day, month, Year and century
IDE Channel 0 Slave	None	
IDE Channel 1 Master	None	
IDE Channel 1 Slave	None	
IDE Channel 2 Master	None	
IDE Channel 3 Master	None	
IDE Channel 4 Master	None	
IDE Channel 4 Slave	None	
Drive A	1.44M, 3.5 in.	
Drive B	None	
Video	EGA/VGA	
Halt On	All , But Keyboard	
Base Memory	640K	
Extended Memory	2086912K	
Total Memory	2087936K	

At the bottom of the menu are the control keys for use on this menu. If you need any help in each item field, you can press the <F1> key. It will display the relevant information to help you. The memory display at the lower right-hand side of the menu is read-only. It will adjust automatically according to the memory changed. The following describes each item of this menu.

Date

The date format is:

- Day :** Sun to Sat
- Month :** 1 to 12
- Date :** 1 to 31
- Year :** 1999 to 2099

To set the date, highlight the “Date” field and use the PageUp/ PageDown or +/- keys to set the current time.

Time

The time format is: **Hour : 00 to 23**
Minute : 00 to 59
Second : 00 to 59

To set the time, highlight the “Time” field and use the <PgUp>/ <PgDn> or +/- keys to set the current time.

IDE Channel Master/Slave

MB930RF-R with ICH9R supports 6 Serial ATA connectors, while MB930-R and MB930F-R with ICH9 supports 4 Serial ATA connectors; MB930-R series boards with JMicron controller support 1 CF and 1 IDE connectors.

The onboard Serial ATA connectors provide Primary and Secondary channels for connecting up to four Serial ATA hard disks . Each channel can support up to two hard disks; the first is the “Master” and the second is the “Slave”.

Press <Enter> to configure the hard disk. The selections include Auto, Manual, and None. Select ‘Manual’ to define the drive information manually. You will be asked to enter the following items.

Capacity : Capacity/size of the hard disk drive
Cylinder : Number of cylinders
Head : Number of read/write heads
Precomp : Write precompensation
Landing Zone : Landing zone
Sector : Number of sectors

The Access Mode selections are as follows:

CHS (HD < 528MB)
LBA (HD > 528MB and supports Logical Block Addressing)
Large (for MS-DOS only)
Auto

Drive A / Drive B

These fields identify the types of floppy disk drive A or drive B that has been installed in the computer. The available specifications are:

360KB	1.2MB	720KB	1.44MB	2.88MB
5.25 in.	5.25 in.	3.5 in.	3.5 in.	3.5 in.

Video

This field selects the type of video display card installed in your system.

You can choose the following video display cards:

EGA/VGA	For EGA, VGA, SEGA, SVGA or PGA monitor adapters. (default)
CGA 40	Power up in 40 column mode.
CGA 80	Power up in 80 column mode.
MONO	For Hercules or MDA adapters.

Halt On

This field determines whether or not the system will halt if an error is detected during power up.

No errors	The system boot will not be halted for any error that may be detected.
All errors	Whenever the BIOS detects a non-fatal error, the system will stop and you will be prompted.
All, But Keyboard	The system boot will not be halted for a keyboard error; it will stop for all other errors
All, But Diskette	The system boot will not be halted for a disk error; it will stop for all other errors.
All, But Disk/Key	The system boot will not be halted for a keyboard or disk error; it will stop for all others.

Advanced BIOS Features

This section allows you to configure and improve your system and allows you to set up some system features according to your preference.

Phoenix - AwardBIOS CMOS Setup Utility
Advanced BIOS Features

		ITEM HELP
CPU Feature	Press Enter	
Removable Device Priority	Press Enter	
Hard Disk Boot Priority	Press Enter	
Virus Warning	Disabled	Menu Level >
Quick Power On Self Test	Enabled	
First Boot Device	Removable	
Second Boot Device	Hard Disk	
Third Boot Device	CDROM	
Boot Other Device	Enabled	
Swap Floppy Drive	Disabled	
Boot Up Floppy Seek	Disabled	
Boot Up NumLock Status	On	
Gate A20 Option	Fast	
Typematic Rate Setting	Disabled	
Typematic Rate (Chars/Sec)	6	
Typematic Delay (Msec)	250	
Security Option	Setup	
APIC Mode	Enabled	
MPS Version Control for OS	1.4	
OS Select For DRAM>64MB	Non-OS2	
Report No FDD For WIN 95	Yes	
Small Logo (EPA) Show	Disabled	

CPU Feature

Press Enter to configure the settings relevant to CPU Feature.

Hard Disk Boot Priority

With the field, there is the option to choose, aside from the hard disks connected, "Bootable add-in Cards" which refers to other external devices.

Removable Device Priority

Press Enter to configure the device priority order.

Virus Warning

If this option is enabled, an alarm message will be displayed when trying to write on the boot sector or on the partition table on the disk, which is typical of the virus.

Quick Power On Self Test

When enabled, this field speeds up the Power On Self Test (POST) after the system is turned on. If it is set to *Enabled*, BIOS will skip some items.

First/Second/Third Boot Device

These fields determine the drive that the system searches first for an operating system. The options available include *Removable*, *Hard Disk*, *CDROM*, *Legacy LAN* and *Disabled*.

Boot Other Device

These fields allow the system to search for an OS from other devices other than the ones selected in the First/Second/Third Boot Device.

Swap Floppy Drive

This item allows you to determine whether or not to enable Swap Floppy Drive. When enabled, the BIOS swaps floppy drive assignments so that Drive A becomes Drive B, and Drive B becomes Drive A. By default, this field is set to *Disabled*.

Boot Up Floppy Seek

This feature controls whether the BIOS checks for a floppy drive while booting up. If it cannot detect one (either due to improper configuration or its absence), it will flash an error message.

Boot Up NumLock Status

This allows you to activate the NumLock function after you power up the system.

Gate A20 Option

This field allows you to select how Gate A20 is worked. Gate A20 is a device used to address memory above 1 MB.

Typematic Rate Setting

When disabled, continually holding down a key on your keyboard will generate only one instance. When enabled, you can set the two typematic controls listed next. By default, this field is set to *Disabled*.

Typematic Rate (Chars/Sec)

When the typematic rate is enabled, the system registers repeated keystrokes speeds. Settings are from 6 to 30 characters per second.

Typematic Delay (Msec)

When the typematic rate is enabled, this item allows you to set the time interval for displaying the first and second characters. By default, this item is set to *250msec*.

Security Option

This field allows you to limit access to the System and Setup. The default value is *Setup*. When you select *System*, the system prompts for the User Password every time you boot up. When you select *Setup*, the system always boots up and prompts for the Supervisor Password only when the Setup utility is called up.

APIC Mode

APIC stands for Advanced Programmable Interrupt Controller. The default setting is *Enabled*.

MPS Version Control for OS

This option specifies the MPS (Multiprocessor Specification) version for the OS. MPS version 1.4 added extended configuration tables to improve support for multiple PCI bus configurations and improve future expandability. The default setting is *1.4*.

OS Select for DRAM > 64MB

This option allows the system to access greater than 64MB of DRAM memory when used with OS/2 that depends on certain BIOS calls to access memory. The default setting is *Non-OS/2*.

Report No FDD For WIN 95

If you are using Windows 95/98 without a floppy disk drive, select Enabled to release IRQ6. This is required to pass Windows 95/98's SCT test. You should also disable the Onboard FDC Controller in the Integrated Peripherals screen when there's no floppy drive in the system. If you set this feature to Disabled, the BIOS will not report the missing floppy drive to Win95/98.

Small Logo (EPA) Show

The EPA logo appears at the right side of the monitor screen when the system is boot up. The default setting is *Disabled*.

Advanced Chipset Features

This Setup menu controls the configuration of the chipset.

Phoenix - AwardBIOS CMOS Setup Utility
Advanced Chipset Features

		ITEM HELP
DRAM Timing Selectable	By SPD	Menu Level >
CAS Latency Time	Auto	
DRAM RAS# to CAS# Delay	Auto	
DRAM RAS# Precharge	Auto	
Precharge delay (tRAS)	Auto	
System Memory Frequency	By SPD	
System BIOS Cacheable	Enabled	
Memory Hole at 15M-16M	Disabled	
PCI Express Root Port Func	Press Enter	
** VGA Setting **		
PEG/On Chip VGA Control	Auto	
On-Chip Frame Buffer Size	8MB	
DVMT Mode	DVMT	
DVMT/FIXED memory Size	128MB	

DRAM Timing Selectable

This option refers to the method by which the DRAM timing is selected. The default is **By SPD**.

CAS Latency Time

You can select CAS latency time in HCLKs of 3/3 or 4/4. The system board designer should set the values in this field, depending on the DRAM installed. Do not change the values in this field unless you change specifications of the installed DRAM or the installed CPU. The choices are 3, 4 and 5.

DRAM RAS# to CAS# Delay

This option allows you to insert a delay between the RAS (Row Address Strobe) and CAS (Column Address Strobe) signals. This delay occurs when the SDRAM is written to, read from or refreshed. Reducing the delay improves the performance of the SDRAM.

DRAM RAS# Precharge

This option sets the number of cycles required for the RAS to accumulate its charge before the SDRAM refreshes.

Precharge delay (tRAS)

The default setting for the Active to Precharge Delay is Auto.

System Memory Frequency

This field sets the frequency of the DRAM memory installed. The default setting is *Auto*. The other settings are *DDR667* and *DDR800*.

System BIOS Cacheable

The setting of *Enabled* allows caching of the system BIOS ROM at F000h-FFFFh, resulting in better system performance. However, if any program writes to this memory area, a system error may result.

Memory Hole At 15M-16M

In order to improve performance, certain space in memory can be reserved for ISA cards. This memory must be mapped into the memory space below 16 MB. The choices are *Enabled* and *Disabled*.

PCI Express Root Port Func

Press Enter to configure this field.

VGA Setting

The fields under the On-Chip VGA Setting and their default settings are:

PEG/On Chip VGA Control: Auto

On-Chip Frame Buffer Size: 8MB

DVMT Mode: DVMT

DVMT/Fixed Memory Size: 128MB

Integrated Peripherals

This section sets configurations for your hard disk and other integrated peripherals. The first screen shows three main items for user to select. Once an item selected, a submenu appears. Details follow.

Phoenix - AwardBIOS CMOS Setup Utility
Integrated Peripherals

OnChip IDE Device	Press Enter	ITEM HELP
SuperIO Device	Press Enter	Menu Level >
2 nd SuperIO Device	Press Enter	
USB Device Setting	Press Enter	

Phoenix - AwardBIOS CMOS Setup Utility
OnChip IDE Device

IDE HDD Block Mode	Enabled	ITEM HELP
IDE DMA transfer access	Enabled	Menu Level >
IDE Primary Master PIO	Auto	
IDE Primary Slave PIO	Auto	
IDE Primary Master UDMA	Auto	
IDE Primary Slave UDMA	Auto	
On-Chip Secondary PCI IDE	Enabled	
IDE Secondary Master PIO	Auto	
IDE Secondary Slave PIO	Auto	
IDE Secondary Master UDMA	Auto	
IDE Secondary Slave UDMA	Auto	
SATA Mode	IDE	
LEGACY Mode Support	Enabled	
Robson Support	Disabled	

Phoenix - AwardBIOS CMOS Setup Utility
SuperIO Device

POWER ON Function	BUTTON ONLY	ITEM HELP
KB Power ON Password	Enter	Menu Level >
Hot Key power ON	Ctrl-F1	
Onboard FDC Controller	Enabled	
Onboard Serial Port 1	3F8/IRQ4	
Onboard Serial Port 2	2F8/IRQ3	
UART Mode Select	Normal	
RxD , TxD Active	Hi, Lo	
IR Transmission Delay	Enabled	
UR2 Duplex Mode	Half	
Use IR Pins	IR-Rx2Tx2	
Onboard Parallel Port	378/IRQ7	
Parallel Port Mode	SPP	
EPP Mode Select	EPP1.7	
ECP Mode Use DMA	3	
PWRON After PWR-Fail	Off	

Phoenix - AwardBIOS CMOS Setup Utility

2nd Super IO Device

Onboard Serial Port 3	230h	ITEM HELP
Serial Port 3 Use IRQ	IRQ10	Menu Level >
Onboard Serial Port 4	238h	
Serial Port 4 Use IRQ	IRQ11	

Phoenix - AwardBIOS CMOS Setup Utility

USB Device Setting

USB 1.0 Controller	Enabled	ITEM HELP
USB 2.0 Controller	Enabled	Menu Level >
USB Keyboard Function	Enabled	
USB Mouse Function	Enabled	
USB Storage Function	Enabled	
*** USB Mass Storage Device Boot Setting ***		

IDE HDD Block Mode

This field allows your hard disk controller to use the fast block mode to transfer data to and from your hard disk drive.

IDE DMA Transfer Access

This field, by default, is enabled

OnChip Secondary PCI IDE

This field, by default, is enabled

IDE Primary/Secondary Master/Slave PIO

These fields allow your system hard disk controller to work faster. Rather than have the BIOS issue a series of commands that transfer to or from the disk drive, PIO (Programmed Input/Output) allows the BIOS to communicate with the controller and CPU directly.

The system supports five modes, numbered from 0 (default) to 4, which primarily differ in timing. When Auto is selected, the BIOS will select the best available mode.

IDE Primary/Secondary Master/Slave UDMA

These fields allow your system to improve disk I/O throughput to 33Mb/sec with the Ultra DMA/33 feature. The options are *Auto* and *Disabled*.

SATA Mode

The setting choices for the SATA Mode are IDE, RAID and AHCI Mode. Select [IDE] if you want to have SATA function as IDE. Select [AHCI] for Advanced Host Controller Interface (AHCI) feature, with improved SATA performance with native command queuing & native hot plug. Select [RAID] to use SATA as RAID function. RAID function is supported on the board if it uses ICH9R. (***MB930RF-R supports 6 x SATA with RAID.***)

LEGACY Mode Support

When the Serial ATA (SATA) is set with the legacy mode enabled, then the SATA is set to the conventional IDE mode. Legacy mode is otherwise known as compatible mode.

Robson Support

This field, by default, is disabled.

PWRON After PWR-Fail

This field sets the system power status whether *on* or *off* when power returns to the system from a power failure situation.

Power ON Function

This field is related to how the system is powered on – such as with the use of conventional power button, keyboard or hot keys. The default is ***BUTTON ONLY.***

KB Power ON Password

This field allows users to set the password when keyboard power on is the mode of the Power ON function.

Hot Key Power ON

This field sets certain keys, also known as hot keys, on the keyboard that can be used as a ‘switch’ to power on the system.

Onboard FDC Controller

Select *Enabled* if your system has a floppy disk controller (FDC) installed on the motherboard and you wish to use it. If you install an add-in FDC or the system has no floppy drive, select Disabled in this field. This option allows you to select the onboard FDD port.

Onboard Serial/Parallel Port

These fields allow you to select the onboard serial and parallel ports and their addresses. The default values for these ports are:

Serial Port 1	3F8/IRQ4
Serial Port 2	2F8/IRQ3
Serial Port 3	230/IRQ10
Serial Port 4	238/IRQ11
Parallel Port	378H/IRQ7

UART Mode Select

This field determines the UART 2 mode in your computer. The default value is *Normal*. Other options include *IrDA* and *ASKIR*.

Parallel Port Mode

This field allows you to determine parallel port mode function.

SPP	Standard Printer Port
EPP	Enhanced Parallel Port
ECP	Extended Capabilities Port
ECP+EPP	Combination of ECP and EPP capabilities
Normal	Normal function

USB 1.0 Controller

The options for this field are *Enabled* and *Disabled*. By default, this field is set to *Enabled*.

USB 2.0 Controller

The options for this field are *Enabled* and *Disabled*. By default, this field is set to *Enabled*. In order to use USB 2.0, necessary OS drivers must be installed first. *Please update your system to Windows 2000 SP4 or Windows XP SP2.*

USB Keyboard/Mouse/Storage Function

The options for this field are *Enabled* and *Disabled*. By default, this field is set to *Disabled*.

Power Management Setup

Phoenix - AwardBIOS CMOS Setup Utility
Power Management Setup

		ITEM HELP
ACPI Function	Enabled	Menu Level >
ACPI Suspend	S1(POS)	
Run VGABIOS if S3 Resume	Auto	
Power Management	User Define	
Video Off Method	V/H SYNC+Blank	
Video Off In Suspend	Yes	
Suspend Type	Stop Grant	
Modem Use IRQ	3	
Suspend Mode	Disabled	
HDD Power Down	Disabled	
Soft-Off by PWR-BTTN	Instant-Off	
CPU THRM-Throttling	50.0%	
Wake-Up by PCI Card	Disabled	
Power On by Ring	Disabled	
Resume by Alarm	Disabled	
Date (of Month) Alarm	0	
Time (hh:mm:ss) Alarm	0 : 0 : 0	
** Reload Global Timer Events **		
Primary IDE 0	Enabled	
Primary IDE 1	Enabled	
Secondary IDE 0	Enabled	
Secondary IDE 1	Enabled	
FDD, COM, LPT Port	Enabled	
PCI PIRQ[A-D] #	Enabled	
HPET Support	Enabled	
HPET Mode	32-bit mode	

ACPI Function

Enable this function to support ACPI (Advance Configuration and Power Interface).

ACPI Suspend

The default setting of the ACPI Suspend mode is *SI(POS)*.

RUN VGABIOS if S3 Resume

The default setting of this field is *Auto*.

Power Management

This field allows you to select the type of power saving management modes. There are four selections for Power Management.

Min. Power Saving	Minimum power management
Max. Power Saving	Maximum power management.
User Define	Each of the ranges is from 1 min. to 1hr. Except for HDD Power Down which ranges from 1 min. to 15 min.

Video Off Method

This field defines the Video Off features. There are three options.

V/H SYNC + Blank	Default setting, blank the screen and turn off vertical and horizontal scanning.
DPMS	Allows BIOS to control the video display.
Blank Screen	Writes blanks to the video buffer.

Video Off In Suspend

When enabled, the video is off in suspend mode.

Suspend Type

The default setting for the Suspend Type field is *Stop Grant*.

Modem Use IRQ

This field sets the IRQ used by the Modem. By default, the setting is 3.

Suspend Mode

When enabled, and after the set time of system inactivity, all devices except the CPU will be shut off.

HDD Power Down

When enabled, and after the set time of system inactivity, the hard disk drive will be powered down while all other devices remain active.

Soft-Off by PWRBTN

This field defines the power-off mode when using an ATX power supply. The *Instant Off* mode allows powering off immediately upon pressing the power button. In the *Delay 4 Sec* mode, the system powers off when the power button is pressed for more than four seconds or enters the suspend mode when pressed for less than 4 seconds.

CPU THRM-Throttling

When the system enters Doze mode, the CPU clock runs only part of the time. You may select the percent of time that the clock runs.

Wake up by PCI Card

By default, this field is *Disabled*.

Power On by Ring

This field enables or disables the power on of the system through the modem connected to the serial port or LAN.

Resume by Alarm

This field enables or disables the resumption of the system operation. When enabled, the user is allowed to set the *Date* and *Time*.

Reload Global Timer Events

The HDD, FDD, COM, LPT Ports, and PCI PIRQ are I/O events that can prevent the system from entering a power saving mode or can awaken the system from such a mode. When an I/O device wants to gain the attention of the operating system, it signals this by causing an IRQ to occur. When the operating system is ready to respond to the request, it interrupts itself and performs the service.

HPET Support

HPET stands for High Precision Event Timer. HPET can produce periodic interrupts at a much higher resolution than the RTC and is used to synchronize multimedia streams, providing smooth playback and reducing the need to use other timestamp calculations such as an x86 CPU's RDTSC instruction. HPET is not supported in Windows XP, Windows Server 2003, or earlier Windows versions. HPET is supported under Linux and Windows Vista. By default, this field is enabled.

HPET Mode

By default, this field is set to *32-bit mode*.

PNP/PCI Configurations

This option configures the PCI bus system. All PCI bus systems on the system use INT#, thus all installed PCI cards must be set to this value.

Phoenix - AwardBIOS CMOS Setup Utility
PnP/PCI Configurations

PNP OS Installed	No	ITEM HELP Menu Level
Init Display First	PCI Slot	
Reset Configuration Data	Disabled	Select Yes if you are using a Plug and Play capable operating system Select No if you need the BIOS to configure non-boot devices
Resources Controlled By	Auto (ESCD)	
IRQ Resources	Press Enter	
DMA Resources	Press Enter	
PCI/VGA Palette Snoop	Disabled	
PCI Express relative items		
Maximum Payload Size	128	

PNP OS Install

Enable the PNP OS Install option if it is supported by the operating system installed. The default value is *No*.

Init Display First

The default setting is *PCI Card*.

Reset Configuration Data

The default value is *Disabled*.

Resources Controlled by

This PnP BIOS can configure all of the boot and compatible devices with the use of a PnP operating system such as Windows 95.

PCI/VGA Palette Snoop

Some non-standard VGA display cards may not show colors properly. This field allows you to set whether or not MPEG ISA/VESA VGA cards can work with PCI/VGA. When this field is enabled, a PCI/VGA can work with an MPEG ISA/VESA VGA card. When this field is disabled, a PCI/VGA cannot work with an MPEG ISA/VESA card.

Maximum Payload Size

The default setting of the PCI Express Maximum Payload Size is 128.

PC Health Status

Phoenix - AwardBIOS CMOS Setup Utility
PC Health Status

Shutdown Temperature	Disabled	ITEM HELP
CPU Warning Temperature	Disabled	
Current System Temp	32°C/89°F	Menu Level >
Current CPU Temp	39°C/102°F	
System Fan Speed	0 RPM	
CPU Fan Speed	4440 RPM	
System Fan Speed	0 RPM	
Vcore	1.31 V	
12 V	12.19 V	
1.8 V	1.90 V	
5 V	5.14 V	
3.3 V	3.32 V	
VBAT (V)	3.21 V	
5VSB(V)	5.55 V	

CPU Warning Temperature

This field allows the user to set the temperature so that when the temperature is reached, the system sounds a warning. This function can help prevent damage to the system that is caused by overheating.

Shutdown Temperature

This field allows the user to set the temperature by which the system automatically shuts down once the threshold temperature is reached. This function can help prevent damage to the system that is caused by overheating.

Temperatures/Fan Speeds/Voltages

These fields are the parameters of the hardware monitoring function feature of the board. The values are read-only values as monitored by the system and show the PC health status.

Frequency/Voltage Control

Phoenix - AwardBIOS CMOS Setup Utility
Frequency/Voltage Control

Auto Detect PCI Clk	Disabled	ITEM HELP
Spread Spectrum	Disabled	Menu Level >

Auto Detect PCI Clk

This field enables or disables the auto detection of the PCI clock.

Spread Spectrum

This field sets the value of the spread spectrum. The default setting is *Disabled*. This field is for CE testing use only.

Load Fail-Safe Defaults

This option allows you to load the troubleshooting default values permanently stored in the BIOS ROM. These default settings are non-optimal and disable all high-performance features.

Load Optimized Defaults

This option allows you to load the default values to your system configuration. These default settings are optimal and enable all high performance features.

Set Supervisor/User Password

These two options set the system password. Supervisor Password sets a password that will be used to protect the system and Setup utility. User Password sets a password that will be used exclusively on the system. To specify a password, highlight the type you want and press <Enter>. The Enter Password: message prompts on the screen. Type the password, up to eight characters in length, and press <Enter>. The system confirms your password by asking you to type it again. After setting a password, the screen automatically returns to the main screen.

To disable a password, just press the <Enter> key when you are prompted to enter the password. A message will confirm the password to be disabled. Once the password is disabled, the system will boot and you can enter Setup freely.

Save & Exit Setup

This option allows you to determine whether or not to accept the modifications. If you type “Y”, you will quit the setup utility and save all changes into the CMOS memory. If you type “N”, you will return to Setup utility.

Exit Without Saving

Select this option to exit the Setup utility without saving the changes you have made in this session. Typing “Y” will quit the Setup utility without saving the modifications. Typing “N” will return you to Setup utility.

Drivers Installation

This section describes the installation procedures for software and drivers under the Windows 2000, Windows XP and Windows Vista. The software and drivers are included with the board. If you find the items missing, please contact the vendor where you made the purchase. The contents of this section include the following:

Intel Chipset Software Installation Utility.....	56
Intel Chipset Graphics Driver	58
Realtek HD Codec Audio Driver Installation	59
LAN Drivers Installation.....	60

IMPORTANT NOTE:

After installing your Windows operating system (Windows 2000/XP/Vista), you must install first the Intel Chipset Software Installation Utility before proceeding with the drivers installation.

Intel Chipset Software Installation Utility

The Intel® Chipset Drivers should be installed first before the software drivers to enable Plug & Play INF support for Intel chipset components. Follow the instructions below to complete the installation under Windows 2000/XP/Vista. (Before installed Intel Chipset Software Installation Utility, Please update your system to Windows 2000 SP4 or Windows XP SP1A)

1. Insert the DVD that comes with the board. Click **Intel Chipsets** and then **Intel(R) Bearlake Chipset Family Drivers**.
2. Click **Intel(R) Chipset Software Installation Utility**.

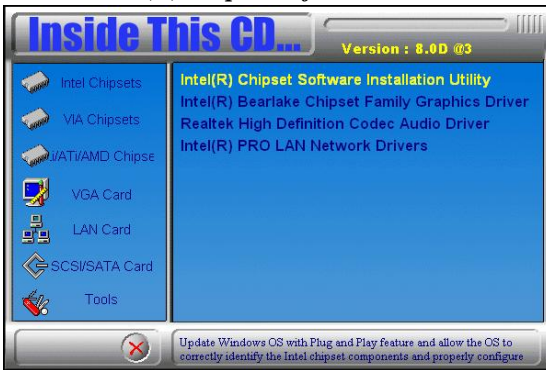

3. When the Welcome screen appears, click **Next** to continue.



4. Click **Yes** to accept the software license agreement and proceed with the installation process.
5. On the Readme Information screen, click **Next** to continue the installation.
6. When the Setup Progress screen appears, click **Next** to continue.
7. The Setup process is now complete. Click **Finish** then restart the computer and for changes to take effect.



Intel Graphics Driver Installation

To install the Graphics drivers, follow the steps below to proceed with the installation.

1. Insert the DVD that comes with the board. Click **Intel Chipsets** and then **Intel(R) Bearlake Chipset Family Drivers**.

2. Click **Intel(R) Bearlake Chipset Family Graphics Driver**.

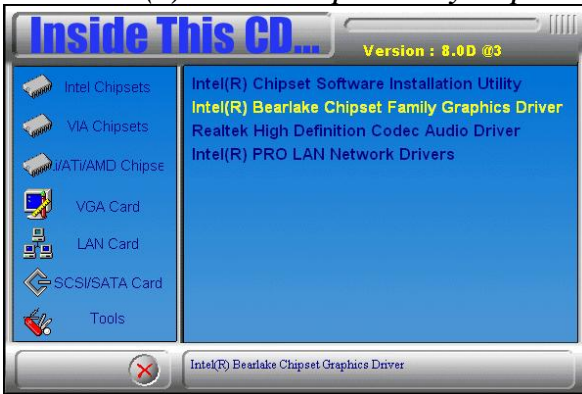

3. When the Welcome screen appears, click **Next** to continue.

4. Click **Yes** to accept the software license agreement and proceed with the installation process.

5. On Readme File Information screen, click **Next** to continue.

6. On Setup Progress screen, click **Next** to continue the installation.

7. The Setup process is now complete. Click **Finish** to restart the computer and for changes to take effect.

Realtek HD Code Audio Driver Installation

Follow the steps below to install the Realtek High Definition Codec Audio Driver.

1. Insert the DVD that comes with the board. Click **Intel Chipsets** and then **Intel(R) Bearlake Chipset Family Drivers**.

2. Click **Realtek High Definition Codec Audio Driver**.

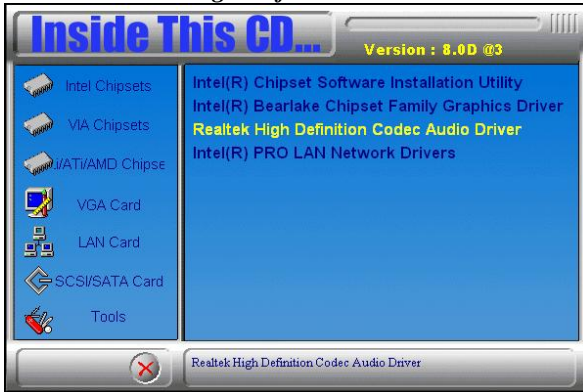

3. When the Welcome screen appears, click **Next** to continue.

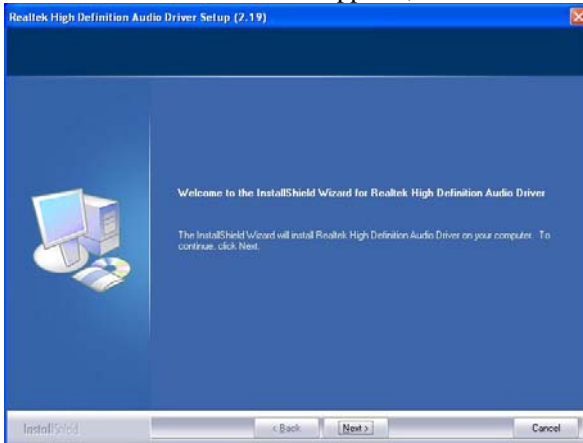

4. The Setup process is now complete. Restart the computer when prompted for changes to take effect.

LAN Drivers Installation

Follow the steps below to start installing the Intel 82566DM or Intel 82562V drivers.

1. Insert the DVD that comes with the board. Click **Intel Chipsets** and then **Intel(R) Bearlake Chipset Family Drivers**.
2. Click **Intel(R) PRO LAN Network Drivers**.



3. On the next screen, click **Install Drivers** to start the drivers installation.
4. When the Welcome screen appears, click **Next** to continue.
5. In the License Agreement screen, click **I accept the terms in license agreement** and **Next** to accept the software license agreement and proceed with the installation process.
6. When the Setup Options appears, click **Install Drivers only** and **Next** to continue.
7. When the Ready to Install the Program screen appears, click **Install** to continue.
8. The Setup process is now complete (InstallShield Wizard Completed). Click **Finish** to restart the computer and for changes to take effect.

Follow the steps below to use the wake up function by Intel 82566DM or Intel 82562V.

1. The BIOS Setup item “Wake-Up by PCI card” has to be set as [Enabled] .
2. Go to the Device Manager under Windows and select Network adapters. The following window will appear (Intel(R) 82566DM Gigabit Network Connection Properties). Click **Power Management** and select **Wake on Magic Packet from power off states** .

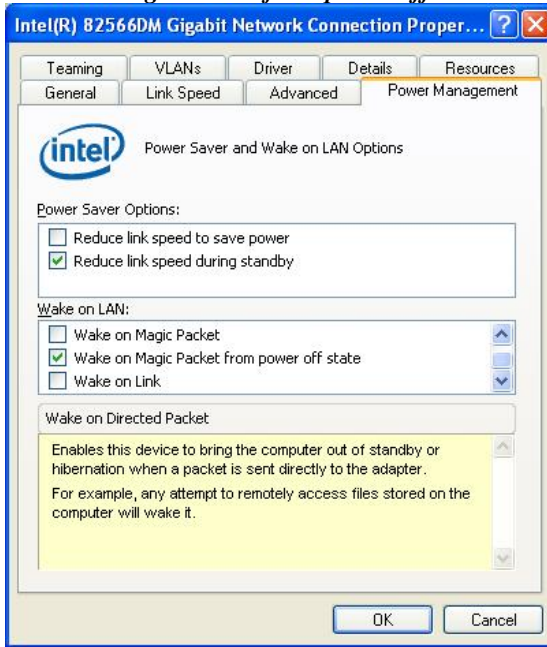

3. Turn off computer .

Follow the steps below to install the **Marvell Gigabit LAN** drivers.

1. Insert the DVD that comes with the board. Click **LAN Card** and then **Marvell LAN Controller Driver**.

2. Click **Next** when the InstallShield Wizard welcome screen appears.

3. Click **Next** to agree with the license agreement.

4. Click **Install when the Ready** to Install the Program screen appears to proceed with the drives installation process.

5. When the Installation is complete, click **Finish** for the changes to take effect.

6. To use the wake up function by Marvell Gigabit LAN, go to the **Device Manager** under Windows and select **Network adapters**. The following window will appear (Generic Marvell Yukon Chipset based Ethernet Controller Properties). Click **Advanced** and select **Wake From Shutdown**. In the Value field on the right, select **On**.

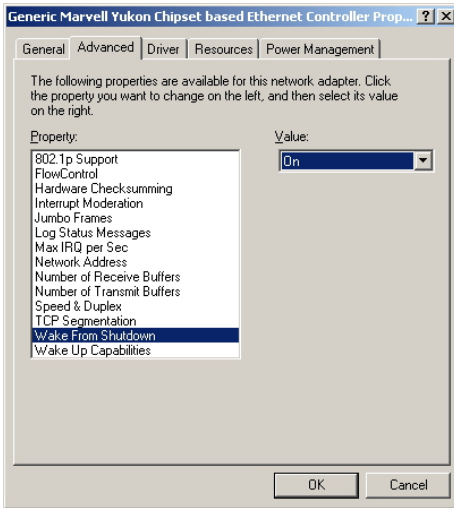

7. Then, also in the Advanced section, click on **Wake Up Capabilities**. In the Value field on the right, select **Magic Packet**, then click **OK**.

9. Turn off computer .

Appendix

A. I/O Port Address Map

Each peripheral device in the system is assigned a set of I/O port addresses that also becomes the identity of the device. The following table lists the I/O port addresses used.

Address	Device Description
000h - 01Fh	DMA Controller #1
020h - 03Fh	Interrupt Controller #1
040h - 05Fh	Timer
060h - 06Fh	Keyboard Controller
070h - 07Fh	Real Time Clock, NMI
080h - 09Fh	DMA Page Register
0A0h - 0BFh	Interrupt Controller #2
0C0h - 0DFh	DMA Controller #2
0F0h	Clear Math Coprocessor Busy Signal
0F1h	Reset Math Coprocessor
1F0h - 1F7h	IDE Interface
278h - 27Fh	Parallel Port #2(LPT2)
2F8h - 2FFh	Serial Port #2(COM2)
2B0h - 2DFh	Graphics adapter Controller
378h - 3FFh	Parallel Port #1(LPT1)
360h - 36Fh	Network Ports
3B0h - 3BFh	Monochrome & Printer adapter
3C0h - 3CFh	EGA adapter
3D0h - 3DFh	CGA adapter
3F0h - 3F7h	Floppy Disk Controller
3F8h - 3FFh	Serial Port #1(COM1)

B. Interrupt Request Lines (IRQ)

Peripheral devices use interrupt request lines to notify CPU for the service required. The following table shows the IRQ used by the devices on board.

Level	Function
IRQ0	System Timer Output
IRQ1	Keyboard
IRQ2	Interrupt Cascade
IRQ3	Serial Port #2
IRQ4	Serial Port #1
IRQ5	Reserved
IRQ6	Floppy Disk Controller
IRQ7	Parallel Port #1
IRQ8	Real Time Clock
IRQ9	Reserved
IRQ10	Reserved
IRQ11	Reserved
IRQ12	PS/2 Mouse
IRQ13	80287
IRQ14	Primary IDE
IRQ15	Secondary IDE