

LPC 15" Series

15" Multifunctional Touch Panel PC

Quick Reference Guide

1st Ed – 9 Mar. 2010

Copyright Notice

Copyright © 2010 Avalue Technology Inc., ALL RIGHTS RESERVED.

Contents

1.	Getting Started	3
1.1	Safety Precautions	3
1.2	Packing List.....	3
1.3	System Specifications	4
1.4	System Overview	6
1.4.1	Front View.....	6
1.4.2	Rear View	6
1.5	System Dimensions	7
2.	Hardware Configuration	8
2.1	Jumper and Connector Setting , Driver and BIOS Installing	9
2.1.1	LPC-1503 RS232/422/485 setting by BIOS.....	9
2.2	Installing Hard Disk & Memory	10

1. Getting Started

1.1 Safety Precautions

Warning!



Always completely disconnect the power cord from your chassis whenever you work with the hardware. Do not make connections while the power is on. Sensitive electronic components can be damaged by sudden power surges. Only experienced electronics personnel should open the PC chassis.

Caution!



Always ground yourself to remove any static charge before touching the CPU card. Modern electronic devices are very sensitive to static electric charges. As a safety precaution, use a grounding wrist strap at all times. Place all electronic components in a static-dissipative surface or static-shielded bag when they are not in the chassis.



1.2 Packing List



- 1 x LPC 15" Series Panel PC
- 1 x Quick Reference Guide
- 1 x DVD-ROM contains the followings:
 - User's Manual (this manual in PDF file)
 - Ethernet driver and utilities
 - VGA drivers and utilities
 - Audio drivers and utilities
 - WiFi drivers and utilities
 - Touch controller drivers and utilities
- 1 x Power Adapter



If any of the above items is damaged or missing, contact your retailer.

1.3 System Specifications

Panel 	
Model	LPC-1503
LCD size	15", 4:3
Display type	XGA
Resolution	1024 x 768
Color	262K
Pixel pitch	0.297mm(H) x 0.297mm(V)
Luminance	250 cd/m ²
Contrast ratio	500
Viewing angle	65(U), 60(D), 70(L), 70(R)
Response time	8 ms
Backlight	CCFL
Touch type	5 Wires resistive
Touch interface	USB
System 	
Board	EBM-945GSE
CPU	Onboard Intel Atom N270 1.6GHz (2.5W)
BIOS	Award 8 Mbit Flash BIOS
System Chipset	Intel 945GSE + ICH7-M
I/O Chipset	ITE 8712F
System Memory	Onboard 1GB DDR2, extra one SODIMM supports up to 2GB 400/533 SDRAM
SSD	One CF socket supports Type I / II Compact Flash Card.
HDD	Optional 2.5" SATA HDD or 44-pin enhanced IDE HDD
WiFi	Optional USB WiFi 802.11b/g
Watchdog Timer	Reset: 1 ~ 65535 sec./min. and 1 min./step
Display	Intel 945GSE GMCH integrated GMA950 graphics
Audio	Realtek ALC 655 supports 5.1-CH Audio
Ethernet	Dual Realtek RTL8111C Gigabit LAN, supports wake on LAN

External I/O Ports 	
COM Port	1 x RS-232/422/485 setting by BIOS*, optional extra 1 x RS-232/422/485
Ethernet Port	Dual RTL8111C Giga LAN
VGA / LCD Port	1 x DB-15
Audio Port	Line-out
USB Port	2 x USB 2.0
Power Supply Unit 	
Power Input	12V
Power Output	5A (60W)
Environment & Mechanical 	
Operating Temperature	0~40°C (32~104°F)
Storage Temperature	-20 to 60°C (-4~140°F)
Relative Humidity	5 to 90% @ 40°C (104°F), relative humidity, non-condensing
Dimension (W x D x H)	351.5 x 272 x 52 mm
Weight	4.2 Kgs
Mounting	Desktop (VESA Compliance)



Note: *To know more detail of RS232/422/485 setting by BIOS, please refer to chapter 2.1.

1.4 System Overview

1.4.1 Front View

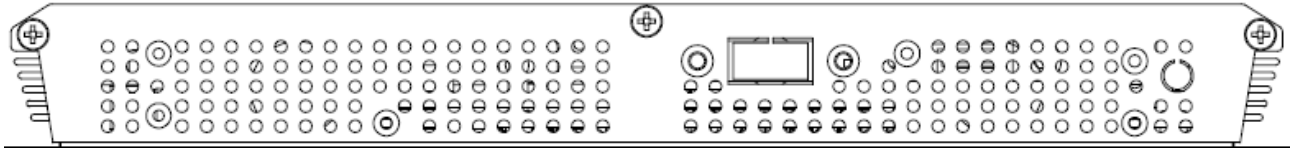

1.4.2 Rear View

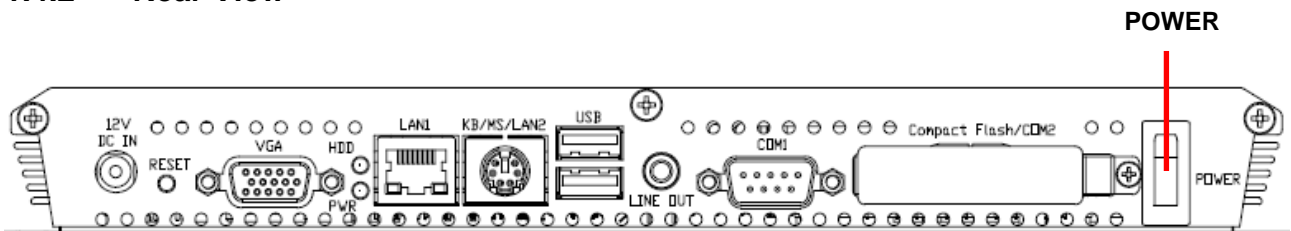

Connectors

Label	Function	Note
POWER	Power on button	
CF	CF Type I/II Socket with Ejector	Optional for 2 nd COM port
COM	Serial port	DB-9 male connector
LINE OUT	Line-out audio jack	
USB	2 x USB 2.0 connector	Dock USB
LAN1	RJ-45 Ethernet connector 1	
LAN2	RJ-45 Ethernet connector 2	
(KB/MS)	(LAN2 is default, KB/MS is optional)	
HDD	HDD indicator	
PWR	System power indicator	
VGA	CRT connector	DB-15 female connector
RESET	Reset button	
DC-IN	DC Power-in connector	

1.5 System Dimensions

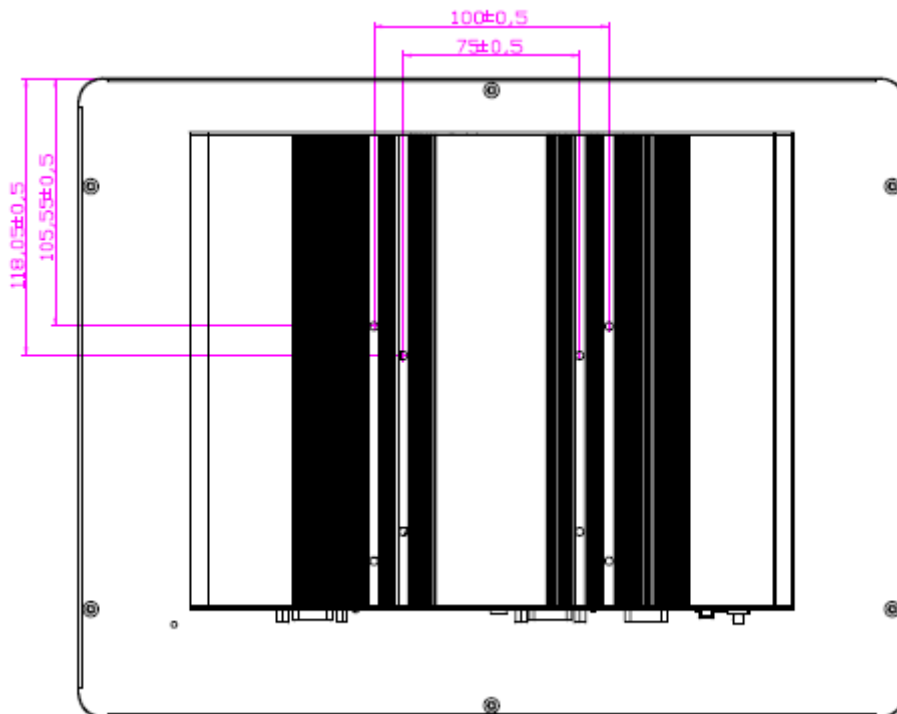
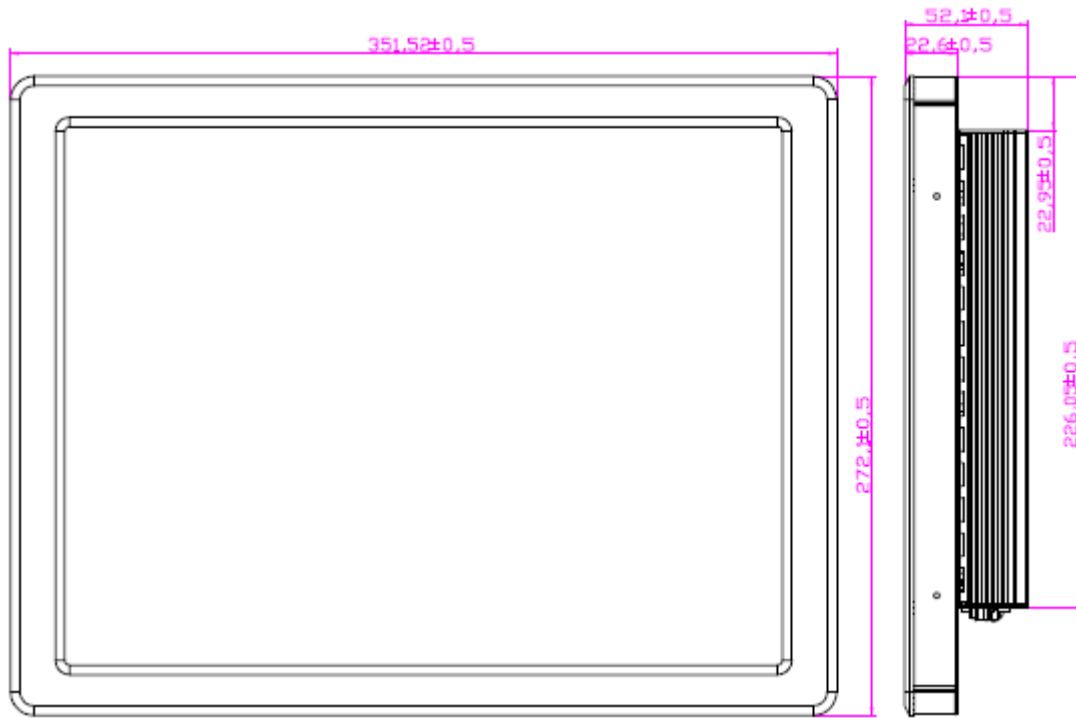

2. Hardware Configuration



Note: If you need more information, please visit our website:

<http://www.avalue.com.tw>

2.1 Jumper and Connector Setting , Driver and BIOS Installing

2.1.1 LPC-1503 RS232/422/485 setting by BIOS

The COM port setting of LPC-1503, which applying EBM-945GSE M/B, can be configured by BIOS. The path is shown as below.

**[BIOS Menu] → [Integrated Peripherals] → [Super IO Device]
→ [COMPORT 232/422/485]**

Phoenix – AwardBIOS CMOS Setup Utility		Item Help
SuperIO Device		Menu Level ▶
Onboard Serial Port 1	[3F8/IRQ4]	
COM1 232/422/485	[RS232]	
Onboard Serial Port 2	[2F8/IRQ3]	
COM2 232/422/485	[RS232]	
PWRON After PWR-Fail	[Off]	
Watch Dog Timer Select	[Disabled]	
Onboard Serial Port 3	[3E8]	
Serial Port 3 Use IRQ	[IRQ5]	
Onboard Serial Port 4	[2E8]	
Serial Port 4 Use IRQ	[IRQ10]	
Onboard Serial Port 5	[218]	
Serial Port 5 Use IRQ	[IRQ5]	
Onboard Serial Port 6	[208]	
Serial Port 6 Use IRQ	[IRQ10]	
Serial Port 3 Mode	[Normal]	

The panel backlight of LPC-1503, which applying EBM-945GSE M/B, can be configured by BIOS as well. The path is shown as below.

[BIOS Menu] → [Advanced Chipset Features] → [LVDS Back Light]

To know more about other settings, please refer to **EBM-945GSE** Quick Installation Guide or User's Manual.

2.2 Installing Hard Disk & Memory

Step 1. Memory Installation: Unfasten 6 screws from the case to take off the top chassis.

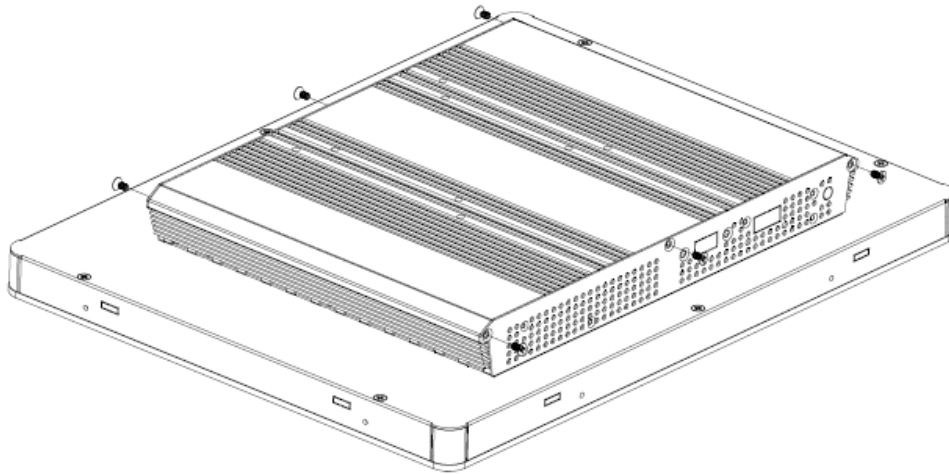

Step 2. Insert the SODIMM into the memory socket.

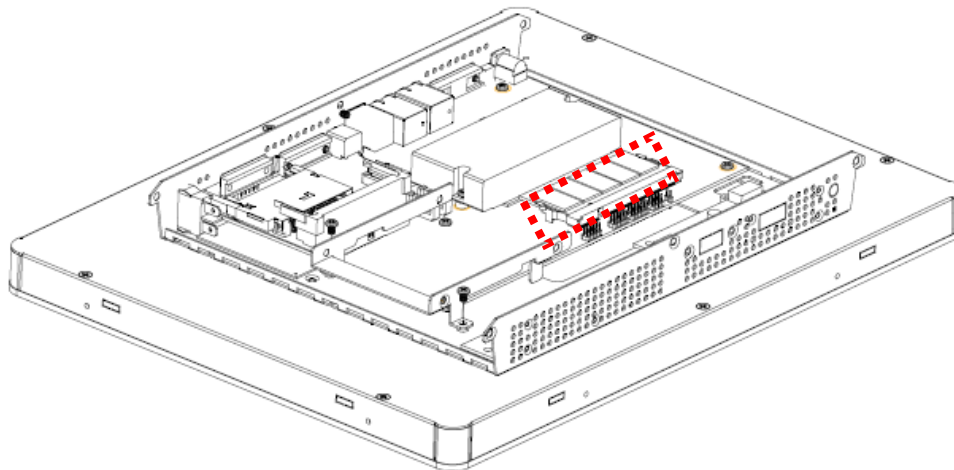

Step 3-1. HDD Installation: Unfasten 2 screws of the HDD bracket and take it off.

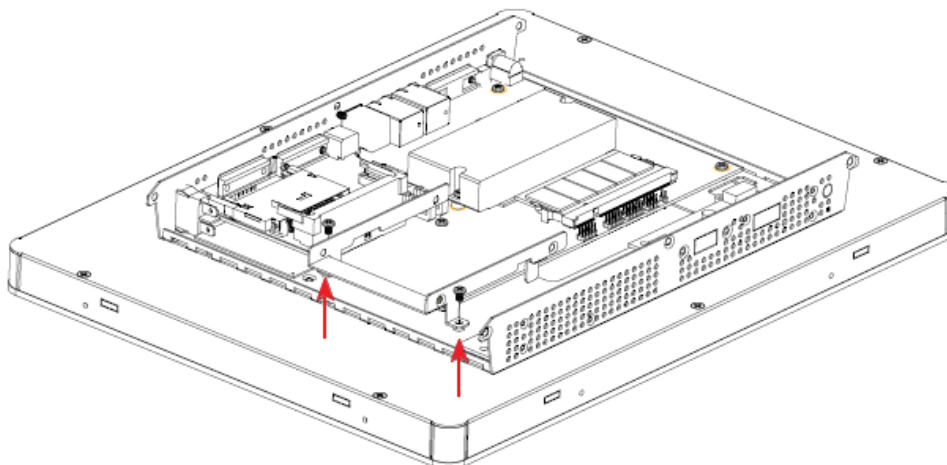

Step 3-2. Insert the HDD into the bracket and fasten 4 screws.

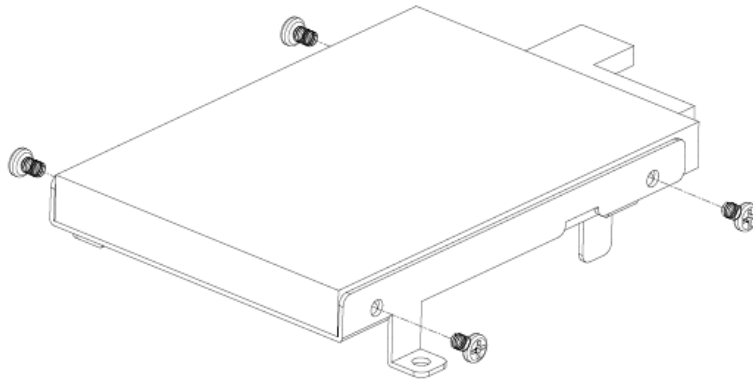

Step 3-3. Insert the cable to connect the HDD and the SATA connector.

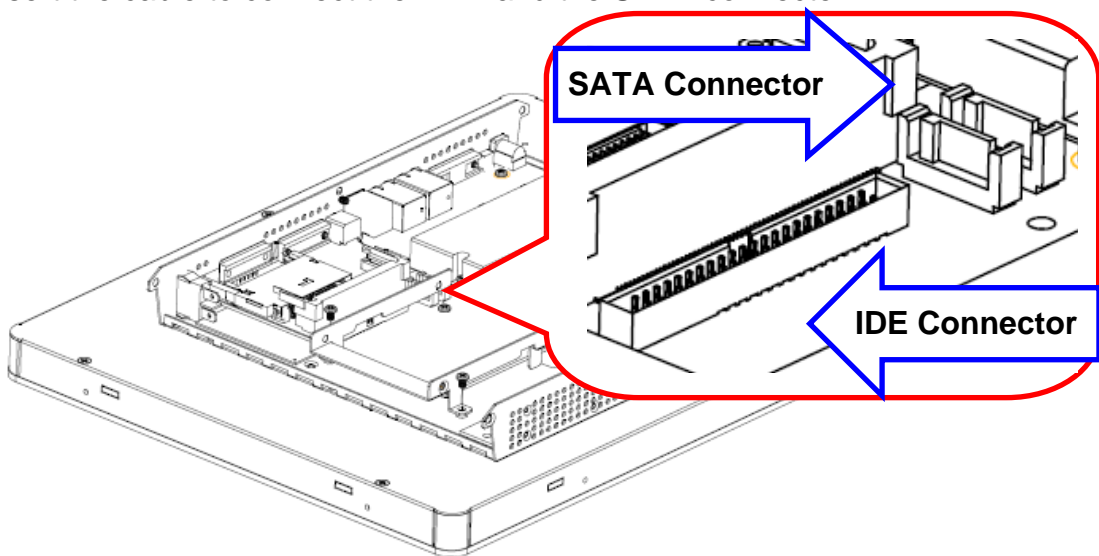

Step 3-4. SATA HDD Installation: By default, the SATA cables had been inserted to the according connectors. Just connect to SATA HDD with the two cables.

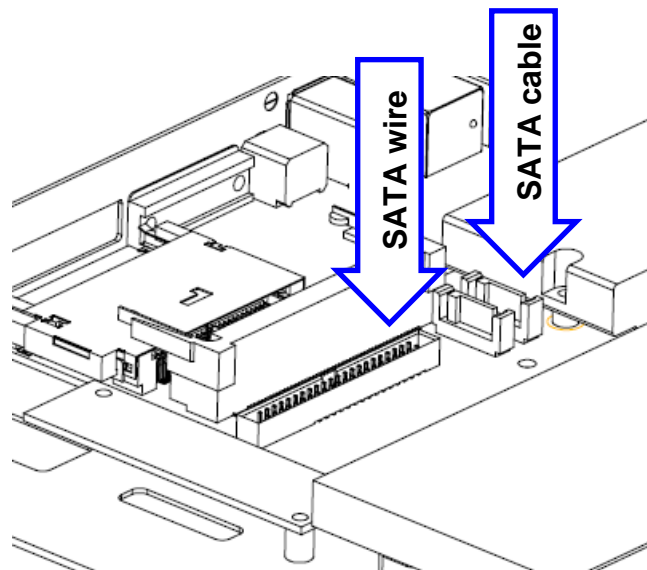

LPC 15" Series

Step 3-5. Insert the HDD back and fasten 2 screws.

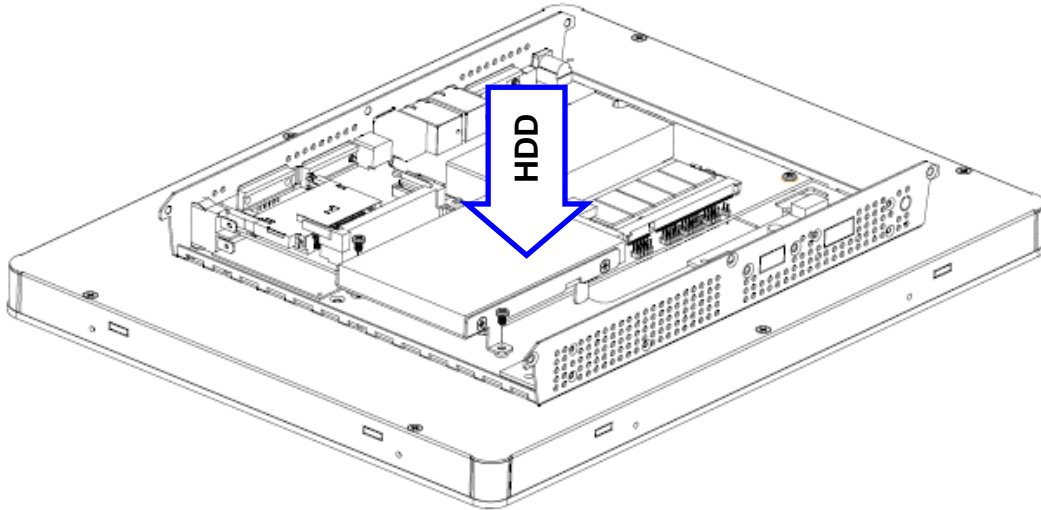

Step 4. Place back the chassis with 6 screws locked.

