

InnoDisk
Mini PCIeDOM D150

Datasheet
Preliminary

Table of contents

REVISION HISTORY	4
LIST OF TABLES	5
LIST OF FIGURES	8
1. PRODUCT OVERVIEW	9
1.1 INTRODUCTION OF INNO DISK MINI PCIE DOM D150.....	9
1.2 PRODUCT VIEW	9
1.3 PRODUCT MODELS	9
1.4 MINI PCI EXPRESS INTERFACE	9
1.5 CAPACITY	9
2. THEORY OF OPERATION	10
2.1 OVERVIEW.....	10
2.2 ERROR DETECTION AND CORRECTION	10
2.4 WEAR-LEVELING.....	10
2.5 BAD BLOCKS MANAGEMENT	11
3. INSTALLATION REQUIREMENTS	12
3.1 DEVICE DRIVER.....	12
3.2 SUPPORTED OS	12
4. SPECIFICATIONS	13
4.1 CE AND FCC COMPATIBILITY	13
4.2 ROHS COMPLIANCE	13
4.3 ENVIRONMENTAL SPECIFICATIONS	13
4.3.1 Temperature Ranges	13
4.3.2 Humidity	13
4.3.3 Shock and Vibration.....	13
4.3.4 Mean Time between Failures (MTBF)	13
4.4 ENDURANCE	14
4.6 PIN ASSIGNMENT	15
4.7 MECHANICAL DIMENSIONS.....	16
4.8 WEIGHT	16
4.9 PERFORMANCE.....	16
4.10 SEEK TIME	16
4.11 NAND FLASH MEMORY.....	16
4.12 ELECTRICAL SPECIFICATIONS	17
4.12.1 Power Requirement	17
4.12.2 Power Consumption.....	17

4.13.3 DEVICE PARAMETERS	17
5. SUPPORTED ATA COMMANDS	18
5.1 SUPPORTED ATA COMMANDS	18
5.1.1 Check Power Mode.....	19
5.1.2 IDENTIFY DEVICE	20
5.1.3 IDLE	29
5.1.4 Idle Immediate	30
5.1.5 SMART	32
5.1.6 Read Multiple.....	36
5.1.7 Read Sector(s).....	38
5.1.8 Read Verify Sector.....	40
5.1.9 Read DMA	41
5.1.10 Set Multiple Mode	43
5.1.11 Set Sleep Mode	45
5.1.12 Flush Cache.....	46
5.1.13 Standby.....	48
5.1.14 Standby Immediate	49
5.1.15 Write Multiple	51
5.1.16 Write Sector	53
5.1.17 Write DMA.....	56
5.1.18 Execute Device Diagnostic.....	58
5.1.19 Security Set Password.....	59
5.1.20 Security Unlock.....	61
5.1.21 Security Erase Prepare.....	63
5.1.22 Security Erase Unit	65
5.1.23 Security Freeze Lock	67
5.1.24 Security Disable Password	69
6. PART NUMBER RULE.....	72

REVISION HISTORY

Revision	Description	Date
Preliminary	First Released	September, 2011

List of Tables

TABLE 1: SHOCK/VIBRATION TESTING FOR INNO DISK Mini PCIeDOM D150	13
TABLE 2: INNO DISK Mini PCIeDOM D150 MTBF	14
TABLE 3: INNO DISK Mini PCIeDOM D150 PIN ASSIGNMENT	15
TABLE 4: INNO DISK Mini PCIeDOM D150 POWER REQUIREMENT	17
TABLE 5: POWER CONSUMPTION	17
TABLE 6: DEVICE PARAMETERS	17
TABLE 7: ATA COMMANDS	18
TABLE 8: CHECK POWER MODE COMMAND FOR INPUTS INFORMATION	20
TABLE 9: IDENTIFY DEVICE COMMAND FOR INPUTS INFORMATION	20
TABLE 10: IDENTIFY DEVICE COMMAND FOR NORMAL OUTPUTS INFORMATION	20
TABLE 11: IDENTIFY DEVICE COMMAND PARAMETERS	21
TABLE 12: IDLE COMMAND FOR INPUTS INFORMATION	29
TABLE 13: IDLE COMMAND SECTOR COUNT REGISTER CONTENTS INFORMATION	29
TABLE 14: IDLE COMMAND FOR NORMAL OUTPUTS INFORMATION	30
TABLE 15: IDLE COMMAND FOR ERROR OUTPUTS INFORMATION	30
TABLE 16: IDLE IMMEDIATE COMMAND FOR INPUTS INFORMATION	31
TABLE 17: IDLE IMMEDIATE COMMAND FOR NORMAL OUTPUTS INFORMATION	31
TABLE 18: SMART FEATURE REGISTER VALUES	32
TABLE 19: SMART COMMAND FOR INPUTS INFORMATION	32
TABLE 20: SMART COMMAND FOR NORMAL OUTPUTS INFORMATION	32
TABLE 21: ID OF SMART DATA STRUCTURE	33
TABLE 22: SMART COMMAND FOR AVERAGE/MAX ERASE COUNT INFORMATION	33
TABLE 23: SMART ENABLE COMMAND FOR INPUTS INFORMATION	34
TABLE 24: SMART COMMAND FOR NORMAL OUTPUTS INFORMATION	34
TABLE 25: SMART DISABLE COMMAND FOR INPUTS INFORMATION	35
TABLE 26: SMART COMMAND FOR NORMAL OUTPUTS INFORMATION	35
TABLE 27: READ MULTIPLE COMMAND FOR INPUTS INFORMATION	36
TABLE 28: READ MULTIPLE COMMAND FOR NORMAL OUTPUT INFORMATION	36
TABLE 29: READ MULTIPLE COMMAND FOR ERROR OUTPUT INFORMATION	37
TABLE 30: READ SECTOR COMMAND FOR INPUTS INFORMATION	38
TABLE 31: READ SECTOR COMMAND FOR NORMAL OUTPUTS INFORMATION	38
TABLE 32: READ SECTOR COMMAND FOR ERROR OUTPUTS INFORMATION	39
TABLE 33: READ VERIFY SECTOR COMMAND FOR INPUTS INFORMATION	40
TABLE 34: READ VERIFY SECTOR COMMAND FOR NORMAL OUTPUT INFORMATION	40
TABLE 35: READ VERIFY SECTOR COMMAND FOR NORMAL OUTPUT INFORMATION	41
TABLE 36: READ DMA COMMAND FOR INPUTS INFORMATION	42
TABLE 37: READ DMA COMMAND FOR NORMAL OUTPUT INFORMATION	42
TABLE 38: READ DMA COMMAND FOR ERROR OUTPUT INFORMATION	43
TABLE 39: SET MULTIPLE MODE COMMAND FOR INPUTS INFORMATION	44

TABLE 40: SET MULTIPLE MODE COMMAND FOR NORMAL OUTPUT INFORMATION	44
TABLE 41: SET MULTIPLE MODE COMMAND FOR ERROR OUTPUTS INFORMATION	44
TABLE 42: SET SLEEP MODE FOR INPUTS INFORMATION	45
TABLE 43: SET SLEEP MODE FOR NORMAL OUTPUT INFORMATION	45
TABLE 44: SET SLEEP MODE FOR ERROR OUTPUT INFORMATION	46
TABLE 45: FLUSH CACHE COMMAND FOR INPUTS INFORMATION	46
TABLE 46: FLUSH CACHE COMMAND FOR NORMAL OUTPUT INFORMATION	47
TABLE 47: FLUSH CACHE COMMAND FOR ERROR OUTPUT INFORMATION	47
TABLE 48: STANDBY COMMAND FOR INPUTS INFORMATION	48
TABLE 49: STANDBY COMMAND FOR NORMAL OUTPUT INFORMATION	48
TABLE 50: STANDBY COMMAND FOR ERROR OUTPUT INFORMATION	49
TABLE 51: STANDBY IMMEDIATE COMMAND FOR INPUTS INFORMATION	50
TABLE 52: STANDBY IMMEDIATE COMMAND FOR NORMAL OUTPUT INFORMATION	50
TABLE 53: STANDBY IMMEDIATE COMMAND FOR ERROR OUTPUT INFORMATION	50
TABLE 54: WRITE MULTIPLE COMMAND FOR INPUTS INFORMATION	51
TABLE 55: WRITE MULTIPLE COMMAND FOR NORMAL OUTPUT INFORMATION	52
TABLE 56: WRITE MULTIPLE COMMAND FOR NORMAL OUTPUT INFORMATION	52
TABLE 57: WRITE SECTOR COMMAND FOR INPUTS INFORMATION	54
TABLE 58: WRITE SECTOR COMMAND FOR INPUTS INFORMATION	54
TABLE 59: WRITE SECTOR COMMAND FOR ERROR OUTPUTS INFORMATION	55
TABLE 60: WRITE DMA COMMAND FOR INPUT INFORMATION	56
TABLE 61: WRITE DMA COMMAND FOR NORMAL OUTPUT INFORMATION	56
TABLE 62: WRITE DMA COMMAND FOR ERROR OUTPUTS INFORMATION	57
TABLE 63: EXECUTE DEVICE DIAGNOSTIC COMMAND FOR INPUTS INFORMATION	58
TABLE 64: EXECUTE DEVICE DIAGNOSTIC COMMAND FOR NORMAL OUTPUTS INFORMATION	58
TABLE 65: EXECUTE DEVICE DIAGNOSTIC COMMAND FOR STATUS REGISTER INFORMATION	59
TABLE 66: SECURITY SET PASSWORD COMMAND FOR INPUTS INFORMATION	59
TABLE 67: SECURITY SET PASSWORD COMMAND FOR NORMAL OUTPUTS INFORMATION	59
TABLE 68: SECURITY SET PASSWORD COMMAND FOR ERROR OUTPUTS INFORMATION	60
TABLE 69: SECURITY SET PASSWORD COMMAND'S DATA CONTENT	61
TABLE 70: SECURITY SET PASSWORD COMMAND'S IDENTIFIER AND SECURITY LEVEL BIT INTERACTION	61
TABLE 71: SECURITY UNLOCK COMMAND FOR INPUTS INFORMATION	61
TABLE 72: SECURITY UNLOCK COMMAND FOR INPUTS INFORMATION	62
TABLE 73: SECURITY UNLOCK COMMAND FOR INPUTS INFORMATION	62
TABLE 74: SECURITY ERASE PREPARE COMMAND FOR INPUTS INFORMATION	63
TABLE 75: SECURITY ERASE PREPARE COMMAND FOR NORMAL OUTPUTS INFORMATION	64
TABLE 76: SECURITY ERASE PREPARE COMMAND FOR ERROR OUTPUTS INFORMATION	64
TABLE 77: SECURITY ERASE UNIT COMMAND FOR INPUTS INFORMATION	65
TABLE 78: SECURITY ERASE UNIT COMMAND FOR NORMAL OUTPUTS INFORMATION	65
TABLE 79: SECURITY ERASE UNIT COMMAND FOR ERROR OUTPUTS INFORMATION	66
TABLE 80: SECURITY ERASE UNIT PASSWORD INFORMATION	67

TABLE 81: SECURITY FREEZE LOCK FOR INPUTS INFORMATION.....	67
TABLE 82: SECURITY FREEZE LOCK FOR NORMAL OUTPUTS INFORMATION.....	67
TABLE 83: SECURITY FREEZE LOCK FOR ERROR OUTPUTS INFORMATION.....	68
TABLE 84: SECURITY DISABLE PASSWORD COMMAND FOR INPUTS INFORMATION.....	69
TABLE 85: SECURITY DISABLE PASSWORD COMMAND FOR NORMAL OUTPUTS INFORMATION.....	69
TABLE 86: SECURITY DISABLE PASSWORD COMMAND FOR ERROR OUTPUTS INFORMATION.....	70
TABLE 87: SECURITY DISABLE PASSWORD COMMAND CONTENT.....	71

List of Figures

FIGURE 1: INNOISK MINI PCIEDOM D150.....	9
FIGURE 2: INNOISK MINI PCIEDOM D150 BLOCK DIAGRAM.....	10
FIGURE 3: INNOISK MINI PCIEDOM D150 MECHANICAL DIMENSIONS	16

1. Product Overview

1.1 Introduction of InnoDisk Mini PCIeDOM D150

PCI Express has been adopted as a mainstream interface of storage, which dramatically increases data transfer bandwidth and application performance; Besides, Mini PCI Express also been applied in most of IPC and embedded system.

InnoDisk Mini PCIeDOM D150 is a Flash disk on module with Mini PCI Express interface, which brings you new generation of storage solution, especially focused on embedded systems. It not only provide standard PCIe interface but also delivers excellent performance, which up to 135 MB/s for reading and 130 MB/s for writing.

Comparing with most Mini PCIe storage devices in the market, Mini PCIeDOM D150 comes with standard Mini PCI Express pin definition, for board maker or system integrator is the easiest way to design in this product, and just plug and play without any circuit modification.

1.2 Product View

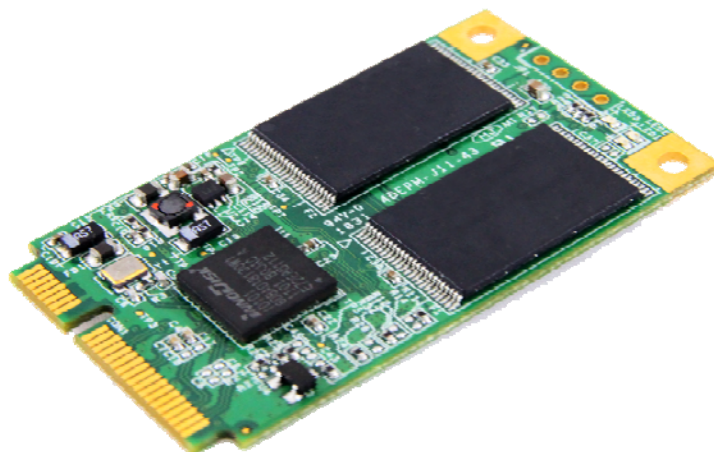

Figure 1: InnoDisk Mini PCIeDOM D150

1.3 Product Models

InnoDisk Mini PCIeDOM D150 is available in follow capacities.

Mini PCIeDOM D150 2GB	Mini PCIeDOM D150 16GB
Mini PCIeDOM D150 4GB	Mini PCIeDOM D150 32GB
Mini PCIeDOM D150 8GB	Mini PCIeDOM D150 64GB

1.4 Mini PCI Express Interface

InnoDisk Mini PCIeDOM D150 is designed with Mini PCIe form factor, and supports PCI Express Gen.1.

1.5 Capacity

InnoDisk Mini PCIeDOM D150 provides unformatted 2GB, 4GB, 8GB, 16GB 32GB, and 64GB capacities within SLC Flash IC.

2. Theory of operation

2.1 Overview

Figure 2 shows the operation of InnoDisk Mini PCIeDOM D150 from the system level, including the major hardware blocks.

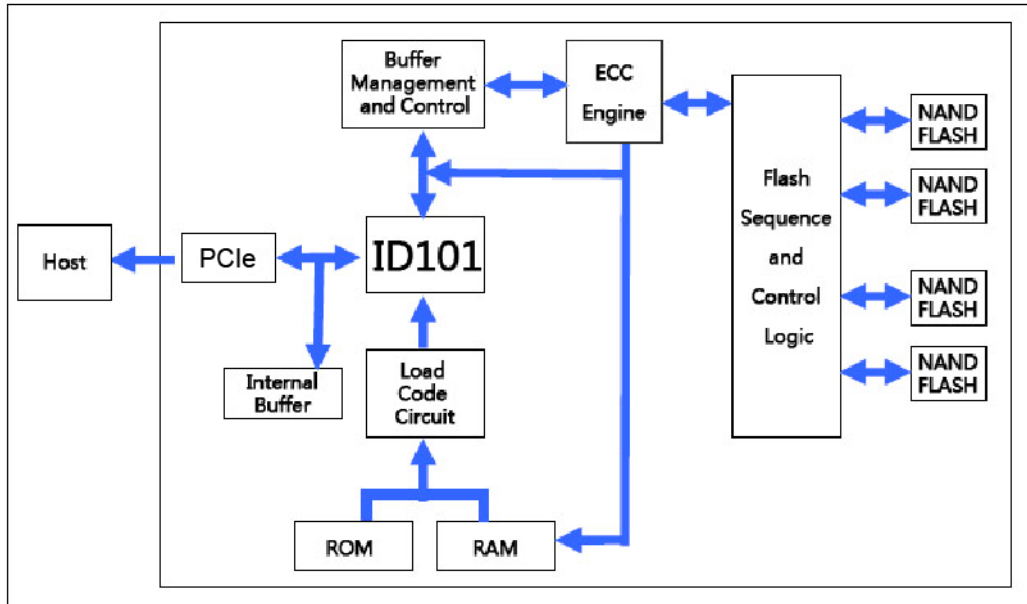

Figure 2: InnoDisk Mini PCIeDOM D150 Block Diagram

InnoDisk Mini PCIeDOM II integrates a PCI Express controller, and NAND flash memories. Communication with the host occurs through the host interface, using the standard PCI Express protocol. Communication with the flash device(s) occurs through the flash interface.

2.2 Error Detection and Correction

Highly sophisticated Error Correction Code algorithms are implemented. The ECC unit consists of the Parity Unit (parity-byte generation) and the Syndrome Unit (syndrome-byte computation). This unit implements an algorithm that can correct 24 bits per 1024 bytes in an ECC block. Code-byte generation during write operations, as well as error detection during read operation, is implemented on the fly without any speed penalties.

2.4 Wear-Leveling

Flash memory can be erased within a limited number of times. This number is called the **erase cycle limit** or **write endurance limit** and is defined by the flash array vendor. The erase cycle limit applies to each individual erase block in the flash device.

InnoDisk Mini PCIeDOM D150 uses a static wear-leveling algorithm to ensure that consecutive writes of a specific sector are not written physically to the same page/block in the flash. This spreads flash media usage evenly across all pages, thereby extending flash lifetime.

2.5 Bad Blocks Management

Bad Blocks are blocks that contain one or more invalid bits whose reliability are not guaranteed. The Bad Blocks may be presented while the SSD is shipped, or may generate during the life time of the SSD. When the Bad Blocks is detected, it will be flagged, and not be used anymore. The SSD implement Bad Blocks management and replacement, Error Correct Code to avoid data error occurred. The functions will be enabled automatically to transfer data from Bad Blocks to spare blocks, and correct error bit. After the reserved block less than 40, the SSD will be locked, and cannot be written anymore.

3. Installation Requirements

3.1 Device driver

No additional device driver is required; InnoDisk Mini PCIeDOM D150 can be configured as a boot device.

3.2 Supported OS

Windows

- Windows XP SP3
- Windows XP Embedded
- Windows 7 SP1

Linux:

- Ubuntu
- Open SUSE

(Updated: 2011/8/31)

4. Specifications

4.1 CE and FCC Compatibility

InnoDisk Mini PCIeDOM D150 conforms to CE and FCC requirements.

4.2 RoHS Compliance

InnoDisk Mini PCIeDOM D150 is fully compliant with RoHS directive.

4.3 Environmental Specifications

4.3.1 Temperature Ranges

Operating Temperature Range:

- Standard Grade: 0°C ~ +70°C

Storage Temperature Range:

- Standard Grade: -55°C to +95°C

4.3.2 Humidity

Relative Humidity: 10-95%, non-condensing

4.3.3 Shock and Vibration

Table 1: Shock/Vibration Testing for InnoDisk Mini PCIeDOM D150

Reliability	Test Conditions	Reference Standards
Vibration	7 Hz to 2K Hz, 20G, 3 axes	IEC 68-2-6
Mechanical Shock	Duration: 0.5ms, 1500G, 3 axes	IEC 68-2-27

4.3.4 Mean Time between Failures (MTBF)

Table 2 summarizes the MTBF prediction results for various InnoDisk Mini PCIeDOM D150 configurations. The analysis was performed using a RAM Commander™ failure rate prediction.

- **Failure Rate:** The total number of failures within an item population, divided by the total number of life units expended by that population, during a particular measurement interval under stated condition.
- **Mean Time between Failures (MTBF):** A basic measure of reliability for repairable items: The mean number of life units during which all parts of the item perform within their specified limits, during a particular measurement interval under stated conditions.
-

Table 2: InnoDisk Mini PCIeDOM D150 MTBF

Product	Condition	MTBF (Hours)
InnoDisk Mini PCIeDOM D150	Telcordia SR-332 GB, 25°C	>4,000,000

4.4 Endurance

Data Retention: 10 years.

Wear-Leveling Algorithm: Support.

Bad Blocks Management: Support

Error Correct Code: Support

4.6 Pin Assignment

Table 3: InnoDisk Mini PCIeDOM D150 Pin Assignment

Pin #	Signal Name	Pin #	Signal Name
51	NC	52	3.3V
49	NC	50	GND
47	NC	48	NC
45	NC	46	NC
43	GND	44	NC
41	3.3V	42	NC
39	3.3V	40	GND
37	GND	38	NC
35	GND	36	NC
33	PETp0	34	GND
31	PETn0	32	NC
29	GND	30	NC
27	GND	28	NC
25	PERp0	26	GND
23	PERn0	24	3.3V
21	GND	22	PERST#
19	NC	20	NC
17	NC	18	GND
Mechanical Key			
15	GND	16	NC
13	REFCLK+	14	NC
11	REFCLK-	12	NC
9	GND	10	NC
7	GND	8	NC
5	NC	6	NC
3	NC	4	GND
1	NC	2	3.3V

4.7 Mechanical Dimensions

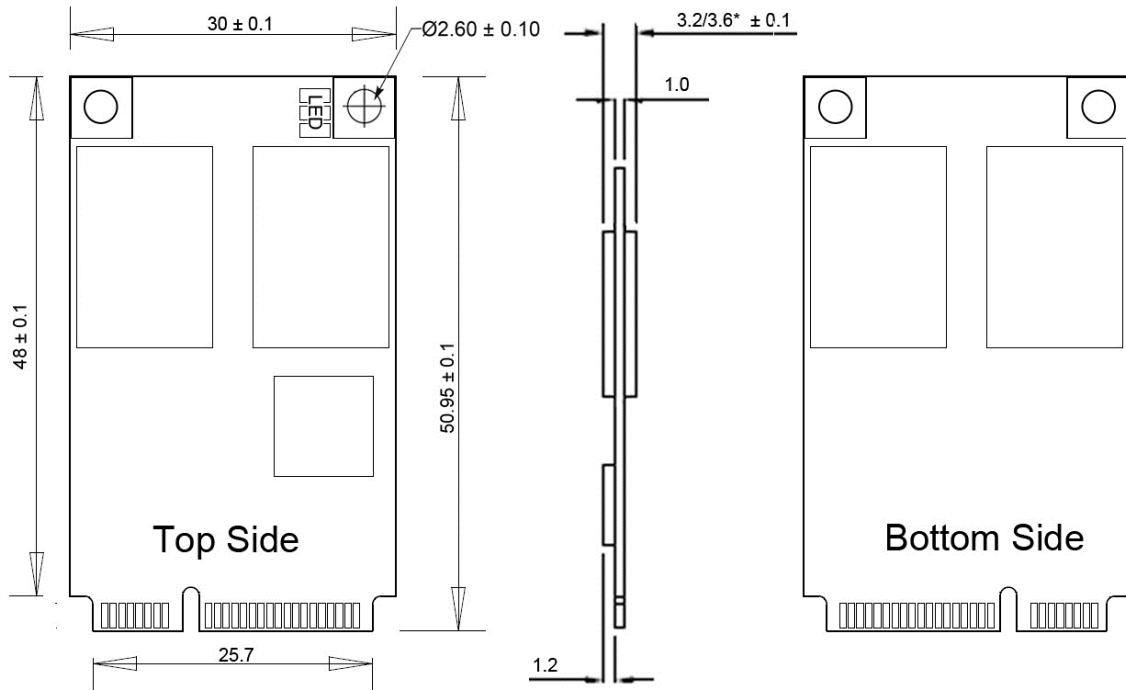

Figure 3: InnoDisk Mini PCIeDOM D150 mechanical dimensions
(* thickness would be different in different capacity)

4.8 Weight

8g±2g

4.9 Performance

64GB

Sustained Read : 137MB/sec (max.)

Sustained Write : 117MB/sec (max.)

32GB

Sustained Read : 136MB/sec (max.)

Sustained Write : 119MB/sec (max.)

16GB

Sustained Read : 135MB/sec (max.)

Sustained Write : 116MB/sec (max.)

8GB

Sustained Read : 113MB/sec (max.)

Sustained Write : 69MB/sec (max.)

4GB

Sustained Read : 60MB/sec (max.)

Sustained Write : 35MB/sec (max.)

2GB

Sustained Read : 30MB/sec (max.)

Sustained Write : 12MB/sec (max.)

4.10 Seek Time

InnoDisk Mini PCIeDOM D150 is not a magnetic rotating design. There is no seek or rotational latency required.

4.11 NAND Flash Memory

InnoDisk Mini PCIeDOM D150 uses Single Level Cell (SLC) NAND flash memory, which is non-volatility, high

reliability which has 100,000 program/erase times and high speed memory storage.

4.12 Electrical Specifications

4.12.1 Power Requirement

Table 4: InnoDisk Mini PCIeDOM D150 Power Requirement

Item	Symbol	Rating	Unit
Input voltage	V _{IN}	+3.3DC +- 5% 500mA (max.)	V

4.12.2 Power Consumption

Table 5: Power Consumption

Mode	Power Consumption
Read	230mA (max.)
Write	330mA (max.)
Idle	130mA (max.)

4.13.3 Device Parameters

InnoDisk Mini PCIeDOM D150 device parameters listed in Table 6.

Table 6: Device parameters

Capacity	Cylinders	Heads	Sectors	LBA	User capacity(MB)
2GB	3897	16	63	3928176	1918.05MB
4GB	7773	16	63	7835184	3825.77MB
8GB	15525	16	63	15649200	7641.21MB
16GB	16383	16	63	31277232	15272.09MB
32GB	16383	16	63	62533296	30533.84MB
64GB	TBD	TBD	TBD	TBD	TBD

5. Supported ATA Commands

5.1 Supported ATA Commands

InnoDisk Mini PCIeDOM D150 supports the commands listed in Table 7.

Table 7: ATA Commands

Command Name	Code	PARAMETERS USED					
		SC	SN	CY	DR	HD	FT
CHECK POWER MODE	E5h	O	X	X	O	X	X
DEVICE CONFIGURATION OVERLAY	B1h	X	X	X	O	X	O
EXECUTE DIAGNOSTICS	90h	X	X	X	O	X	X
FLUSH CACHE	E7h	X	X	X	O	X	X
FLUSH CACHE EXT	EAh	X	X	X	O	X	X
IDENTIFY DEVICE	ECh	X	X	X	O	X	X
IDLE	E3h	O	X	X	O	X	X
IDLE IMMEDIATE	E1h	X	X	X	O	X	X
NOP	00h	F	F	F	O	X	O
INITIALIZE DEVICE PARAMETERS	91h	O	X	X	O	O	X
READ BUFFER	E4h	X	X	X	O	X	X
READ DMA	C8h or C9h	O	O	O	O	O	X
READ DMA EXT	25h	O	O	O	O	O	X
READ FPDMA QUEUED	60h	O	O	O	O	O	O
READ LOG EXT	2Fh	O	O	O	O	O	O
READ MULTIPLE	C4h	O	O	O	O	O	X
READ MULTIPLE EXT	29h	O	O	O	O	O	X
READ NATIVE MAX ADDRESS	F8h	X	X	X	O	X	X
READ NATIVE MAX ADDRESS EXT	27h	X	X	X	O	X	X
READ SECTOR(S)	20h or 21h	O	O	O	O	O	X
READ SECTOR(S) EXT	24h	O	O	O	O	O	X
READ VERIFY SECTOR(S)	40h or 41h	O	O	O	O	O	X
READ VERIFY SECTOR(S) EXT	42h	O	O	O	O	O	X
RECALIBRATE	10h	X	X	X	O	X	X
SECURITY DISABLE PASSWORD	F6h	X	X	X	O	X	X
SECURITY ERASE PREPARE	F3h	X	X	X	O	X	X
SECURITY ERASE UNIT	F4h	X	X	X	O	X	X
SECURITY FREEZE LOCK	F5h	X	X	X	O	X	X
SECURITY SET PASSWORD	F1h	X	X	X	O	X	X
SECURITY UNLOCK	F2h	X	X	X	O	X	X

SEEK	7xh	X	X	O	O	O	X
SET FEATURES	EFh	O	X	X	O	X	O
SET MAX	F9h	O	O	O	O	O	O
SET MAX ADDRESS EXT	37h	O	O	O	O	O	X
SET MULTIPLE MODE	C6h	O	X	X	O	X	X
SLEEP	E6h	X	X	X	O	X	X
SMART	B0h	X	X	O	O	X	O
STANDBY	E2h	X	X	X	O	X	X
STANDBY IMMEDIATE	E0h	X	X	X	O	X	X
WRITE BUFFER	E8h	X	X	X	O	X	X
WRITE DMA	CAh or CBh	O	O	O	O	O	X
WRITE DMA EXT	35h	O	O	O	O	O	X
WRITE DMA FUA EXT	3Dh	O	O	O	O	O	X
WRITE FPDMA QUEUED	61h	O	O	O	O	O	O
WRITE LOG EXT	3Fh	O	O	O	O	O	X
WRITE MULTIPLE	C5h	O	O	O	O	O	X
WRITE MULTIPLE EXT	39h	O	O	O	O	O	X
WRITE MULTIPLE FUA EXT	CEh	O	O	O	O	O	X
WRITE SECTOR(S)	30h or 31h	O	O	O	O	O	X
WRITE SECTOR(S) EXT	34h	O	O	O	O	O	X
WRITE VERIFY	3Ch	O	O	O	O	O	O

Note:

O = Valid, X = Don't care

SC = Sector Count Register

SN = Sector Number Register

CY = Cylinder Low/High Register

DR = DEVICE SELECT Bit (DEVICE/HEAD Register Bit 4)

HD = HEAD SELECT Bit (DEVICE/HEAD Register Bit 3-0)

FT = Features Register

5.1.1 Check Power Mode

5.1.1.1 Command Code

E5h

5.1.1.2 Feature Set

Power Management feature set.

- This command is mandatory for devices.

-This command is mandatory when the Power Management feature set is implemented.

5.1.1.3 Protocol

Non-data command

5.1.1.4 Inputs

Table 8: Check power mode command for inputs information

Register	7	6	5	4	3	2	1	0
Features	Na							
Sector Count	Na							
LBA Low	Na							
LBA Mid	Na							
LBA High	Na							
Device	obs	Na	Obs	DEV	Na	Na	Na	Na
Command	E5h							

Device register

DEV shall specify the selected device.

5.1.2 IDENTIFY DEVICE

5.1.2.1 Command Code

ECh

5.1.2.2 Feature Set

General feature set

-Mandatory for all devices.

-Devices implementing the PACKET Command feature set

5.1.2.3 Protocol

PIO data-in

5.1.2.4 Inputs

Table 9: Identify device command for inputs information

Register	7	6	5	4	3	2	1	0
Features	Na							
Sector Count	Na							
LBA Low	Na							
LBA Mid	Na							
LBA High	Na							
Device	obs	Na	Obs	DEV	Na	Na	Na	Na
Command	ECh							

Device register

DEV shall specify the selected device.

5.1.2.5 Outputs

5.1.2.6 Normal outputs

Table 10: Identify device command for normal outputs information

Register	7	6	5	4	3	2	1	0
Error	Na							
Sector Count	Na							
LBA Low	Na							

LBA Mid	Na							
LBA High	Na							
Device	obs	Na	obs	DEV	Na	Na	Na	Na
Status	BSY	DRDY	DF	Na	DRQ	Na	Na	ERR

Device register

DEV shall indicate the selected device.

Status register

BSY shall be cleared to zero indicating command completion.

DRDY shall be set to one.

DF (Device Fault) shall be cleared to zero.

DRQ shall be cleared to zero.

ERR shall be cleared to zero.

5.1.2.7 Prerequisites

DRDY set to one.

5.1.2.8 Description

The IDENTIFY DEVICE command enables the host to receive parameter information from the device. When the command is issued, the device sets the BSY bit to one, prepares to transfer the 256 words of device identification data to the host, sets the DRQ bit to one, clears the BSY bit to zero, and asserts INTRQ if nIEN is cleared to zero. The host may then transfer the data by reading the Data register. Table 8 defines the arrangement and meaning of the parameter words in the buffer. All reserved bits or words shall be zero.

Some parameters are defined as a 16-bit value. A word that is defined as a 16-bit value places the most significant bit of the value on signal line DD15 and the least significant bit on signal line DD0.

Some parameters are defined as 32-bit values (e.g. words (61:60)). Such fields are transfer using two successive word transfers. The device will first transfer the least significant bits, bits (15:0) of the value, on signal lines DD(15:0) respectively. After the least significant bits have been transferred, the most significant bits, bits(31:16) of the value, shall be transferred on DD(15:0) respectively.

Some parameters are defined as a string of ASCII characters.

Table 11: Identify device command parameters

Word	Value	F/V	Description
0	0040h	F	General configuration
		X	15 0 = ATA device
		X	14-8 Retired
		X	7-6 Obsolete
		X	5-3 Retired
		V	2 Response incomplete
		X	1 Retired
		0	Reserved
1	XXXXh	F	Number of logical cylinders
2	C837h	V	Specific configuration
3	0010h	F	Number of logical heads
4-5	0000h	X	Retired
6	003Fh	F	Number of logical sector per logical track

7-8	0000h		Reserved for assignment by the CompactFlash_ Association
9	0000h	X	Retired
10-19	XXXXh	F	Serial number (20 ASCII characters)
20-21	0000h	X	Retired
22	0000h	X	Obsolete
23-26	XXXXh	F	Firmware revision (8 ASCII characters)
27-46	XXXXh	F	Model number (40 ASCII characters)
47	8010h	F F	15-8 80h 7-0 00h = Reserved 01h = Maximum number of 1 sectors on READ/WRITE MULTIPLE commands
48	0000h		Reserved
49	2F00h	F F F F F X	Capabilities 15-14 Reserved for the IDENTIFY PACKET DEVICE command. 13 1 = Standby timer values as specified in this standard are supported 0 = Standby timer values shall be managed by the device 12 Reserved for the IDENTIFY PACKET DEVICE command. 11 1 = IORDY supported 0 = IORDY may be supported 10 1 = IORDY may be disabled 9 1 = LBA supported 8 1 = DMA supported. 7-0 Retired
50	4000h	F F X F	Capabilities 15 Shall be cleared to zero. 14 Shall be set to one. 13-2 Reserved. 1 Obsolete 0 Shall be set to one to indicate a device specific Standby timer value minimum.
51	0000h	F	15-8 PIO data transfer cycle timing mode 7-0 Reserved
52	0000h	X	Obsolete
53	0007h	F F F X	15-3 Reserved 2 1 = the fields reported in word 88 are valid 0 = the fields reported in word 88 are not valid 1 1 = the fields reported in words 70:64 are valid 0 = the fields reported in words 70:64 are not valid 0 1 = the fields reported in words 58:54 are valid 0 = the fields reported in words 58:54 are not valid
54	XXXXh	X	Number of current cylinders
55	0010h	X	Number of current heads
56	003Fh	X	Number of current sector per track
57-58	XXXXh	X	Current capacity in sectors
59	0110h	V V	15-9 Reserved 8 1 = Multiple sector setting is valid 7-0 xxh = Setting for number of sectors that shall be transferred per interrupt on R/W Multiple command
60-61	XXXXh	F	Total number of user addressable sectors
62	0000h	X	Obsolete
63	0X07h		15-11 Reserved

		V	10	1 = Multiword DMA mode 2 is selected 0 = Multiword DMA mode 2 is not selected
		V	9	1 = Multiword DMA mode 1 is selected 0 = Multiword DMA mode 1 is not selected
		V	8	1 = Multiword DMA mode 0 is selected 0 = Multiword DMA mode 0 is not selected
			7-3	Reserved
		F	2	1 = Multiword DMA mode 2 and below are supported
		F	1	1 = Multiword DMA mode 1 and below are supported
		F	0	1 = Multiword DMA mode 0 is supported
64	0003h	F	15-8 7-0	Reserved Advanced PIO modes supported
65	0078h	F		Minimum Multiword DMA transfer cycle time per word
66	0078h	F		Manufacturer's recommended Multiword DMA transfer cycle time
67	0078h	F		Minimum PIO transfer cycle time without flow control
68	0078h	F		Minimum PIO transfer cycle time with IORDY flow control
69-70	0000h			Reserved
71-74	0000h			Reserved for the IDENTIFY PACKET DEVICE command
75	001Fh	F	15-5 4-0	Queue depth Reserved Maximum queue depth - 1
76	0106h	F	15-11 10 9 8 7-3 2 1 0	Serial ATA Capabilities Reserved for Serial ATA 1 = Supports Phy Event Counts 1 = Supports receipt of host initiated power management requests 1 = Supports the NCQ feature set Reserved for Serial ATA 1 = Supports SATA Gen2 Signaling Speed (3.0Gb/s) 1 = Supports SATA Gen1 Signaling Speed (1.5Gb/s) Shall be cleared to zero
77	0000h			Reserved for Serial ATA
78	0044h	F	15-7 6 5 4 3 2 1 0	Serial ATA feature supported Reserved for Serial ATA 1 = Device supports Software Settings Preservation Reserved for Serial ATA 1 = Device supports in-order data delivery 1 = Device supports initiating power management 1 = Device supports DMA Setup auto-activation 1 = Device supports non-zero buffer offsets Shall be cleared to zero
79	0040h	V	15-7 6 5 4 3 2 1 0	Serial ATA feature enabled Reserved for Serial ATA 1 = Software Settings Preservation enabled Reserved for Serial ATA 1 = In-order data delivery enabled 1 = Device initiated power management enabled 1 = DMA Setup auto-activation enabled 1 = Non-zero buffer offsets enabled Shall be cleared to zero
80	01F0h	F	15 14 13 12 11 10 9	Major version number 0000h or FFFFh = device does not report version Reserved Reserved for ATA/ATAPI-14 Reserved for ATA/ATAPI-13 Reserved for ATA/ATAPI-12 Reserved for ATA/ATAPI-11 Reserved for ATA/ATAPI-10 Reserved for ATA/ATAPI-9

		F	8	Reserved for ATA/ATAPI-8
		F	7	1 = supports ATA/ATAPI-7
		F	6	1 = supports ATA/ATAPI-6
		F	5	1 = supports ATA/ATAPI-5
		F	4	1 = supports ATA/ATAPI-4
		F	3	Obsolete
		X	2	Obsolete
		X	1	Obsolete
			0	Reserved
81	0000h	F		Minor version number
82	746Bh	X	15	Command and feature sets supported Obsolete
		F	14	1 = NOP command supported
		F	13	1 = READ BUFFER command supported
		F	12	1 = WRITE BUFFER command supported
		X	11	Obsolete
		F	10	1 = Host Protected Area feature set supported
		F	9	1 = DEVICE RESET command supported
		F	8	1 = SERVICE interrupt supported
		F	7	1 = release interrupt supported
		F	6	1 = look-ahead supported
		F	5	1 = write cache supported
		F	4	Shall be cleared to zero to indicate that the PACKET Command feature set is not supported.
		F	3	1 = mandatory Power Management feature set supported
		F	2	1 = Removable Media feature set supported
		F	1	1 = Security Mode feature set supported
			0	1 = SMART feature set supported
83	7D08h	F	15	Command and feature sets supported Shall be cleared to zero
		F	14	Shall be set to one
		F	13	1 = The FLUSH CACHE EXT command is supported
		F	12	Shall be set to one to indicate that the mandatory FLUSH CACHE command is supported
		F	11	1 = The DCO feature set is supported
		F	10	1 = The 48-bit Address feature set is supported
		F	9	1 = The AAM feature set is supported
			8	1 = SET MAX security extension supported
		F	7	Reserved
		F	6	1 = SET FEATURES subcommand required to spinup after power-up
		F	5	1 = Power-Up In Standby feature set supported
		F	4	1 = Removable Media Status Notification feature set supported
		F	3	1 = Advanced Power Management feature set supported
		F	2	1 = CFA feature set supported
			1	1 = READ/WRITE DMA QUEUED supported
			0	1 = DOWNLOAD MICROCODE command supported

84	4040h	F	15	Shall be cleared to zero
		F	14	Shall be set to one
		F	13	1 = The IDLE IMMEDIATE command with UNLOAD feature is supported
		X	12-11	Reserved for TLC
		F	10-9	Obsolete
		F	8	1 = The 64-bit World wide name is supported
		F	7	1 = The WRITE DMA QUEUED FUA EXT command is supported
		F	6	1 = The WRITE DMA FUA EXT and WRITE MULTIPLE FUA EXT commands are supported
		F	5	1 = The GPL feature set is supported
		F	4	1 = The Streaming feature set is supported
		F	3	1 = The Media Card Pass Through Command feature set is supported
		F	2	1 = Media serial number is supported
			1	1 = SMART self-test supported
	0	1 = SMART error logging supported		
85	746Xh			Command and feature sets supported or enable
		X	15	Obsolete
		F	14	1 = The NOP command is supported
		F	13	1 = The READ BUFFER command is supported
		F	12	1 = The WRITE BUFFER command is supported
		X	11	Obsolete
		V	10	1 = HPA feature set is supported
		F	9	Shall be cleared to zero to indicate that the DEVICE RESET command is not supported
		V	8	1 = The SERVICE interrupt is enabled
		V	7	1 = The release interrupt is enabled
		V	6	1 = Read look-ahead is enabled
		F	5	1 = The volatile write cache is enabled
		F	4	Shall be cleared to zero to indicate that the PACKET Command feature set is not supported.
V	3	Shall be set to one to indicate that the mandatory Power Management feature is supported		
V	2	Obsolete		
	1	1 = The Security feature set is enabled		
	0	1 = The SMART feature set is enabled		
86	BC00h			Command and feature sets supported or enable
		F	15	1 = Words 119-120 are valid
			14	Reserved
		F	13	1 = FLUSH CACHE EXT command supported
		F	12	1 = FLUSH CACHE command supported
		F	11	1 = The DCO feature set is supported
		F	10	1 = The 48-bit Address feature set is supported
		V	9	1 = The AAM feature set is enable
		V	8	1 = The SET MAX security extension is enabled by SET MAX SET PASSWORD
		F	7	Reserved for Address Offset Reserved Area Boot Method
		V	6	1 = SET FEATURES subcommand required to spin-up after power-up
		X	5	1 = The PUIS feature set is enabled
		F	4	Obsolete
F	3	1 = The APM feature set is enabled		
F	2	1 = The CFA feature set is supported		
	1	1 = The TCQ feature set is supported		
	0	1 = The DOWNLOAD MICROCODE command is supported		
87	4040h			Command and feature sets supported or enabled
		F	15	Shall be cleared to zero
		F	14	Shall be set to one
		F	13	1 = The IDLE IMMEDIATE command with UNLOAD feature is supported

		X	12-11	Reserved for TLC
		F	10-9	Obsolete
		F	8	1 = The 64-bit World wide name is supported
		F	7	1 = The WRITE DMA QUEUED FUA EXT command is supported
		F	6	1 = The WRITE DMA FUA EXT and WRITE MULTIPLE FUA EXT commands are supported
		V	5	1 = The GPL feature set is supported
		V	4	Obsolete
		F	3	1 = The Media Card Pass Through Command feature set is supported
		F	2	1 = Media serial number is supported
		F	1	1 = SMART self-test supported
		F	0	1 = SMART error logging supported
88	XX7Fh			Ultra DMA modes
			15	Reserved
		V	14	1 = Ultra DMA mode 6 is selected 0 = Ultra DMA mode 6 is not selected
		V	13	1 = Ultra DMA mode 5 is selected 0 = Ultra DMA mode 5 is not selected
		V	12	1 = Ultra DMA mode 4 is selected 0 = Ultra DMA mode 4 is not selected
		V	11	1 = Ultra DMA mode 3 is selected 0 = Ultra DMA mode 3 is not selected
		V	10	1 = Ultra DMA mode 2 is selected 0 = Ultra DMA mode 2 is not selected
		V	9	1 = Ultra DMA mode 1 is selected 0 = Ultra DMA mode 1 is not selected
		V	8	1 = Ultra DMA mode 0 is selected 0 = Ultra DMA mode 0 is not selected
			7	Reserved
		F	6	1 = Ultra DMA mode 6 and below are supported
		F	5	1 = Ultra DMA mode 5 and below are supported
		F	4	1 = Ultra DMA mode 4 and below are supported
		F	3	1 = Ultra DMA mode 3 and below are supported
		F	2	1 = Ultra DMA mode 2 and below are supported
		F	1	1 = Ultra DMA mode 1 and below are supported
		F	0	1 = Ultra DMA mode 0 is supported
89	001Eh	F	15-8	Reserved
		F	7-0	Time required for Normal Erase mode SECURITY ERASE UNIT command
90	001Eh	F	15-8	Reserved
		F	7-0	Time required for Enhanced Erase mode SECURITY ERASE UNIT command
91	0000h	V		Current APM level value
92	FFFEh	V		Master Password Identifier
93	0000h	X		Hardware reset result
94	0000h	F		Current AAM value
		F	15-8	Vendor's recommended AAM value
		V	7-0	Current AAM value
95-99	0000h			Reserved
100-103	XXXXh	X		Total Number of User Addressable Logical Sectors for 48-bit commands (QWord)
104-105	0000h			Reserved
106	4000h			Physical sector size / logical sector size
		F	15	Shall be cleared to zero
		F	14	Shall be set to one
		F	13	1 = Device has multiple logical sectors per physical sector
		F	12	1 = Device Logical Sector longer than 256 Words

		F	11-4 3-0	Reserved 2x logical sectors per physical sector
107	0000h	F		Inter-seek delay for ISO 7779 standard acoustic testig
108-111	XXXXh	F		Worldwide name
112-115	0000h			Reserved
116	0000h			Reserved for TLC
117-118	0000h	F		Logical sector size (DWord)
119	4000h	F F F F F F F	15 14 13-6 5 4 3 2 1 0	Commands and feature sets supported (Continued from words 84:82) Shall be cleared to zero Shall be set to one Reserved 1= The Free-fall Control feature set is supported 1 = The DOWNLOAD MICROCODE command with mode 3 is supported 1 = The READ LOG DMA EXT and WRITE LOG DMA EXT commands are supported 1 = The WRITE UNCORRECTABLE EXT command is supported 1 = The Write-Read-Verify feature set is supported Reserved for DDT
120	4000h	F F V F F F V	15 14 13-6 5 4 3 2 1 0	Commands and feature sets supported or enabled (Continued from words 87:85) Shall be cleared to zero Shall be set to one Reserved 1= The Free-fall Control feature set is enabled 1 = The DOWNLOAD MICROCODE command with mode 3 is supported 1 = The READ LOG DMA EXT and WRITE LOG DMA EXT commands are supported 1 = The WRITE UNCORRECTABLE EXT command is supported 1 = The Write-Read-Verify feature set is enabled Reserved for DDT
121-126	0000h			Reserved for expended supported and enabled settings
127	0000h	X		Obsolete
128	0021h	V F V V V V F	15-9 8 7-6 5 4 3 2 1 0	Security status Reserved Security level 0 = High, 1 = Maximum Reserved 1 = Enhanced security erase supported 1 = Security count expired 1 = Security frozen 1 = Security locked 1 = Security enabled 1 = Security supported
129-159	0000h	X		Vendor specific
160	0000h	F F V F	15 14 13 12 11:0	CFA power mode Word 160 supported Reserved CFA power mode 1 is required for one or more commands implemented by the device CFA power mode 1 disabled Maximum current in ma
161-167	0000h			Reserved for the Compact Flash Association
168	0003h	F	15:4 3:0	Reserved Device Nominal Form Factor

169	0000h		DATA SET MANAGEMENT is supported
		F	15:1 Reserved 0 1 = the Trim bit in the DATA SET MANAGEMENT is supported
170-173	0000h	F	Additional Product Identifier (ATA String)
174-175	0000h		Reserved
176-205	0000h	V	Current media serial number (ATA String)
206	0000h	X	SCT Command Transport
		F	15:12 Vendor Specific 11:6 Reserved 5 The SCT Data Tables command is supported 4 The SCT Feature Control command is supported 3 The SCT Error Recovery Control command is supported 2 The SCT Write Same command is supported 1 Obsolete 0 The SCT Command Transport is supported
207-208	0000h		Reserved for CE-ATA
209	4000h		Alignment of logical blocks within a physical block
		F	15 Shall be cleared to zero 14 Shall be set to one 13:0 Logical sector offset within the first physical sector where the first logical sector is placed
210-211	0000h	V	Write-Read-Verify Sector Count Mode 3 (DWord)
212-213	0000h	F	Write-Read-Verify Sector Count Mode 2 (DWord)
214	0000h		NV Cache Capabilities
		F	15:12 NC+V Cache feature set version
		F	11:8 NV Cache Power Mode feature set version
		V	7:5 Reserved 4 1 = NV Cache feature set enabled 3:2 Reserved 1 1 = NV Cache Power Mode feature set enabled 0 1 = NV Cache Power Mode feature set supported
215-216	0000h	V	NV Cache Size in Logical Blocks (DWord)
217	0001h	F	Nominal media rotation rate
218	0000h		Reserved
219	0000h	F	NV Cache Options
			15:8 Reserved 7:0 Device Estimated Time to Spin Up in Seconds
220	0000h	V	15:8 Reserved 7:0 Write-Read-Verify feature set current mode
221	0000h		Reserved
222	101Fh		Transport major version number
		F	0000h or FFFFh = device does not report version 15:12 Transport Type 0h = Parallel 1h = Serial 2h-Fh = Reserved
			Parallel Serial
		F	11:5 Reserved Reserved
		F	4 Reserved SATA Rev 2.6
		F	3 Reserved SATA Rev 2.5
		F	2 Reserved SATA II: Extensions
		F	1 ATA/ATAPI-7 SATA 1.0a
		F	0 ATA8-APT ATA8-AST
223	0000h	F	Transport minor version number

224-233	0000h		Reserved for CE-ATA
234	0000h	F	Minimum number of 512-byte data blocks per DOWNLOAD MICROCODE command for mode 3
235	0000h	F	Maximum number of 512-byte data blocks per DOWNLOAD MICROCODE command for mode 3
236-254	0000h		Reserved
255	XXXXh	V V	Integrity word 15-8 Checksum 7-0 Checksum Validity Indicator

Key:

F/V – Fixed/variable content

F = the content of the word is fixed and does not change. For removable media devices, these values may change when media is removed or changed.

V = the contents of the word is variable and may change depending on the state of the device or the commands executed by the device.

X = the content of the word may be fixed or variable.

5.1.3 IDLE

5.1.3.1.1 Command Code

E3h

5.1.3.1.2 Feature Set

Power Management Feature Set.

5.1.3.1.3 Protocol

Non-Data

5.1.3.1.4 Inputs

Values other than zero in the Sector Count register when the IDLE command is issued shall determine the time period programmed into the Standby timer.

Table 12: Idle command for inputs information

Register	7	6	5	4	3	2	1	0
Features	Na							
Sector Count	Timer period value							
LBA Low	Na							
LBA Mid	Na							
LBA High	Na							
Device	Obs	Na	Obs	DEV	Na	Na	Na	Na
Command	E3h							

Device register-

DEV shall specify the selected device.

Table 13: Idle command sector count register contents information

Sector Count register contents	Corresponding timeout period
0 (00h)	Timeout disabled
1-240 (01h-F0h)	(value*5)s
241-251 (F1h-FBh)	((Value-240)*30)min
252 (FCh)	21min
253 (FDh)	Period between 8 and 12 hrs

254 (FEh)	Reserved
255 (FFh)	21 min 15 s
NOTE – Times are approximate	

5.1.3.1.5 Normal Outputs

Table 14: Idle command for normal outputs information

Register	7	6	5	4	3	2	1	0
Error	Na							
Sector Count	Na							
LBA Low	Na							
LBA Mid	Na							
LBA High	Na							
Device	obs	Na	obs	DEV	Na	Na	Na	Na
Status	BSY	DRDY	DF	Na	DRQ	Na	Na	ERR

Device Register-

DEV shall indicate the selected device.

Status register-

BSY will be cleared to zero indicating command completion.

DRDY will be set to one.

DF (Device Fault) will be cleared to zero.

DRQ shall be cleared to zero.

ERR shall be cleared to zero.

5.1.3.1.6 Error Outputs

Table 15: Idle command for error outputs information

Register	7	6	5	4	3	2	1	0
Error	Na	Na	Na	Na	Na	ABRT	Na	Na
Sector Count	Na							
LBA Low	Na							
LBA Mid	Na							
LBA High	Na							
Device	obs	Na	obs	DEV	Na			
Status	BSY	DRDY	DF	Na	DRQ	Na	Na	ERR

5.1.3.1.7 Prerequisites

DRDY set to one

5.1.3.1.8 Description

The IDLE command allows the host to place the device in the idle mode and also set the Standby timer.

5.1.4 Idle Immediate

5.1.4.1.1 Command Code

E1h

5.1.4.1.2 Feature Set

Power Management Feature Set.

5.1.4.1.3 Protocol

Non-Data

5.1.4.1.4 Inputs

Table 16: Idle immediate command for inputs information

Register	7	6	5	4	3	2	1	0
Features	Na							
Sector Count	Na							
LBA Low	Na							
LBA Mid	Na							
LBA High	Na							
Device	obs	Na	obs	DEV	Na	Na	Na	Na
Command	E1h							

Device register-

DEV shall specify the selected device.

5.1.4.1.5 Normal Outputs

Table 17: Idle immediate command for normal outputs information

Register	7	6	5	4	3	2	1	0
Error	Na							
Sector Count	Na							
LBA Low	Na							
LBA Mid	Na							
LBA High	Na							
Device	obs	Na	obs	DEV	Na	Na	Na	Na
Status	BSY	DRDY	DF	Na	DRQ	Na	Na	ERR

Device Register-

DEV shall indicate the selected device.

Status register-

BSY will be cleared to zero indicating command completion.

DRDY will be set to one.

DF (Device Fault) will be cleared to zero.

DRQ shall be cleared to zero.

ERR shall be cleared to zero.

5.1.4.2 Prerequisites

DRDY set to one

5.1.4.3 Description

The IDLE IMMEDIATE command allows the host to immediately place the device in the idle mode.

5.1.5 SMART

Individual SMART commands are identified by the value placed in the Feature register.

Table 18: SMART Feature register values

Value	Command
D0h	SMATR Read Data
D8h	SMART ENABLE OPERATIONS
D9h	SMART DISABLE OPERATIONS

5.1.5.1 SMART Read Data

5.1.5.1.1 Command Code

B0h with a Feature register value of D0h

5.1.5.1.2 Feature Set

Smart Feature Set

- Operation when the SMART feature set is implemented.

5.1.5.1.3 Protocol

PIO data-in

5.1.5.1.4 Inputs

Table 19: SMART command for inputs information

Register	7	6	5	4	3	2	1	0
Features	D0h							
Sector Count	Na							
LBA Low	Na							
LBA Mid	4Fh							
LBA High	C2h							
Device	Obs	Na	obs	DEV	Na	Na	Na	Na
Command	B0h							

Device register-

DEV shall specify the selected device.

5.1.5.1.5 Normal Outputs

Table 20: SMART command for normal outputs information

Register	7	6	5	4	3	2	1	0
Error	Na							
Sector Count	Na							
LBA Low	Na							
LBA Mid	Na							
LBA High	Na							
Device	Obs	Na	obs	DEV	Na	Na	Na	Na
Status	BSY	DRDY	DF	Na	DRQ	Na	Na	ERR

Device Register-

DEV shall indicate the selected device.

Status register-

BSY will be cleared to zero indicating command completion.

DRDY will be set to one.

DF (Device Fault) will be cleared to zero.

DRQ shall be cleared to zero.

ERR shall be cleared to zero.

5.1.5.1.6 Prerequisites

DRDY set to one. SMART enabled.

5.1.5.1.7 Description

This command returns the Device SMART data structure to the host.

Table 21: ID of SMART data structure

	+0	+1	+2	+3	+4	+5	+6	+7	+8	+9	+10	+11
Attribute Name	ID	Flags		Init	Worst	Raw Attribute Value						Rsv
Read Error Rate	01h	0Bh	00h	64h	64h	FFh	FFh	FFh	00h	00h	00h	00h
Throughput Performance	02h	05h	00h	64h	64h	00h	00h	00h	00h	00h	00h	00h
Spin Up Time	03h	07h	00h	64h	64h	00h	00h	00h	00h	00h	00h	00h
Reallocated Sector Count	05h	13h	00h	64h	64h	00h	00h	00h	00h	00h	00h	00h
Seek Error Rate	07h	0Bh	00h	64h	64h	00h	00h	00h	00h	00h	00h	00h
Seek Time performance	08h	05h	00h	64h	64h	00h	00h	00h	00h	00h	00h	00h
Power-On hours Count	09h	12h	00h	64h	64h	(1)		00h	00h	00h	00h	00h
Spin Retry Count	0Ah	13h	00h	64h	64h	00h	00h	00h	00h	00h	00h	00h
Drive Power Cycle Count	0Ch	12h	00h	64h	64h	(2)		00h	00h	00h	00h	00h
SATA PHY Error Count	A8h	12h	00h	64h	64h	(3)		00h	00h	00h	00h	00h
Bad Block Count	AAh	03h	00h	64h	64h	00h	00h	(4)		(5)		00h
Erase Count	ADh	12h	00h	64h	64h	(6)		(7)		(6)	(7)	00h
Bad Cluster Table Count	AFh	03h	00h	64h	64h	(8)		00h	00h	00h	00h	00h
Unexpected Power Loss Count	C0h	12h	00h	64h	64h	(9)		00h	00h	00h	00h	00h
Temperature	C2h	22h	00h	(10)	64h	(10)	00h	(11)	00h	(12)	00h	00h
Current Pending Sector Counter	C5h	12h	00h	64h	64h	00h	00h	00h	00h	00h	00h	00h
Write Head	F0h	13h	00h	64h	64h	00h	00h	00h	00h	00h	00h	00h

Table 22: Smart command for average/max erase count information

	SMART	DI 101
	F: Fixed V: Variable X: None	
Byte	F/V	Description
0-188	X	
189-190	F	Total Bad Block Number of System(190:MSB 189:LSB)
191-192	F	Later Bad Block Number of System(192:MSB 191:LSB)
193-198	X	
199-200.203	F	Average Erase Count(203:MSB 199:LSB)
201-202.204	V	Maximum Erase Count(204:MSB 201:LSB)
205-510	X	
511	V	Check Sum

When the Maximum erase count is 255 bigger than average erase count, the wear-leveling will be executed.

5.1.5.2 SMART ENABLE OPERATIONS

5.1.5.2.1 Command Code

B0h with a Feature register value of D8h

5.1.5.2.2 Feature Set

Smart Feature Set

5.1.5.2.3 Protocol

Non-data

5.1.5.2.4 Inputs

Table 23: SMART Enable command for inputs information

Register	7	6	5	4	3	2	1	0
Features	D8h							
Sector Count	Na							
LBA Low	Na							
LBA Mid	4Fh							
LBA High	C2h							
Device	Obs	Na	obs	DEV	Na	Na	Na	Na
Command	B0h							

Device register-

DEV shall specify the selected device.

5.1.5.2.5 Normal Outputs

Table 24: SMART command for normal outputs information

Register	7	6	5	4	3	2	1	0
Error	Na							
Sector Count	Na							
LBA Low	Na							
LBA Mid	Na							
LBA High	Na							
Device	Obs	Na	obs	DEV	Na	Na	Na	Na
Status	BSY	DRDY	DF	Na	DRQ	Na	Na	ERR

Device Register-

DEV shall indicate the selected device.

Status register-

BSY will be cleared to zero indicating command completion.

DRDY will be set to one.

DF (Device Fault) will be cleared to zero.

DRQ shall be cleared to zero.

ERR shall be cleared to zero.

5.1.5.2.6 Prerequisites

DRDY set to one.

5.1.5.2.7 Description

This command enables access to all SMART capabilities within device.

5.1.5.3 SMART DISABLE OPERATIONS

5.1.5.3.1 Command Code

B0h with a Feature register value of D9h

5.1.5.3.2 Feature Set

Smart Feature Set

5.1.5.3.3 Protocol

Non-data

5.1.5.3.4 Inputs

Table 25: SMART DISABLE Command for inputs information

Register	7	6	5	4	3	2	1	0
Features	D9h							
Sector Count	Na							
LBA Low	Na							
LBA Mid	4Fh							
LBA High	C2h							
Device	Obs	Na	obs	DEV	Na	Na	Na	Na
Command	B0h							

Device register-

DEV shall specify the selected device.

5.1.5.3.5 Normal Outputs

Table 26: SMART command for normal outputs information

Register	7	6	5	4	3	2	1	0
Error	Na							
Sector Count	Na							
LBA Low	Na							
LBA Mid	Na							
LBA High	Na							
Device	Obs	Na	obs	DEV	Na	Na	Na	Na
Status	BSY	DRDY	DF	Na	DRQ	Na	Na	ERR

Device Register-

DEV shall indicate the selected device.

Status register-

BSY will be cleared to zero indicating command completion.

DRDY will be set to one.

DF (Device Fault) will be cleared to zero.

DRQ shall be cleared to zero.

ERR shall be cleared to zero.

5.1.5.3.6 Prerequisites

DRDY set to one. SMART enabled.

5.1.5.3.7 Description

This command disables all SMART capabilities within device.

5.1.6 Read Multiple

5.1.6.1 Command Code

C4h

5.1.6.2 Protocol

PIO data-in

5.1.6.3 Inputs

Table 27: Read multiple command for inputs information

Register	7	6	5	4	3	2	1	0
Features	Na							
Sector Count	Sector Count							
LBA Low	LBA(7:0)							
LBA Mid	LBA(15:8)							
LBA High	LBA(23:16)							
Device	obs	Na	obs	DEV	LBA(27:24)			
Command	C4h							

Sector Count-

Number of sectors to be transferred. A value of 00h specifies that 256 sectors are to be transferred.

LBA Low-

Starting LBA bits (7:0).

LBA Mid-

Starting LBA bits (15:8)

LBA High-

Starting LBA bits (23:16)

Device –

DEV shall specify the selected device.

Bit (3:0) starting LBA bits (27:24)

5.1.6.4 Normal Output

Table 28: Read multiple command for normal output information

Register	7	6	5	4	3	2	1	0
Error	Na							
Sector Count	Na							
LBA Low	Na							
LBA Mid	Na							

LBA High	Na							
Device	obs	Na	obs	DEV	Na	Na	Na	Na
Status	BSY	DRDY	DF	Na	DRQ	Na	Na	ERR

Device register-

DEV shall specify the selected device.

Status register

BSY will be cleared to zero indicating command completion

DRDY will be set to one.

DF (Device Fault) will be cleared to zero.

DRQ will be cleared to zero

ERR will be cleared to zero.

5.1.6.5 Error Outputs

An unrecoverable error encountered during the execution of this command results in the termination of the command. The Command Block registers contain the address of the sector where the first unrecoverable error occurred. The amount of data transferred us indeterminate.

Table 29: Read multiple command for error output information

Register	7	6	5	4	3	2	1	0
Error	Na	UNC	MC	IDNF	MCR	ABRT	NM	Obs
Sector Count	Na							
LBA Low	LBA(7:0)							
LBA Mid	LBA(15:8)							
LBA High	LBA(23:16)							
Device	obs	Na	obs	DEV	LBA(27:24)			
Status	BSY	DRDY	DF	Na	DRQ	Na	Na	ERR

Error register-

UNC shall be set to one if data is uncorrectable.

IDNF shall be set to one if a user-accessible address is requested could not be found.

LBA Low, LBA Mid, and LBA High, Device

Shall be written with the address of first unrecoverable error.

Status register

BSY will be cleared to zero indicating command completion

DRDY will be set to one.

DF (Device Fault) will be cleared to zero.

DRQ will be cleared to zero

ERR will be set to one if an Error register bit is set to one.

5.1.6.6 Prerequisites

DRDY set to one.

5.1.6.7 Description

This command reads the number of sectors specified in the sector Count register.

The number of sectors per block is defined by the content of word 59 in the IDENTIFY DEVICE response.

5.1.7 Read Sector(s)

5.1.7.1 Command Code

20h

5.1.7.2 Protocol

PIO data-in

5.1.7.3 Inputs

Table 30: Read sector command for inputs information

Register	7	6	5	4	3	2	1	0
Features	Na							
Sector Count	Sector Count							
LBA Low	LBA(7:0)							
LBA Mid	LBA(15:8)							
LBA High	LBA(23:16)							
Device	obs	Na	obs	DEV	LBA(27:24)			
Command	20h							

Sector Count-

Number of sectors to be transferred. A value of 00h specifies that 256 sectors are to be transferred.

LBA Low-

Starting LBA bits (7:0).

LBA Mid-

Starting LBA bits (15:8)

LBA High-

Starting LBA bits (23:16)

Device –

DEV shall specify the selected device.

Bit (3:0) starting LBA bits (27:24)

5.1.7.4 Normal Output

Table 31: Read sector command for normal outputs information

Register	7	6	5	4	3	2	1	0
Error	Na							
Sector Count	Na							
LBA Low	Na							
LBA Mid	Na							
LBA High	Na							
Device	obs	Na	obs	DEV	Na	Na	Na	Na
Status	BSY	DRDY	DF	Na	DRQ	Na	Na	ERR

Device register-

DEV shall specify the selected device.

Status register

BSY will be cleared to zero indicating command completion

DRDY will be set to one.

DF (Device Fault) will be cleared to zero.

DRQ will be cleared to zero

ERR will be cleared to zero.

5.1.7.5 Error Outputs

An unrecoverable error encountered during the execution of this command results in the termination of the command. The Command Block registers contain the address of the sector where the first unrecoverable error occurred. The amount of data transferred is indeterminate.

Table 32: Read sector command for error outputs information

Register	7	6	5	4	3	2	1	0
Error	Na	UNC	MC	IDNF	MCR	ABRT	NM	Obs
Sector Count	Na							
LBA Low	LBA(7:0)							
LBA Mid	LBA(15:8)							
LBA High	LBA(23:16)							
Device	obs	Na	obs	DEV	LBA(27:24)			
Status	BSY	DRDY	DF	Na	DRQ	Na	Na	ERR

Error register-

UNC shall be set to one if data is uncorrectable.

IDNF shall be set to one if a user-accessible address is requested could not be found.

LBA Low, LBA Mid, and LBA High, Device

Shall be written with the address of first unrecoverable error.

Status register

BSY will be cleared to zero indicating command completion

DRDY will be set to one.

DF (Device Fault) will be cleared to zero.

DRQ will be cleared to zero

ERR will be set to one if an Error register bit is set to one.

5.1.7.6 Prerequisites

DRDY set to one.

5.1.7.7 Description

This command reads from 1 to 256 sectors as specified in the Sector Count register. A sector count of 0 requests 256 sectors. This transfer shall begin at the sector specified in the LBA Low, LBA Mid, LBA High, and Device registers.

The DRQ bit is always set to one prior to data transfer regardless of the presence or absence

of an error condition. The device shall interrupt for each DRQ block transferred.

5.1.8 Read Verify Sector

5.1.8.1 Command Code

40h

5.1.8.2 Protocol

Non-data

5.1.8.3 Inputs

Table 33: Read verify sector command for inputs information

Register	7	6	5	4	3	2	1	0
Features	Na							
Sector Count	Sector Count							
LBA Low	LBA(7:0)							
LBA Mid	LBA(15:8)							
LBA High	LBA(23:16)							
Device	obs	Na	obs	DEV	LBA(27:24)			
Command	40h							

Sector Count-

Number of sectors to be transferred. A value of 00h specifies that 256 sectors are to be transferred.

LBA Low-

Starting LBA bits (7:0).

LBA Mid-

Starting LBA bits (15:8)

LBA High-

Starting LBA bits (23:16)

Device –

The LBA bit shall be set to one to specify the address is an LBA.

DEV shall specify the selected device.

Bit (3:0) starting LBA bits (27:24)

5.1.8.4 Normal Output

Table 34: Read verify sector command for normal output information

Register	7	6	5	4	3	2	1	0
Error	Na							
Sector Count	Na							
LBA Low	Na							
LBA Mid	Na							
LBA High	Na							
Device	obs	Na	obs	DEV	Na	Na	Na	Na
Status	BSY	DRDY	DF	Na	DRQ	Na	Na	ERR

Device register-

DEV shall specify the selected device.

Status register

BSY will be cleared to zero indicating command completion

DRDY will be set to one.

DF (Device Fault) will be cleared to zero.

DRQ will be cleared to zero

ERR will be cleared to zero.

5.1.8.5 Error Outputs

An unrecoverable error encountered during the execution of this command results in the termination of the command. The Command Block registers contain the address of the sector where the first unrecoverable error occurred.

Table 35: Read verify sector command for normal output information

Register	7	6	5	4	3	2	1	0
Error	Na	UNC	MC	IDNF	MCR	ABRT	NM	Obs
Sector Count	Na							
LBA Low	LBA(7:0)							
LBA Mid	LBA(15:8)							
LBA High	LBA(23:16)							
Device	obs	Na	obs	DEV	LBA(27:24)			
Status	BSY	DRDY	DF	Na	DRQ	Na	Na	ERR

Error register-

UNC shall be set to one if data is uncorrectable.

IDNF shall be set to one if a user-accessible address could not be found.

LBA Low, LBA Mid, and LBA High, Device

Shall be written with the address of first unrecoverable error.

Status register

BSY will be cleared to zero indicating command completion

DRDY will be set to one.

DF (Device Fault) will be cleared to zero.

DRQ will be cleared to zero

ERR will be set to one if an Error register bit is set to one.

5.1.8.6 Prerequisites

DRDY set to one.

5.1.8.7 Description

This command is identical to the READ SECTOR(s) command, except that the device shall have read the data from the SSD, the DRQ bit is never set to one, and no data is transferred to the host.

5.1.9 Read DMA

5.1.9.1 Command Code

C8h

5.1.9.2 Protocol

DMA

5.1.9.3 Inputs

Table 36: Read DMA command for inputs information

Register	7	6	5	4	3	2	1	0
Features	Na							
Sector Count	Sector Count							
LBA Low	LBA(7:0)							
LBA Mid	LBA(15:8)							
LBA High	LBA(23:16)							
Device	obs	Na	obs	DEV	LBA(27:24)			
Command	C4h							

Sector Count-

Number of sectors to be transferred. A value of 00h specifies that 256 sectors are to be transferred.

LBA Low-

Starting LBA bits (7:0).

LBA Mid-

Starting LBA bits (15:8)

LBA High-

Starting LBA bits (23:16)

Device –

DEV shall specify the selected device.

Bit (3:0) starting LBA bits (27:24)

5.1.9.4 Normal Output

Table 37: Read DMA command for normal output information

Register	7	6	5	4	3	2	1	0
Error	Na							
Sector Count	Na							
LBA Low	Na							
LBA Mid	Na							
LBA High	Na							
Device	obs	Na	obs	DEV	Na	Na	Na	Na
Status	BSY	DRDY	DF	Na	DRQ	Na	Na	ERR

Device register-

DEV shall specify the selected device.

Status register

BSY will be cleared to zero indicating command completion

DRDY will be set to one.

DF (Device Fault) will be cleared to zero.

DRQ will be cleared to zero

ERR will be cleared to zero.

5.1.9.5 Error Outputs

An unrecoverable error encountered during the execution of this command results in the termination of the command. The Command Block registers contain the address of the sector where the first unrecoverable error occurred. The amount of data transferred us indeterminate.

Table 38: Read DMA command for error output information

Register	7	6	5	4	3	2	1	0
Error	ICRC	UNC	MC	IDNF	MCR	ABRT	NM	Obs
Sector Count	Na							
LBA Low	LBA(7:0)							
LBA Mid	LBA(15:8)							
LBA High	LBA(23:16)							
Device	Obs	Na	obs	DEV	LBA(27:24)			
Status	BSY	DRDY	DF	Na	DRQ	Na	Na	ERR

Error register-

ICRC shall be set to one if an interface CRC error has occurred during an Ultra DMA data transfer. The content of this bit is not applicable for Multiword DMA transfers.

UNC shall be set to one if data is uncorrectable.

IDNF shall be set to one if a user-accessible address could not be found.

LBA Low, LBA Mid, and LBA High, Device

Shall be written with the address of first unrecoverable error.

Status register

BSY will be cleared to zero indicating command completion

DRDY will be set to one.

DF (Device Fault) will be cleared to zero.

DRQ will be cleared to zero

ERR will be set to one if an Error register bit is set to one.

5.1.9.6 Prerequisites

DRDY set to one. The host shall initialize the DMA channel.

5.1.9.7 Description

The READ DMA command allows the host to read data using the DMA data transfer protocol.

5.1.10 Set Multiple Mode

5.1.10.1 Command Code

C6h

5.1.10.2 Protocol

Non-data

5.1.10.3 Inputs

If the content of the Sector Count Register is not zero, then the Sector Count register contains the number of sectors per block for the device to be used on all following READ/WRITE MULTIPLE commands. The content of the Sector Count register shall be less than or equal to the value in bits (7:0) in word 47 in the IDENTIFY DEVICE information. The host should set the content of the Sector Count register to 1.

Table 39: Set multiple mode command for inputs information

Register	7	6	5	4	3	2	1	0
Features	Na							
Sector Count	Sector per block							
LBA Low	Na							
LBA Mid	Na							
LBA High	Na							
Device	obs	Na	obs	DEV	Na			
Command	C6h							

5.1.10.4 Normal Output

Table 40: Set multiple mode command for normal output information

Register	7	6	5	4	3	2	1	0
Error	Na							
Sector Count	Na							
LBA Low	Na							
LBA Mid	Na							
LBA High	Na							
Device	obs	Na	obs	DEV	Na	Na	Na	Na
Status	BSY	DRDY	DF	Na	DRQ	Na	Na	ERR

Device register-

DEV shall specify the selected device.

Status register

BSY will be cleared to zero indicating command completion

DRDY will be set to one.

DF (Device Fault) will be cleared to zero.

DRQ will be cleared to zero

ERR will be cleared to zero.

5.1.10.5 Error Outputs

Table 41: Set multiple mode command for error outputs information

Register	7	6	5	4	3	2	1	0
Error	Na	Na	obs	Na	Na	ABRT	Na	Na
Sector Count	Na							
LBA Low	Na							
LBA Mid	Na							

LBA High	Na							
Device	Obs	Na	obs	DEV	Na			
Status	BSY	DRDY	DF	Na	DRQ	Na	Na	ERR

Status register

BSY will be cleared to zero indicating command completion

DRDY will be set to one.

DF (Device Fault) will be cleared to one if a device fault has occurred.

DRQ will be cleared to zero

ERR will be set to one if an Error register bit is set to one.

5.1.10.6 Prerequisites

DRDY set to one.

5.1.10.7 Description

This command establishes the block count for READ MULTIPLE, READ MULTI EXT, WRITE MULTIPLE.

SSD can only support 1 sector per block.

5.1.11 Set Sleep Mode

5.1.11.1 Command Code

E6h

5.1.11.2 Protocol

Non-data

5.1.11.3 Inputs

Table 42: Set sleep mode for inputs information

Register	7	6	5	4	3	2	1	0
Features	Na							
Sector Count	Na							
LBA Low	Na							
LBA Mid	Na							
LBA High	Na							
Device	obs	Na	obs	DEV	Na			
Command	E6h							

Device register–

DEV shall specify the selected device.

5.1.11.4 Normal Output

Table 43: Set sleep mode for normal output information

Register	7	6	5	4	3	2	1	0
Error	Na							
Sector Count	Na							
LBA Low	Na							
LBA Mid	Na							

LBA High	Na							
Device	obs	Na	obs	DEV	Na	Na	Na	Na
Status	BSY	DRDY	DF	Na	DRQ	Na	Na	ERR

Device register-

DEV shall specify the selected device.

Status register

BSY will be cleared to zero indicating command completion

DRDY will be set to one.

DF (Device Fault) will be cleared to zero.

DRQ will be cleared to zero

ERR will be cleared to zero.

5.1.11.5 Error Outputs

Table 44: Set sleep mode for error output information

Register	7	6	5	4	3	2	1	0
Error	Na	Na	Na	Na	Na	ABRT	Na	Na
Sector Count	Na							
LBA Low	Na							
LBA Mid	Na							
LBA High	Na							
Device	Obs	Na	obs	DEV	Na			
Status	BSY	DRDY	DF	Na	DRQ	Na	Na	ERR

Status register

BSY will be cleared to zero indicating command completion

DRDY will be set to one.

DF (Device Fault) will be set to one if a device fault has occurred.

DRQ will be cleared to zero

ERR will be set to one if an Error register bit is set to one.

5.1.11.6 Prerequisites

DRDY set to one.

5.1.11.7 Description

This command is the only way to cause the device to enter Sleep mode.

5.1.12 Flush Cache

5.1.12.1 Command Code

E7h

5.1.12.2 Protocol

Non-data

5.1.12.3 Inputs

Table 45: Flush cache command for inputs information

Register	7	6	5	4	3	2	1	0
----------	---	---	---	---	---	---	---	---

Features	Na							
Sector Count	Na							
LBA Low	Na							
LBA Mid	Na							
LBA High	Na							
Device	obs	Na	obs	DEV	Na			
Command	E7h							

Device register–

DEV shall specify the selected device.

5.1.12.4 Normal Output

Table 46: Flush cache command for normal output information

Register	7	6	5	4	3	2	1	0
Error	Na							
Sector Count	Na							
LBA Low	Na							
LBA Mid	Na							
LBA High	Na							
Device	obs	Na	obs	DEV	Na	Na	Na	Na
Status	BSY	DRDY	DF	Na	DRQ	Na	Na	ERR

Device register-

DEV shall specify the selected device.

Status register

BSY will be cleared to zero indicating command completion

DRDY will be set to one.

DF (Device Fault) will be cleared to zero.

DRQ will be cleared to zero

ERR will be cleared to zero.

5.1.12.5 Error Outputs

Table 47: Flush cache command for error output information

Register	7	6	5	4	3	2	1	0
Error	Na	Na	Na	Na	Na	ABRT	Na	Na
Sector Count	Na							
LBA Low	LBA(7:0)							
LBA Mid	LBA(15:8)							
LBA High	LBA(23:16)							
Device	Obs	Na	obs	DEV	LBA(27:24)			
Status	BSY	DRDY	DF	Na	DRQ	Na	Na	ERR

Error register-

ABRT may be set to one if the device is not able to complete the action requested by the command.

LBA Low, LBA Mid, and LBA High, Device

Shall be written with the address of first unrecoverable error.

Status register

BSY will be cleared to zero indicating command completion

DRDY will be set to one.

DF (Device Fault) will be cleared to one if a device fault has occurred.

DRQ will be cleared to zero

ERR will be set to one if an Error register bit is set to one.

5.1.12.6 Prerequisites

DRDY set to one.

5.1.12.7 Description

This command is used by the host to request the device to flush the write cache. If there is data in write cache, that data shall be written to the SSD. The BSY bit shall remain set to one until all data has been successfully written or an error occurs.

5.1.13 Standby

5.1.13.1 Command Code

E2h

5.1.13.2 Protocol

Non-data

5.1.13.3 Inputs

The value in the Sector Count register when the STANDBY command is issued shall determine the time period programmed into the Standby timer.

Table 48: Standby command for inputs information

Register	7	6	5	4	3	2	1	0
Features	Na							
Sector Count	Time period value							
LBA Low	Na							
LBA Mid	Na							
LBA High	Na							
Device	obs	Na	obs	DEV	Na			
Command	E2h							

Device register–

DEV shall specify the selected device.

5.1.13.4 Normal Output

Table 49: Standby command for normal output information

Register	7	6	5	4	3	2	1	0
Error	Na							
Sector Count	Na							
LBA Low	Na							

LBA Mid	Na							
LBA High	Na							
Device	obs	Na	obs	DEV	Na	Na	Na	Na
Status	BSY	DRDY	DF	Na	DRQ	Na	Na	ERR

Device register-

DEV shall specify the selected device.

Status register

BSY will be cleared to zero indicating command completion

DRDY will be set to one.

DF (Device Fault) will be cleared to zero.

DRQ will be cleared to zero

ERR will be cleared to zero.

5.1.13.5 Error Outputs

Table 50: Standby command for error output information

Register	7	6	5	4	3	2	1	0
Error	Na	Na	Na	Na	Na	ABRT	Na	Na
Sector Count	Na							
LBA Low	Na							
LBA Mid	Na							
LBA High	Na							
Device	Obs	Na	obs	DEV	Na			
Status	BSY	DRDY	DF	Na	DRQ	Na	Na	ERR

Error register-

ABRT may be set to one if the device is not able to complete the action requested by the command.

Status register

BSY will be cleared to zero indicating command completion

DRDY will be set to one.

DF (Device Fault) will be set to one if a device fault has occurred.

DRQ will be cleared to zero

ERR will be set to one if an Error register bit is set to one.

5.1.13.6 Prerequisites

DRDY set to one.

5.1.13.7 Description

This command causes the device to enter the Standby mode.

If the Sector Count register is non-zero then Standby timer shall be enabled. The value in the Sector Count register shall be used determine the time programmed into the Standby timer. If the Sector Count register is zero then the Standby timer is disabled.

5.1.14 Standby Immediate

5.1.14.1 Command Code

E0h

5.1.14.2 Protocol

Non-data

5.1.14.3 Inputs

Table 51: Standby immediate command for inputs information

Register	7	6	5	4	3	2	1	0
Features	Na							
Sector Count	Na							
LBA Low	Na							
LBA Mid	Na							
LBA High	Na							
Device	obs	Na	obs	DEV	Na			
Command	E0h							

Device register–

DEV shall specify the selected device.

5.1.14.4 Normal Output

Table 52: Standby immediate command for normal output information

Register	7	6	5	4	3	2	1	0
Error	Na							
Sector Count	Na							
LBA Low	Na							
LBA Mid	Na							
LBA High	Na							
Device	obs	Na	obs	DEV	Na	Na	Na	Na
Status	BSY	DRDY	DF	Na	DRQ	Na	Na	ERR

Device register-

DEV shall specify the selected device.

Status register

BSY will be cleared to zero indicating command completion

DRDY will be set to one.

DF (Device Fault) will be cleared to zero.

DRQ will be cleared to zero

ERR will be cleared to zero.

5.1.14.5 Error Outputs

Table 53: Standby immediate command for error output information

Register	7	6	5	4	3	2	1	0
Error	Na	Na	Na	Na	Na	ABRT	Na	Na
Sector Count	Na							
LBA Low	Na							

LBA Mid	Na							
LBA High	Na							
Device	Obs	Na	obs	DEV	Na			
Status	BSY	DRDY	DF	Na	DRQ	Na	Na	ERR

Error register-

ABRT may be set to one if the device is not able to complete the action requested by the command.

Status register

BSY will be cleared to zero indicating command completion

DRDY will be set to one.

DF (Device Fault) will be set to one if a device fault has occurred.

DRQ will be cleared to zero

ERR will be set to one if an Error register bit is set to one.

5.1.14.6 Prerequisites

DRDY set to one.

5.1.14.7 Description

This command causes the device to immediately enter the Standby mode.

5.1.15 Write Multiple

5.1.15.1 Command Code

C5h

5.1.15.2 Protocol

PIO data-out

5.1.15.3 Inputs

The LBA mid, LBA High, Device, and LBA Low specify the starting sector address to be written.

The Sector Count register specifies the number of sectors to be transferred.

Table 54: Write multiple command for inputs information

Register	7	6	5	4	3	2	1	0
Features	Na							
Sector Count	Sector Count							
LBA Low	LBA(7:0)							
LBA Mid	LBA(15:8)							
LBA High	LBA(23:16)							
Device	obs	Na	obs	DEV	LBA(27:24)			
Command	C5h							

Sector Count-

Number of sectors to be transferred. A value of 00h specifies that 256 sectors shall be transferred.

LBA Low-

Starting LBA bits (7:0)

LBA Mid-

Starting LBA bits (15:8)

LBA High-

Starting LBA bits (23:16)

Device –

The LBA bit shall be set to one to specify the address is an LBA.

DEV shall specify the selected device.

Bits(3:0) starting LBA bits (27:24)

5.1.15.4 Normal Output

Table 55: Write multiple command for normal output information

Register	7	6	5	4	3	2	1	0
Error	Na							
Sector Count	Na							
LBA Low	Na							
LBA Mid	Na							
LBA High	Na							
Device	obs	Na	obs	DEV	Na	Na	Na	Na
Status	BSY	DRDY	DF	Na	DRQ	Na	Na	ERR

Device register-

DEV shall specify the selected device.

Status register

BSY will be cleared to zero indicating command completion

DRDY will be set to one.

DF (Device Fault) will be cleared to zero.

DRQ will be cleared to zero

ERR will be cleared to zero.

5.1.15.5 Error Outputs

An unrecoverable error encountered during the execution of this command results in the termination of the command. The Command Block register contain the address of the sector where the first unrecoverable error occurred. The amount of data transferred is indeterminate.

Table 56: Write multiple command for normal output information

Register	7	6	5	4	3	2	1	0
Error	Na	WP	MC	IDNF	MCR	ABRT	NM	Na
Sector Count	Na							
LBA Low	LBA(7:0)							
LBA Mid	LBA(15:8)							
LBA High	LBA(23:16)							
Device	Obs	Na	obs	DEV	LBA(27:24)			
Status	BSY	DRDY	DF	Na	DRQ	Na	Na	ERR

Error register-

IDNF shall be set to one if a user-accessible address could not be found. IDNF shall be set to one if an address outside of the range user-accessible address is requested if command aborted is not returned.

ABRT shall be set to one if an error, include an ICRC error, has occurred during an Ultra DMA data transfer. ABRT shall be set to one if an address outside of the range of user-accessible address is requested if IDNF is not set to one.

LBA Low, LBA Mid, and LBA High, Device -

Shall be written with the address of first unrecoverable error.

Status register

BSY will be cleared to zero indicating command completion

DRDY will be set to one.

DF (Device Fault) will be set to one if a device fault has occurred.

DRQ will be cleared to zero

ERR will be set to one if an Error register bit is set to one.

5.1.15.6 Prerequisites

DRDY set to one. If bit 8 of IDENTIFY DEVICE word 59 is cleared to zero, a successful SET MULTIPLE MODE command shall proceed a WRITE MULTIPLE command.

5.1.15.7 Description

This command writes the number of sectors specified in the Sector Count register.

The number of sectors per block is defined by the content of word 59 of the IDENTIFY DEVICE response.

When the WRITE MULTIPLE command is issued, the SECTOR Count register contains the number of sectors (not the number of blocks) requested. The device shall interrupt for each DRQ block transferred.

IF the number of requested sectors is not evenly divisible by the block count, as many full blocks as possible are transferred, followed by a final, partial block transfer. The partial block transfer is for n sectors, where:

$N = \text{Remainder} (\text{sector count} / \text{block count})$.

If the WRITE MULTIPLE command is received when WRITE MULTIPLE commands are disabled, the Write Multiple operation shall be rejected with command aborted.

Device errors encountered during WRITE MULTIPLE commands are posted after the attempted device write of the block or partial block transferred. The command ends with the sector in error, even if the error was in the middle of a block. Subsequent blocks are not transferred in the event of an error.

The contents of the Command Block Registers following the transfer of a data block that had a sector in error are undefined. The host should retry the transfer as individual requests to obtain valid error information. Interrupt pending is set when the DRQ bit is set to one at the beginning of each block or partial block.

5.1.16 Write Sector

5.1.16.1 Command Code

30h

5.1.16.2 Protocol

PIO data-out

5.1.16.3 Inputs

The LBA mid, LBA High, Device, and LBA Low specify the starting sector address to be written.

The Sector Count register specifies the number of sectors to be transferred.

Table 57: Write sector command for inputs information

Register	7	6	5	4	3	2	1	0
Features	Na							
Sector Count	Sector Count							
LBA Low	LBA(7:0)							
LBA Mid	LBA(15:8)							
LBA High	LBA(23:16)							
Device	obs	LBA	obs	DEV	LBA(27:24)			
Command	30h							

Sector Count-

Number of sectors to be transferred. A value of 00h specifies that 256 sectors shall be transferred.

LBA Low-

Starting LBA bits (7:0)

LBA Mid-

Starting LBA bits (15:8)

LBA High-

Starting LBA bits (23:16)

Device –

The LBA bit shall be set to one to specify the address is an LBA.

DEV shall specify the selected device.

Bits(3:0) starting LBA bits (27:24)

5.1.16.4 Normal Output

Table 58: Write sector command for inputs information

Register	7	6	5	4	3	2	1	0
Error	Na							
Sector Count	Na							
LBA Low	Na							
LBA Mid	Na							
LBA High	Na							
Device	obs	Na	obs	DEV	Na	Na	Na	Na
Status	BSY	DRDY	DF	Na	DRQ	Na	Na	ERR

Device register-

DEV shall specify the selected device.

Status register

BSY will be cleared to zero indicating command completion

DRDY will be set to one.

DF (Device Fault) will be cleared to zero.

DRQ will be cleared to zero

ERR will be cleared to zero.

5.1.16.5 Error Outputs

An unrecoverable error encountered during the execution if this command results in the termination of the command. The Command Block registers contain the address of the sector where the first unrecoverable error occurred. The amount of data transferred is indeterminate.

Table 59: Write sector command for error outputs information

Register	7	6	5	4	3	2	1	0
Error	Na	WP	MC	IDNF	MCR	ABRT	NM	Na
Sector Count	Na							
LBA Low	LBA(7:0)							
LBA Mid	LBA(15:8)							
LBA High	LBA(23:16)							
Device	Obs	Na	obs	DEV	LBA(27:24)			
Status	BSY	DRDY	DF	Na	DRQ	Na	Na	ERR

Error register-

IDNF shall be set to one if a user-accessible address could not be found. IDNF shall be set to one if an address outside of the range of user-accessible addresses is requested if command aborted is not returned.

ABRT shall be set to one if an error, including an ICRC error, has occurred during an Ultra DMA data transfer. ABRT shall be set to one if the device is not able to complete the action requested by the command. ABRT shall be set to one if an address outside of the range of user-accessible addresses is requested if IDNF is not set to one.

LBA Low, LBA Mid, and LBA High, Device

Shall be written with the address of first unrecoverable error.

Status register

BSY will be cleared to zero indicating command completion

DRDY will be set to one.

DF (Device Fault) will be set to one if a device fault has occurred.

DRQ will be cleared to zero

ERR will be set to one if an Error register bit is set to one.

5.1.16.6 Prerequisites

DRDY set to one.

5.1.16.7 Description

This command writes from 1 to 256 sectors as specified in the Sector Count register. A sector count of 0 requests 256 sectors. The device shall interrupt for each DRQ block transferred.

5.1.17 Write DMA

5.1.17.1 Command Code

CAh

5.1.17.2 Protocol

DMA

5.1.17.3 Inputs

The LBA Mid, LBA High, Device, and LBA Low specify the starting sector address to be written.

The Sector Count register specifies the number of sectors to be transferred.

Table 60: Write DMA command for input information

Register	7	6	5	4	3	2	1	0
Features	Na							
Sector Count	Sector Count							
LBA Low	LBA(7:0)							
LBA Mid	LBA(15:8)							
LBA High	LBA(23:16)							
Device	obs	LBA	obs	DEV	LBA(27:24)			
Command	CAh							

Sector Count-

Number of sectors to be transferred. A value of 00h specifies that 256 sectors shall be transferred.

LBA Low-

Starting LBA bits (7:0)

LBA Mid-

Starting LBA bits (15:8)

LBA High-

Starting LBA bits (23:16)

Device –

The LBA bit shall be set to one to specify the address is an LBA.

DEV shall specify the selected device.

Bits (3:0) starting LBA bits (27:24)

Normal Output

Table 61: Write DMA command for normal output information

Register	7	6	5	4	3	2	1	0
Error	Na							
Sector Count	Na							
LBA Low	Na							
LBA Mid	Na							
LBA High	Na							

Device	obs	Na	obs	DEV	Na	Na	Na	Na
Status	BSY	DRDY	DF	Na	DRQ	Na	Na	ERR

Device register-

DEV shall specify the selected device.

Status register

BSY will be cleared to zero indicating command completion

DRDY will be set to one.

DF (Device Fault) will be cleared to zero.

DRQ will be cleared to zero

ERR will be cleared to zero.

5.1.17.4 Error Outputs

Table 62: Write DMA command for error outputs information

Register	7	6	5	4	3	2	1	0
Error	ICRC	WP	MC	IDNF	MCR	ABRT	NM	Obs
Sector Count	Na							
LBA Low	LBA(7:0)							
LBA Mid	LBA(15:8)							
LBA High	LBA(23:16)							
Device	Obs	Na	obs	DEV	LBA(27:24)			
Status	BSY	DRDY	DF	Na	DRQ	Na	Na	ERR

Error register-

ICRC shall be set to one if an interface CRC error has occurred during an Ultra DMA data transfer. The content of this bit is not applicable for Multiword DMA transfers.

IDNF shall be set to one if a user-accessible address could not be found. **IDNF** shall be set to one if an address outside of the range of user-accessible address is requested if command aborted is not returned.

ABRT shall be set to one if an error, including an **ICRC** error, has occurred during an Ultra DMA data transfer. **ABRT** shall be set to one if the device is not able to complete the action requested by the command. **ABRT** shall be set to one if an address outside of the range of user-accessible addresses is requested if **IDNF** is not set to one.

LBA Low, LBA Mid, and LBA High, Device

Shall be written with the address of first unrecoverable error.

Status register

BSY will be cleared to zero indicating command completion

DRDY will be set to one.

DF (Device Fault) will be set to one if a device fault has occurred.

DRQ will be cleared to zero

ERR will be set to one if an Error register bit is set to one.

5.1.17.5 Prerequisites

DRDY set to one. The host shall initialize the DMA channel.

5.1.17.6 Description

The Write DMA command allows the host to write data using the DMA data transfer protocol.

5.1.18 Execute Device Diagnostic

5.1.18.1 Command Code

90h

5.1.18.2 Feature Set

General feature set

5.1.18.3 Protocol

Device diagnostic

5.1.18.4 Inputs

Only the command code (90h). All other registers shall be ignored.

Table 63: Execute device diagnostic command for inputs information

Register	7	6	5	4	3	2	1	0
Features	Na							
Sector Count	Na							
LBA Low	Na							
LBA Mid	Na							
LBA High	Na							
Device	obs	Na	obs	Na	Na			
Command	90h							

Device –

DEV shall be ignored.

Normal Outputs

The diagnostic code written into the Error register is an 8-bit code.

Table 64: Execute device diagnostic command for normal outputs information

Register	7	6	5	4	3	2	1	0
Error	Diagnostic Code							
Sector Count	Signature							
LBA Low	Signature							
LBA Mid	Signature							
LBA High	Signature							
Device	Signature							
Status	BSY	DRDY	DF	Na	DRQ	Na	Na	ERR

Error register-

Diagnostic Code

Sector Count, LBA Low, LBA Mid, LBA High, Device registers

Device signature

Device register

DEV shall be cleared to zero.

Status register

TBD

Table 65: Execute device diagnostic command for status register information

Code	Description
01h	Device passed
Others	Device failed

5.1.18.5 Error Outputs

Table 10 shows the error information that is returned as a diagnostic code in the Error register.

5.1.18.6 Prerequisites

This command shall be accepted regardless of the state of DRDY.

5.1.18.7 Description

This command shall cause the devices to perform the internal diagnostic tests.

5.1.19 Security Set Password

5.1.19.1 Command Code

F1h

5.1.19.2 Feature Set

Security Mode feature set

5.1.19.3 Protocol

PIO data-out

5.1.19.4 Inputs

Table 66: Security set password command for inputs information

Register	7	6	5	4	3	2	1	0
Features	Na							
Sector Count	Na							
LBA Low	Na							
LBA Mid	Na							
LBA High	Na							
Device	obs	Na	obs	Na	Na			
Command	F1h							

Device –

DEV shall specify the selected device.

Normal Outputs

Table 67: Security set password command for normal outputs information

Register	7	6	5	4	3	2	1	0
Error	Na							
Sector Count	Na							
LBA Low	Na							
LBA Mid	Na							
LBA High	Na							

Device	obs	Na	obs	DEV	Na			
Status	BSY	DRDY	DF	Na	DRQ	Na	Na	ERR

Device register

DEV shall indicate the selected device.

Status register

BSY will be cleared to zero indicating command completion

DRDY will be set to one.

DF (Device Fault) will be set to zero.

DRQ will be cleared to zero

ERR will be set to zero.

5.1.19.5 Error Outputs

Table 68: Security set password command for error outputs information

Register	7	6	5	4	3	2	1	0
Error	Na	Na	Na	Na	Na	ABRT	Na	Na
Sector Count	Na							
LBA Low	Na							
LBA Mid	Na							
LBA High	Na							
Device	obs	Na	obs	DEV	Na			
Status	BSY	DRDY	DF	Na	DRQ	Na	Na	ERR

Error Register

ABRT may be set to one if the device is not able to complete the action requested by the command

Device register

DEV shall indicate the selected device.

Status register

BSY will be cleared to zero indicating command completion

DRDY will be set to one.

DF (Device Fault) should be set to one if a device fault has occurred.

DRQ will be cleared to zero

ERR will be set to one if an Error register bit is set to one.

5.1.19.6 Prerequisites

DRDY set to one.

5.1.19.7 Description

This command transfer 512 byte of data from the host. Table 10 defines the content of this information. The data transferred controls the function of this command. Table 11 defines the interaction of the identifier and security level bits.

The revision code field shall be returned in the IDENTIFY DEVICE word 92. The valid revision codes are 0001h through FFFEh. A value of 0000h or FFFFh indicates that the Master Password Revision Code is not supported.

Table 69: Security set password command's data content

Word	Content
0	Control Word Bit 0 Identifier 0=set User password 1=set Master password Bits (7:1) Reserved Bit(8) Security level 0=High 1=Maximum Bits(15:9) Reserved
1-16	Password(32 bytes)
17	Master Password Revision Code()
18-255	Reserved

Table 70: Security Set password command's identifier and security level bit interaction

Identifier	Level	Command result
User	High	The password supplied with the command shall be saved as the new User password. The Lock mode shall be enabled from the next power-on or hardware reset. The device shall than be unlocked by either the User password it the previously set Master password.
User	Maximum	The password supplied with the command shall be saved as the new User password. The lock mode shall be enabled from the next power-on or hardware reset. The device shall then be unlocked by only the User password. The Master password previously set is still stored in the device but shall not be unlock
Master	High or Maximum	This combination shall set a Master password but shall not enable or disable the Lock mode. The security level is not changed. Master password revision code set to the value in Master Password Revision Code field.

5.1.20 Security Unlock

5.1.20.1 Command Code

F2h

5.1.20.2 Feature Set

Security Mode feature set

5.1.20.3 Protocol

PIO data-out

5.1.20.4 Inputs

Table 71: Security unlock command for inputs information

Register	7	6	5	4	3	2	1	0
Features	Na							
Sector Count	Na							

LBA Low	Na							
LBA Mid	Na							
LBA High	Na							
Device	obs	Na	obs	Na	Na			
Command	F2h							

Device register–

DEV shall specify the selected device.

Normal Outputs

Table 72: Security unlock command for inputs information

Register	7	6	5	4	3	2	1	0
Error	Na							
Sector Count	Na							
LBA Low	Na							
LBA Mid	Na							
LBA High	Na							
Device	obs	Na	obs	DEV	Na			
Status	BSY	DRDY	DF	Na	DRQ	Na	Na	ERR

Device register

DEV shall indicate the selected device.

Status register

BSY will be cleared to zero indicating command completion

DRDY will be set to one.

DF (Device Fault) will be set to zero.

DRQ will be cleared to zero

ERR will be set to zero.

5.1.20.5 Error Outputs

The device shall return aborted if the device is in Frozen mode.

Table 73: Security unlock command for inputs information

Register	7	6	5	4	3	2	1	0
Error	Na	Na	Na	Na	Na	ABRT	Na	Na
Sector Count	Na							
LBA Low	Na							
LBA Mid	Na							
LBA High	Na							
Device	obs	Na	obs	DEV	Na			
Status	BSY	DRDY	DF	Na	DRQ	Na	Na	ERR

Error Register

ABRT may be set to one if the device is not able to complete the action requested by the command

Device register

DEV shall indicate the selected device.

Status register

BSY will be cleared to zero indicating command completion

DRDY will be set to one.

DF (Device Fault) should be set to one if a device fault has occurred.

DRQ will be cleared to zero

ERR will be set to one if an Error register bit is set to one.

5.1.20.6 Prerequisites

DRDY set to one.

5.1.20.7 Description

This command transfers 512 bytes of data from the host. Table13 defines the content of this information. If the Identifier bit is set to Master and the device is in high security level, then the password supplied shall be compared with the stored Master password. If the device is in maximum security level then the unlock shall be rejected.

If the Identifier bit is set to user then the device shall compare the supplied password with the stored User password. If the password compare fails then the device shall return command aborted to the host and decrements the unlock counter. This counter shall be initially set to five and shall decremented for each password mismatch when SECURITY UNLOCK and SECURITY ERASE UNIT commands shall be command aborted until a power-on reset or a hardware reset. SECURITY UNLOCK commands issued when the device is unlocked have no effect on the unlock counter.

5.1.21 Security Erase Prepare

5.1.21.1 Command Code

F3h

5.1.21.2 Feature Set

Security Mode feature set

5.1.21.3 Protocol

Non-data

5.1.21.4 Inputs

Table 74: Security erase prepare command for inputs information

Register	7	6	5	4	3	2	1	0
Features	Na							
Sector Count	Na							
LBA Low	Na							
LBA Mid	Na							
LBA High	Na							
Device	obs	Na	obs	Na	Na			
Command	F3h							

Device register–

DEV shall specify the selected device.

Normal Outputs

Table 75: Security erase prepare command for normal outputs information

Register	7	6	5	4	3	2	1	0
Error	Na							
Sector Count	Na							
LBA Low	Na							
LBA Mid	Na							
LBA High	Na							
Device	obs	Na	obs	DEV	Na	Na	Na	Na
Status	BSY	DRDY	DF	Na	DRQ	Na	Na	ERR

Device register

DEV shall indicate the selected device.

Status register

BSY will be cleared to zero indicating command completion

DRDY will be set to one.

DF (Device Fault) will be set to zero.

DRQ will be cleared to zero

ERR will be set to zero.

5.1.21.5 Error Outputs

The device shall return aborted if the device is in Frozen mode.

Table 76: Security erase prepare command for error outputs information

Register	7	6	5	4	3	2	1	0
Error	Na	Na	Na	Na	Na	ABRT	Na	Na
Sector Count	Na							
LBA Low	Na							
LBA Mid	Na							
LBA High	Na							
Device	obs	Na	obs	DEV	Na			
Status	BSY	DRDY	DF	Na	DRQ	Na	Na	ERR

Error Register

ABRT shall be set to one if the device is in Frozen mode. ABRT may be set to one if the device is not able to complete the action requested by the command

Device register

DEV shall indicate the selected device.

Status register

BSY will be cleared to zero indicating command completion

DRDY will be set to one.

DF (Device Fault) should be set to one if a device fault has occurred.

DRQ will be cleared to zero

ERR will be set to one if an Error register bit is set to one.

5.1.21.6 Prerequisites

DRDY set to one.

5.1.21.7 Description

The SECURITY ERASE PREPARE command shall be issued immediately before the SECURITY ERASE UNIT command to enable device erasing and unlocking. This command prevents accidental loss of data on the device.

5.1.22 Security Erase Unit

5.1.22.1 Command Code

F4h

5.1.22.2 Feature Set

Security Mode feature set

5.1.22.3 Protocol

PIO data-out.

5.1.22.4 Inputs

Table 77: Security erase unit command for inputs information

Register	7	6	5	4	3	2	1	0
Features	Na							
Sector Count	Na							
LBA Low	Na							
LBA Mid	Na							
LBA High	Na							
Device	obs	Na	obs	Na	Na	Na	Na	Na
Command	F4h							

Device register–

DEV shall specify the selected device.

Normal Outputs

Table 78: Security erase unit command for normal outputs information

Register	7	6	5	4	3	2	1	0
Error	Na							
Sector Count	Na							
LBA Low	Na							
LBA Mid	Na							
LBA High	Na							
Device	obs	Na	obs	DEV	Na	Na	Na	Na
Status	BSY	DRDY	DF	Na	DRQ	Na	Na	ERR

Device register

DEV shall indicate the selected device.

Status register

BSY shall be cleared to zero indicating command completion

DRDY shall be set to one.

DF (Device Fault) will be set to zero.

DRQ shall be cleared to zero

ERR shall be cleared to zero.

5.1.22.5 Error Outputs

The device shall return aborted if the device is in Frozen mode, not preceded by a SECURITY ERASE PREPARE command, if Enhance Erase is specified but not supported, or if the data area is not successfully overwritten.

Table 79: Security erase unit command for error outputs information

Register	7	6	5	4	3	2	1	0
Error	Na	Na	Na	Na	Na	ABRT	Na	Na
Sector Count	Na							
LBA Low	Na							
LBA Mid	Na							
LBA High	Na							
Device	obs	Na	obs	DEV	Na			
Status	BSY	DRDY	DF	Na	DRQ	Na	Na	ERR

Error Register

ABRT shall be set to one if the device is in Frozen mode, not preceded by a SECURITY ERASE PREPARE command, or if the data area is not successfully overwritten. ABRT may be set to one if the device is not able to complete the action requested by the command.

Device register

DEV shall indicate the selected device.

Status register

BSY will be cleared to zero indicating command completion

DRDY will be set to one.

DF (Device Fault) should be set to one if a device fault has occurred.

DRQ will be cleared to zero

ERR will be set to one if an Error register bit is set to one.

5.1.22.6 Prerequisites

DRDY set to one. This command shall be immediately preceded by a SECURITY ERASE PREPARE command.

5.1.22.7 Description

This command transfer 512 bytes of data from the host. Table12 defines the content of this information. If the password does not match the password previously saved by the device, the device shall reject the command with command aborted.

The SECURITY ERASE PREPARE command shall be completed immediately prior to the SECURITY ERASE UNIT command. If the device receives a SECURITY ERASE UNIT command without an immediately prior SECURITY ERASE PREPARE command, the device shall command abort the SECURITY ERASE UNIT command.

When Normal Erase mode is specified, the SECURITY ERASE UNIT command shall write binary zeroes to all user data areas. The Enhanced Erase mode is optional. When Enhanced Erase Mode is specified, the device shall write predetermined data patterns to all user areas. In Enhanced Erase mode, all previously written user data shall be overwritten, including sectors that are no longer in use due to reallocation.

This command shall disable the device Lock mode, however, the Master password shall still be stored internally within the device and may be reactivated later a new User password is set.

Table 80: Security erase unit password information

Word	Content
0	Control Word Bit 0 Identifier 0=Compare User password 1= Compare Master password Bit 1 Erase mode 0=Normal Erase 1=Enhanced Erase Bit(15:2) Reserved
1-16	Password (32 Bytes)
17-255	Reserved

5.1.23 Security Freeze Lock

5.1.23.1 Command Code

F5h

5.1.23.2 Feature Set

Security Mode feature set

5.1.23.3 Protocol

Non-data.

5.1.23.4 Inputs

Table 81: Security freeze lock for inputs information

Register	7	6	5	4	3	2	1	0
Features	Na							
Sector Count	Na							
LBA Low	Na							
LBA Mid	Na							
LBA High	Na							
Device	Obs	Na	obs	Na	Na	Na	Na	Na
Command	F5h							

Device register–

DEV shall specify the selected device.

Normal Outputs

Table 82: Security freeze lock for normal outputs information

Register	7	6	5	4	3	2	1	0
----------	---	---	---	---	---	---	---	---

Error	Na							
Sector Count	Na							
LBA Low	Na							
LBA Mid	Na							
LBA High	Na							
Device	Obs	Na	obs	DEV	Na	Na	Na	Na
Status	BSY	DRDY	DF	Na	DRQ	Na	Na	ERR

Device register

DEV shall indicate the selected device.

Status register

BSY shall be cleared to zero indicating command completion

DRDY shall be set to one.

DF (Device Fault) will be set to zero.

DRQ shall be cleared to zero

ERR shall be cleared to zero.

5.1.23.5 Error Outputs

The device shall return aborted if the device is in Frozen mode, not preceded by a SECURITY ERASE PREPARE command, if Enhance Erase is specified but not supported, or if the data area is not successfully overwritten.

Table 83: Security freeze lock for error outputs information

Register	7	6	5	4	3	2	1	0
Error	Na	Na	Na	Na	Na	ABRT	Na	Na
Sector Count	Na							
LBA Low	Na							
LBA Mid	Na							
LBA High	Na							
Device	Obs	Na	obs	DEV	Na			
Status	BSY	DRDY	DF	Na	DRQ	Na	Na	ERR

Error Register

ABRT shall be set to one if the device is in locked mode. ABRT may be set to one if the device is not able to complete the action requested by the command.

Device register

DEV shall indicate the selected device.

Status register

BSY will be cleared to zero indicating command completion

DRDY will be set to one.

DF (Device Fault) should be set to one if a device fault has occurred.

DRQ will be cleared to zero

ERR will be set to one if an Error register bit is set to one.

5.1.23.6 Prerequisites

DRDY set to one.

5.1.23.7 Description

The SECURITY FREEZE LOCK command shall set the device to Frozen mode. After command completion any other commands that update the device Lock mode shall be command aborted. Frozen mode shall be disabled by power-off or hardware reset. If SECURITY FREEZE LOCK shall be issued when the device in Frozen mode, the command executes and the device shall remain in Frozen mode.

Command disabled by SECURITY FREEZE LOCK are:

- SECURITY SET PASSWORD
- SECURITY UNLOCK
- SECURITY DISABLE PASSWORD
- SECURITY ERASE PREPARE
- SECURITY ERASE UNIT

5.1.24 Security Disable Password

5.1.24.1 Command Code

F6h

5.1.24.2 Feature Set

Security Mode feature set

5.1.24.3 Protocol

PIO data-out.

5.1.24.4 Inputs

Table 84: Security disable password command for inputs information

Register	7	6	5	4	3	2	1	0
Features	Na							
Sector Count	Na							
LBA Low	Na							
LBA Mid	Na							
LBA High	Na							
Device	obs	Na	obs	Na	Na	Na	Na	Na
Command	F6h							

Device register–

DEV shall specify the selected device.

Normal Outputs

Table 85: Security disable password command for normal outputs information

Register	7	6	5	4	3	2	1	0
Error	Na							
Sector Count	Na							
LBA Low	Na							
LBA Mid	Na							

LBA High	Na							
Device	obs	Na	obs	DEV	Na	Na	Na	Na
Status	BSY	DRDY	DF	Na	DRQ	Na	Na	ERR

Device register

DEV shall indicate the selected device.

Status register

BSY shall be cleared to zero indicating command completion

DRDY shall be set to one.

DF (Device Fault) will be set to zero.

DRQ shall be cleared to zero

ERR shall be cleared to zero.

5.1.24.5 Error Outputs

The device shall return aborted if the device is in Locked mode, or device is in Frozen mode.

Table 86: Security disable password command for error outputs information

Register	7	6	5	4	3	2	1	0
Error	Na	Na	Na	Na	Na	ABRT	Na	Na
Sector Count	Na							
LBA Low	Na							
LBA Mid	Na							
LBA High	Na							
Device	obs	Na	obs	DEV	Na			
Status	BSY	DRDY	DF	Na	DRQ	Na	Na	ERR

Error Register

ABRT may be set to one if the device is not able to complete the action requested by the command.

Device register

DEV shall indicate the selected device.

Status register

BSY will be cleared to zero indicating command completion

DRDY will be set to one.

DF (Device Fault) should be set to one if a device fault has occurred.

DRQ will be cleared to zero

ERR will be set to one if an Error register bit is set to one.

5.1.24.6 Prerequisites

DRDY set to one. Device shall be in Unlocked mode.

5.1.24.7 Description

The SECURITY DISABLE PASSWORD command transfer 512 bytes of data from the host. Table 13 defines the content of this information. If the password selected by word 0 matches the password previously saved by the device, the device shall disable the Lock mode. This command shall not change the Master password. The Master password shall be reactivated

when a User password is set.

Table 87: Security disable password command content

Word	Content
0	Control Word Bit 0 Identifier 0=Compare User password 1= Compare Master password Bit(15:1) Reserved
1-16	Password (32 Bytes)
17-255	Reserved

6. Part Number Rule

CODE	1	2	3	4	5	6	7	8	9	10	11	12	13	14	15	16	17	18	19	20
	D	R	P	P	-	1	6	G	J	3	0	A	C	1	Q	S				
Description	Disk	Mini PCIeDOM			-	Capacity			Category			FW	Operation Temp.	Internal Control	CH.	Flash	-	Customized Code		
Definition																				
Code 1st (Disk)												Code 13th (Operation Temperature)								
D : Disk												C: Standard Grade (0°C ~ +70°C)								
Code 2nd ~ 4th (Form Factor)												Code 14th (Internal control)								
RPP: Mini PCIeDOM												K: Standard Grade with coating								
Code 6th ~8th (Capacity)												Code 15th (Channel of data transfer)								
02G: 2GB												S: Single Channel								
04G: 4GB												D: Dual Channels								
08G:8GB												Q: Four Channels								
16G: 16GB																				
32G: 32GB																				
Code 9th ~11th (Series)												Code 16th (Flash Type)								
J30: InnoDisk Mini PCIeDOM D150, InnoDisk D150 series																				
Code 12th (Firmware version)																				
A: Standard F/W version																				