

DATA IMAGE CORPORATION

LCD Module Specification

ITEM NO.: GM322405GNCWAGT1

Table of Contents

1. COVER & CONTENTS	1
2. RECORD OF REVISION	2
3. GENERAL SPECIFICATIONS	3
4. ABSOLUTE MAXIMUM RATINGS	4
5. ELECTRICAL CHARACTERISTICS	6
6. ELECTRO-OPTICAL CHARACTERISTIC	6
7. PIN CONNECTIONS.....	9
8. POWER SUPPLY	9
9. BLOCK DIAGRAM	10
10. TOUCH PANEL CHARACTERISTICS	11
11. QUALITY ASSURANCE	13
12. LOT NUMBERING SYSTEM	17
13. LCM NUMBERING SYSTEM	17
14. PRECAUTIONS IN USE LCM	18
15. OUTLINE DRAWING	19
16. PACKAGE INFORMATION	20

Customer Companies	R&D Dept.	Q.C. Dept.	Eng. Dept.	Prod. Dept.
	JACK	ERIC	KEN	HELEN
Approved by	Version:	Issued Date:	Sheet Code:	Total Pages:
	A	2006/1/23		20

3. GENERAL SPECIFICATION

Display Format : 320 (W) × 240 (H) dots
Dot Size : 0.33 (W) × 0.33 (H) mm
View Area : 122 (W) × 92 (H) mm
Outline Dimensions : 167.1 (W) × 109.0 (H) × 12 (T) mm Max.
Weight : 210g max.

LCD Type : STN Blue STN Yellow FSTN TN

Polarizer mode : Reflective Transflective

Transmissive Negative

View Angle : 6 O'clock 12 O'clock Others _____

Backlight : LED EL CCFL

Backlight Color : Yellow green Amber Blue Green

White Others

Controller / Driver : RA8835,NT7086

Temperature Range : Normal Wide Temperature
Operating 0 to 50°C Operating -20 to 70°C
Storage -20 to 70°C Storage -30 to 80°C

REMARK:

Our components and processes are compliant to RoHS standard

4. ABSOLUTE MAXIMUM RATINGS

4.1 ELECTRICAL ABSOLUTE MAXIMUM RATINGS

GND= 0V, Ta = 25°C

Item	Symbol	Min.	Max.	Unit
Supply Voltage (Logic)	V _{DD} -GND	0	6.5	V
Supply Voltage (LCD Driver)	V _{DD} -V _{EE}	0	27.5	V
Input Voltage	V _I	GND	V _{DD}	V
Operating Temperature	T _{OP}	0	50	°C
Storage Temperature	T _{STG}	-20	70	°C

4.2 ENVIRONMENTAL ABSOLUTE MAXIMUM RATINGS

Item	Operating		Storage		Comment
	(Min.)	Max.)	(Min.)	(Max.)	
Ambient Temp	0	50	-20	70	Note (1)
Humidity	Note (2)		Note(2)		Without Condensation
Vibration	--	4.9M/S ²	--	19.6M/S ²	XYZ Direction
Shock	--	29.4M/S ²	--	490M/S ²	XYZ Direction

Note(1) Ta = 0°C : 50Hr Max.

Note(2) Ta ≤ 40°C : 90% RH Max.

Ta ≥ 40°C : Absolute humidity must be lower than the humidity of 90% RH at 40°C.

4.3 Electronic Static Discharge maximum rating

ESD test method : IEC1000-4-2

Item	Description	
Testing environment	Ambient temperature :15°C to 35 °C Humidity: 30% to 60 % LCM (E.U.T) : Power up	
Testing equipment	Manufacture: Noise Ken, Model No. ESD-100L	
Testing condition	See drawing 1	
Direct discharge	0 to ± 6 KV	Discharge point, see drawing 2
Indirect discharge	0 to ± 12KV	Discharge point, see drawing 1
Pass condition	No malfunction of unit. Temporary malfunction of unit which can be recovered by system reset	
Fail condition	Non. Recoverable malfunction of LCM or system	

FIG 1 ESD TESTING EQUIPMENT

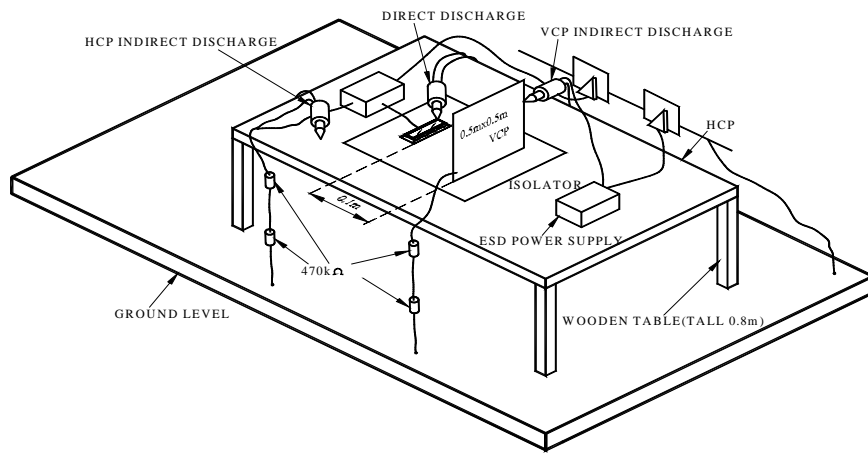

(1)

DIRECT CONTACT DISCHARGE CONTACT POINT : A.B.C.D

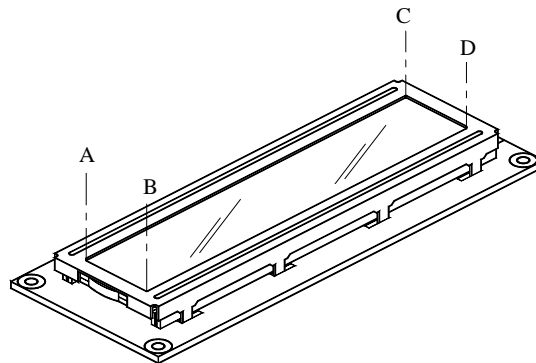

(2)

5. ELECTRICAL CHARACTERISTICS

Item	Symbol	Condition	Min.	Typ.	Max.	Unit
Supply Voltage (Logic)	V _{DD-GND}		2.7	5.0	5.5	V
Supply Voltage (LCD)	V _{DD-V_O}	0°C	--	--	--	V
		25°C	23.3	23.9	24.5	
		50°C	--	--	--	
Input Voltage	V _{IH}	V _{DD-GND} = 2.7~5.5V	0.8*V _{DD}	--	V _{DD}	V
	V _{IL}		GND	--	0.2*V _{DD}	
Logic Supply Current	I _{DD}	V _{DD-GND} = 5V	--	50	--	mA

6. ELECTRO-OPTICAL CHARACTERISTICS

ITEM	Symbol	Condition	Min.	Typ.	Max.	Unit	Ref.
Rise Time	Tr	0°C	--	--	--	ms	Note (1)
		25°C		--	350		
Fall Time	Tf	0°C	--	--	--	ms	
		25°C		--	350		
Contrast	CR	25°C	3	--	--		Note (3)
View Angle	θ ₁ ~θ ₂ ∅ ₁ , ∅ ₂	25°C & CR≥2	-20~30				Note (2)
			-30~30				
Frame Frequency	Ff	25°C	32	64	200	Hz	

Note (1) & (2) : See next page

Note (3) : Contrast ratio is defined under the following condition:

$$CR = \frac{\text{Brightness of non-selected condition}}{\text{Brightness of selected condition}}$$

- (a). Temperature ----- 25°C
- (b). Frame frequency ---- 64Hz
- (c). Viewing angle ----- θ= 0°, ∅ = 0°
- (d). Operating voltage --- 23.9V

Note (1) Response time is measured as the shortest period of time possible between the change in state of an LCD segment as demonstrated below:

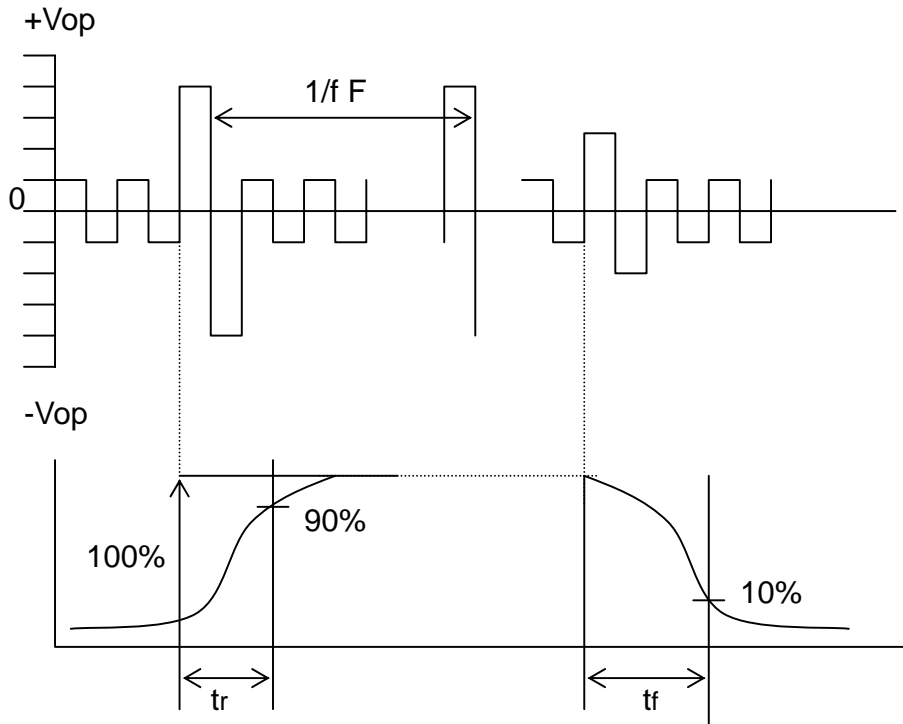

Condition:

- (a) . Temperature ----- $25^{\circ}C$
- (b) . Frame frequency ----- 64Hz
- (c) . View Angle ----- $\theta = 0^{\circ}$, $\phi = 0^{\circ}$
- (d) . Operating voltage ----- 23.9V

Note (2) Definition of View Angle

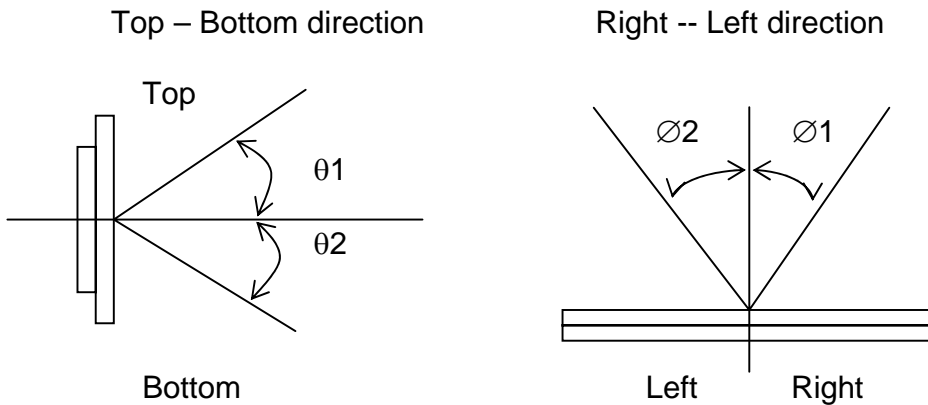

6.1 CCFL ELECTRICAL CHARACTERISTICS

Item	Condition
Start Voltage	600 Vrms typ,at Ta=25°C
Tube Voltage	300Vrms typ,at Ta=25°C
Tube Current	5m Arms typ ,at Ta=25°C
Drive Frequency	45 KHz , typ at Ta=25°C

6.1.2 Initial Optical Characteristics

Item	Condition	
Brightness Uniformity	65% min.	
Average Brightness	550 cd/m ² mean	
Chromaticity	X	0.34±0.02
	Y	0.37±0.02

6.1.3 Environmental Conditions

Item	Temperature	Humidity	Unit
Operating	0 to 50°C	20 to 90%	RH
Storage	-20 to 70°C	5 to 90%	RH

Recommend CCFL inverter:

TDK L10L operation voltage +12V , 300mA

TDK L10A operation voltage +5V , 600mA

7. PIN CONNECTIONS

No.	Symbol	Function
1	/RES	LCD Controller Function reset
2	/RD	Data read
3	/WR	Data write
4	/CS	LCD IC Chip Select
5	A0	Command / Data Select
6	D0	Data bus line 0
7	D1	Data bus line 1
8	D2	Data bus line 2
9	D3	Data bus line 3
10	D4	Data bus line 4
11	D5	Data bus line 5
12	D6	Data bus line 6
13	D7	Data bus line 7
14	VDD	Logic Power input
15	GND	Ground(0V)
16	VEE	Negative voltage output
17	VO	LCD contrast control
18	/DISPOFF	Display on/off control, High= ON Low= OFF

8. POWER SUPPLY

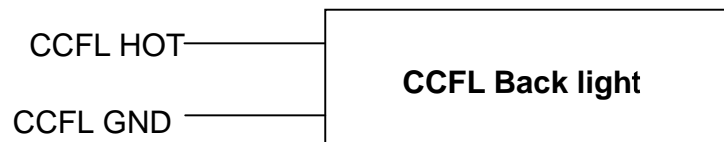
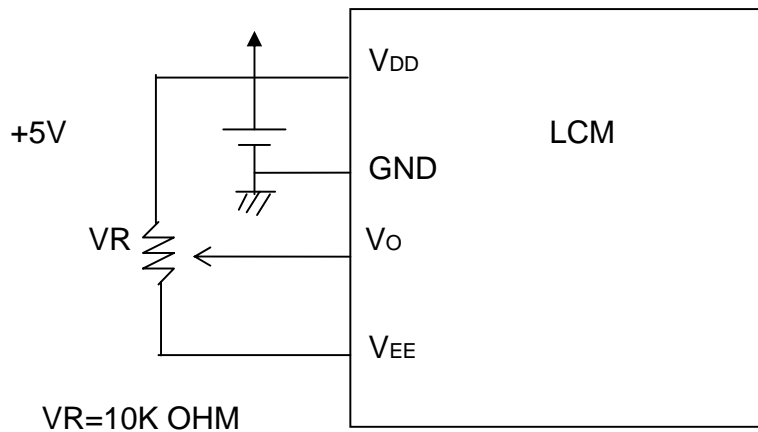

9. BLOCK DIAGRAM

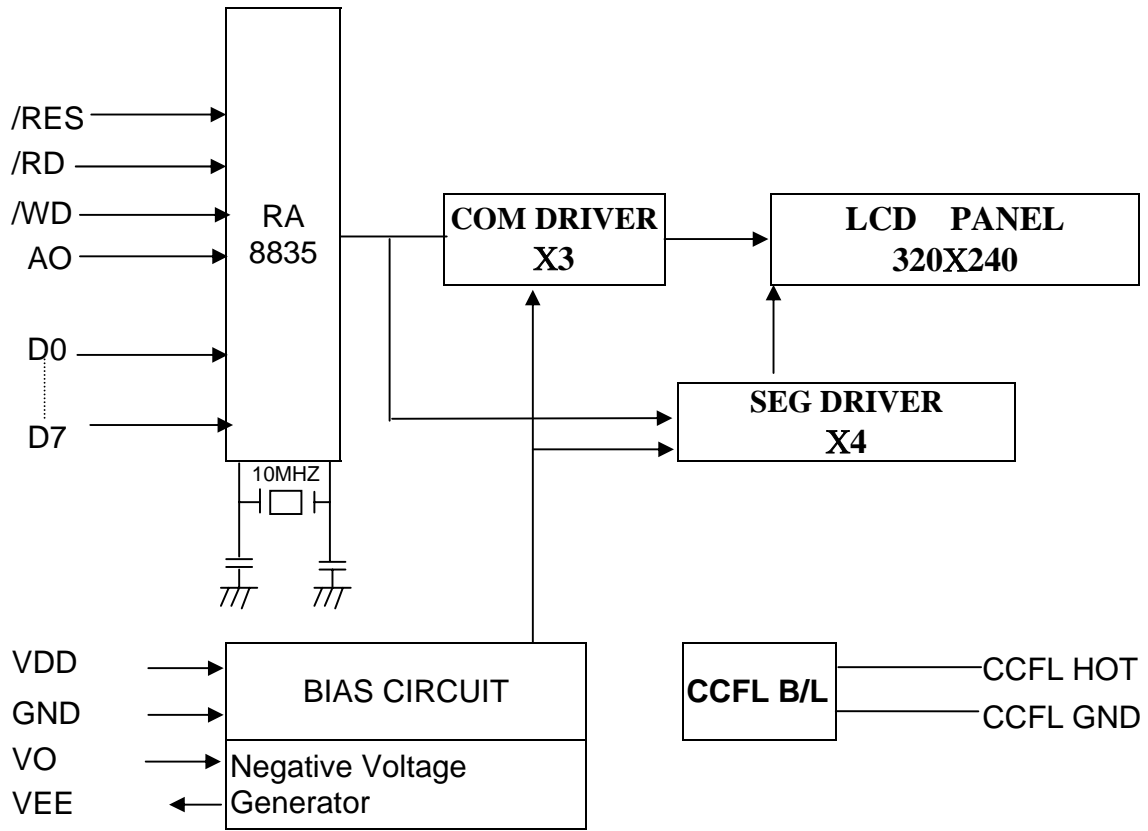

*LCD Controller's Timing and Function .Please Refer to the RA8835.PDF SPEC.

10. TOUCH PANEL CHARACTERISTICS

1. Mechanical Dimensions and Construction

1.1 General: Pen Mount Analog touch screen is laminated by ITO PET to ITO glass.

1.2 Construction:

Item	Description	Material	Remarks
1	ITO PET TOP layer	ITO PET Film	Antiglare coating Surface hardness:3H Resistance:300~600Ω
2	ITO Patterned Glass Bottom layer	1.1mm ITO Glass	Resistance: 300~600Ω
3	Tail	PET Film	Integral to Top layer circuit
4	Tail insulation	PET Film	
5	Connector	Amp compatible	Pitch:2.54mm
6	Top layer silver bus	Silver ink	
7	Bottom Layer silver bus	Silver ink	
8	Silver bus contact layer	Silver ink	
9	Dot spacer	UV Cure ink	
10	Isolation layer	Isolation Adhesive	

Remark : This model is with ANR design.

1.3 Input Method Activation Force

Input Method	Average Activation Force
1.6mm dia. Delrin stylus	0.10~0.70N
16mm dia. Silicon "finger"	0.10~0.80N

2. Typical Optical Characteristics

2.1 Visible Light Transmission:>80%

2.2 Haze:<13

3. Electrical Specification

3.1 Operating Voltage 5.5V or less

3.2 Contact current 20mA(maximum)

3.3 Circuit close resistance X:350~1000Ω
Y:200~650Ω

3.4 Circuit open resistance:>10MΩ at 25VDC

3.5 Contact bounce:<10ms

3.6 Linear Test: <1.5%

3.7 Capacitance:100nF(maximum)

4. Linearity

4.1 Linear Test Specification

Direction X: <1.5 %

Direction Y: <1.5 %

4.2 Linearity Test

Apply voltage (DC5V) to upper (or lower) electrodes,
output voltage V_x or V_y on the other electrodes is measured
at every regular intervals.

5.Environment Specification

- 5.1 Operating Temperature** $-10^{\circ}\text{C} \sim + 60^{\circ}\text{C}$
Humidity less than 80 %RH
No dew condensation
- 5.2 Storage Temperature** $-40^{\circ}\text{C} \sim + 80^{\circ}\text{C}$
at Ambient Humidity

6. Optical Performance

- 6.1 Optical inspection method and optical defect standards refer to AMT document. A001updated version ; "Touch Screen Optical Quality Standard."**
- 6.2 Outside to Viewing Area : any optical defected in this area need to be ignored if no effected to touch screen function.**
- 6.3 Others**
 - 6.3.1 Always store the touch screen in its original shipping container under normal conditions(20~25 65%RH)**

11. QUALITY ASSURANCE

11.1 Test Condition

11.1.1 Temperature and Humidity(Ambient Temperature)

11.1.2 Temperature : $20 \pm 5^{\circ}\text{C}$

Humidity : $65 \pm 5\%$

11.1.3 Operation

Unless specified otherwise, test will be conducted under function state.

11.1.4 Container

Unless specified otherwise, vibration test will be conducted to the product itself without putting it in a container.

11.1.5 Test Frequency

In case of related to deterioration such as shock test. It will be conducted only once.

11.1.6 Test Method

No.	Parameter	Conditions	Regulations
1	High Temperature Operating	$50 \pm 2^{\circ}\text{C}$	Note 3
2	Low Temperature Operating	$0 \pm 2^{\circ}\text{C}$	Note 3
3	High Temperature Storage	$70 \pm 2^{\circ}\text{C}$	Note 3
4	Low Temperature Storage	$-20 \pm 2^{\circ}\text{C}$	Note 3
5	Vibration Test (Non-operation state)	Total fixed amplitude : 1.5mm Vibration Frequency : 10 ~ 55Hz One cycle 60 seconds to 3 directions of X.Y.Z. for each 15 minutes	Note 3
6	Damp Proof Test (Non-operation state)	$40^{\circ}\text{C} \pm 2^{\circ}\text{C}$, 90~95%RH, 96h	Note 1,2
7	Shock Test (Non-operation state)	To be measured after dropping from 60cm high once concrete surface in packing state	Note 3

Note 1: Returned under normal temperature and humidity for 4 hrs.

Note 2: No dew condensation to be observed.

Note 3: No change on display and in operation under the test condition

11.2 Inspection condition

11.2.1 Inspection conditions

The LCD shall be inspected under 40W white fluorescent light.

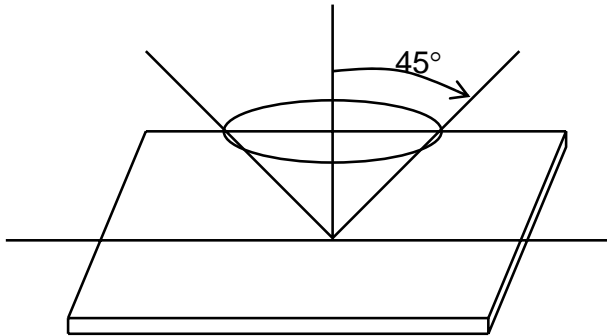

11.2.2 Definition of applicable Zones

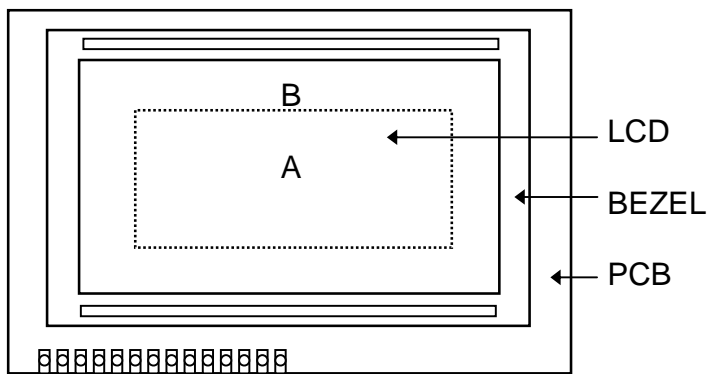

A : Display Area
B : Non-Display Area

11.2.3 Inspection Parameters

No.	Parameter	Criteria																												
1	Black or White spots	<table border="1"> <thead> <tr> <th rowspan="2">Zone Dimension</th> <th colspan="2">Acceptable number</th> <th rowspan="2">Class Of Defects</th> <th rowspan="2">AQL Level</th> </tr> <tr> <th>A</th> <th>B</th> </tr> </thead> <tbody> <tr> <td>D < 0.15</td> <td>*</td> <td>*</td> <td rowspan="4">Minor</td> <td rowspan="4">2.5</td> </tr> <tr> <td>0.15 ≤ D < 0.2</td> <td>4</td> <td>4</td> </tr> <tr> <td>0.2 ≤ D ≤ 0.25</td> <td>2</td> <td>2</td> </tr> <tr> <td>D ≤ 0.3</td> <td>0</td> <td>1</td> </tr> </tbody> </table> <p style="text-align: center;">D = (Long + Short) / 2 * : Disregard</p>	Zone Dimension	Acceptable number		Class Of Defects	AQL Level	A	B	D < 0.15	*	*	Minor	2.5	0.15 ≤ D < 0.2	4	4	0.2 ≤ D ≤ 0.25	2	2	D ≤ 0.3	0	1							
Zone Dimension	Acceptable number			Class Of Defects	AQL Level																									
	A	B																												
D < 0.15	*	*	Minor	2.5																										
0.15 ≤ D < 0.2	4	4																												
0.2 ≤ D ≤ 0.25	2	2																												
D ≤ 0.3	0	1																												
2	Scratch, Substances	<table border="1"> <thead> <tr> <th colspan="2">Zone</th> <th colspan="2">Acceptable number</th> <th rowspan="2">Class Of Defects</th> <th rowspan="2">AQL Level</th> </tr> <tr> <th>X (mm)</th> <th>Y(mm)</th> <th>A</th> <th>B</th> </tr> </thead> <tbody> <tr> <td>*</td> <td>0.04 ≥ W</td> <td>*</td> <td>*</td> <td rowspan="4">Minor</td> <td rowspan="4">2.5</td> </tr> <tr> <td>3.0 ≥ L</td> <td>0.06 ≥ W</td> <td>4</td> <td>4</td> </tr> <tr> <td>2.0 ≥ L</td> <td>0.08 ≥ W</td> <td>2</td> <td>3</td> </tr> <tr> <td>—</td> <td>0.1 < W</td> <td>0</td> <td>1</td> </tr> </tbody> </table> <p style="text-align: center;">X : Length Y : Width * : Disregard Total defects should not exceed 4/module</p>	Zone		Acceptable number		Class Of Defects	AQL Level	X (mm)	Y(mm)	A	B	*	0.04 ≥ W	*	*	Minor	2.5	3.0 ≥ L	0.06 ≥ W	4	4	2.0 ≥ L	0.08 ≥ W	2	3	—	0.1 < W	0	1
Zone		Acceptable number		Class Of Defects	AQL Level																									
X (mm)	Y(mm)	A	B																											
*	0.04 ≥ W	*	*	Minor	2.5																									
3.0 ≥ L	0.06 ≥ W	4	4																											
2.0 ≥ L	0.08 ≥ W	2	3																											
—	0.1 < W	0	1																											
3	Air Bubbles (between glass & polarizer)	<table border="1"> <thead> <tr> <th rowspan="2">Zone Dimension</th> <th colspan="2">Acceptable number</th> <th rowspan="2">Class of Defects</th> <th rowspan="2">AQL Level</th> </tr> <tr> <th>A</th> <th>B</th> </tr> </thead> <tbody> <tr> <td>D ≤ 0.15</td> <td>*</td> <td>*</td> <td rowspan="3">Minor</td> <td rowspan="3">2.5</td> </tr> <tr> <td>0.15 < D ≤ 0.25</td> <td>2</td> <td>*</td> </tr> <tr> <td>0.25 < D</td> <td>0</td> <td>1</td> </tr> </tbody> </table> <p style="text-align: center;">* : Disregard Total defects shall not excess 3/module.</p>	Zone Dimension	Acceptable number		Class of Defects	AQL Level	A	B	D ≤ 0.15	*	*	Minor	2.5	0.15 < D ≤ 0.25	2	*	0.25 < D	0	1										
Zone Dimension	Acceptable number			Class of Defects	AQL Level																									
	A	B																												
D ≤ 0.15	*	*	Minor	2.5																										
0.15 < D ≤ 0.25	2	*																												
0.25 < D	0	1																												
4	Uniformity of Pixel	<p>(1) Pixel shape (with Dent)</p>																												

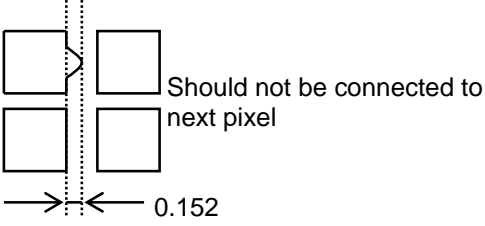
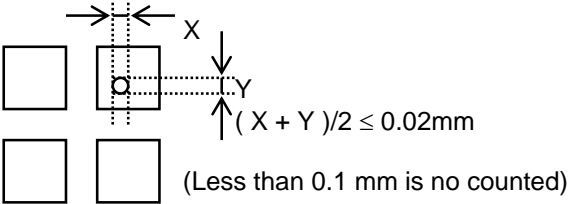
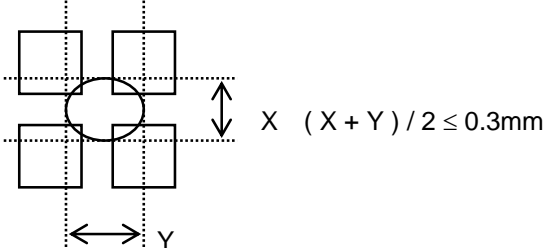
4	Uniformity of Pixel		<p>(2) Pixel shape (with Projection)</p>  <p>(3) Pin hole</p>  <p>(4) Deformation</p>  <p>Total acceptable number : 1/pixel, 5/cell</p>
	Class of defects	Major	<p>Definition</p> <p>AQL 0.65% It is a defect that is likely to result in failure or to reduce materially the usability of the product for the intended function.</p> <p>AQL 1.00% It is a defect that is likely to assembly size and not result in functioning problem.</p>
	Minor	<p>AQL 2.5% It is a defect that will not result in functioning problem with deviation classified.</p>	

11.3 Sampling Condition

Unless otherwise agree in written, the sampling inspection shall be applied to the incoming inspection of customer.

Lot size: Quantity of shipment lot per model.

Sampling type: normal inspection, single sampling

Sampling table: MIL-STD-105E

Inspection level: Level II

12. LOT NUMBERING SYSTEM

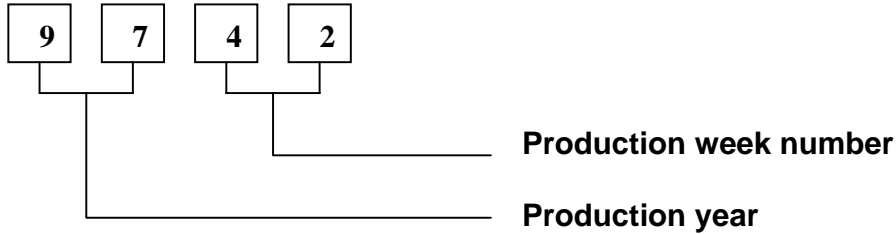

13. LCM NUMBERING SYSTEM

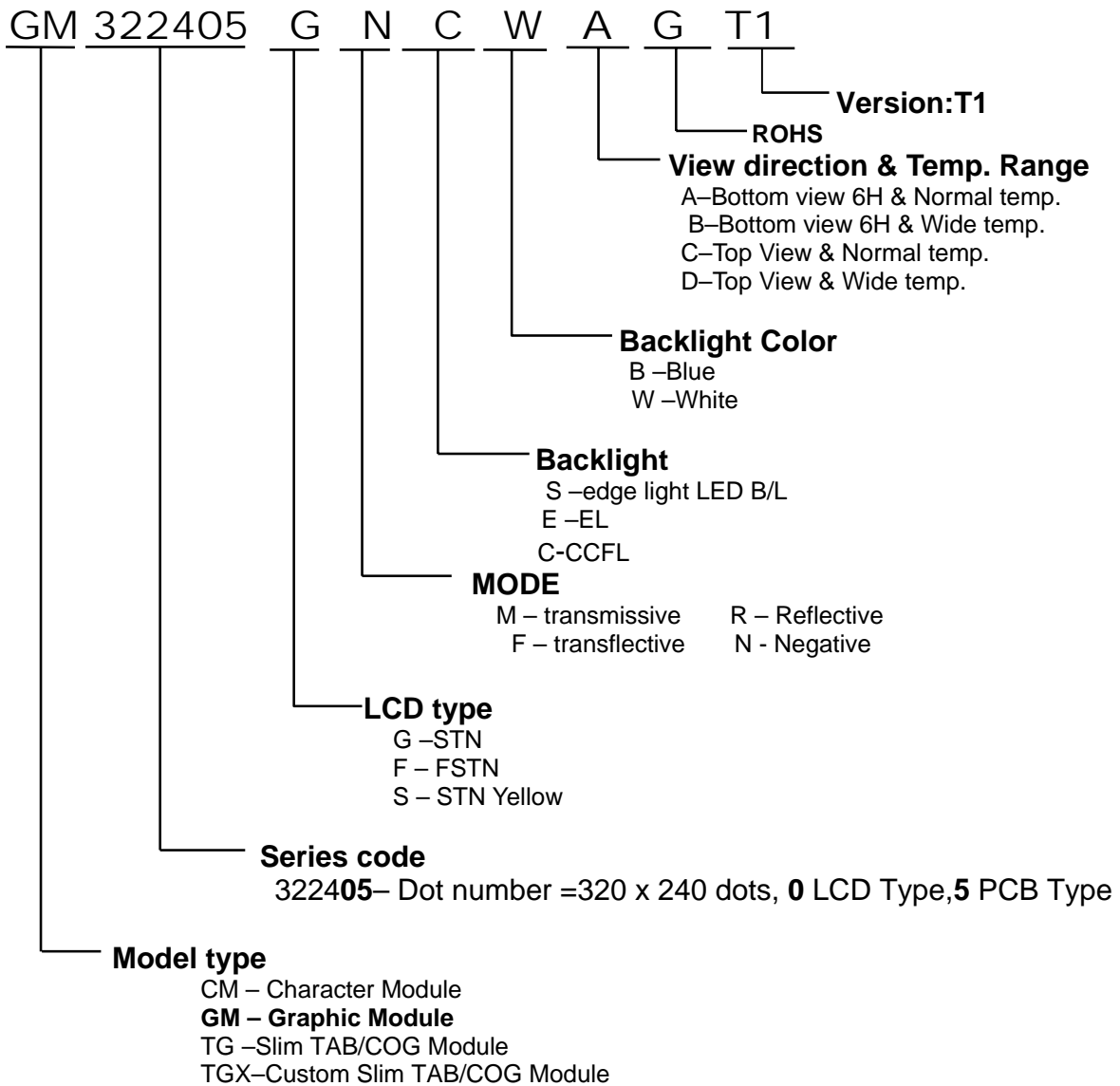

14. PRECAUTION FOR USING LCM

1. LIQUID CRYSTAL DISPLAY (LCD)

LCD is made up of glass, organic sealant, organic fluid, and polymer based polarizers. The following precautions should be taken when handling,

- (1). Keep the temperature within range of use and storage. Excessive temperature and humidity could cause polarization degradation, polarizer peel off or bubble.
- (2). Do not contact the exposed polarizers with anything harder than an HB pencil lead. To clean dust off the display surface, wipe gently with cotton, chamois or other soft material soaked in petroleum benzin.
- (3). Wipe off saliva or water drops immediately. Contact with water over a long period of time may cause polarizer deformation or color fading, while an active LCD with water condensation on its surface will cause corrosion of ITO electrodes.
- (4). Glass can be easily chipped or cracked from rough handling, especially at corners and edges.
- (5). Do not drive LCD with DC voltage.

2. Liquid Crystal Display Modules

2.1 Mechanical Considerations

LCM are assembled and adjusted with a high degree of precision. Avoid excessive shocks and do not make any alterations or modifications. The following should be noted.

- (1). Do not tamper in any way with the tabs on the metal frame.
- (2). Do not modify the PCB by drilling extra holes, changing its outline, moving its components or modifying its pattern.
- (3). Do not touch the elastomer connector, especially insert a backlight panel (for example, EL).
- (4). When mounting a LCM make sure that the PCB is not under any stress such as bending or twisting. Elastomer contacts are very delicate and missing pixels could result from slight dislocation of any of the elements.
- (5). Avoid pressing on the metal bezel, otherwise the elastomer connector could be deformed and lose contact, resulting in missing pixels.

2.2. Static Electricity

LCM contains CMOS LSI's and the same precaution for such devices should apply, namely

- (1). The operator should be grounded whenever he/she comes into contact with the module. Never touch any of the conductive parts such as the LSI pads, the copper leads on the PCB and the interface terminals with any parts of the human body.
- (2). The modules should be kept in antistatic bags or other containers resistant to static for storage.
- (3). Only properly grounded soldering irons should be used.
- (4). If an electric screwdriver is used, it should be well grounded and shielded from commutator sparks.

(5) The normal static prevention measures should be observed for work clothes and working benches; for the latter conductive (rubber) mat is recommended.

(6). Since dry air is inductive to statics, a relative humidity of 50-60% is recommended.

2.3 Soldering

- (1). Solder only to the I/O terminals.
- (2). Use only soldering irons with proper grounding and no leakage.
- (3). Soldering temperature : $280^{\circ}\text{C} \pm 10^{\circ}\text{C}$
- (4). Soldering time: 3 to 4 sec.
- (5). Use eutectic solder with resin flux fill.
- (6). If flux is used, the LCD surface should be covered to avoid flux splatters. Flux residue should be removed after wards.

2.4 Operation

- (1). The viewing angle can be adjusted by varying the LCD driving voltage V0.
- (2). Driving voltage should be kept within specified range; excess voltage shortens display life.
- (3). Response time increases with decrease in temperature.
- (4). Display may turn black or dark blue at temperatures above its operational range; this is (however not pressing on the viewing area) may cause the segments to appear "fractured".
- (5). Mechanical disturbance during operation (such as pressing on the viewing area) may cause the segments to appear "fractured".

2.5 Storage

If any fluid leaks out of a damaged glass cell, wash off any human part that comes into contact with soap and water. Never swallow the fluid. The toxicity is extremely low but caution should be exercised at all the time.

2.6 Limited Warranty

Unless otherwise agreed between DATA IMAGE and customer, DATA IMAGE will replace or repair any of its LCD and LCM which is found to be defective electrically and visually when inspected in accordance with DATA IMAGE acceptance standards, for a period on one year from date of shipment. Confirmation of such date shall be based on freight documents. The warranty liability of DATA IMAGE is limited to repair and/or replacement on the terms set forth above. DATA IMAGE will not responsible for any subsequent or consequential events.

15. OUTLINE DRAWING

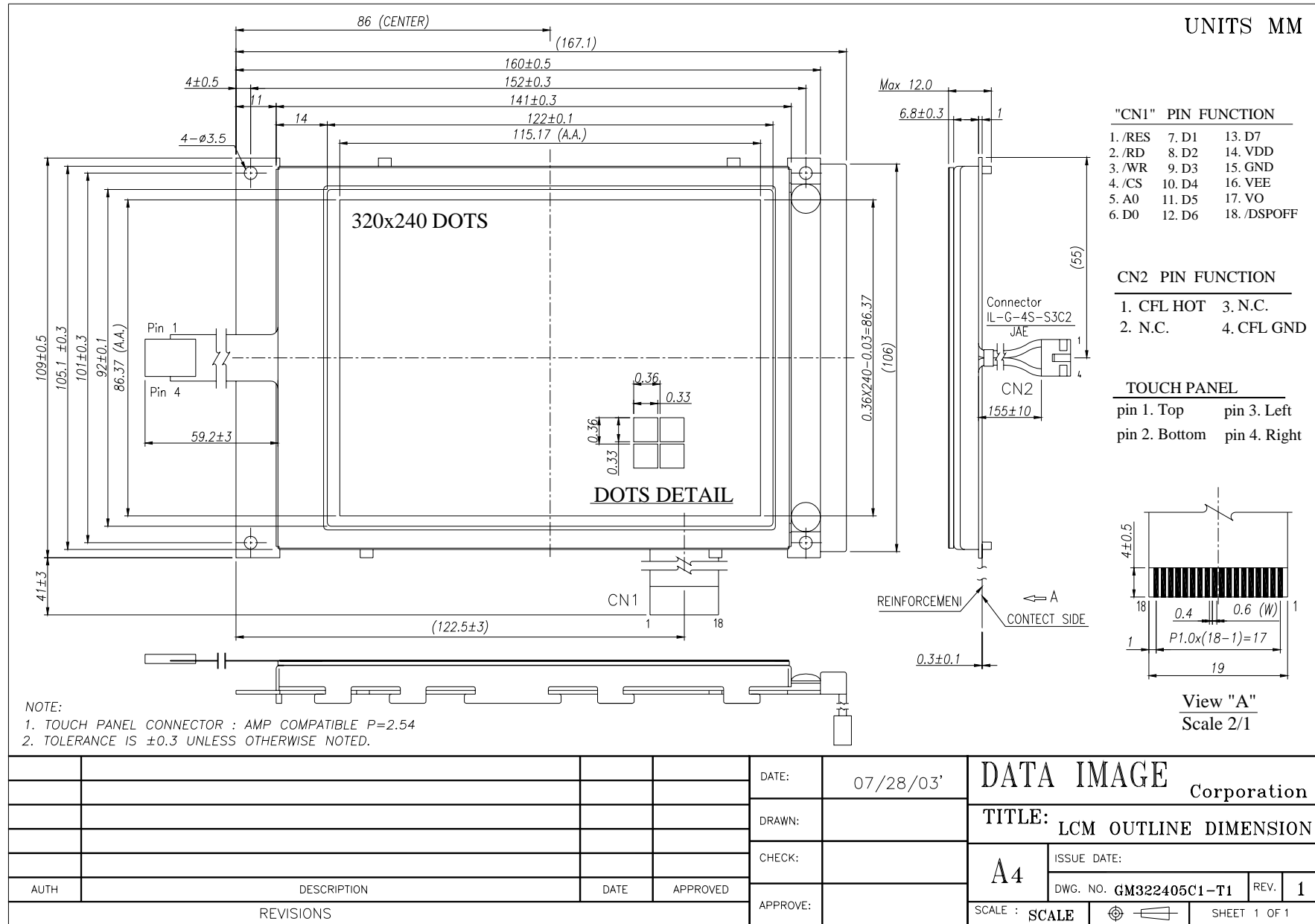

16. PACKAGE INFORMATION

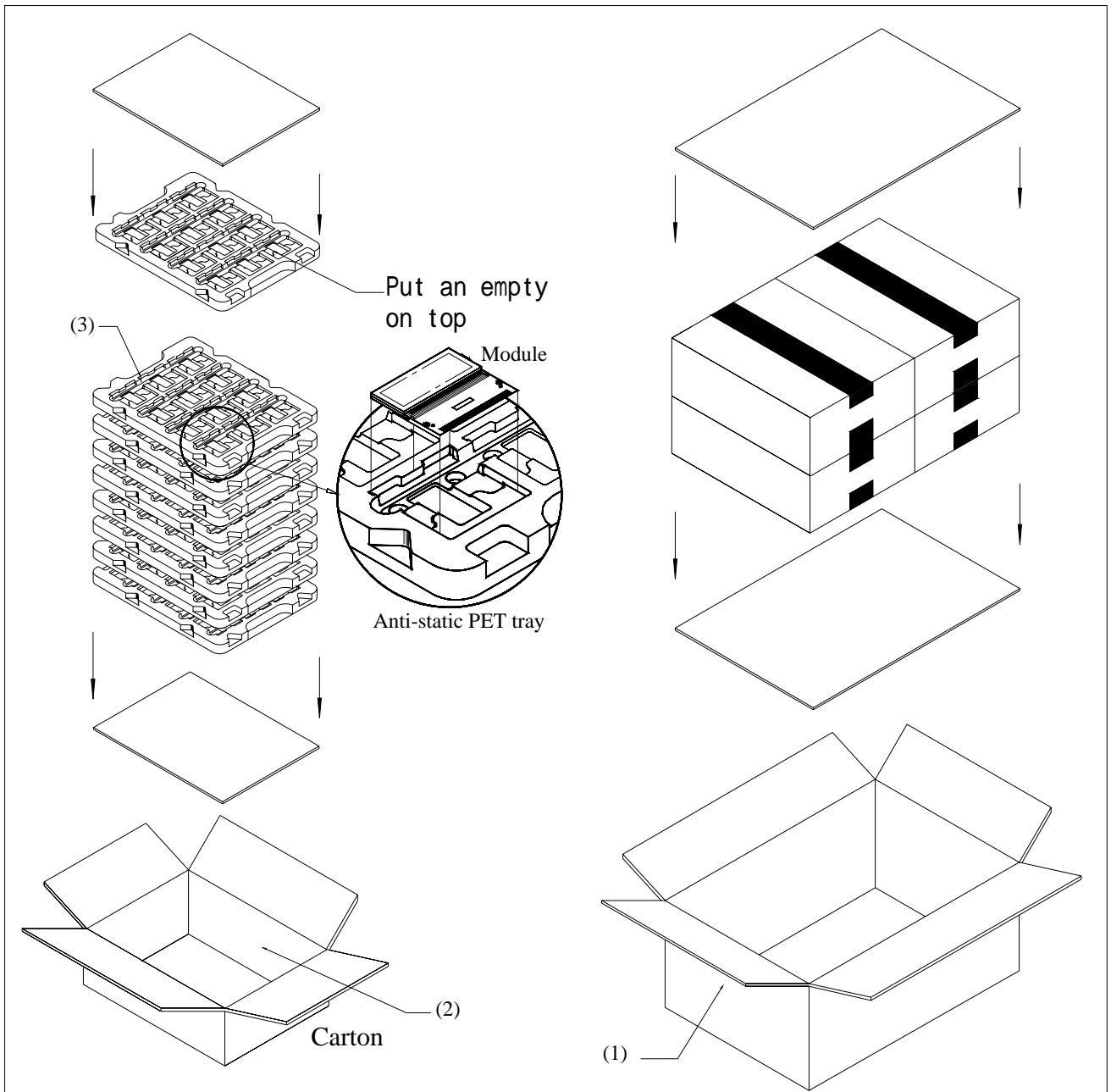

Item	Size(L*W*H)	Quantity	Note
1.Master Carton	482*282*279	1	
2.Inner Carton	267*224*115	4	
Quantity Per Inner Carton	12	Quantity per Master Carton	48
N . W	10.08 (kg)	G . W	11.08 (kg)