



Features

- 17" SXGA TFT Touch Panel PC
- 5-wire Resistive Touch Screen
- FPC-1701: Intel® 945GME/ ICH7-M Chipset
FPC-17A3: AMD RS780E/ SB710 Chipset
- VGA, DVI, Audio, 2 x 5W Speakers
- Gigabit Ethernet, Optional WiFi Module
- 1 CF, 2 COM, 5 USB
- Supports 2.5" SATA HDD
- IP-65 Compliant Front Panel
- VESA Compliance



Specifications

Model Name	FPC-1701	FPC-17A3
• LCD Size	17.0", 4:3	17.0", 4:3
• Display Type	SXGA TFT	SXGA TFT
• Resolution, Color	1280 x 1024, 16.7M	1280 x 1024, 16.7M
• Pixel Pitch	0.264mm (H) x 0.264mm (V)	0.264mm (H) x 0.264mm (V)
• Luminance	380cd/m ²	380cd/m ²
• Contrast Ratio	1000	1000
• Viewing Angle	80 (U), 85 (D), 85 (L), 85 (R)	80 (U), 85 (D), 85 (L), 85 (R)
• Response Time	5ms	5ms
• Backlight	4 x CCFL	4 x CCFL
• Touch Screen	5-wire Resistive	5-wire Resistive
• Light Transmission	80%	80%
• Touch Interface	USB	USB
System		
• CPU	Supports Intel® µFC-PGA Core™ Duo/ Core™ Solo/ Core™ 2 Duo with 65nm Process Technology	Supports AM2/ AM2+/ AM3 Socket Support 65W Athlon/ Athlon X2/ Quad-Core™ AMD Phenom™ II Processors
• Cooling Method	Active CPU Cooler	Active CPU Cooler
• System Chipset	Intel® 82945GME GMCH/ 82801GBM ICH7-M	AMD RS780E/ SB710
• I/O Chip	Winbond W83627DHG-A	FINTEK F71863FG
• System Memory	Two 240-pin DIMM Sockets Support Up to 4GB DDR2 533/667 SDRAM	Two 200-pin SODIMMs Support Up to 4GB DDR2 800 SDRAM
• SSD	One CompactFlash Type I/II Socket (Purchase from Avalue is Highly Recommended)	One CompactFlash Type I/II Socket (Purchase from Avalue is Highly Recommended)
• HDD Drive Bay	1 x 2.5" SATA HDD	1 x 2.5" SATA HDD
• Expansion	n/a	1 x Mini PCIe
Rear Panel I/O		
• Serial Port	3 x RS-232	2 x RS-232
• Ethernet	1 x RJ-45 (Realtek RTL8111B LAN)	2 x RJ-45 (Realtek RTL8111D Gigabit Ethernet)
• WiFi	Optional USB WiFi 802.11 b/g (Occupies One USB Port)	Optional USB WiFi 802.11 b/g (Occupies One USB Port)
• VGA	1 x DB-15	1 x DB-15
• DVI	1 x DVI	n/a
• HDMI	n/a	1 x HDMI
• Audio	Line-out, Line-in, Mic-in	Line-out, Line-in, Mic-in
• USB	5 x USB 2.0	5 x USB 2.0
• Mouse & K/B	1 x PS/2 Keyboard Connector	1 x PS/2 Keyboard Connector
• Speaker	2 x 5W	2 x 5W



Diagram

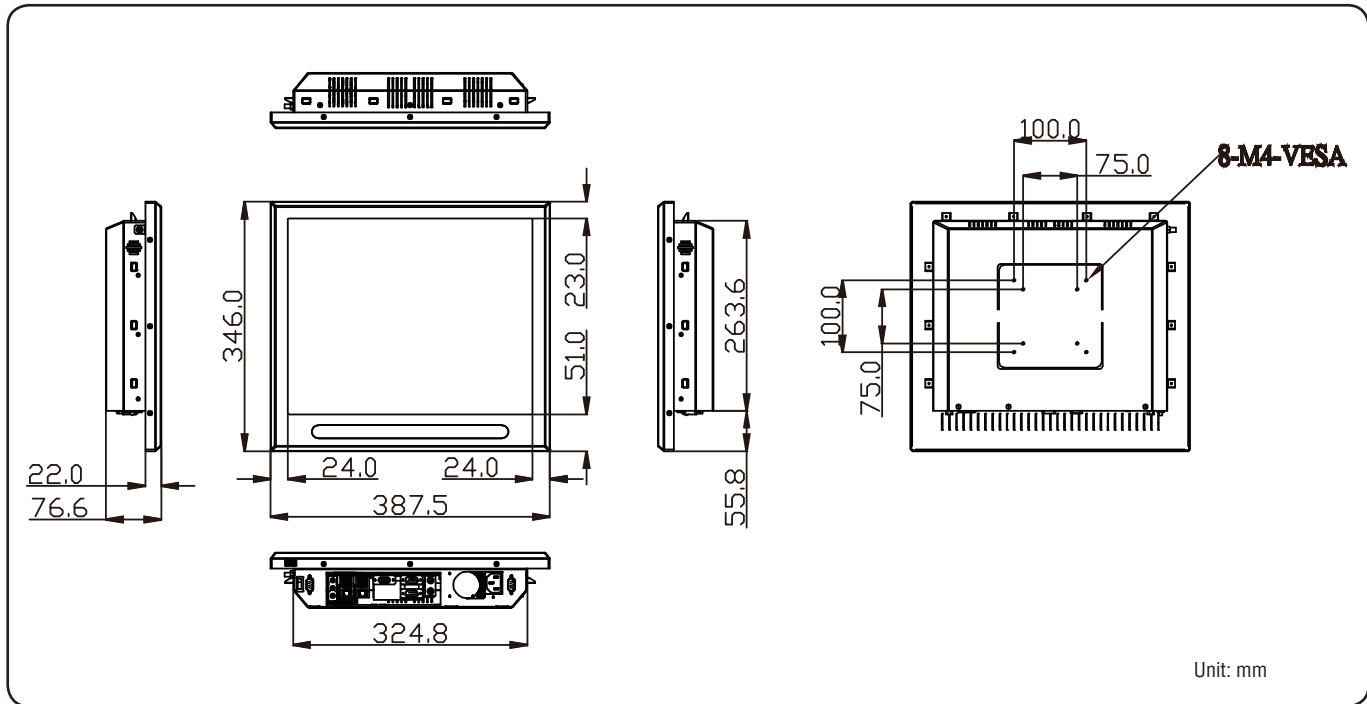

Environment & Mechanical

• System Fan	1 x System Fan
• Color	Front Panel Black; Rear Panel Black
• Mounting	Wall/ Stand/ VESA 75mm x 75mm and 100mm x 100mm
• Power Input	100 ~ 240VAC
• Power Output	180W
• Operating Temperature	0°C ~ 40°C (32°F ~ 104°F)
• Storage Temperature	-10°C ~ 50°C (14°F ~ 122°F)
• Relative Humidity	10% to 95% @ 40°C, Non-condensing
• Dimension (W x D x H)	387.5mm X 346mm X 76.6mm
• Weight	6.14Kgs

Ordering Information

- **FPC-1701**
17" SXGA TFT Touch Panel PC with Intel® 945GME Chipset, 5-wire Resistive Touch Panel
- **FPC-17A3**
17" SXGA TFT Touch Panel PC with AMD RS780E Chipset, 5-wire Resistive Touch Panel
- **ACC-WIFI-USB-5R**
VNT6656G6A40-OE + PL99G26-130011 (ANTENNA)
- **ACC-WIFI-USB-11R**
USB 802.11b/g/n WiFi Module (1T1R)
- **ACC-FPC-WALLMT-03R**
Wall Mount Bracket Kit for FPC-17~21W B1
- **ACC-FPC-WALLMT-04R**
Openframe Bracket Kit for FPC-17 Series B1
- **ACC-ARM-D23R**
VESA Stand, 75 & 100mm
- **ACC-CF-XX**
CompactFlash Card Series (xx=Capacity, Capacity Option: 128, 256, 512MB, 1, 2, 4, 8GB)

- 1 LPC Series
- 2 PPC Series
- 3 **FPC Series**
- 4 MPC Series
- 5 SPC Series
- 6 MTP Series
- 7 OPC/LCD Kit
- 8 RISC
- 9 ACC