



DATA IMAGE CORPORATION

TFT Module Specification

Preliminary

ITEM NO.: FG0700M1DSSWMG01

Table of Contents

1. COVER & CONTENTS	1
2. RECORD OF REVISION	2
3. APPLICATION.....	3
4. GENERAL SPECIFICATIONS	3
5. ABSOLUTE MAXIMUM RATINGS	3
6. ELECTRICAL CHARACTERISTICS	3
7. TIMING SPECIFICATIONS	5
8. OPTICAL CHARACTERISTIC	8
9. PIN CONNECTIONS	11
10. BLOCK DIAGRAM	13
11. QUALITY ASSURANCE	14
12. LCM PRODUCT LABEL DEFINE.....	15
13. PRECAUTIONS IN USE LCM	17
14. OUTLINE DRAWING	18
15. PACKAGE INFORMATION.....	19

Customer Companies	R&D Dept.	Q.C. Dept.	Eng. Dept.	Prod. Dept.
	JACK	ERIC	PAUL	HELEN
Approved by	Version:	Issued Date:	Sheet Code:	Total Pages:
	2	22/SEP/11'		19

2. RECORD OF REVISION

Rev	Date	Item	Page	Comment
1	8/NOV/10'			Initial PRELIMINARY
2	22/SEP/11'	4	3	1. Modify the Surface treatment & add weight.
		6	3	2. Modify the Power Supply Current (I_{CC}).
		13	17	3. Modify PRECAUTIONS IN USE LCM

3. APPLICATION

DVD player, Car TV, UMPC, POS

4. GENERAL SPECIFICATIONS

Parameter	Specifications	Unit
Screen Size	7 (diagonal)	inch
Display Format	800(H) x (R,G,B) x 480(V)	dot
Active Area	152.4(H) x 91.44(V)	mm
Dot Pitch	0.0635 (H) x 0.1905 (V)	mm
Pixel Configuration	Stripe	
Outline Dimension	165(W) x 104(H) x 4.2(D)	mm
Surface treatment	Glare	
Back-light	LED	
Display mode	Normally Black	
Weight	110	g
View Angle direction	Wide View	

5. ABSOLUTE MAXIMUM RATINGS

Parameter	Symbol	MIN.	MAX.	Unit	Remark
Power supply voltage	V _{CC}	-0.3	5.0	V	Ta=25°C
Logic input voltage	V _I	-0.3	V _{CC} +0.3	V	
Operating temperature	T _{op}	-20	70	°C	Module surface*
Storage temperature	T _{st}	-30	80	°C	-
Humidity	Operation	20%~90% relative humidity			Ta<=38°C
	Non Operation	5%~90% relative humidity			Ta<=38°C

6. ELECTRICAL CHARACTERISTICS

f_H=30KHz, f_V=60Hz, f_{CLK}=27MHz, Ta=25°C

Parameter	Symbol	MIN.	Typ.	MAX.	Unit	Remark
Power Supply voltage for LCD	V _{CC}	+3.0	+3.3	+3.6	V	
Power Supply Current for LCD	I _{CC}		220	300	mA	V _{CC} =3.3V
Power Supply voltage for LED	V _{DD}	3.0	3.3	5.5	V	
Power Supply Current for LED	I _{DD}		650	850	mA	V _{DD} =3.3V
	I _{DD}		400	550	mA	V _{DD} =5.0V
Ripple voltage	V _{RF}	-	-	100	mV _{P-P}	
Differential Input High Threshold	V _{TH}	-	-	100	[mV]	V _{CM} =1.2V Note 1
Differential input Low Threshold	V _{TL}	-100	-	-	[mV]	
ADJ frequency		19K	20K	21K	Hz	
ADJ input voltage	V _{IH}	3.0	-	3.3	V	
	V _{IL}	0	-	0.3	V	
LED dice life time		20000	30000		Hr	Note 2

Note 1: LVDS Signal Waveform.

Differential Signal

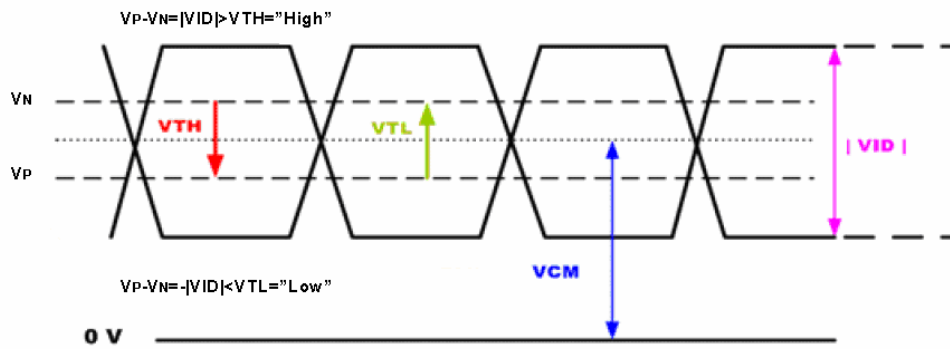

Note 2: The "LED dice life time" is defined as the brightness decrease to 50% original brightness that the ambient temperature is $18^{\circ}C \sim 28^{\circ}C$ and LED dice current=20mA.

7. TIMING SPECIFICATIONS

ITEM		SYMBOL	MIN.	TYP.	MAX.	UNIT
DCLK	Period	t_{CLK}	31	37.0	40.0	ns
	Dot Clock	f_{CLK}	25	27	32.11	MHz
	Low Level Width	t_{WCL}	8	-	-	ns
	High Level Width	t_{WCH}	8	-	-	
DE	Setup Time	t_{DES}	5	-	-	ns
	Hold time	t_{DEH}	10	-	-	
	Horizontal Period	t_{HP}	850	900	950	
	Horizontal Valid	t_{HV}	800			
	Horizontal Blank	t_{HBK}	50	100	150	
	Vertical Period	t_{VP}	490	500	520	t_{HP}
	Vertical Valid	t_{VV}	480			
	Vertical Blank	t_{VBK}	10	20	40	
	Vertical Frequency	f_V	55	60	65	
DATA	Setup Time	t_{DS}	5	-	-	ns
	Hold Time	t_{DH}	10	-	-	

Note: High level of T-CON logic signal is 80%
 Low level of T-CON logic signal is 20%

7.1 TIMING CHARACTERISTIC :

7.1.1 TTL Timing Chart

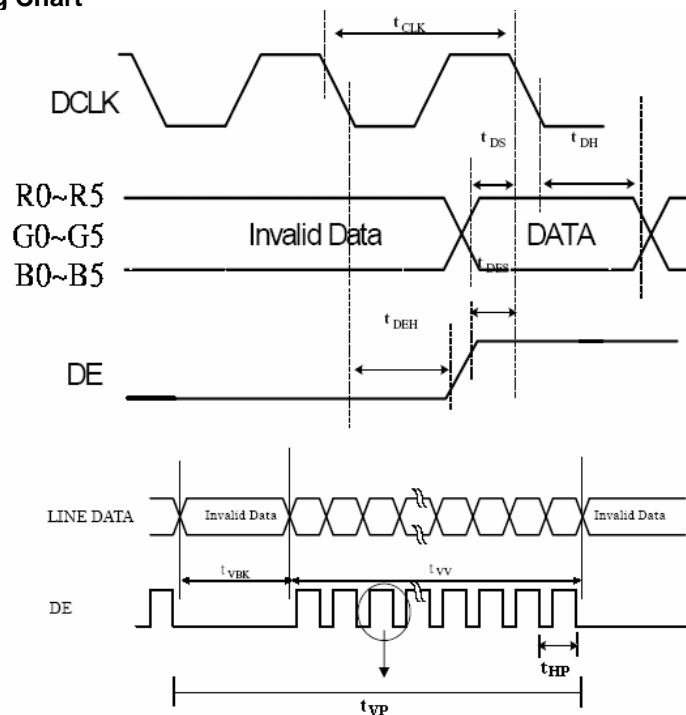

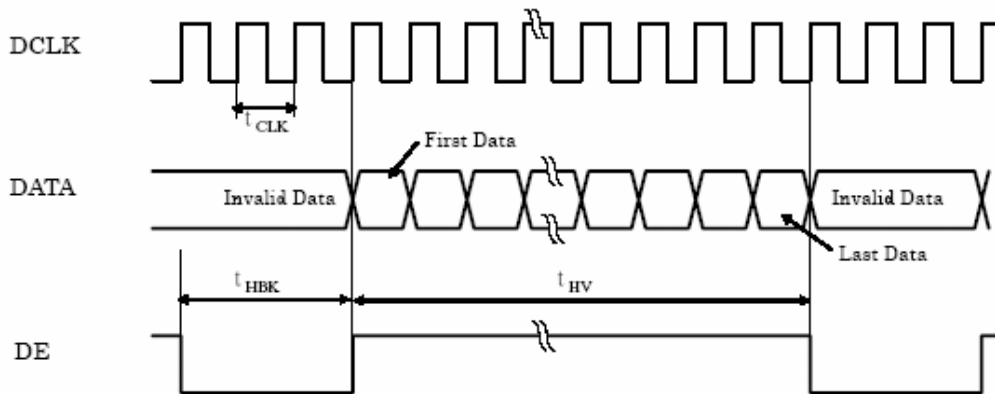

7.1.2 LVDS Timing Chart

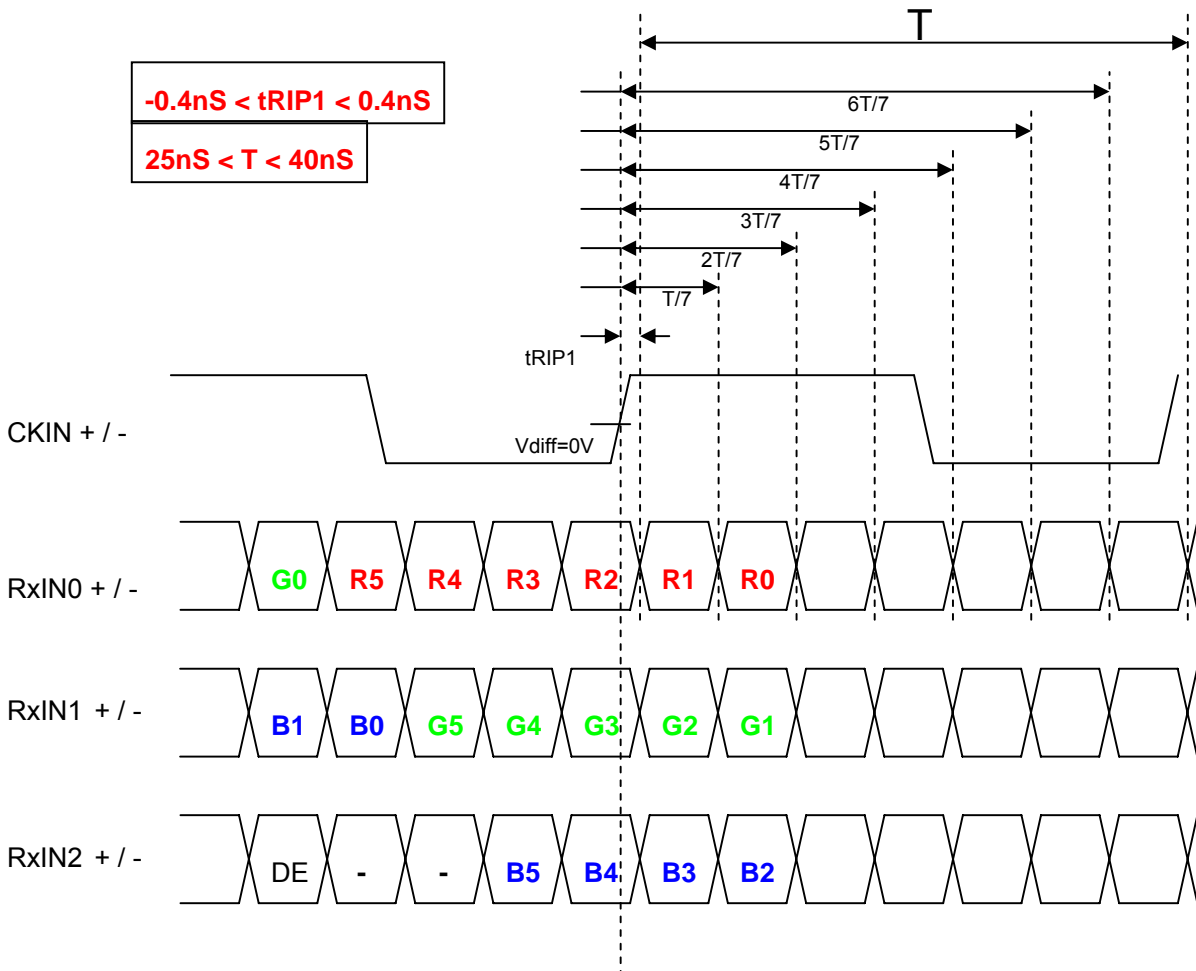

7.2 Color Data Input Assignment

		Data Signal																	
		Red					Green					Blue							
Color		R5	R4	R3	R2	R1	R0	G5	G4	G3	G2	G1	G0	B5	B4	B3	B2	B1	B0
Basic Colors	Black	0	0	0	0	0	0	0	0	0	0	0	0	0	0	0	0	0	0
	Red	1	1	1	1	1	1	0	0	0	0	0	0	0	0	0	0	0	0
	Green	0	0	0	0	0	0	1	1	1	1	1	1	0	0	0	0	0	0
	Blue	0	0	0	0	0	0	0	0	0	0	0	0	1	1	1	1	1	1
	Cyan	0	0	0	0	0	0	1	1	1	1	1	1	1	1	1	1	1	1
	Magenta	1	1	1	1	1	1	0	0	0	0	0	0	1	1	1	1	1	1
	Yellow	1	1	1	1	1	1	1	1	1	1	1	1	0	0	0	0	0	0
	White	1	1	1	1	1	1	1	1	1	1	1	1	1	1	1	1	1	1
	Gray Scale of Red	Red(0) / Dark	0	0	0	0	0	0	0	0	0	0	0	0	0	0	0	0	0
Red(1)		0	0	0	0	0	1	0	0	0	0	0	0	0	0	0	0	0	0
Red(2)		0	0	0	0	1	0	0	0	0	0	0	0	0	0	0	0	0	0
:		:	:	:	:	:	:	:	:	:	:	:	:	:	:	:	:	:	:
:		:	:	:	:	:	:	:	:	:	:	:	:	:	:	:	:	:	:
Red(61)		1	1	1	1	0	1	0	0	0	0	0	0	0	0	0	0	0	0
Red(62)		1	1	1	1	1	0	0	0	0	0	0	0	0	0	0	0	0	0
Red(63)		1	1	1	1	1	1	0	0	0	0	0	0	0	0	0	0	0	0
Gray Scale of Green	Green(0)/ Dark	0	0	0	0	0	0	0	0	0	0	0	0	0	0	0	0	0	0
	Green(1)	0	0	0	0	0	0	0	0	0	0	0	1	0	0	0	0	0	0
	Green(2)	0	0	0	0	0	0	0	0	0	0	1	0	0	0	0	0	0	0
	:	:	:	:	:	:	:	:	:	:	:	:	:	:	:	:	:	:	:
	:	:	:	:	:	:	:	:	:	:	:	:	:	:	:	:	:	:	:
	Green(61)	0	0	0	0	0	0	1	1	1	1	0	1	0	0	0	0	0	0
	Green(62)	0	0	0	0	0	0	1	1	1	1	1	0	0	0	0	0	0	0
	Green(63)	0	0	0	0	0	0	1	1	1	1	1	1	0	0	0	0	0	0
Gray Scale of Blue	Blue(0)/ Dark	0	0	0	0	0	0	0	0	0	0	0	0	0	0	0	0	0	0
	Blue (1)	0	0	0	0	0	0	0	0	0	0	0	0	0	0	0	0	0	1
	Blue (2)	0	0	0	0	0	0	0	0	0	0	0	0	0	0	0	0	1	0
	:	:	:	:	:	:	:	:	:	:	:	:	:	:	:	:	:	:	:
	:	:	:	:	:	:	:	:	:	:	:	:	:	:	:	:	:	:	:
	Blue (61)	0	0	0	0	0	0	0	0	0	0	0	0	1	1	1	1	0	1
	Blue (62)	0	0	0	0	0	0	0	0	0	0	0	0	1	1	1	1	1	0
	Blue (63)	0	0	0	0	0	0	0	0	0	0	0	0	1	1	1	1	1	1

Correspondence between Data and Display Position

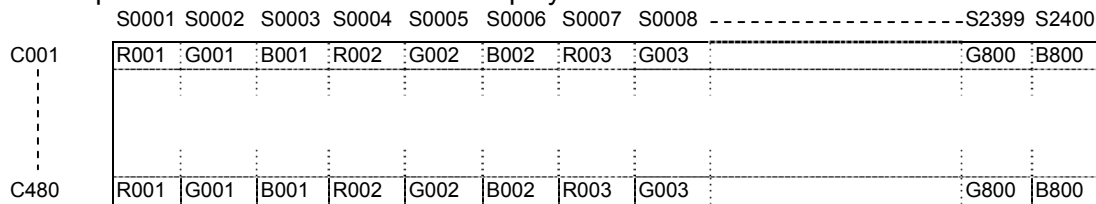

8. OPTICAL CHARACTERISTIC

Parameter		Symbol	Condition	MIN.	TYP.	MAX.	Unit	Remarks
Viewing Angle	Horizontal	θ_{x+}	Center CR \geq 10	70	80	--	deg	Note 1,4
		θ_{x-}		70	80	--		
	Vertical	θ_{y+}		70	80	--		
		θ_{y-}		70	80	--		
Contrast Ratio		CR	at optimized viewing angle	300	400			Note 1,3
Response time	Rise	Tr	Center	-	20	--	ms	Note 1,6
	Fall	Tf	$\theta_x=\theta_y=0^\circ$	-	10	--	ms	
Uniformity		B-uni	$\theta_x=\theta_y=0^\circ$	70	80	--	%	Note1,5
Brightness		L	$\theta_x=\theta_y=0^\circ$ ADJ=3.3V	320	400	--	cd/m ²	Note 1,2
Chromaticity		x_W	Center $\theta_x=\theta_y=0^\circ$	0.257	0.307	0.357		Note 1,7
		y_W		0.289	0.339	0.389		
		x_R		0.552	0.602	0.652		
		y_R		0.304	0.354	0.404		
		x_G		0.305	0.352	0.402		
		y_G		0.525	0.575	0.625		
		x_B		0.094	0.144	0.194		
		y_B		0.049	0.0979	0.149		
Image sticking		tis	2 hours			2	Sec	Note 8

The following optical specifications shall be measured in a darkroom or equivalent state (ambient luminance \leq 1 lux, and at room temperature). The operation temperature is 25°C \pm 2°C. The measurement method is shown in Note1.

Note1: The method of optical measurement:

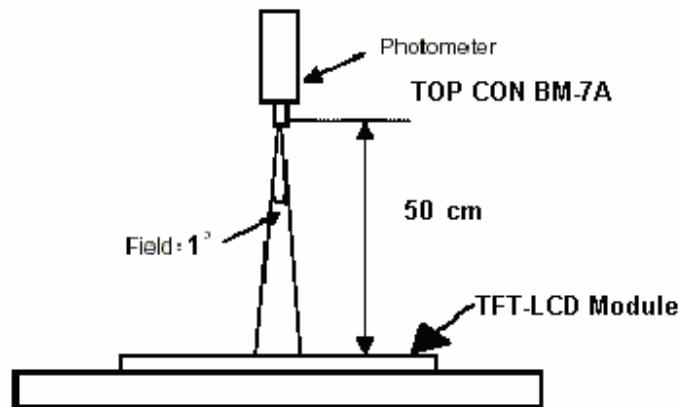

Note2: Measured at the center area of the panel and at the viewing angle of the $\theta_x = \theta_y = 0^\circ$

Note3: Definition of Contrast Ratio (CR):

$$CR = \frac{\text{Luminance with all pixels in white state}}{\text{Luminance with all pixels in Black state}}$$

Note4: Definition of Viewing Angle

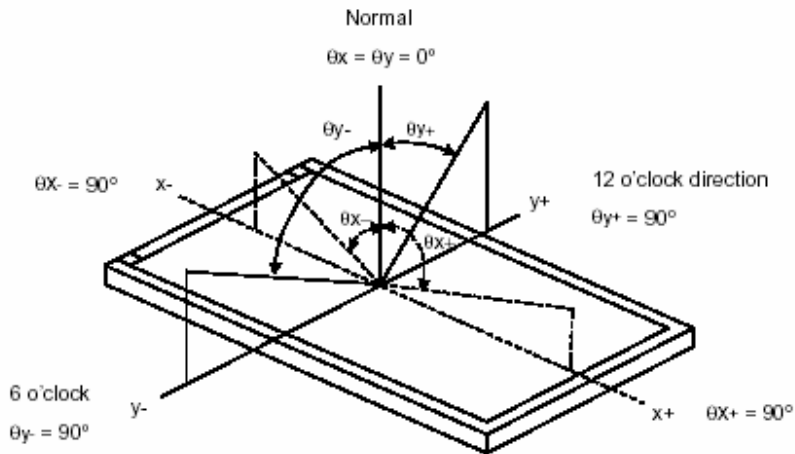

Note 5: Definition of Brightness Uniformity (B-uni):

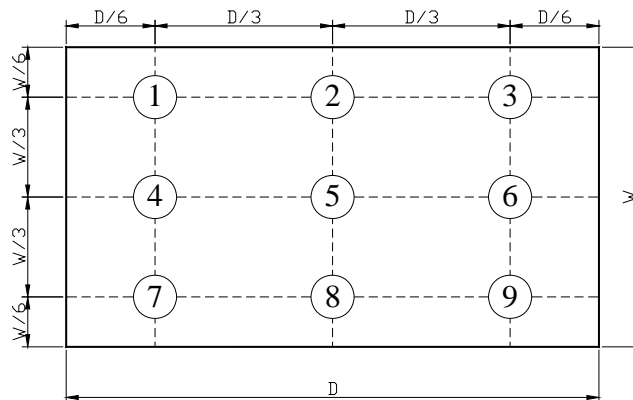

$$B\text{-uni} = \frac{\text{Minimum luminance of 9 points}}{\text{Maximum luminance of 9 points}} \quad (\text{Note 5}).$$

Note6: Definition of Response Time:

The Response Time is set initially by defining the “Rising Time (T_r)” and the “Falling Time (T_f)” respectively. T_r and T_f are defined as following figure.

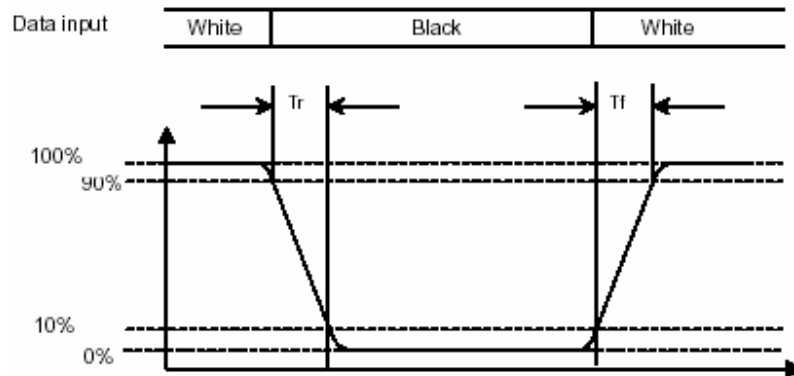

Note 7: Definition of Chromaticity:

The color coordinates (x_w, y_w) , (x_r, y_r) , (x_g, y_g) , and (x_b, y_b) are obtained with all pixels in the viewing field at white, red, green, and blue states, respectively.

Note 8: Definition of Image sticking (tis):

Continuously display the test pattern shown in the figure below for 2 hours. Then display a completely white screen. The previous image shall not persist more than 2 sec at 25 °C

Image sticking pattern

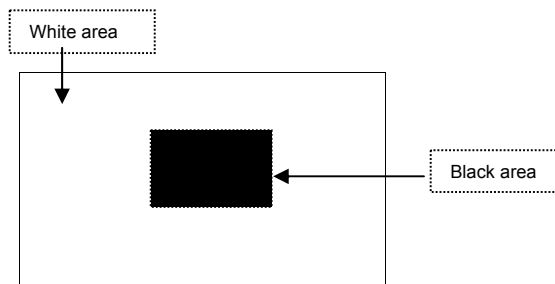

9. PIN CONNECTIONS

Pin No	Symbol	Function	Remark
1	VCC	power supply for Digital Circuit	
2	VCC	power supply for Digital Circuit	
3	GND	Ground	
4	GND	Ground	
5	RxIN0-	Differential Data Input ,CH0(Negative)	
6	RxIN0+	Differential Data Input ,CH0(Positive)	
7	GND	Ground	
8	RxIN1-	Differential Data Input ,CH1(Negative)	
9	RxIN1+	Differential Data Input ,CH1(Positive)	
10	GND	Ground	
11	RxIN2-	Differential Data Input ,CH2(Negative)	
12	RxIN2+	Differential Data Input ,CH2(Positive)	
13	GND	Ground	
14	CKIN-	Differential Clock Input (Negative)	
15	CKIN+	Differential Clock Input (Positive)	
16	GND	Ground	
17	VDD	Power Supply for LED Driver Circuit	
18	VDD	Power Supply for LED Driver Circuit	
19	GND	Ground	
20	ADJ	Brightness control for LED B/L	

Remarks :

- 1) ADJ is brightness control Pin. The larger of the pulse duty is, the higher of the brightness.
- 2) ADJ signal is 0~3.3V. Operation frequency is 20KHz
- 3) GND PIN must be grounding, can not be floating.

Remarks:

Power Signal sequence:

$t1 \leq 10\text{ms}$; $1 \text{ sec} \leq t5$

$50\text{ms} \leq t2$; $200\text{ms} \leq t6$

$0 < t3 \leq 50\text{ms}$; $200\text{ms} \leq t7$

$0 < t4 \leq 10\text{ms}$

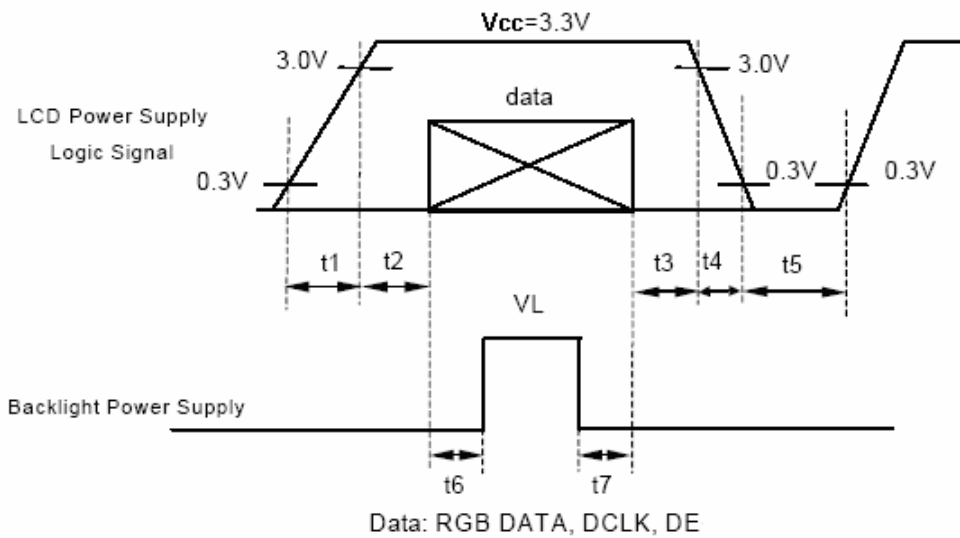

VCC-dip condition:

(1) $2.7 \text{ V} \leq V_{CC} < 3.0\text{V}$, $t_d \leq 10 \text{ ms}$

(2) $V_{CC} > 3.0\text{V}$, VCC-dip condition should be the same with VCC-turn-on condition ◦

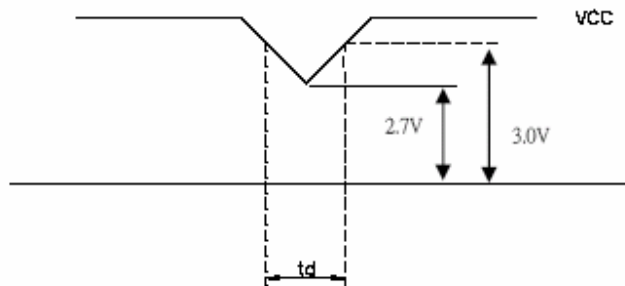

10. BLOCK DIAGRAM

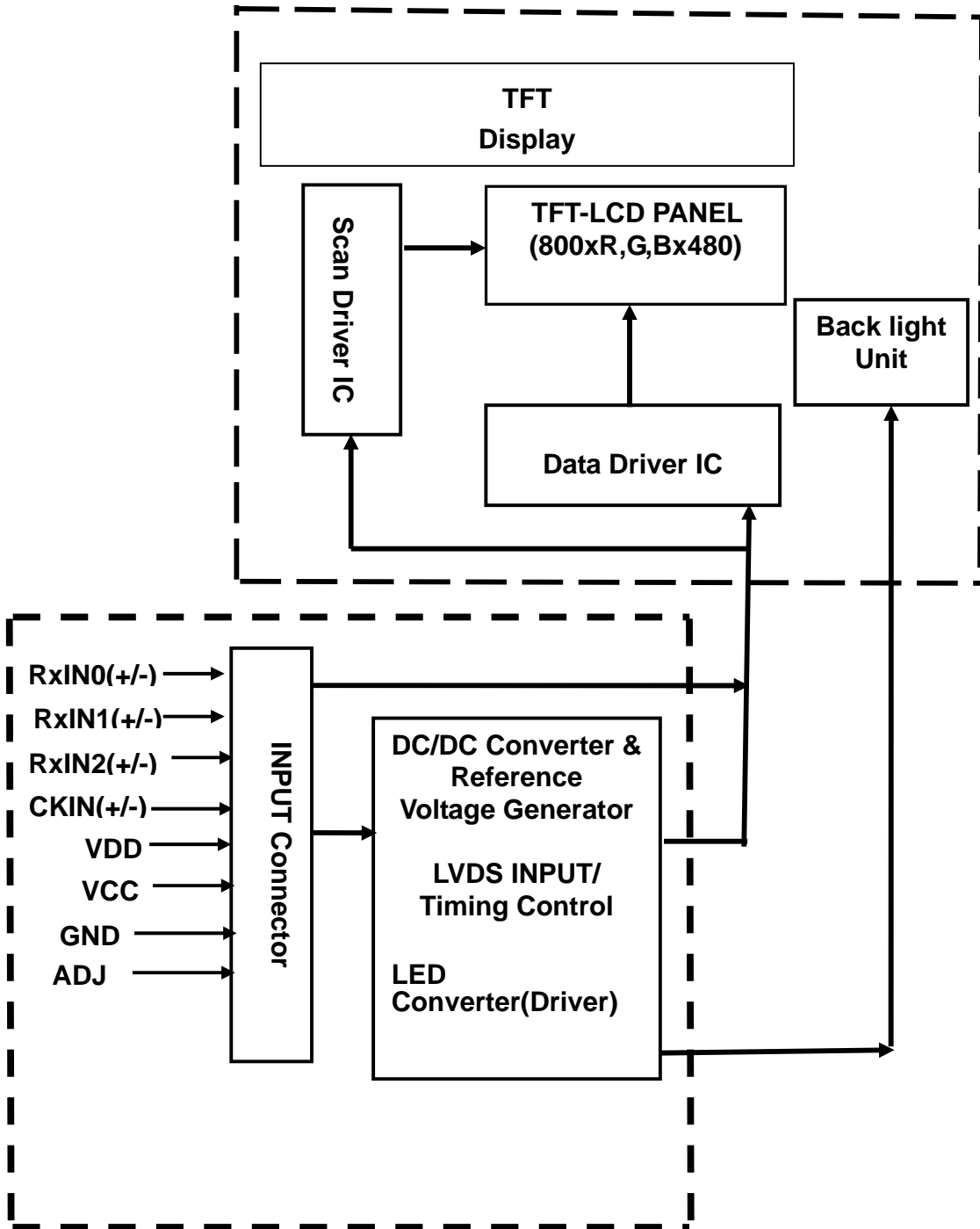

11. QUALITY ASSURANCE

11.1 Test Condition

11.1.1 Temperature and Humidity(Ambient Temperature)

Temperature : $25 \pm 5^{\circ}\text{C}$

Humidity : $65 \pm 5\%$

11.1.2 Operation

Unless specified otherwise, test will be conducted under function state.

11.1.3 Container

Unless specified otherwise, vibration test will be conducted to the product itself without putting it in a container.

11.1.4 Test Frequency

In case of related to deterioration such as shock test. It will be conducted only once.

11.1.5 Test Method

Reliability Test Item & Level		Test Level
No.	Test Item	
1	High Temperature Storage Test	T=80°C,240hrs
2	Low Temperature Storage Test	T=-30°C,240hrs
3	High Temperature Operation Test	T=70°C,240hrs
4	Low Temperature Operation Test	T=-20°C,240hrs
5	High Temperature and High Humidity Operation Test	T=60°C,90%RH,240hrs
6	Thermal Cycling Test (No operation)	-30°C → +25°C → +80°C, 100 Cycles 30 min 5 min 30 min
7	Vibration Test (No operation)	Frequency :10 ~ 55 Hz Amplitude :1.5 mm Sweep time : 11 mins Test Period: 6 Cycles for each direction of X, Y, Z

11.2 Judgment standard

The Judgment of the above test should be made after exposure in room temperature for two hours as follow:

Pass: Normal display image with no obvious non-uniformity and no line defect. Partial transformation of the module parts should be ignored.

Fail: No display image, obvious non-uniformity, or line defect.

12. LCM PRODUCT LABEL DEFINE

Product Label style:

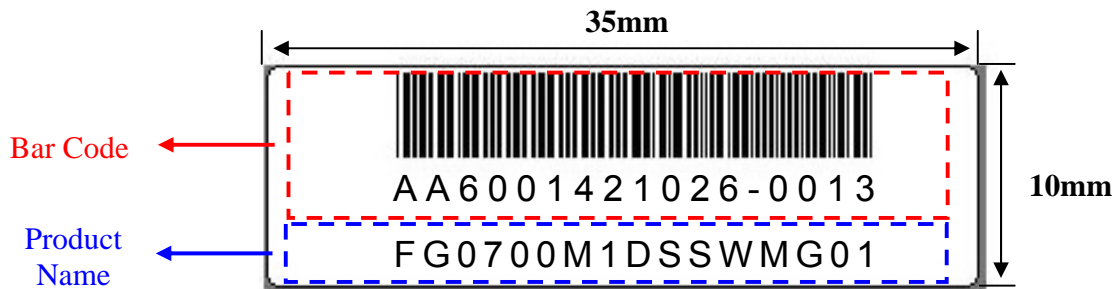

BarCode Define:

A A 6 0014 2 10 26-0013

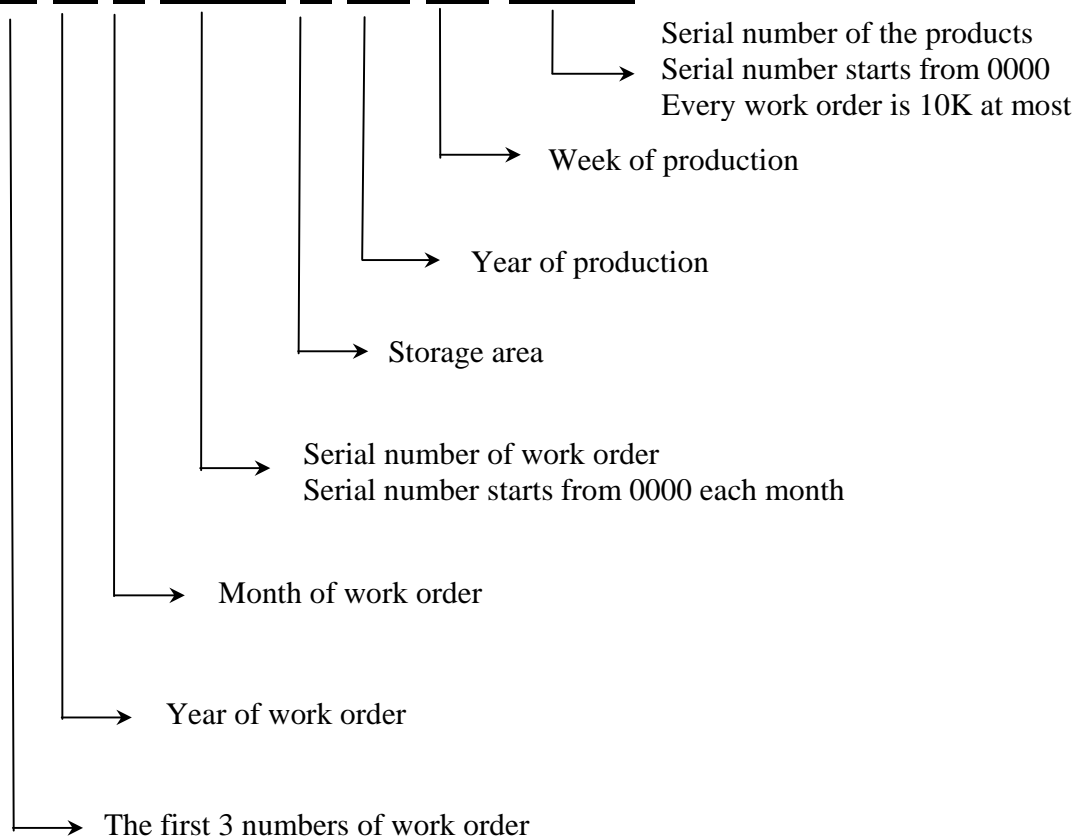

Product Name Define:

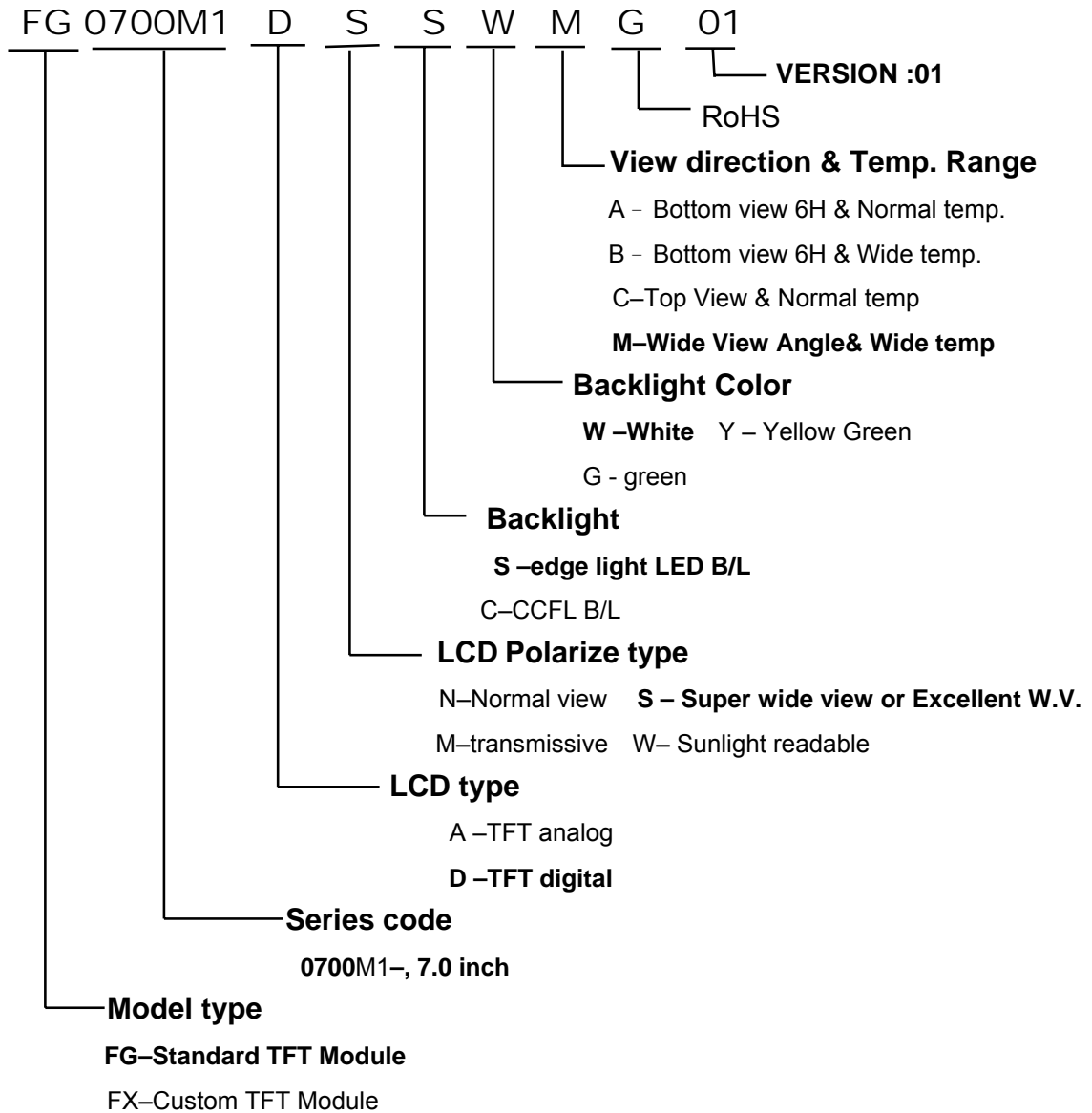

13. PRECAUTIONS IN USE LCM

1. ASSEMBLY PRECAUTIONS

- (1) You must mount a module using holes arranged in four corners or four sides.
- (2) You should consider the mounting structure so that uneven force (ex. Twisted stress) is not applied to the module. And the case on which a module is mounted should have sufficient strength so that external force is not transmitted directly to the module.
- (3) Do not touch, push or rub the exposed polarizers with glass, tweezers or anything harder than HB pencil lead. And please do not rub with dust clothes with chemical treatment.
- (4) Wipe off saliva or water drops as soon as possible. Their long time contact with polarizer causes deformations and color fading.
- (5) Do not open the case because inside circuits do not have sufficient strength.
- (6) Please do not take a LCD module to pieces and reconstruct it. Resolving and reconstructing modules may cause them not to work well.
- (7) Please do not touch metal frames with bare hands and soiled gloves. A color change of the metal frames can happen during a long preservation of soiled LCD modules.
- (8) Please pay attention to handling lead wire of backlight so that it is not tugged in connecting with inverter.

2. OPERATING PRECAUTIONS

- (1) Please be sure to turn off the power supply before connecting and disconnecting signal input cable.
- (2) Please do not change variable resistance settings in LCD module. They are adjusted to the most suitable value. If they are changed, it might happen LCD does not satisfy the characteristics specification
- (3) Be careful for condensation at sudden temperature change. Condensation makes damage to polarizer or electrical contacted parts. And after fading condensation, smear or spot will occur.
- (4) When fixed patterns are displayed for a long time, remnant image is likely to occur.
- (5) Module has high frequency circuits. Sufficient suppression to the electromagnetic interference shall be done by system manufacturers. Grounding and shielding methods may be important to minimize the interference.
- (6) Please consider that LCD backlight takes longer time to become stable of radiation characteristics in low temperature than in room temperature.

3. ELECTROSTATIC DISCHARGE CONTROL

- (1) The operator should be grounded whenever he/she comes into contact with the module. Never touch any of the conductive parts such the copper leads on the PCB and the interface terminals with any parts of the human body.

- (2) The modules should be kept in antistatic bags or other containers resistant to static for storage.
- (3) Only properly grounded soldering irons should be used.
- (4) If an electric screwdriver is used, it should be well grounded and shielded from commutator sparks.
- (5) The normal static prevention measures should be observed for work clothes and working benches; for the latter conductive (rubber) mat is recommended
- (6) Since dry air is inductive to statics, a relative humidity of 50-60% is recommended.

4. STORAGE PRECAUTIONS

- (1) When you store LCDs for a long time, it is recommended to keep the temperature between 0°C-40°C without the exposure of sunlight and to keep the humidity less than 90%RH.
- (2) Please do not leave the LCDs in the environment of high humidity and high temperature such as 60°C 90%RH
- (3) Please do not leave the LCDs in the environment of low temperature; below -20°C.

5. OTHERS

- (1) A strong incident light into LCD panel might cause display characteristics' changing inferior because of polarizer film, color filter, and other materials becoming inferior. Please do not expose LCD module direct sunlight and strong UV rays
- (2) Please pay attention to a panel side of LCD module not to contact with other materials in preserving it alone.
- (3) For the packaging box, please pay attention to the followings:
 - a. Please do not pile them up more than 5 boxes. (They are not designed so.) And please do not turn over.
 - b. Please handle packaging box with care not to give them sudden shock and vibrations. And also please do not throw them up.
 - c. Packing box and inner case for LCDs are made of cardboard. So please pay attention not to get them wet. (Such like keeping them in high humidity or wet place can occur getting them wet.)

6. LIMITED WARRANTY

Unless otherwise agreed between DATA IMAGE and customer, DATA IMAGE will replace or repair any of its LCD and LCM which is found to be defective electrically and visually when inspected in accordance with DATA IMAGE acceptance standards, for a period on one year from date of shipment. Confirmation of such date shall be based on freight documents. The warranty liability of DATA IMAGE is limited to repair and/or replacement on the terms set forth above. DATA IMAGE will not responsible for any subsequent or consequential events.

Confidential Document
14. OUTLINE DRAWING

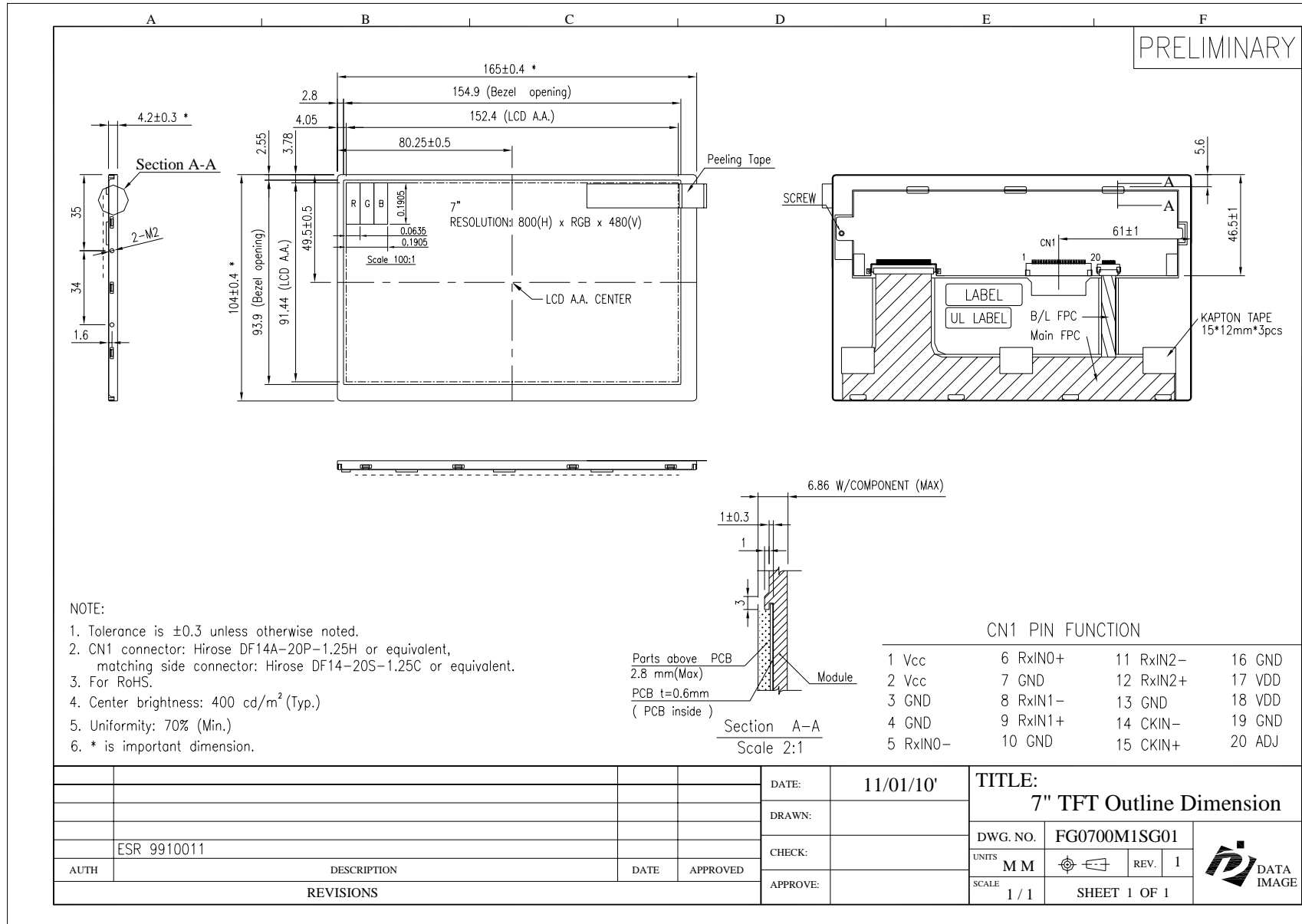

15.PACKAGE INFORMATION

TBD