



DATA IMAGE CORPORATION

TFT Module Specification Preliminary

ITEM NO.: FG0700K4DSSWBG01

Table of Contents

1. COVER & CONTENTS	1
2. RECORD OF REVISION	2
3. APPLICATION.....	3
4. GENERAL SPECIFICATIONS	3
5. ABSOLUTE MAXIMUM RATINGS	3
6. ELECTRICAL CHARACTERISTICS	4
7. INTERFACE SPECIFICATIONS	5
8. OPTICAL CHARACTERISTIC	7
9. PIN CONNECTIONS	10
10. BLOCK DIAGRAM	12
11. APPLICATION CIRCUIT.....	13
12. QUALITY ASSURANCE	14
13. LOT NUMBERING SYSTEM	15
14. LCM NUMBERING SYSTEM	15
15. PRECAUTIONS IN USE LCM	16
16. OUTLINE DRAWING	17
17. PACKAGE INFORMATION.....	18

Customer Companies	R&D Dept.	Q.C. Dept.	Eng. Dept.	Prod. Dept.
	JACK	ERIC	PAUL	HELEN
Approved by	Version:	Issued Date:	Sheet Code:	Total Pages:
	1	2009/11/17		18

3. APPLICATION

DVD player, Car TV, UMPC, POS

4. GENERAL SPECIFICATIONS

Parameter	Specifications	Unit
Screen Size	7 (diagonal)	inch
Display Format	800(H) x (R,G,B) x 480(V)	dot
Active Area	152.4(H) x 91.44(V)	mm
Dot Pitch	0.0635 (H) x 0.1905 (V)	mm
Pixel Configuration	Stripe	
Outline Dimension	165(W) x 106.4(H) x 3.4 (D)	mm
Surface treatment	Anti-glare	
Back-light	LED	
Display mode	Normally white	
Weight	TBD	g
View Angle direction	6 o'clock	

5. ABSOLUTE MAXIMUM RATINGS

GND=0V

Parameter	Symbol	MIN.	MAX.	Unit	Remark
Power supply voltage	VCC	-0.3	6	V	Ta=25°C
	AVDD	6.5	13.5	V	
	VGH	7	VGL+40	V	
	VGL	-20	5	V	
	VGH-VGL	12	40	V	
Input Signal voltage	VI	-0.3	V _{CC} +0.3	V	Note 1
	V1-V5	0.4AVDD	AVDD-0.1	V	
	V6-V10	0.1	0.6AVDD	V	
	VCOM	--	--	V	
Operating temperature	Top	-20	70	°C	Module surface*
Storage temperature	Tst	-30	80	°C	-
Humidity	Operation	20%~90% relative humidity			Ta<=38°C
	Non Operation	5%~90% relative humidity			Ta<=38°C

Note 1: DCLK, DE, R0~ R5, G0~ G5, B0~ B5.

6. ELECTRICAL CHARACTERISTICS

6.1 Operating Conditions

GND=0V, fH=31.49KHz, fV=60Hz, fCLK=33.26MHz, Ta=25°C

Parameter	Symbol	MIN.	Typ.	MAX.	Unit	Remark
Power Supply voltage	V _{CC}	3.0	3.3	3.6	V	
	AVDD	11.5	12	12.5	V	
	VGH	17	18	19	V	
	VGL	-8	-7	-6	V	
Input Signal voltage	V1-V5	0.4AVDD	--	AVDD-0.1	V	
	V6-V10	0.1	--	0.6AVDD	V	
	VCOM	--	4.3	--	V	
Power Supply Current	I _{CC}	--	150	200	mA	V _{CC} =3.3V
"H" level logical input voltage	V _{IH}	0.7V _{CC}	--	V _{CC}	V	
"L" level logical input voltage	V _{IL}	0	--	0.3V _{CC}	V	

6.2 Gamma Voltage

Parameter	Value	Unit	Parameter	Value	Unit
V1	10.87	V	V6	4.79	V
V5	6.84	V	V10	0.49	V

6.3 Backlight Driving Consumption

Ta= 25 °C

Parameter	Symbol	Min.	Typ.	Max.	Unit	Remark
LED voltage	V _L	8.4	9.9	10.8	V	Note1
LED current	I _L	-	180	-	mA	
LED dice life time			30000		hr	Note2

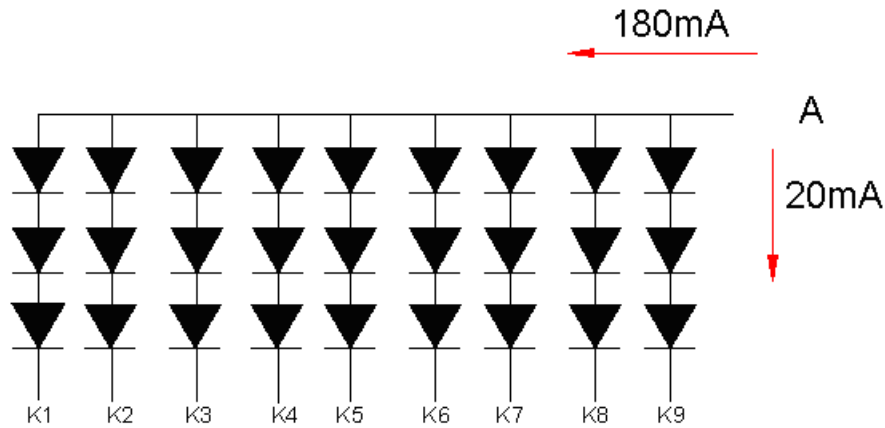

Note1: There are 9 Groups (1 Group of three LEDs).

VLED 1,2,3,4,5,6,7,8,9,=8.4V(min)

Note2: The "LED dice life time" is defined as the brightness decrease to 50% original brightness that the ambient temperature is 18 ~28 and LED dice current=20mA.

7. INPUT SIGNAL CHARACTERISTICS

7.1 AC Characteristics

7.1.1 AC Electrical Characteristics

ITEM	SYMBOL	MIN.	TYP.	MAX.	UNIT
Data setup time	T_{dsu}	6	-	-	ns
Data hold time	T_{dhd}	6	-	-	ns
DE setup time	T_{esu}	6	-	-	ns
DCLK frequency	F_{CPH}	-	33.26	-	MHZ
DCLK period	T_{CPH}	-	30.06	-	ns
DCLK pulse duty	T_{CWH}	40	50	60	%
DE period	$T_{DEH}+T_{DEL}$	1000	1056	1200	T_{CPH}
DE pulse width	T_{DH}	-	800	-	T_{CPH}
DE frame blanking	T_{HS}	10	45	110	$T_{DEH}+T_{DEL}$
DE frame width	T_{EP}	-	480	-	$T_{DEH}+T_{DEL}$

7.2 Timing Controller Timing Chart

7.2.1 Clock and Data input waveforms

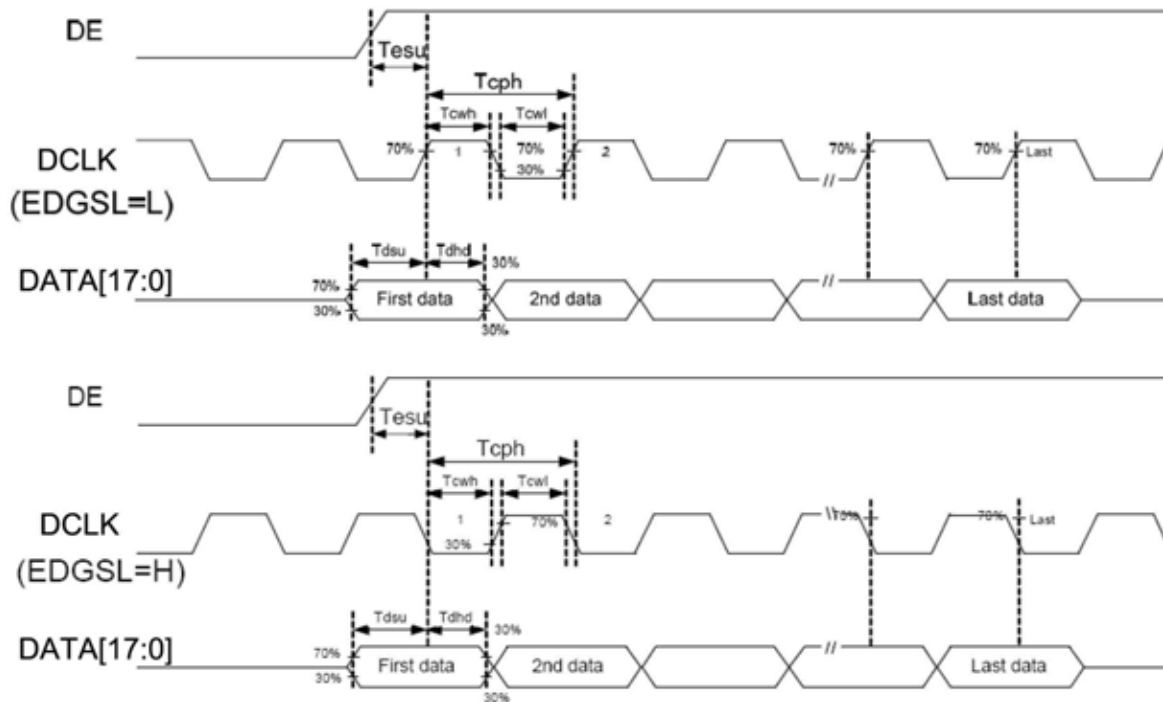

7.2.2 Data Input format

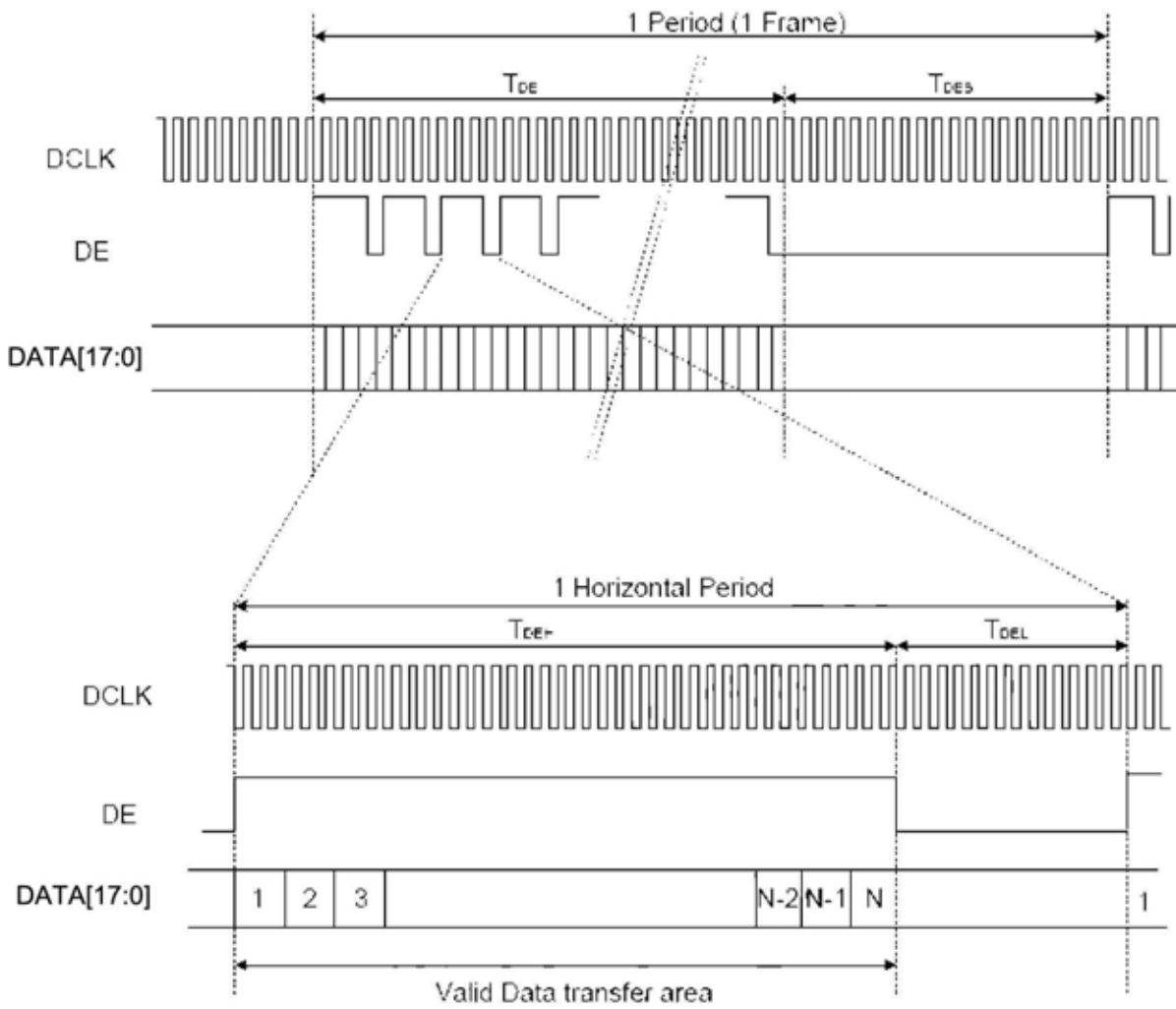

8. OPTICAL CHARACTERISTIC

Parameter		Symbol	Condition	MIN.	TYP.	MAX.	Unit	Remarks
Viewing Angle	Horizontal	θ_{x+}	Center CR \geq 10	65	70	--	deg	Note 1,4
		θ_{x-}		65	70	--		
	Vertical	θ_{y+}		55	60	--		
		θ_{y-}		55	60	--		
Contrast Ratio		CR	at optimized viewing angle	250	400	--		Note 1,3
Response time	Rise	Tr	Center	-	5	10	ms	Note 1,6
	Fall	Tf	$\theta_x=\theta_y=0^\circ$	-	11	16	ms	
Uniformity		B-uni	$\theta_x=\theta_y=0^\circ$	70	80	--	%	Note1,5
Brightness		L	$\theta_x=\theta_y=0^\circ$	--	350	--	cd/m ²	Note 1,2
Chromaticity		x_W	Center $\theta_x=\theta_y=0^\circ$	0.26	0.31	0.36		Note 1,7
		y_W		0.28	0.33	0.38		
		x_R		TBD	TBD	TBD		
		y_R		TBD	TBD	TBD		
		x_G		TBD	TBD	TBD		
		y_G		TBD	TBD	TBD		
		x_B		TBD	TBD	TBD		
		y_B		TBD	TBD	TBD		
Image sticking		tis	2 hours			2	Sec	Note 8

The following optical specifications shall be measured in a darkroom or equivalent state (ambient luminance \leq 1 lux, and at room temperature). The operation temperature is 25°C \pm 2°C and LED Backlight Current IL=180mA. The measurement method is shown in Note1.

Note1: The method of optical measurement:

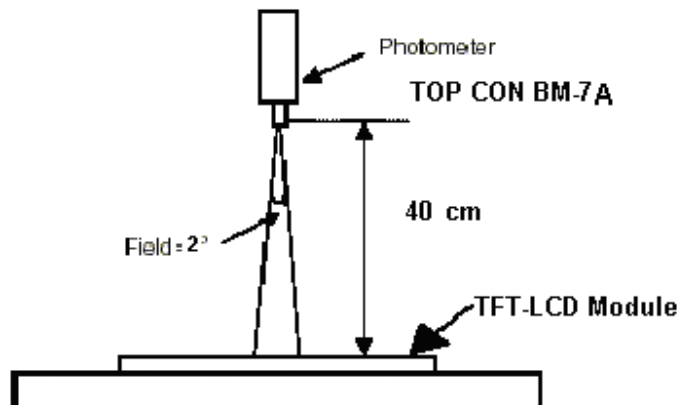

Note2: Measured at the center area of the panel and at the viewing angle of the $\theta_x = \theta_y = 0^\circ$

Note3: Definition of Contrast Ratio (CR):

$$CR = \frac{\text{Luminance with all pixels in white state}}{\text{Luminance with all pixels in Black state}}$$

Note4: Definition of Viewing Angle

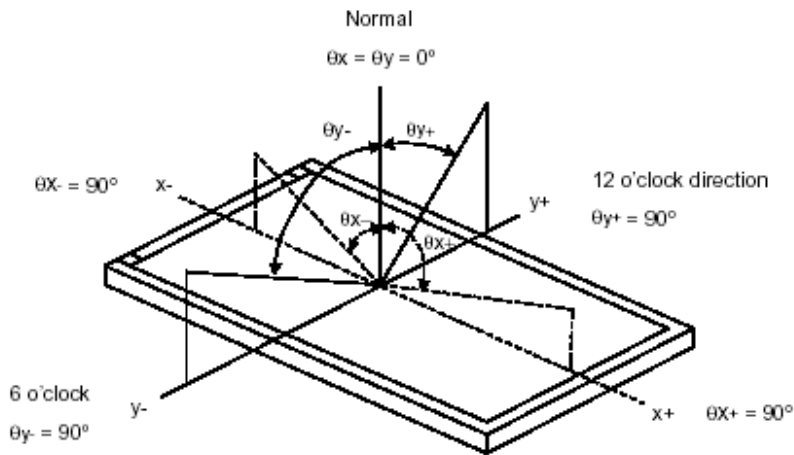

Note 5: Definition of Brightness Uniformity (B-uni):

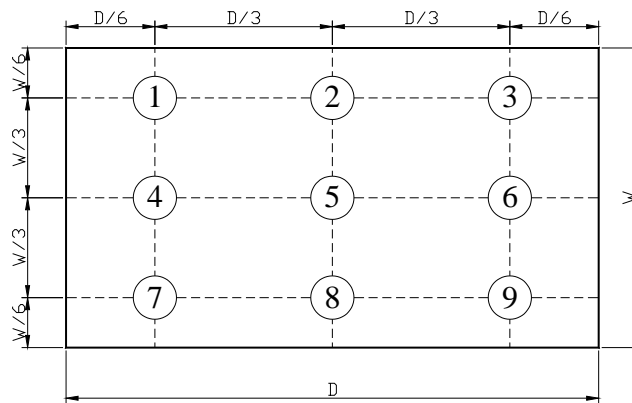

$$B\text{-uni} = \frac{\text{Minimum luminance of 9 points}}{\text{Maximum luminance of 9 points}} \quad (\text{Note 5}).$$

Note6: Definition of Response Time:

The Response Time is set initially by defining the “Rising Time (Tr)” and the “Falling Time (Tf)” respectively. Tr and Tf are defined as following figure.

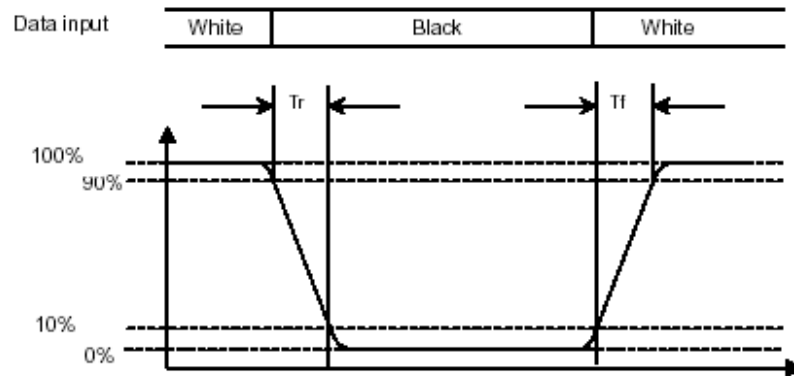

Note 7: Definition of Chromaticity:

The color coordinates (x_W, y_W) , (x_R, y_R) , (x_G, y_G) , and (x_B, y_B) are obtained with all pixels in the viewing field at white, red, green, and blue states, respectively.

Note 8: Definition of Image sticking (tis):

Continuously display the test pattern shown in the figure below for 2 hours. Then display a completely white screen. The previous image shall not persist more than 2 sec at 25 °C

Image sticking pattern

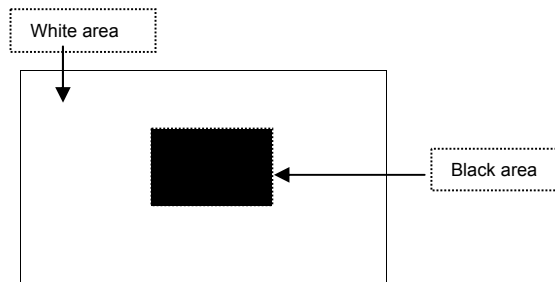

9. PIN CONNECTIONS

Pin No.	Symbol	Description	Remark
1	NC	No Connection	
2	NC	No Connection	
3	NC	No Connection	
4	NC	No Connection	
5	NC	No Connection	
6	GND	Power Ground	
7	EDGSL	Define Input Clock Polarity. When EDGSL=L, Latch Data By Rising Edge of CLK. (Default Pull Low) When EDGSL=H, CLK Polarity is Inverted, Latch Data by Falling Edge of CLK.	
8	VCC	Digital Power Supply (+3.3V)	
9	V9	Gamma voltage level 9	
10	VGL	Gate OFF power supply voltage	
11	V2	Gamma voltage level 2	
12	VGH	Gate ON power supply voltage	
13	V6	Gamma voltage level 6	
14	RESETB	Hardware Global Reset. Low Active. (Default Pull high)	
15	VCOM	Common electrode voltage input	
16	GND	Power Ground	
17	AVDD	Analog Power Supply (+12V)	
18	NC	No Connection	
19	NC	No Connection	
20	V8	Gamma voltage level 8	
21	V5	Gamma voltage level 5	
22	V3	Gamma voltage level 3	
23	GND	Power ground	
24	R5	Red data (MSB)	
25	R4	Red data	
26	R3	Red data	
27	R2	Red data	
28	R1	Red data	
29	R0	Red data (LSB)	
30	GND	Power ground	
31	GND	Power ground	
32	G5	Green data (MSB)	
33	G4	Green data	
34	G3	Green data	
35	G2	Green data	
36	G1	Green data	

37	G0	Green data (LSB)	
38	DE	Input Data Enable Control. When DE Mode. Active High To Enable Data Input. (Default Pull Low)	
39	NC	NC	
40	GND	Power ground	
41	DCLK	Clock Signal Input. When CLK=H, User Can Input Different Polarity CLK By EDGSL Setting. When CLK=L, User Can Select CLK Rising Or Dual Edge To Latch By EDGSL Setting.	
42	VCC	Digital Power Supply (+3.3V)	
43	NC	No Connection	
44	NC	No Connection	
45	B5	Blue data (MSB)	
46	B4	Blue data	
47	B3	Blue data	
48	B2	Blue data	
49	B1	Blue data	
50	B0	Blue data (LSB)	
51	NC	No Connection	
52	V1	Gamma voltage level 1	
53	V4	Gamma voltage level 4	
54	V7	Gamma voltage level 7	
55	V10	Gamma voltage level 10	
56	NC	No Connection	
57	NC	No Connection	
58	AVDD	Analog Power Supply (12V)	
59	GND	Power ground	
60	VCOM	Common electrode voltage input	

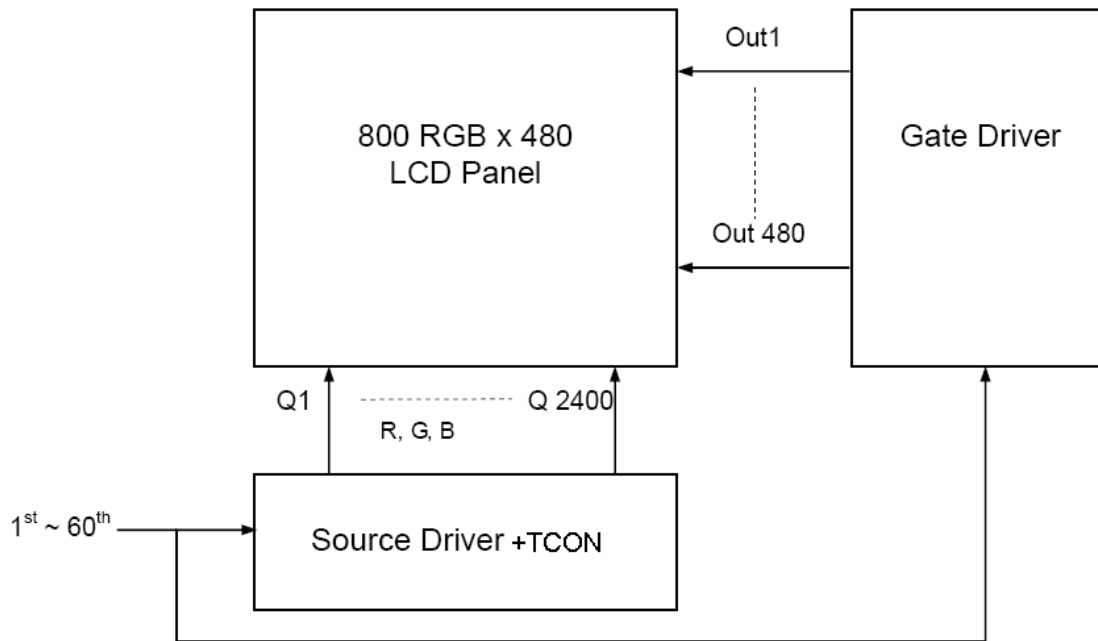
10. BLOCK DIAGRAM

11. APPLICATION CIRCUIT

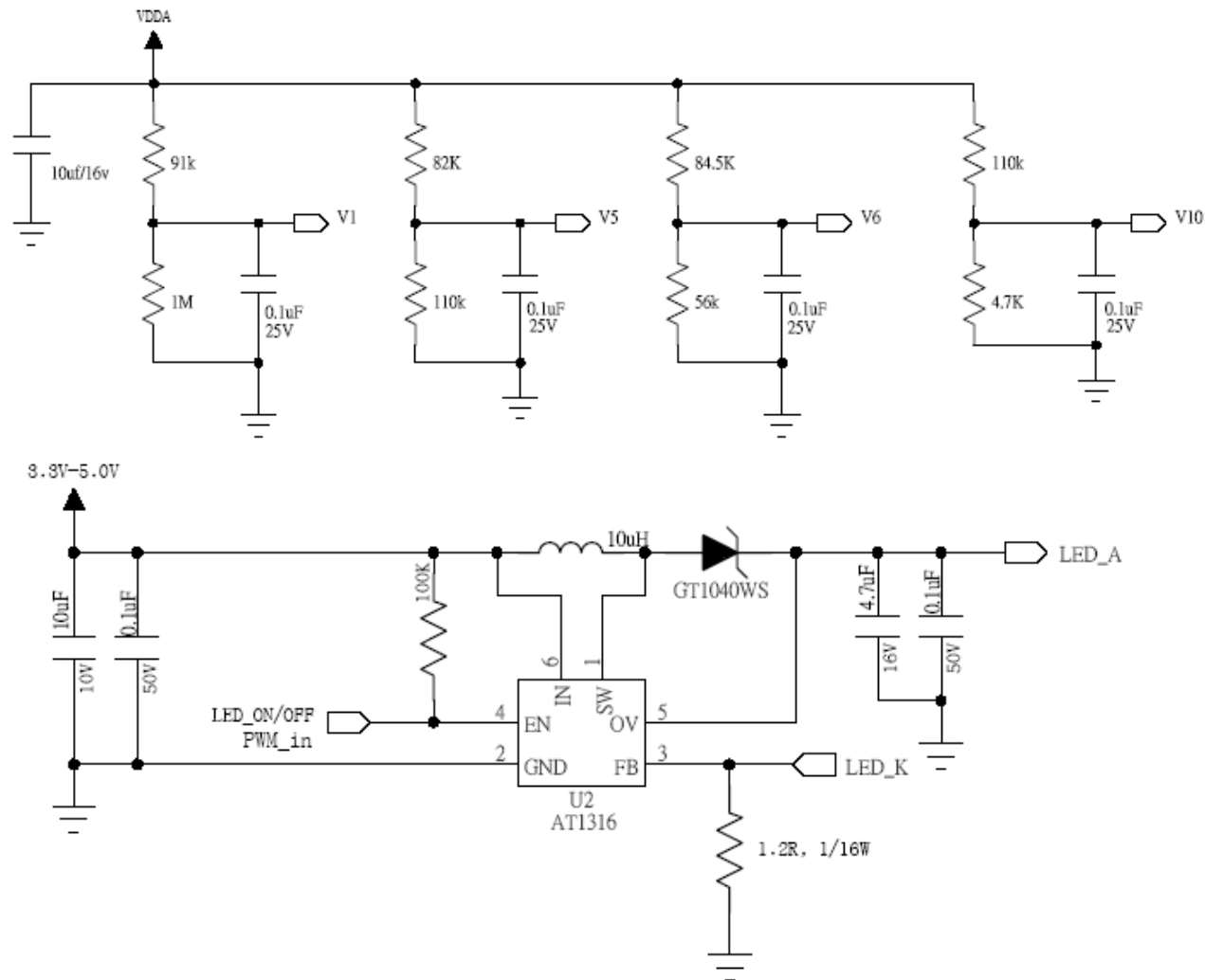

Gamma & B/L circuit

12. QUALITY ASSURANCE

12.1 Test Condition

12.1.1 Temperature and Humidity(Ambient Temperature)

Temperature : $25 \pm 5^{\circ}\text{C}$

Humidity : $65 \pm 5\%$

12.1.2 Operation

Unless specified otherwise, test will be conducted under function state.

12.1.3 Container

Unless specified otherwise, vibration test will be conducted to the product itself without putting it in a container.

12.1.4 Test Frequency

In case of related to deterioration such as shock test. It will be conducted only once.

12.1.5 Test Method

Reliability Test Item & Level		Test Level
No.	Test Item	
1	High Temperature Storage Test	T=80 ,240hrs
2	Low Temperature Storage Test	T=-30 ,240hrs
3	High Temperature Operation Test	T=70 ,240hrs
4	Low Temperature Operation Test	T=-20 ,240hrs
5	High Temperature and High Humidity (No operation)	T=60 ,90%RH,240hrs
6	Thermal Cycling Test (No operation)	-30 → +25 → +80 , 100 Cycles 30 min 5 min 30 min
7	Vibration Test (No operation)	Frequency :10 ~ 55 Hz Amplitude :1.5 mm Sweep time : 11 mins Test Period: 6 Cycles for each direction of X, Y, Z

12.2 Judgment standard

The Judgment of the above test should be made as follow:

Pass: Normal display image with no obvious non-uniformity and no line defect. Partial transformation of the module parts should be ignored.

Fail: No display image, obvious non-uniformity, or line defect.

13. LOT NUMBERING SYSTEM

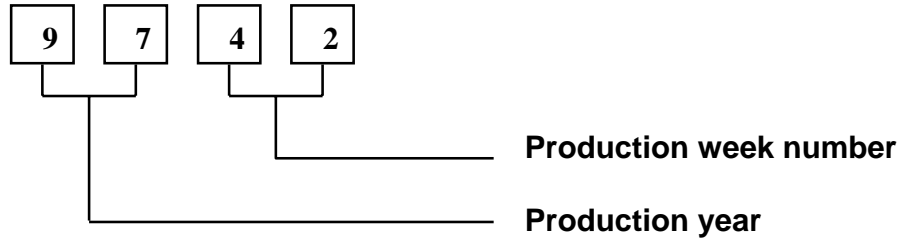

14. LCM NUMBERING SYSTEM

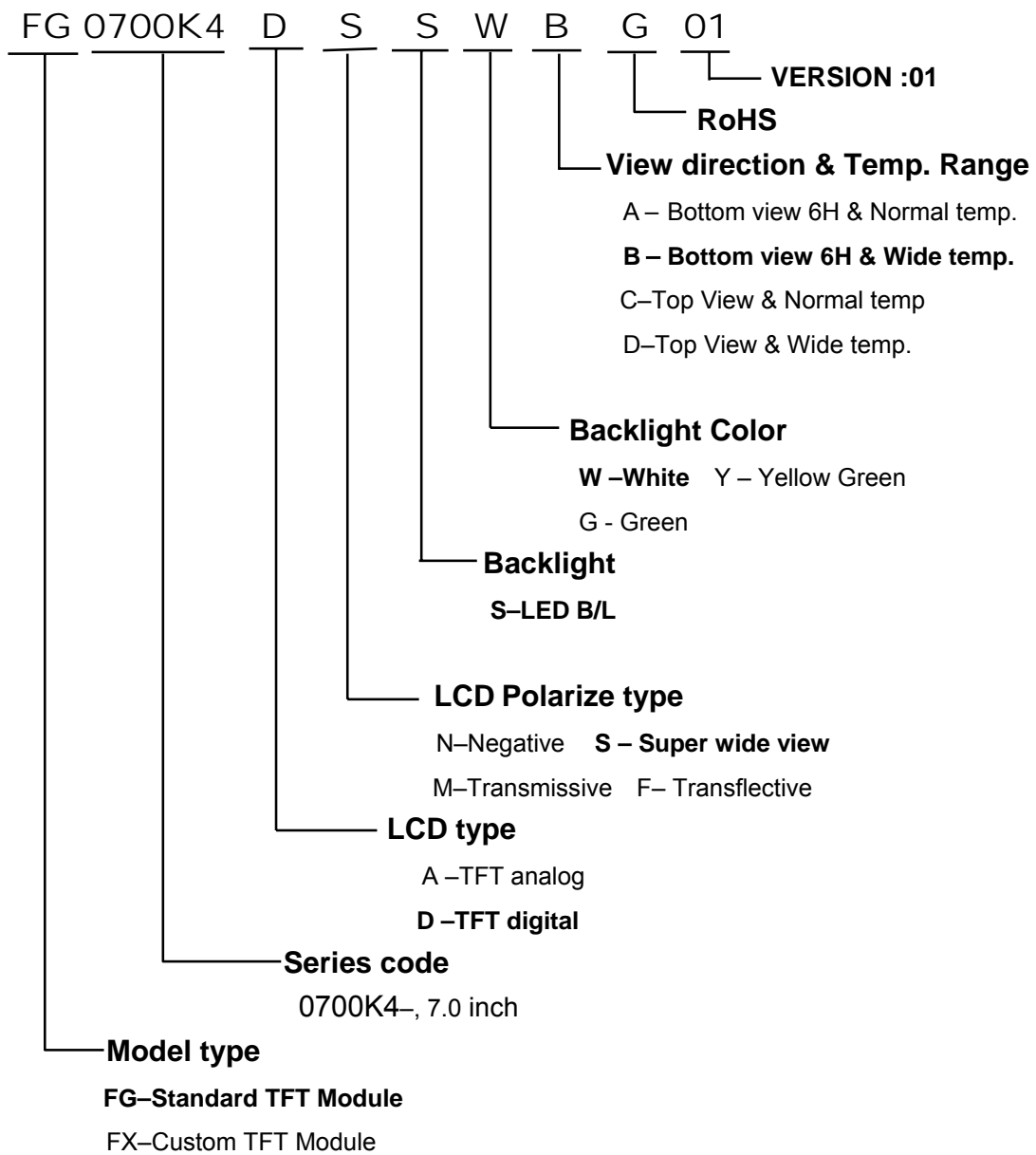

15. PRECAUTIONS IN USE LCM

1. LIQUID CRYSTAL DISPLAY (LCD)

LCD is made up of glass, organic sealant, organic fluid, and polymer based polarizers. The following precautions should be taken when handling,

- (1). Keep the temperature within range of use and storage. Excessive temperature and humidity could cause polarization degradation, polarizer peel off or bubble.
- (2). Do not contact the exposed polarizers with anything harder than an HB pencil lead. To clean dust off the display surface, wipe gently with cotton, chamois or other soft material soaked in petroleum benzine.
- (3). Wipe off saliva or water drops immediately. Contact with water over a long period of time may cause polarizer deformation or color fading, while an active LCD with water condensation on its surface will cause corrosion of ITO electrodes.
- (4). Glass can be easily chipped or cracked from rough handling, especially at corners and edges.
- (5). Do not drive LCD with DC voltage.

2. Liquid Crystal Display Modules

2.1 Mechanical Considerations

LCM are assembled and adjusted with a high degree of precision. Avoid excessive shocks and do not make any alterations or modifications. The following should be noted.

- (1). Do not tamper in any way with the tabs on the metal frame.
- (2). Do not modify the PCB by drilling extra holes, changing its outline, moving its components or modifying its pattern.
- (3). Do not touch the elastomer connector, especially insert an backlight panel (for example, EL).
- (4). When mounting a LCM make sure that the PCB is not under any stress such as bending or twisting. Elastomer contacts are very delicate and missing pixels could result from slight dislocation of any of the elements.
- (5). Avoid pressing on the metal bezel, otherwise the elastomer connector could be deformed and lose contact, resulting in missing pixels.

2.2. Static Electricity

LCM contains CMOS LSI's and the same precaution for such devices should apply, namely

- (1). The operator should be grounded whenever he/she comes into contact with the module. Never touch any of the conductive parts such as the LSI pads, the copper leads on the PCB and the interface terminals with any parts of the human body.
- (2). The modules should be kept in antistatic bags or other containers resistant to static for storage.
- (3). Only properly grounded soldering irons should be used.
- (4). If an electric screwdriver is used, it should be well grounded and shielded from commutator sparks.

- (5) The normal static prevention measures should be observed for work clothes and working benches; for the latter conductive (rubber) mat is recommended.
- (6). Since dry air is inductive to statics, a relative humidity of 50-60% is recommended.

2.3 Soldering

- (1). Solder only to the I/O terminals.
- (2). Use only soldering irons with proper grounding and no leakage.
- (3). Soldering temperature : $280^{\circ}\text{C} \pm 10^{\circ}\text{C}$
- (4). Soldering time: 3 to 4 sec.
- (5). Use eutectic solder with resin flux fill.
- (6). If flux is used, the LCD surface should be covered to avoid flux spatters. Flux residue should be removed afterwards.

2.4 Operation

- (1). The viewing angle can be adjusted by varying the LCD driving voltage V_0 .
- (2). Driving voltage should be kept within specified range; excess voltage shortens display life.
- (3). Response time increases with decrease in temperature.
- (4). Display may turn black or dark blue at temperatures above its operational range; this is (however not pressing on the viewing area) may cause the segments to appear "fractured".
- (5). Mechanical disturbance during operation (such as pressing on the viewing area) may cause the segments to appear "fractured".

2.5 Storage

If any fluid leaks out of a damaged glass cell, wash off any human part that comes into contact with soap and water. Never swallow the fluid. The toxicity is extremely low but caution should be exercised at all the time.

2.6 Limited Warranty

Unless otherwise agreed between DATA IMAGE and customer, DATA IMAGE will replace or repair any of its LCD and LCM which is found to be defective electrically and visually when inspected in accordance with DATA IMAGE acceptance standards, for a period on one year from date of shipment. Confirmation of such date shall be based on freight documents. The warranty liability of DATA IMAGE is limited to repair and/or replacement on the terms set forth above. DATA IMAGE will not responsible for any subsequent or consequential events.

Confidential Document
16. OUTLINE DRAWING

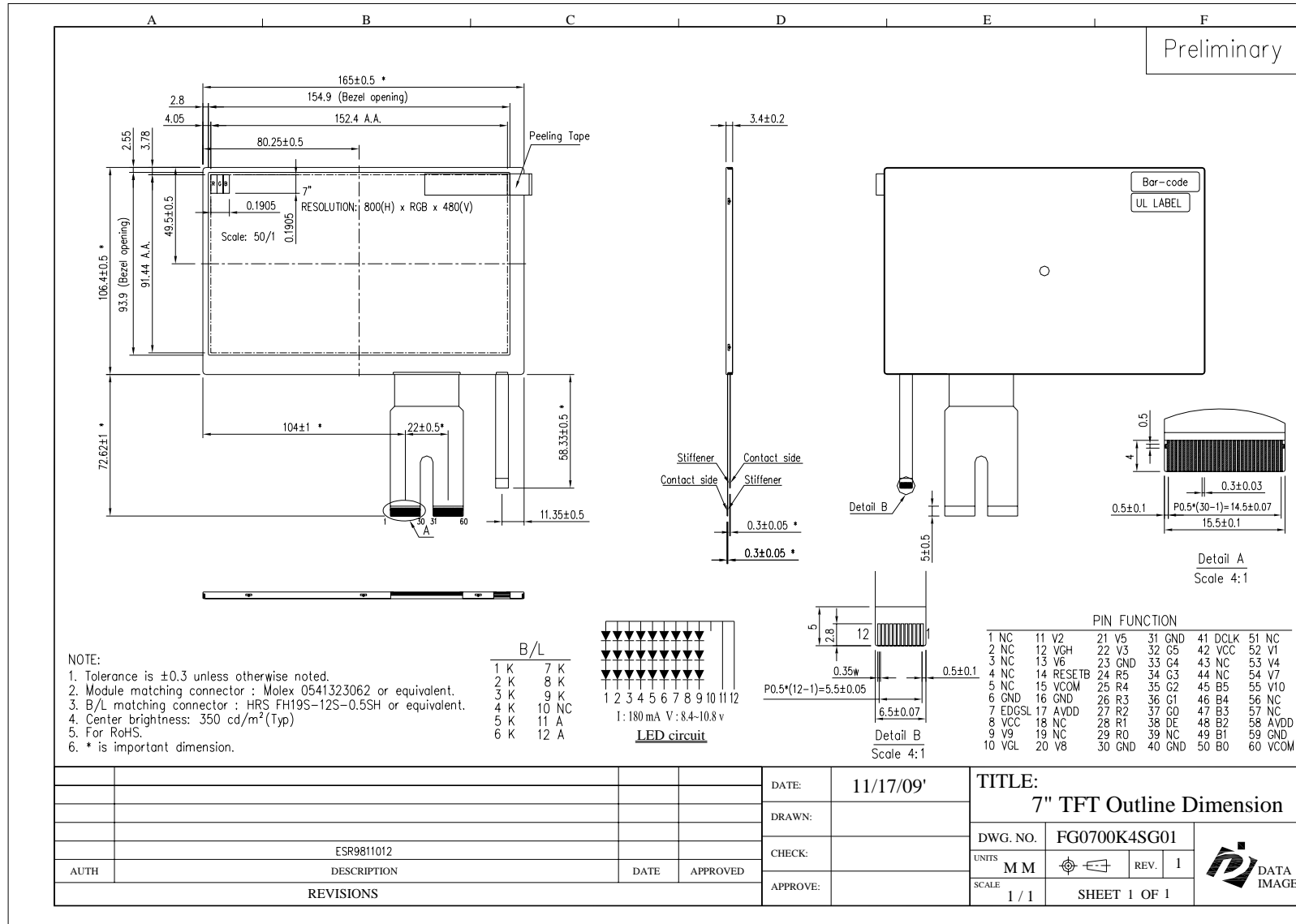

17. PACKAGE INFORMATION

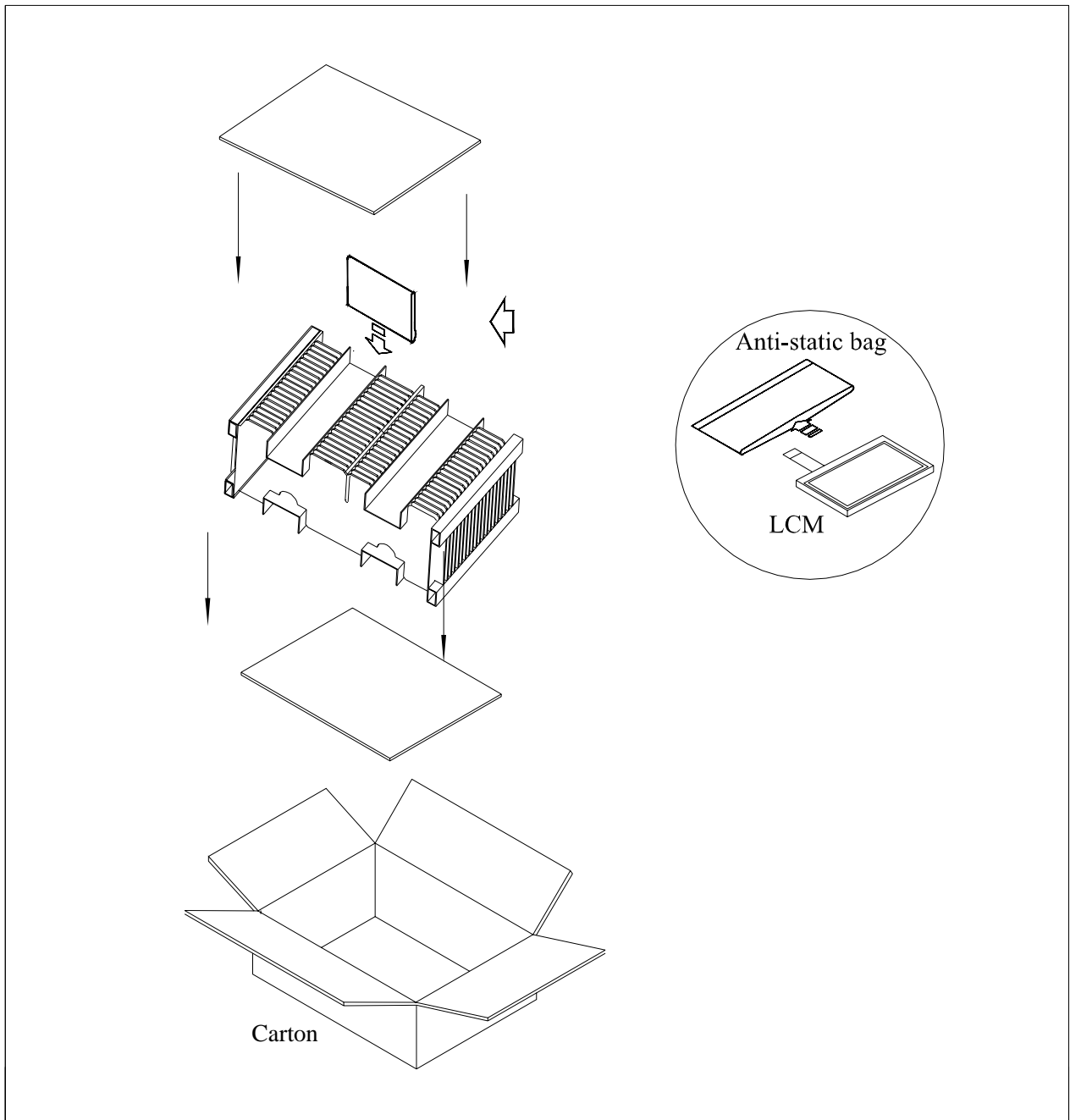

Item	Size(L*W*H)	Quantity	Note
Master Carton	482*282*279	1	
Quantity Per Master Carton		38	
N . W	T.B.D (kg)	G . W	T.B.D (kg)