



DATA IMAGE CORPORATION

TFT Module Specification

ITEM NO.: FG050720DSSWDGL4

Table of Contents

1. COVER & CONTENTS	1
2. RECORD OF REVISION	2
3. APPLICATION.....	3
4. GENERAL SPECIFICATIONS	3
5. ABSOLUTE MAXIMUM RATINGS	3
6. ELECTRICAL CHARACTERISTICS	3
7. BLOCK DIAGRAM	4
8. PIN CONNECTIONS	5
9. INTERFACE SPECIFICATIONS	7
10. OPTICAL CHARACTERISTIC	12
11. QUALITY ASSURANCE	15
12. LCM PRODUCT LABEL DEFINE	19
13. PRECAUTIONS IN USE LCM	21
14. OUTLINE DRAWING	22
15. PACKAGE INFORMATION	23

Customer Companies	R&D Dept.	Q.C. Dept.	Eng. Dept.	Prod. Dept.
	JACK	JOE	GARY	KEN
Approved by	Version:	Issued Date:	Sheet Code:	Total Pages:
	A	1/JUL/13'		23

2. RECORD OF REVISION

Rev	Date	Item	Page	Comment
1	20/DEC/11'			Initial preliminary
2	9/MAR/12'	6	3	Modify ILED and LED Dice life time
A	1/JUL13'	10 11.1.5 11.2 14	12 15 16 22	1. Add Chromaticity data. 2. Add Remark. 3. Add Inspection condition. 4. Modify Outline Drawing from Rev.1 to A. 5. Release Rev: A for production.

3. APPLICATION

Digital equipments which need color display, such as P.O.S, medical equipments and industrial equipments.

4. GENERAL SPECIFICATIONS

Parameter	Specifications	Unit
Display resolution	640X (R.G.B) (W) x480(H)	dot
Active area	115.2(W) x 86.4(H)	mm
Screen size	5.7(Diagonal)	inch
Dot pitch	0.06(W) x 0.18(H)	mm
Color configuration	R.G.B. Stripe	
Overall dimension	127 (W) x 98.43(H) x 7Max.(T)	mm
Weight	110	g
Surface treatment	Clear	
View Angle direction	12 o'clock	
Our components and processes are compliant to RoHS standard		

5. ABSOLUTE MAXIMUM RATINGS

Parameter	Symbol	MIN.	MAX.	Unit	Remark
Power supply voltage	V _{CC}	-0.3	5.0	V	
Logic input voltage	V _I	-0.3	V _{CC} +0.3	V	
Operating temperature	T _{OP}	-20	+70	°C	Ambient temperature
Storage temperature	T _{ST}	-30	+80	°C	Ambient temperature

6. ELECTRICAL CHARACTERISTICS

V_{SS}=0V, DCLK=25MHz, T_a=25°C

Parameter	Symbol	MIN.	Typ.	MAX.	Unit	Remark
Power Supply voltage for LCD	V _{CC}	+3.0	+3.3	+3.6	V	
Power Supply Current for LCD	I _{CC}	--	111	140	mA	V _{CC} =3.3V
Power Supply voltage for LED	V _{LED}	4.5	5	5.5	V	
Power Supply Current for LED	I _{LED}		333	400	mA	V _{LED} =5.0V
Ripple voltage	V _{RF}	--	--	100	mV _{P-P}	
"H" level logical input voltage	V _{IH}	0.7V _{CC}	--	V _{CC}	V	
"L" level logical input voltage	V _{IL}	0	--	0.3V _{CC}	V	
ADJ frequency		19K	20K	21K	Hz	
ADJ input voltage	V _{IH}	3.0	--	3.3	V	
	V _{IL}	0	--	0.3	V	
LED Dice life time		--	50000	--	Hr	Note 1

Note 1: The "LED dice life time" is defined as the brightness decrease to 50% original brightness that the ambient temperature is 22°C and LED dice current=20mA.

7. BLOCK DIAGRAM

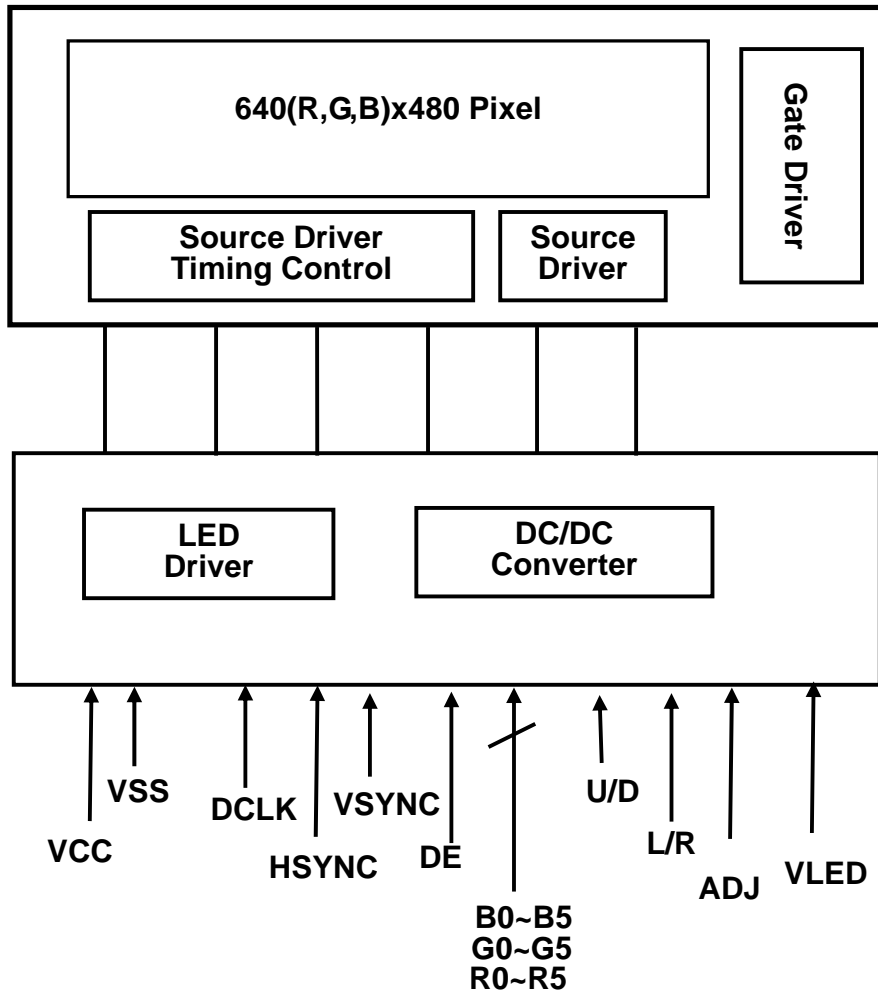

8. PIN CONNECTIONS

Pin NO.	SYMBOL	DESCRIPTION
1	U/D	Up or Down Display Control
2	NC	No Connection
3	Hsync	Horizontal SYNC.
4	VLED	Power Supply for LED Driver circuit
5	VLED	Power Supply for LED Driver circuit
6	VLED	Power Supply for LED Driver circuit
7	V _{cc}	Power Supply for LCD
8	Vsync	Vertical SYNC.
9	DE	Data Enable
10	VSS	Power Ground
11	VSS	Power Ground
12	ADJ	Brightness control for LED B/L
13	B5	Blue Data 5 (MSB)
14	B4	Blue Data 4
15	B3	Blue Data 3
16	V _{ss}	Power Ground
17	B2	Blue Data 2
18	B1	Blue Data 1
19	B0	Blue Data 0 (LSB)
20	V _{ss}	Power Ground
21	G5	Green Data 5 (MSB)
22	G4	Green Data 4
23	G3	Green Data 3
24	V _{ss}	Power Ground
25	G2	Green Data 2
26	G1	Green Data 1
27	G0	Green Data 0 (LSB)
28	V _{ss}	Power Ground
29	R5	Red Data 5 (MSB)
30	R4	Red Data 4
31	R3	Red Data 3
32	V _{ss}	Power Ground
33	R2	Red Data 2
34	R1	Red Data 1
35	R0	Red Data 0
36	VSS	Power Ground
37	VSS	Power Ground
38	DCLK	Clock Signals ; Latch Data at the Falling Edge
39	V _{ss}	Power Ground
40	L/R	Left or Right Display Control

Remarks :

- 1) ADJ is brightness control Pin. The larger of the pulse duty is, the higher of the brightness.
- 2) ADJ signal is 0~3.3V. Operation frequency is 20KHz
- 3) VSS PIN must be grounding, can not be floating.

4) U/D and L/R control Function

L/R	U/D	Function
1	0	Normally display
0	0	Left and Right opposite
1	1	Up and Down opposite
0	1	Left and Right opposite , Up and Down opposite

5) If DE signal is fixed low, SYNC mode is used. Otherwise, DE mode is used.

8.1 Power Signal Sequence

Remarks:

*1) Power Signal sequence:

$t1 \leq 10\text{ms}$: $1 \text{ sec} \leq t5$

$50\text{ms} \leq t2$: $200\text{ms} \leq t6$

$0 < t3 \leq 50\text{ms}$: $200\text{ms} \leq t7$

$0 < t4 \leq 10\text{ms}$

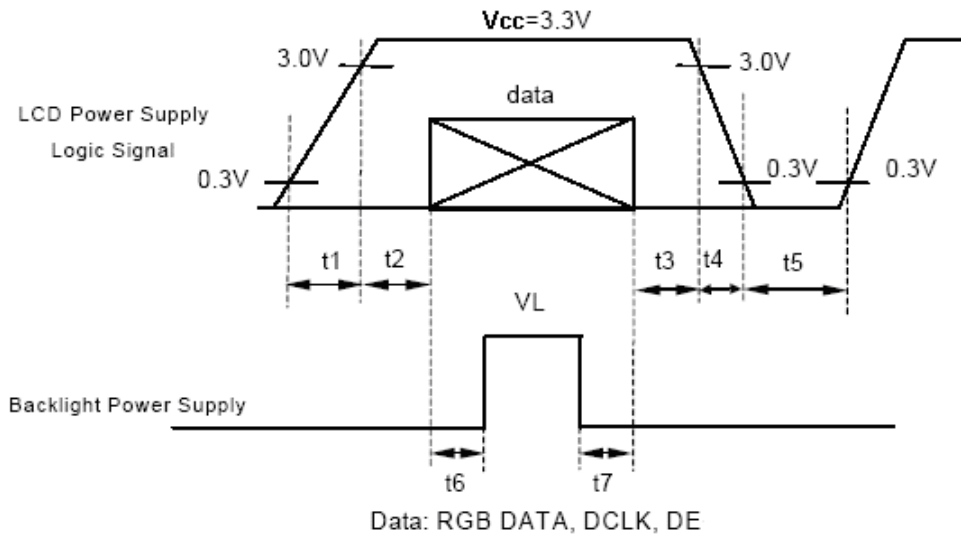

*2) VCC-dip condition:

(1) $2.7 \text{ V} \leq VCC < 3.0\text{V}$, $t_d \leq 10 \text{ ms}$

(2) $VCC > 3.0\text{V}$, VCC-dip condition should be the same with VCC-turn-on condition.

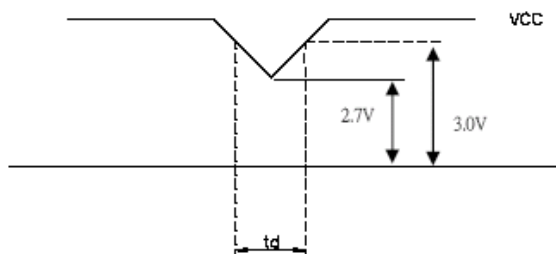

9. INTERFACE SPECIFICATIONS

9.1 DE mode Input signal characteristics

Signal	Parameter	Symbol	MIN.	TYP.	MAX.	Unit	Remarks
DCLK	Period	t_{CLK}	33	40	43	ns	
	Frequency	f_{CLK}	23	25	30	MHz	
	Low Level Width	t_{WCL}	6	-	-	ns	
	High Level Width	t_{WCH}	6	-	-	ns	
	Rise, Fall Time	t_{CLKr}, t_{CLKf}	-	-	3	ns	
	Duty	-	0.45	0.50	0.55	-	
DE (Data Enable)	Setup Time	t_{DES}	5	-	-	ns	
	Hold Time	t_{DEH}	10	-	-	ns	
	Rise, Fall Time	t_{DEr}, t_{DEf}	-	-	16	ns	
	Horizontal Period	t_{HP}	750	800	900	t_{CLK}	
	Horizontal Valid	t_{HV}	640	640	640	t_{CLK}	
	Horizontal Blank	t_{HBK}	110	160	260	t_{CLK}	
	Vertical Period	t_{VP}	515	525	560	t_{HP}	
	Vertical Valid	t_{V}	480	480	480	t_{HP}	
	Vertical Blank	t_{VBK}	35	45	80	t_{HP}	
	Vertical Frequency	f_v	55	60	65	Hz	
Data R,G,B	Setup Time	t_{DS}	5	-	-	ns	
	Hold Time	t_{DH}	10	-	-	ns	
	Rise, Fall Time	t_{Dr}, t_{Df}	-	-	3	ns	

Note: (1) t_{CLKL} / t_{CLK} .

9.1.1 DE mode timing waveform

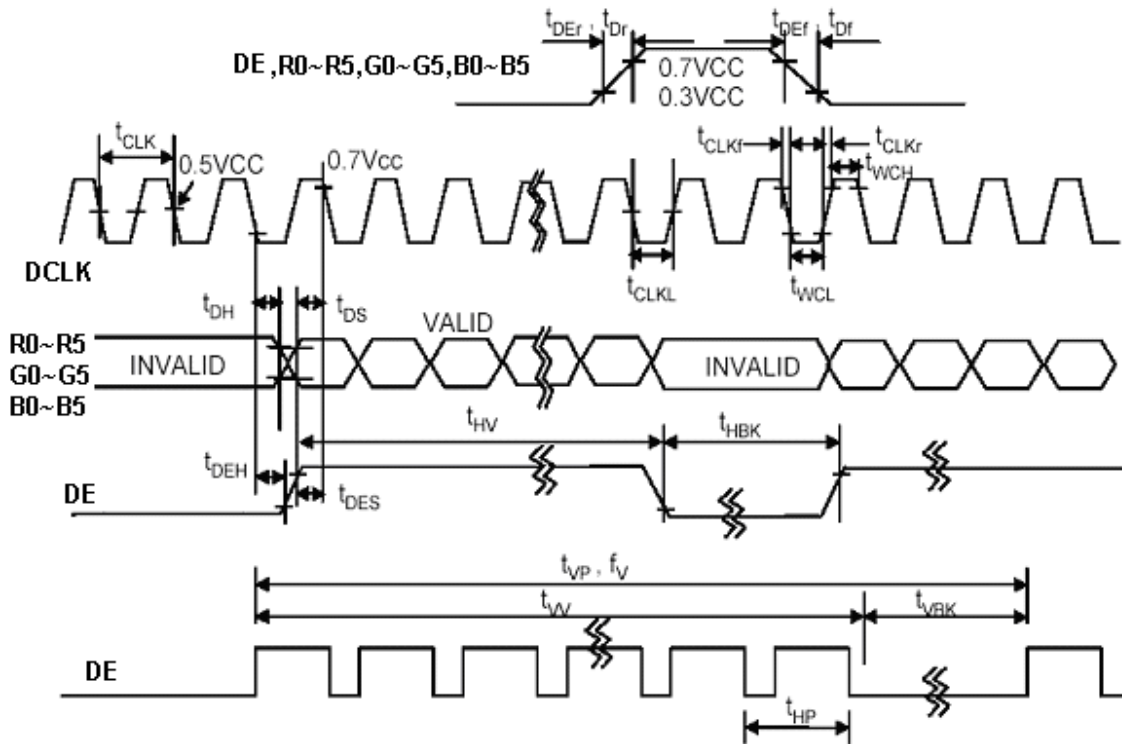

9.2 SYNC mode Input signal characteristics

Parameter	Symbol	MIN.	TYP.	MAX.	Unit	Remarks
Clock Period	t_{CLK}	33	40	43	ns	
Clock Frequency	f_{CLK}	23	25	30	MHz	
Clock Low Level Width	t_{WCL}	6	-	-	ns	
Clock High Level Width	t_{WCH}	6	-	-	ns	
Clock Rise, Fall Time	t_{CLKr}, t_{CLKf}	-	-	3	ns	
HSYNC Period	t_{HP}	750	800	900	t_{CLK}	
HSYNC Pulse Width	t_{HW}	5	30	-	t_{CLK}	
HSYNC Front Porch	t_{HFP}	1	16	116	t_{CLK}	
HSYNC Back Porch	t_{HBP}	1	114	139	t_{CLK}	
HSYNC Width + Back Porch	$t_{HW} + t_{HBP}$	144	144	144	t_{CLK}	
Horizontal Blank	t_{HBK}	1	160	260	t_{CLK}	
Horizontal Valid	t_{HV}	640	640	640	t_{CLK}	
VSYNC Period	t_{VP}	515	525	560	t_{HP}	
VSYNC Pulse Width	t_{VW}	1	3	5	t_{HP}	
VSYNC Front Porch	t_{VFP}	1	10	45	t_{HP}	
VSYNC Back Porch	t_{VBP}	30	32	34	t_{HP}	
VSYNC Width + Back Porch	$t_{VW} + t_{VBP}$	35	35	35	t_{CLK}	
Vertical Blank	t_{VBK}	35	45	80	t_{HP}	
Vaild data Width	t_W	480	480	480	t_{HP}	
Data Setup Time	t_{DS}	5	-	-	ns	
Data Hold Time	t_{DH}	10	-	-	ns	

Note: (1) $t_{HBK} = t_{HFP} + t_{HW} + t_{HBP}$

9.2.1 SYNC mode timing waveform

9.2.1.1 Input vertical timing

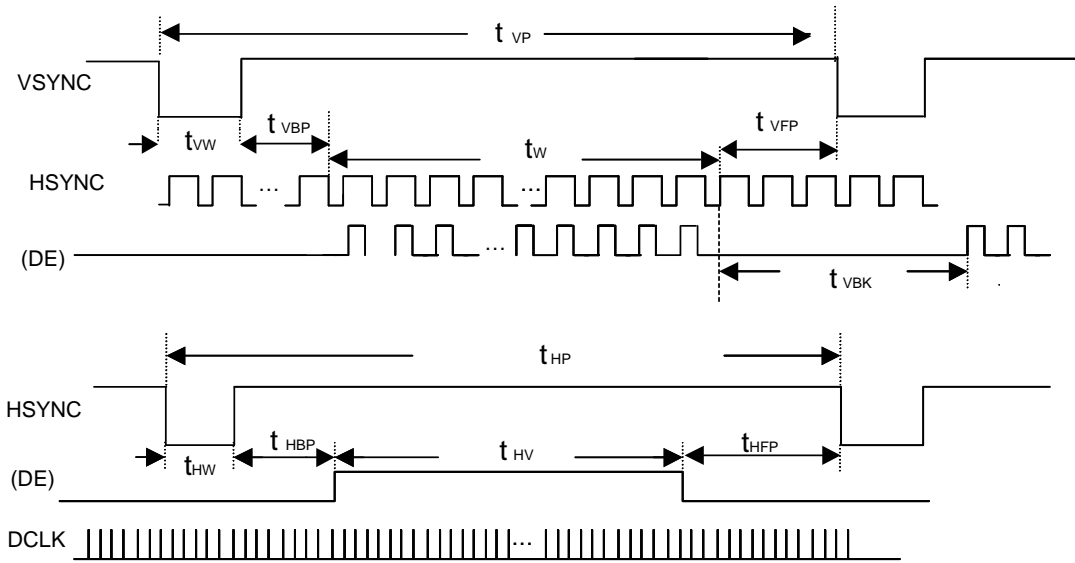

Remark : If SYNC mode is used, please fix DE signal to low, DE timing waveform is for reference only.

9.2.1.2 Input horizontal timing

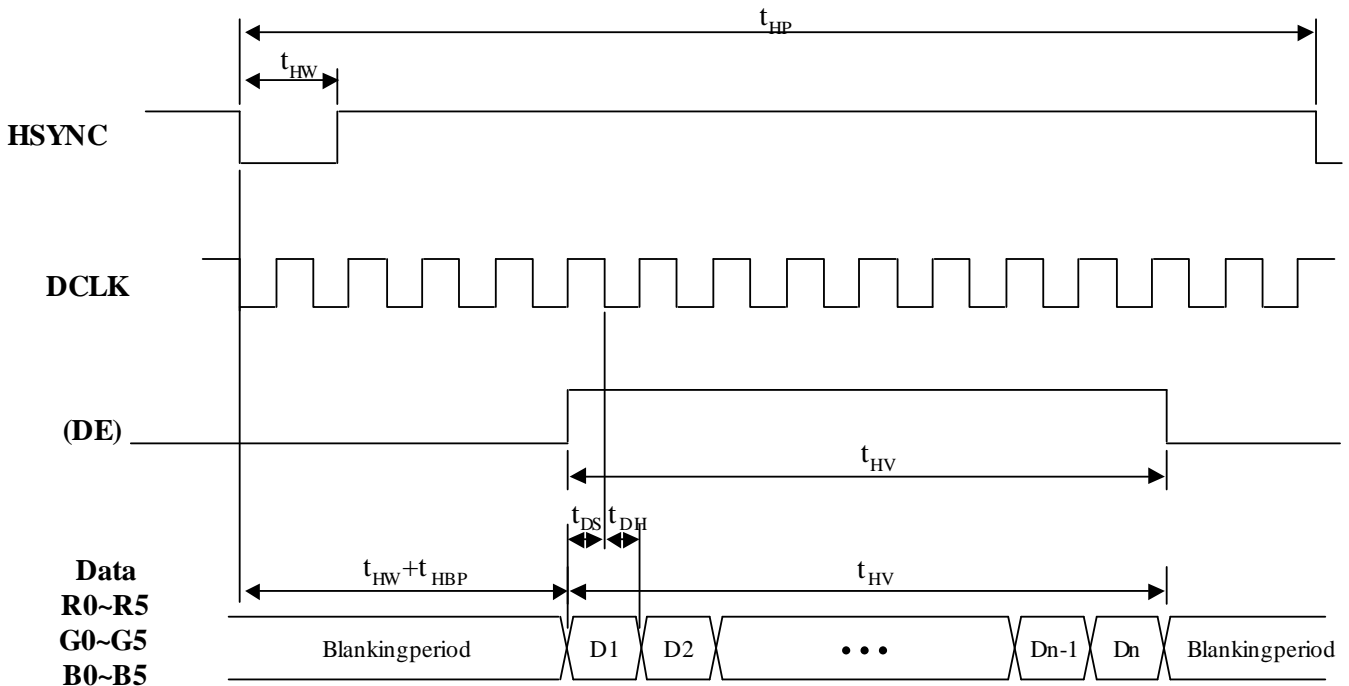

Remark : If SYNC mode is used, please fix DE signal to low, DE timing waveform is for reference only

9.3 Color Data Assignment

COLOR	INPUT	R DATA						G DATA						B DATA					
		DATA	R5	R4	R3	R2	R1	R0	G5	G4	G3	G2	G1	G0	B5	B4	B3	B2	B1
		MSB					LSB	MSB					LSB	MSB					LSB
BASIC COLOR	BLACK	0	0	0	0	0	0	0	0	0	0	0	0	0	0	0	0	0	0
	RED(63)	1	1	1	1	1	1	0	0	0	0	0	0	0	0	0	0	0	0
	GREEN(63)	0	0	0	0	0	0	1	1	1	1	1	1	0	0	0	0	0	0
	BLUE(63)	0	0	0	0	0	0	0	0	0	0	0	0	1	1	1	1	1	1
	CYAN	0	0	0	0	0	0	1	1	1	1	1	1	1	1	1	1	1	1
	MAGENTA	1	1	1	1	1	1	0	0	0	0	0	0	1	1	1	1	1	1
	YELLOW	1	1	1	1	1	1	1	1	1	1	1	1	0	0	0	0	0	0
	WHITE	1	1	1	1	1	1	1	1	1	1	1	1	1	1	1	1	1	1
RED	RED(0)	0	0	0	0	0	0	0	0	0	0	0	0	0	0	0	0	0	0
	RED(1)	0	0	0	0	0	1	0	0	0	0	0	0	0	0	0	0	0	0
	RED(2)	0	0	0	0	1	0	0	0	0	0	0	0	0	0	0	0	0	0
	:	:	:	:	:	:	:	:	:	:	:	:	:	:	:	:	:	:	:
	:	:	:	:	:	:	:	:	:	:	:	:	:	:	:	:	:	:	:
	RED(62)	1	1	1	1	1	0	0	0	0	0	0	0	0	0	0	0	0	0
	RED(63)	1	1	1	1	1	1	0	0	0	0	0	0	0	0	0	0	0	0
GREEN	GREEN(0)	0	0	0	0	0	0	0	0	0	0	0	0	0	0	0	0	0	0
	GREEN(1)	0	0	0	0	0	0	0	0	0	0	0	1	0	0	0	0	0	0
	GREEN(2)	0	0	0	0	0	0	0	0	0	0	1	0	0	0	0	0	0	0
	:	:	:	:	:	:	:	:	:	:	:	:	:	:	:	:	:	:	:
	:	:	:	:	:	:	:	:	:	:	:	:	:	:	:	:	:	:	:
	GREEN(62)	0	0	0	0	0	0	1	1	1	1	1	0	0	0	0	0	0	0
	GREEN(63)	0	0	0	0	0	0	1	1	1	1	1	1	0	0	0	0	0	0
BLUE	BLUE(0)	0	0	0	0	0	0	0	0	0	0	0	0	0	0	0	0	0	0
	BLUE(1)	0	0	0	0	0	0	0	0	0	0	0	0	0	0	0	0	0	1
	BLUE(2)	0	0	0	0	0	0	0	0	0	0	0	0	0	0	0	0	1	0
	:	:	:	:	:	:	:	:	:	:	:	:	:	:	:	:	:	:	:
	:	:	:	:	:	:	:	:	:	:	:	:	:	:	:	:	:	:	:
	BLUE(62)	0	0	0	0	0	0	0	0	0	0	0	0	1	1	1	1	1	0
	BLUE(63)	0	0	0	0	0	0	0	0	0	0	0	0	1	1	1	1	1	1

Remarks:(1) Definition of Gray Scale
 color(n):n is series of Gray Scale
 The more n value is, the bright Gray Scale.
 (2)Data:1-High,0-Low

Correspondence between Data and Display Position

	S0001	S0002	S0003	S0004	S0005	S0006	S0007	S0008	-----	S1919	S1920
C001	R001	G001	B001	R002	G002	B002	R003	G003		G640	B640
C480	R001	G001	B001	R002	G002	B002	R003	G003		G640	B640

10. OPTICAL CHARACTERISTIC

Specification:

Parameter	Symbol	Condition	MIN.	TYP.	MAX.	Unit	Remarks	
Viewing Angle	Horizontal	θ_{x+}	60	70	--	deg	Note 1,4	
		θ_{x-}	60	70	--			
	Vertical	θ_{y+}	Center CR \geq 10	50	60			--
		θ_{y-}		30	40			--
Contrast Ratio	CR	at optimized viewing angle	200	300			Note 1,3	
Response time	Rise	Tr	-	15		ms	Note 1,6	
	Fall	Tf	-	35		ms		
Uniformity		B-uni	$\theta_{x=\theta_{y=0^{\circ}}}$	70	80	--	%	Note1,5
Brightness	L	$\theta_{x=\theta_{y=0^{\circ}}}$ ADJ=3.3V	800	900	--	cd/m ²	Note 1,2	
Chromaticity	x_W	Center $\theta_{x=\theta_{y=0^{\circ}}}$	Typ- 0.05	0.309	Typ+ 0.05		Note 1,7	
	y_W			0.320				
	x_R			0.615				
	y_R			0.360				
	x_G			0.345				
	y_G			0.540				
	x_B			0.148				
	y_B			0.106				
Image sticking	tis	2 hours			2	Sec	Note 8	

The following optical specifications shall be measured in a darkroom or equivalent state (ambient luminance ≤ 1 lux, and at room temperature). The operation temperature is $25^{\circ}\text{C} \pm 2^{\circ}\text{C}$. The measurement method is shown in Note1.

Note1: The method of optical measurement:

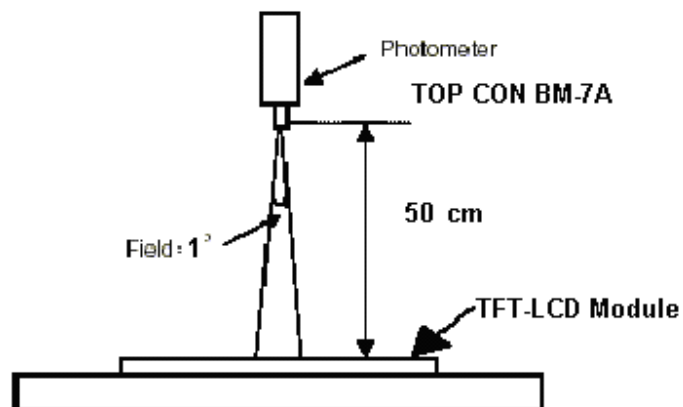

Note2: Measured at the center area of the panel and at the viewing angle of the $\theta_x = \theta_y = 0^\circ$

Note3: Definition of Contrast Ratio (CR):

$$CR = \frac{\text{Luminance with all pixels in white state}}{\text{Luminance with all pixels in Black state}}$$

Note4: Definition of Viewing Angle

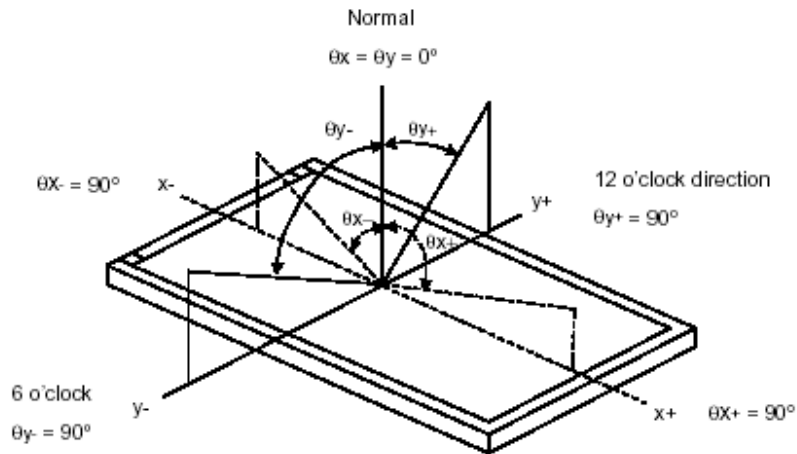

Note 5: Definition of Brightness Uniformity (B-uni):

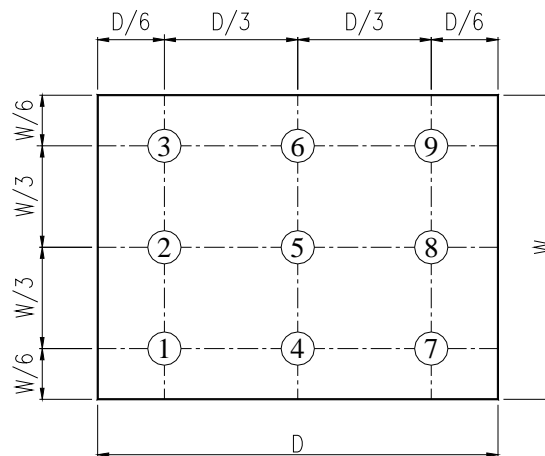

$$B\text{-uni} = \frac{\text{Minimum luminance of 9 points}}{\text{Maximum luminance of 9 points}} \quad (\text{Note 5}).$$

Note6: Definition of Response Time:

The Response Time is set initially by defining the "Rising Time (Tr)" and the "Falling Time (Tf)" respectively. Tr and Tf are defined as following figure.

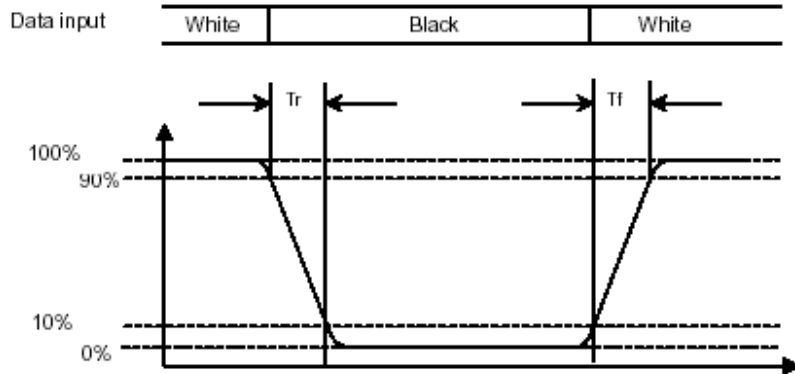

Note 7: Definition of Chromaticity:

The color coordinates (x_w, y_w) , (x_r, y_r) , (x_g, y_g) , and (x_b, y_b) are obtained with all pixels in the viewing field at white, red, green, and blue states, respectively.

Note 8: Definition of Image sticking (tis):

Continuously display the test pattern shown in the figure below for 2 hours. Then display a completely white screen. The previous image shall not persist more than 2 sec at 25 °C

Image sticking pattern

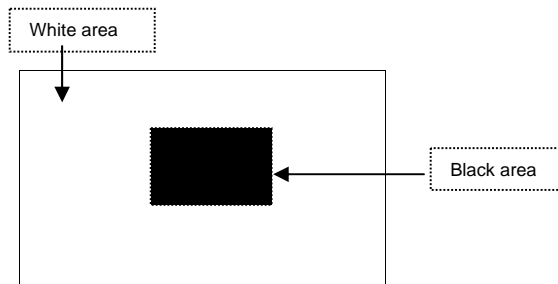

11. QUALITY ASSURANCE

11.1 Test Condition

11.1.1 Temperature and Humidity(Ambient Temperature)

Temperature : $25 \pm 5^{\circ}\text{C}$

Humidity : $65 \pm 5\%$

11.1.2 Operation

Unless specified otherwise, test will be conducted under function state.

11.1.3 Container

Unless specified otherwise, vibration test will be conducted to the product itself without putting it in a container.

11.1.4 Test Frequency

In case of related to deterioration such as shock test. It will be conducted only once.

11.1.5 Test Method

No.	Reliability Test Item & Level	Test Level	Remark
1	High Temperature Storage Test	T=80°C,240hrs	IEC68-2-2
2	Low Temperature Storage Test	T=-30°C,240hrs	IEC68-2-1
3	High Temperature Operation Test	T=70°C,240hrs	IEC68-2-2
4	Low Temperature Operation Test	T=-20°C,240hrs	IEC68-2-1
5	High Temperature and High Humidity Operation Test	T=60°C,90% RH,240hrs	IEC68-2-3
6	Thermal Cycling Test (No operation)	-30°C → +25°C → +80°C,200 Cycles 30 min 5min 30 min	IEC68-2-14
7	Vibration Test (No operation)	Frequency:0 ~ 55 Hz Amplitude:1.5 mm Sweep Time:11min Test Period:6 Cycles for each Direction of X,Y,Z	IEC68-2-6
8	Electrostatic Discharge Test (No operation)	150pF,330Ω Air:± 12KV;Contact: ±6KV 10 times/point;4 points/panel face	IEC-61000-4-2

11.2 Inspection condition

11.2.1 Inspection conditions

11.2.1.1 Inspection Distance : 35 ± 5 cm

11.2.1.2 View Angle : Inspection under test condition : $\pm 5^\circ$

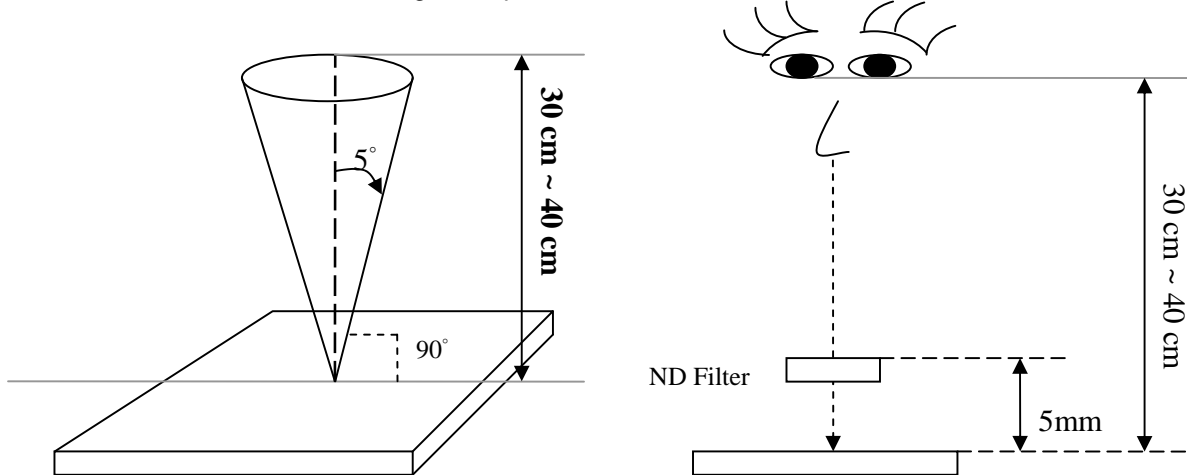

11.1.2 Environment conditions :

Ambient Temperature :		$25 \pm 5^\circ\text{C}$
Ambient Humidity :		$65 \pm 5\%$
Ambient Illumination	Cosmetic Inspection	300 ~ 600 lux
	Functional Inspection	300 ~ 500 lux

11.3 Definition of applicable Zones

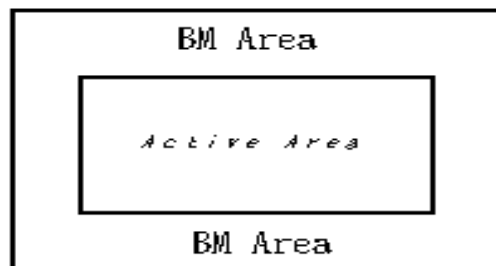

12.4 Inspection Parameters

No.	Parameter	Criteria														
1	Operating	Display function: No Display malfunction (Major)														
		Contrast ratio (Black, White): Does not meet specified range in the spec. (Major) (Note:3)														
		Line Defect: No obvious Vertical and Horizontal line defect in bright, dark and colored. (Major) (Note:1)														
		Point Defect : Active area ≤ 5 dots (Minor) (Note:1)														
		<table border="1"> <thead> <tr> <th rowspan="2">Item</th> <th>Acceptable number</th> <th rowspan="2">Total</th> </tr> <tr> <th>Active Area</th> </tr> </thead> <tbody> <tr> <td>Bright</td> <td>2</td> <td rowspan="2">5</td> </tr> <tr> <td>Dark</td> <td>4</td> </tr> </tbody> </table>	Item	Acceptable number	Total	Active Area	Bright	2	5	Dark	4					
		Item		Acceptable number		Total										
Active Area																
Bright	2	5														
Dark	4															
Non-uniformity: Visible through 5%ND filter. (Minor)																
Foreign material in Black or White spots shape ($W > 1/4L$)																
<table border="1"> <thead> <tr> <th>Zone Dimension</th> <th>Acceptable number</th> <th>Class Of Defects</th> <th>AQL Level</th> </tr> </thead> <tbody> <tr> <td>$D > 0.5$</td> <td>0</td> <td rowspan="3">Minor</td> <td rowspan="3">1.5</td> </tr> <tr> <td>$0.3 < D \leq 0.5$</td> <td>5</td> </tr> <tr> <td>$D \leq 0.3$</td> <td>*</td> </tr> </tbody> </table> <p>$D = (\text{Long} + \text{Short}) / 2$ * : Disregard</p>	Zone Dimension	Acceptable number	Class Of Defects	AQL Level	$D > 0.5$	0	Minor	1.5	$0.3 < D \leq 0.5$	5	$D \leq 0.3$	*				
Zone Dimension	Acceptable number	Class Of Defects	AQL Level													
$D > 0.5$	0	Minor	1.5													
$0.3 < D \leq 0.5$	5															
$D \leq 0.3$	*															
Foreign Material in Line or spiral shape ($W \leq 1/4L$) (Note: 4)																
<table border="1"> <thead> <tr> <th>L (mm) \ W(mm)</th> <th>Zone</th> <th>Acceptable number</th> <th>Class Of Defects</th> <th>AQL Level</th> </tr> </thead> <tbody> <tr> <td>$L > 5$</td> <td>$W > 0.1$</td> <td>0</td> <td rowspan="3">Minor</td> <td rowspan="3">1.5</td> </tr> <tr> <td>$0.5 < L \leq 5$</td> <td>$0.03 < W \leq 0.1$</td> <td>5</td> </tr> <tr> <td>$L \leq 0.5$</td> <td>$W \leq 0.03$</td> <td>*</td> </tr> </tbody> </table> <p>L : Length W : Width * : Disregard</p>	L (mm) \ W(mm)	Zone	Acceptable number	Class Of Defects	AQL Level	$L > 5$	$W > 0.1$	0	Minor	1.5	$0.5 < L \leq 5$	$0.03 < W \leq 0.1$	5	$L \leq 0.5$	$W \leq 0.03$	*
L (mm) \ W(mm)	Zone	Acceptable number	Class Of Defects	AQL Level												
$L > 5$	$W > 0.1$	0	Minor	1.5												
$0.5 < L \leq 5$	$0.03 < W \leq 0.1$	5														
$L \leq 0.5$	$W \leq 0.03$	*														
2	External Inspection (non-operating)	Dimension: Outline (Major)														
		Bezel appearance: uneven (Minor)														
		Scratch on the polarize: (Note:2)														
		<table border="1"> <thead> <tr> <th>L (mm) \ W(mm)</th> <th>Zone</th> <th>Acceptable number</th> <th>Class Of Defects</th> <th>AQL Level</th> </tr> </thead> <tbody> <tr> <td>--</td> <td>$W > 0.1$</td> <td>0</td> <td rowspan="2">Minor</td> <td rowspan="2">1.5</td> </tr> <tr> <td>$L \leq 3$</td> <td>$W \leq 0.1$</td> <td>3</td> </tr> </tbody> </table> <p>L : Length W : Width * : Disregard</p>	L (mm) \ W(mm)	Zone	Acceptable number	Class Of Defects	AQL Level	--	$W > 0.1$	0	Minor	1.5	$L \leq 3$	$W \leq 0.1$	3	
		L (mm) \ W(mm)	Zone	Acceptable number	Class Of Defects	AQL Level										
--	$W > 0.1$	0	Minor	1.5												
$L \leq 3$	$W \leq 0.1$	3														
Dent or bubble on the polarize (Note:2)																
<table border="1"> <thead> <tr> <th>Zone Dimension</th> <th>Acceptable number</th> <th>Class Of Defects</th> <th>AQL Level</th> </tr> </thead> <tbody> <tr> <td>$D \leq 0.3$</td> <td>*</td> <td rowspan="2">Minor</td> <td rowspan="2">1.5</td> </tr> <tr> <td>$D \leq 0.5$</td> <td>3</td> </tr> </tbody> </table> <p>$D = (\text{Long} + \text{Short}) / 2$ * : Disregard</p>	Zone Dimension	Acceptable number	Class Of Defects	AQL Level	$D \leq 0.3$	*	Minor	1.5	$D \leq 0.5$	3						
Zone Dimension	Acceptable number	Class Of Defects	AQL Level													
$D \leq 0.3$	*	Minor	1.5													
$D \leq 0.5$	3															

Class of defects			Definition
	Major	AQL 0.65%	
Minor	AQL 1.5%		It is a defect that will not result in functioning problem with deviation classified.

Note:1.(a)Bright point defect is defined as point defect of R,G,B with area >1/2 dot respectively

(b)Dark point defect is defined as visible in full white pattern.

(c)Definition of distribution of point defect is as follows:

-minumum separation between dark point defects should be larger than 5mm.

-minumum separation between bright point defects should be larger than 5mm.

(d)Definition of joined bright point defect and joined dark point defect are as follows:

-Three or more joined bright point defects must be nil.

-Three joined dark point defects must be nil.

-Coupling of one dark and one bright point in junction is counted as one dark and bright spot with 1 pair maximum.

-Two Joined dark point is counted as two dark point with 2 pair maximum.

(e))Line defect is defined as visible by using 5% ND filter.

Note:2 The external inspection should be conducted at the distance 35 ± 5 cm between the eyes of inspctor and the panel .

Note:3 Luminance measurement for contrast ratio is at the distance 50 ± 5 cm between the detective head and the panel with ambient illuminance less than 1 lux. Contrast ratio is obtained at optimum view angle.

Note:4 W-Width in mm , L-length of Max.(L1,L2) in mm.

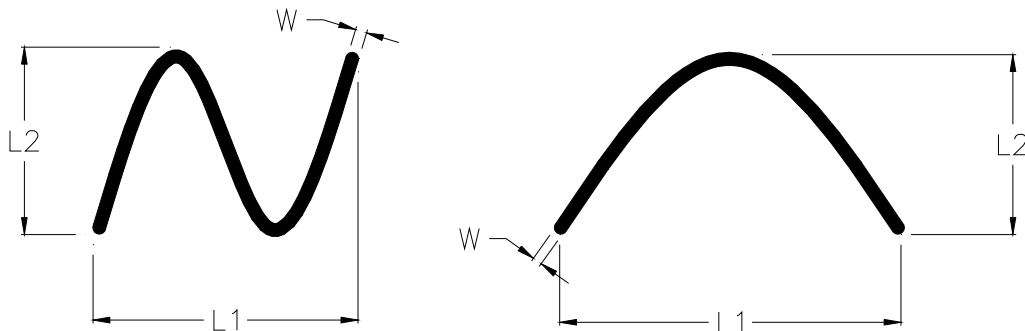

12.5 Sampling Condition

Unless otherwise agree in written, the sampling inspection shall be applied to the incoming inspection of customer.

Lot size: Quantity of shipment lot per model.

Sampling type: normal inspection, single sampling

Sampling table: MIL-STD-105E

Inspection level: Level II

12. LCM PRODUCT LABEL DEFINE

Product Label style:

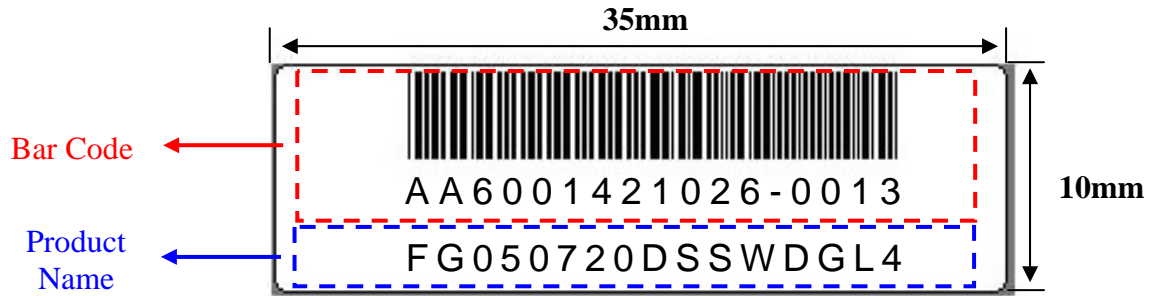

BarCode Define:

A A 6 0014 2 10 26-0013

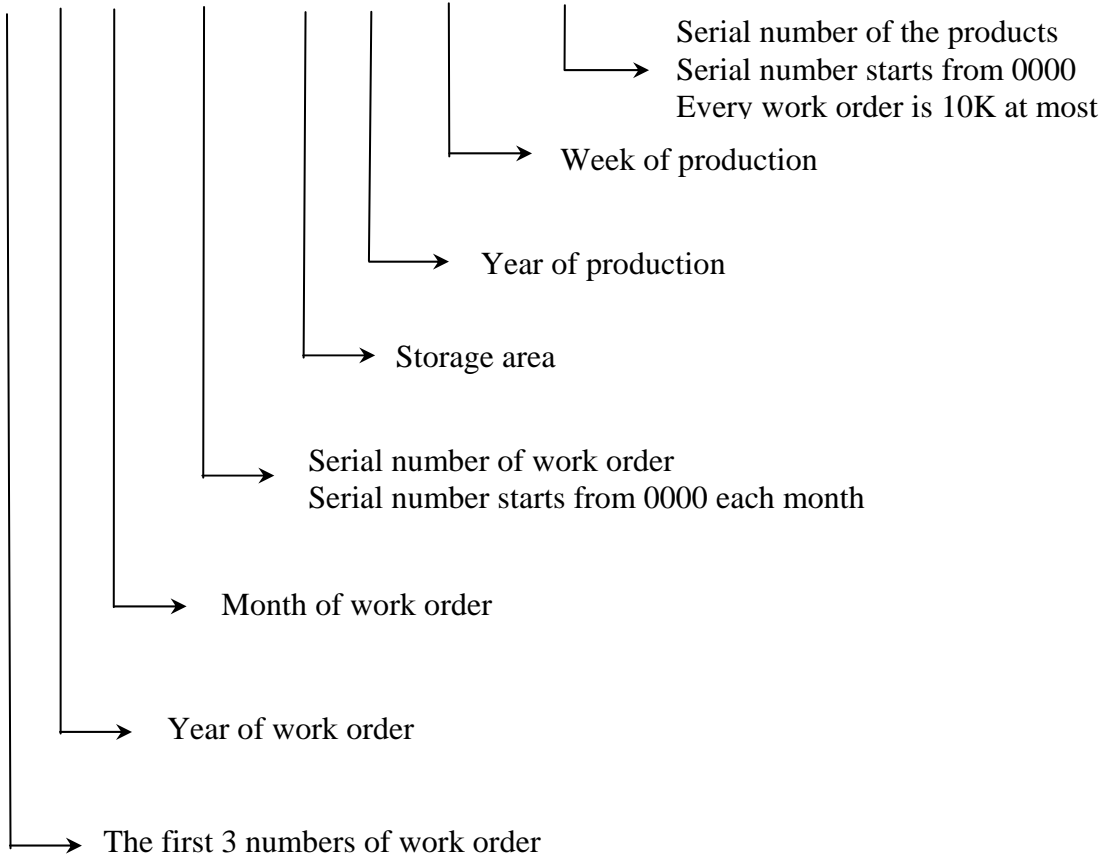

Product Name Define:

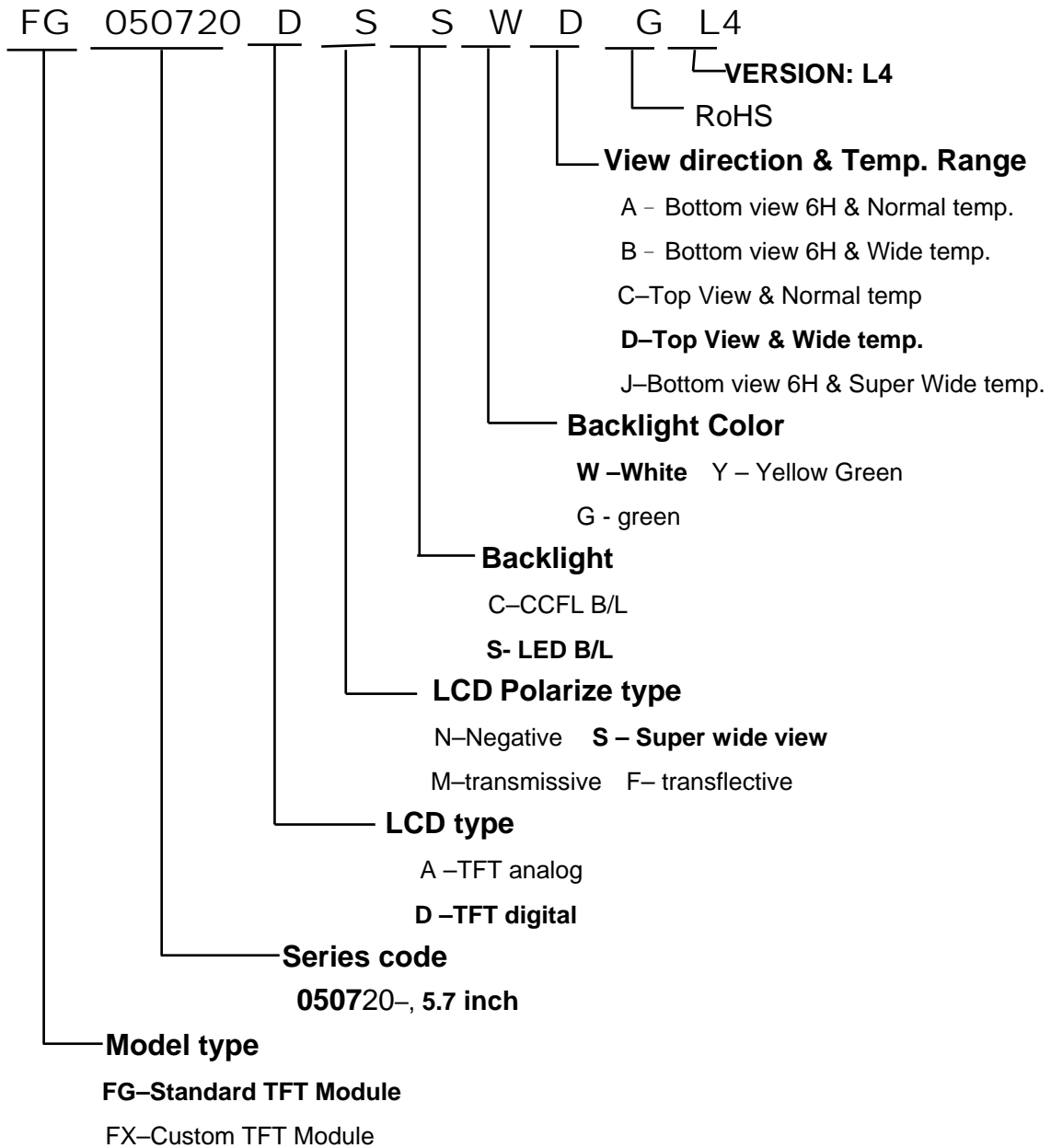

13. PRECAUTION FOR USING LCM

1. ASSEMBLY PRECAUTIONS

- (1) You must mount a module using holes arranged in four corners or four sides.
- (2) You should consider the mounting structure so that uneven force (ex. Twisted stress) is not applied to the module. And the case on which a module is mounted should have sufficient strength so that external force is not transmitted directly to the module.
- (3) Do not touch, push or rub the exposed polarizers with glass, tweezers or anything harder than HB pencil lead. And please do not rub with dust clothes with chemical treatment.
- (4) Wipe off saliva or water drops as soon as possible. Their long time contact with polarizer causes deformations and color fading.
- (5) Do not open the case because inside circuits do not have sufficient strength.
- (6) Please do not take a LCD module to pieces and reconstruct it. Resolving and reconstructing modules may cause them not to work well.
- (7) Please do not touch metal frames with bare hands and soiled gloves. A color change of the metal frames can happen during a long preservation of soiled LCD modules.
- (8) Please pay attention to handling lead wire of backlight so that it is not tugged in connecting with inverter.

2. OPERATING PRECAUTIONS

- (1) Please be sure to turn off the power supply before connecting and disconnecting signal input cable.
- (2) Please do not change variable resistance settings in LCD module. They are adjusted to the most suitable value. If they are changed, it might happen LCD does not satisfy the characteristics specification
- (3) Be careful for condensation at sudden temperature change. Condensation makes damage to polarizer or electrical contacted parts. And after fading condensation, smear or spot will occur.
- (4) When fixed patterns are displayed for a long time, remnant image is likely to occur.
- (5) Module has high frequency circuits. Sufficient suppression to the electromagnetic interference shall be done by system manufacturers. Grounding and shielding methods may be important to minimize the interference.
- (6) Please consider that LCD backlight takes longer time to become stable of radiation characteristics in low temperature than in room temperature.

3. ELECTROSTATIC DISCHARGE CONTROL

- (1) The operator should be grounded whenever he/she comes into contact with the module. Never touch any of the conductive parts such the copper leads on the PCB and the interface terminals with any

parts of the human body.

- (2) The modules should be kept in antistatic bags or other containers resistant to static for storage.
- (3) Only properly grounded soldering irons should be used.
- (4) If an electric screwdriver is used, it should be well grounded and shielded from commutator sparks.
- (5) The normal static prevention measures should be observed for work clothes and working benches; for the latter conductive (rubber) mat is recommended
- (6) Since dry air is inductive to statics, a relative humidity of 50-60% is recommended.

4. STORAGE PRECAUTIONS

- (1) When you store LCDs for a long time, it is recommended to keep the temperature between 0°C-40°C without the exposure of sunlight and to keep the humidity less than 90%RH.
- (2) Please do not leave the LCDs in the environment of high humidity and high temperature such as 60°C 90%RH
- (3) Please do not leave the LCDs in the environment of low temperature; below -20°C.

5. OTHERS

- (1) A strong incident light into LCD panel might cause display characteristics' changing inferior because of polarizer film, color filter, and other materials becoming inferior. Please do not expose LCD module direct sunlight and strong UV rays
- (2) Please pay attention to a panel side of LCD module not to contact with other materials in preserving it alone.
- (3) For the packaging box, please pay attention to the followings:
 - a. Please do not pile them up more than 5 boxes. (They are not designed so.) And please do not turn over.
 - b. Please handle packaging box with care not to give them sudden shock and vibrations. And also please do not throw them up.
 - c. Packing box and inner case for LCDs are made of cardboard. So please pay attention not to get them wet. (Such like keeping them in high humidity or wet place can occur getting them wet.)

6. LIMITED WARRANTY

Unless otherwise agreed between DATA IMAGE and customer, DATA IMAGE will replace or repair any of its LCD and LCM which is found to be defective electrically and visually when inspected in accordance with DATA IMAGE acceptance standards, for a period on one year from date of shipment. Confirmation of such date shall be based on freight documents. The warranty liability of DATA IMAGE is limited to repair and/or replacement on the terms set forth above. DATA IMAGE will not responsible for any subsequent or consequential events.

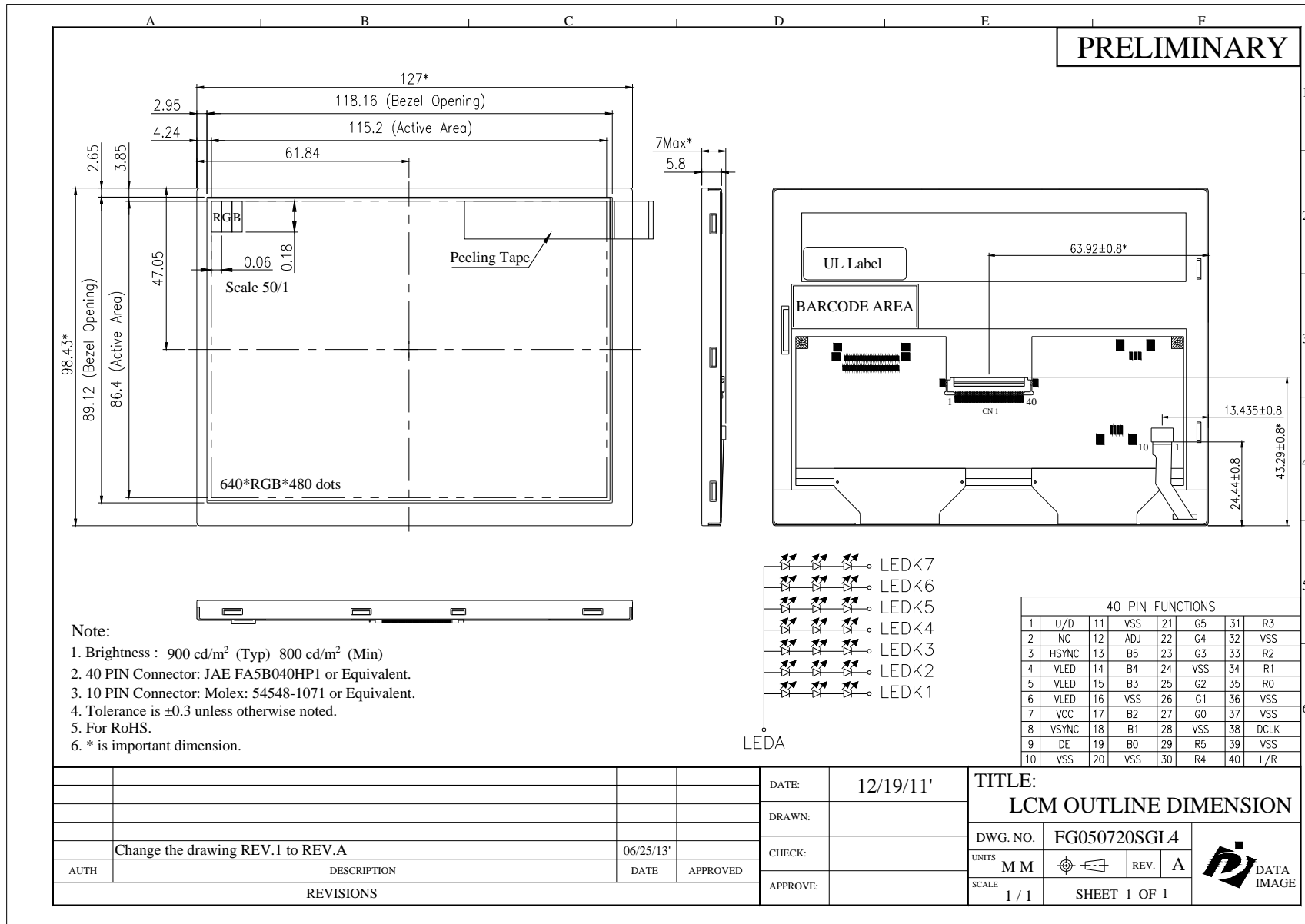
14. OUTLINE DRAWING

15. PACKAGE INFORMATION

