



DATA IMAGE CORPORATION

TFT Module Specification Preliminary

ITEM NO.: FG0500A0DSSWBG01

Table of Contents

1. COVER & CONTENTS	1
2. RECORD OF REVISION	2
3. GENERAL SPECIFICATIONS	3
4. ABSOLUTE MAXIMUM RATINGS.....	3
5. ELECTRICAL CHARACTERISTICS	3
6. TIMING CHARACTERISTICS	5
7. BLOCK DIAGRAM.....	7
8. PIN CONNECTIONS	8
9. OPTICAL CHARACTERISTIC	10
10. QUALITY ASSURANCE	13
11. LCM PRODUCT LABEL DEFINE	14
12. PRECAUTIONS IN USE LCM	16
13. OUTLINE DRAWING	17
14. PACKAGE INFORMATION	18

Customer Companies	R&D Dept.	Q.C. Dept.	Eng. Dept.	Prod. Dept.
	JACK	ERIC	PAUL	HELEN
Approved by	Version:	Issued Date:	Sheet Code:	Total Pages:
	1	7/NOV/10'		18

3. GENERAL SPECIFICATIONS

No.	Item	Specification	Unit	
1	LCD size	5.0 (15 : 9 Diagonal)	inch	
2	Outline Dimension	118.5 × 77.55 × 3.4(Typ.)	mm	
3	Display Area	108.0 (H) × 64.8(V)	mm	
4	Number of Pixel	800(H) × (RGB) × 480 (V)	pixels	
5	Pixel pitch	0.135(H) × 0.135(V)	mm	
6	Pixel arrangement	RGB Vertical stripe		
7	Display mode	Normally white		
8	Surface treatment	Antiglare Hard-Coating(3H)		
9	Weight	66(Typ.)	g	
10	Back-light	LED Side-light type		
11	View direction	6:00		
12	Power Consumption	Logic System	0.7(Max.)	W
		B/L System	0.98(Max.)	W

Remark : Our components and processes are compliant to RoHS standard.

4. ABSOLUTE MAXIMUM RATINGS

Parameter	Symbol	MIN.	MAX.	Unit	Remark
Power supply voltage	VDD	-0.5	5.0	V	GND = 0V
Input signal voltage	Logic input	-0.3	VDD+0.3	V	
Operating temperature	Topa	-20	70	°C	
Storage temperature	T stg	-30	80	°C	

5. ELECTRICAL CHARACTERISTICS

5.1 Typical operation conditions

Ta= 25°C

Parameter	Symbol	MIN.	Typ.	MAX.	Unit	Remark
Power Supply voltage	VDD	3.0	3.3	3.6	V	
Input signal voltage	V _{IH}	0.7*VDD	--	VDD	V	Note 1
	V _{IL}	GND	--	0.3*VDD	V	
Current of Power Supply	IDD	--	--	220	mA	VDD =3.3V

Note:

(1) HSYNC, VSYNC, DE, R/G/B Data (2) GND = 0V

5.2 Backlight Unit

The backlight system is an edge-lighting type with 14 LED

The characteristics of the LED are shown in the following tables.

Ta= 25 °C

Parameter	Symbol	Min	Typ.	Max.	Unit	Remark
LED voltage	V_L	--	23.1	--	V	
LED current	I_L	--	40	--	mA	Note(2)
Operating LED Life Time		10000	--	--	Hour	Note(1)(2)

Note 1: LED life time (Hr) can be defined as the time in which it continues to operate under the condition : Ta = 25 ± 3 , typical IL value indicated in the above table until the brightness becomes less than 50%.

Note 2: The “LED life time” is defined as the module brightness decrease to 50% original brightness at Ta=25 and IL=40mA. The LED lifetime could be decreased if operating IL is larger than 40mA. The constant current driving method is suggested.

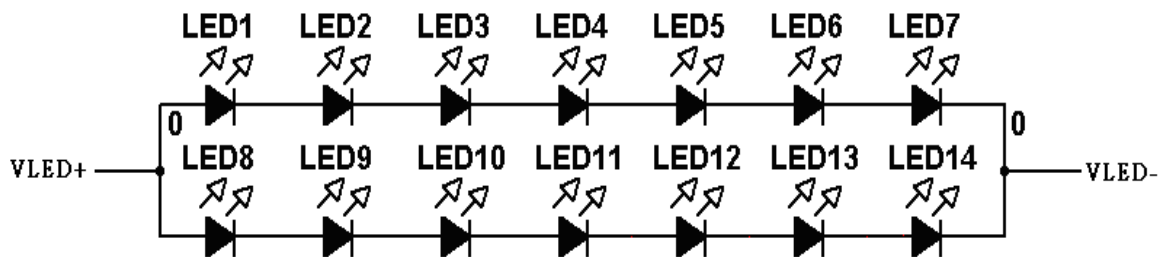

6. Timing Characteristics

Item	Symbol	Min.	Typ.	Max.	Unit	Note
DCLK cycle time	Tclk	25			ns	
DCLK frequency	fclk		33	40	MHz	
DCLK pulse duty	Tcwh	40	50	60	%	
VSYNC setup time	Tvst	8			ns	
VSYNC hold time	Tvhd	8			ns	
HSYNC setup time	Thst	8			ns	
HSYNC hold time	Thhd	8			ns	
Data setup time	Tdasu	8			ns	
Data hold time	Tdahd	8			ns	
DE setup time	Tdesu	8			ns	
DE hold time	Tdehd	8			ns	
Horizontal display area	Thd		800		Tcph	
HSYNC period time	Th		928		Tcph	
HSYNC width	Thwh	1	48		Tcph	
HSYNC back porch	Thbp		40		Tcph	
HSYNC front porch	Thfp		40		Tcph	
Vertical display area	Tvd		480		th	
VSYNC period time	Tv		525		th	
VSYNC width	Tvwh		3		th	
VSYNC back porch	Tvbp		29		th	
VSYNC front porch	Tvfp		13		th	

Timing Diagram of Interface Signal

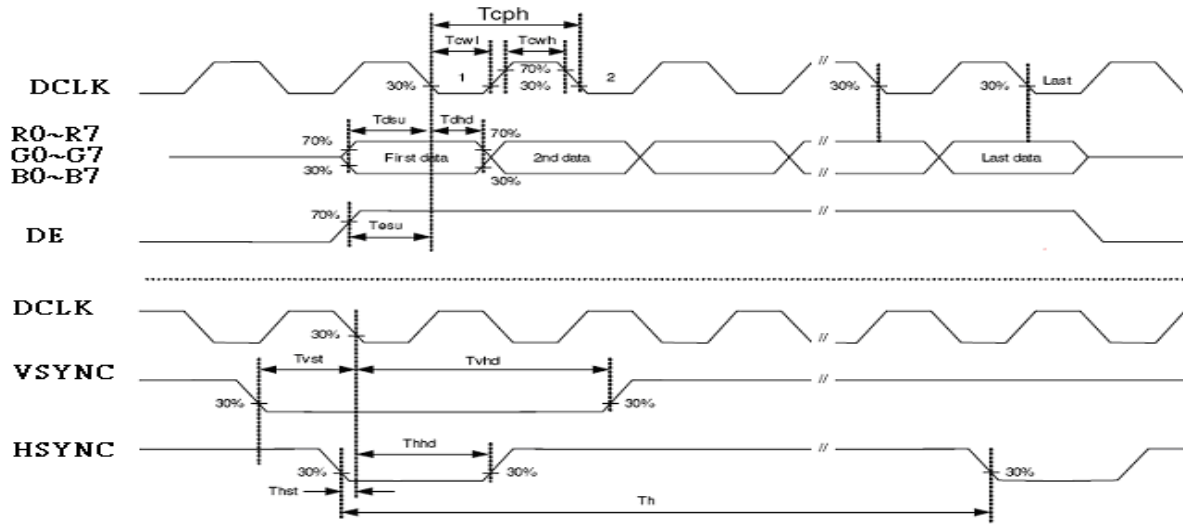

Sampling clock timing

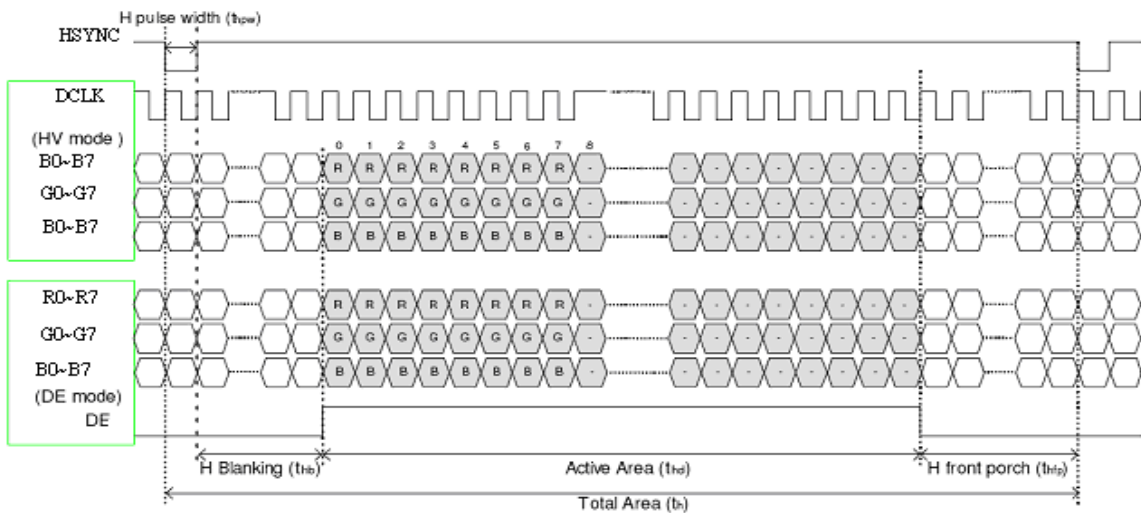

Horizontal display timing range

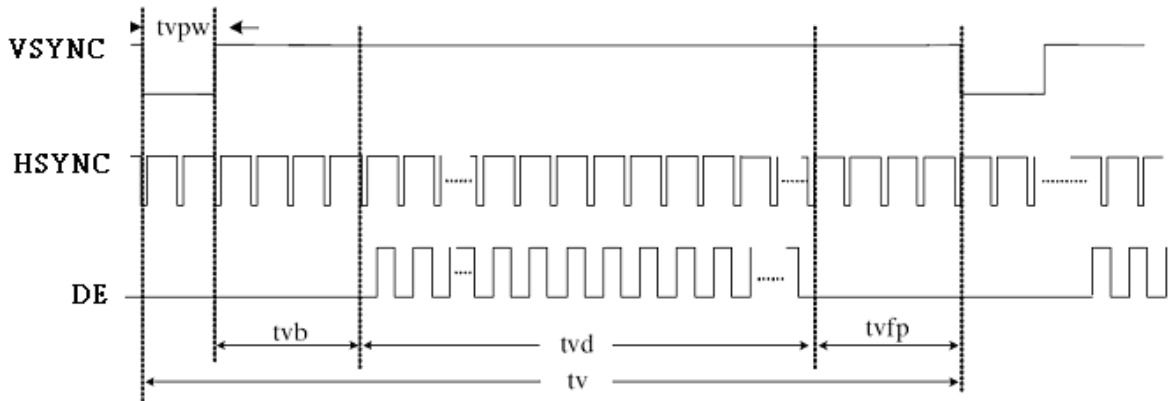

Vertical timing

7.BLOCK DIAGRAM

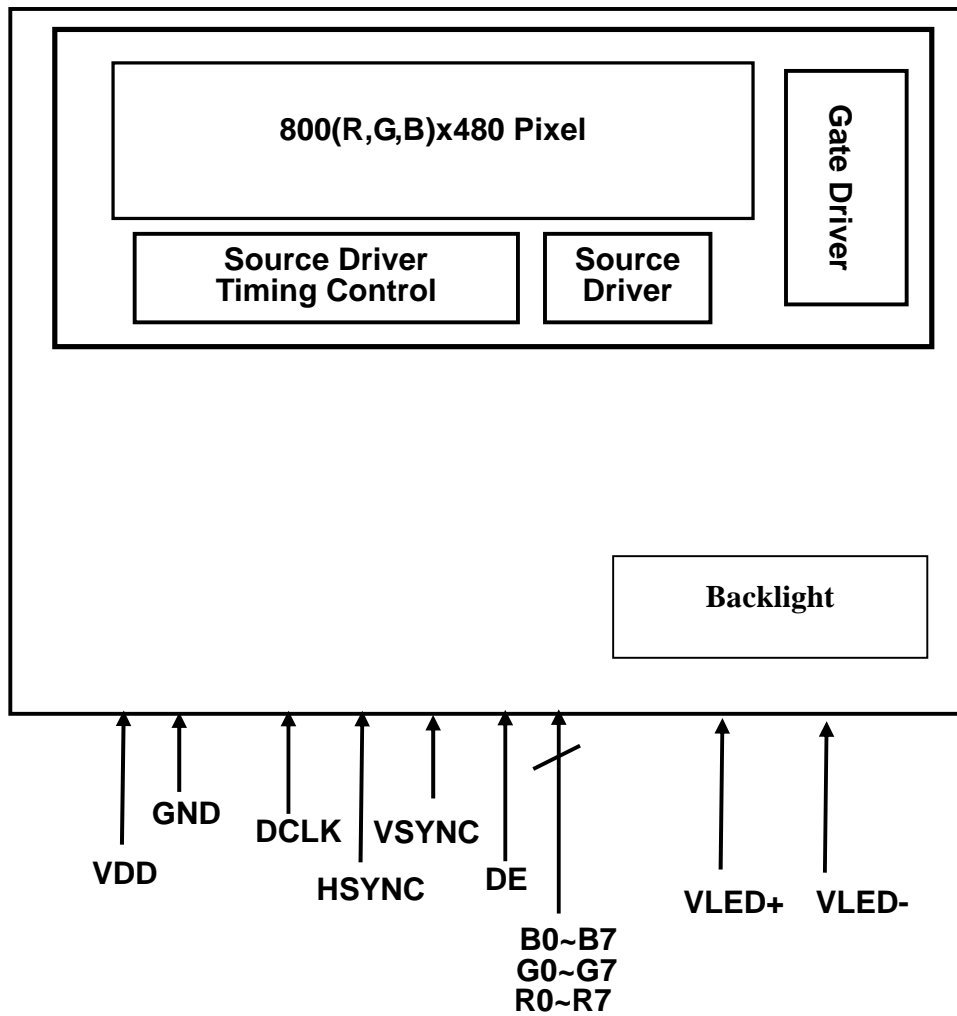

8. PIN CONNECTIONS

8.1 Input Pins Function

Pin No.	Symbol	I/O	Function
1	VLED-	P	Power for LED backlight cathode
2	VLED+	P	Power for LED backlight anode
3	GND	P	Power ground
4	VDD	P	Power voltage
5	R0	I	Red data (LSB)
6	R1	I	Red data
7	R2	I	Red data
8	R3	I	Red data
9	R4	I	Red data
10	R5	I	Red data
11	R6	I	Red data
12	R7	I	Red data (MSB)
13	G0	I	Green data (LSB)
14	G1	I	Green data
15	G2	I	Green data
16	G3	I	Green data
17	G4	I	Green data
18	G5	I	Green data
19	G6	I	Green data
20	G7	I	Green data (MSB)
21	B0	I	Blue data (LSB)
22	B1	I	Blue data
23	B2	I	Blue data
24	B3	I	Blue data
25	B4	I	Blue data
26	B5	I	Blue data
27	B6	I	Blue data
28	B7	I	Blue data (MSB)
29	DGND	P	Digital ground
30	DCLK	I	Pixel clock
31	DISP	I	Display on/ off
32	HSYNC	I	Horizontal sync signal
33	VSYNC	I	Vertical sync signal
34	DE	I	Data enable
35	NC	-	No Connect
36	GND	P	Power ground
37	NC	-	No Connect
38	NC	-	No Connect
39	NC	-	No Connect
40	NC	-	No Connect

I/O:I: input, O: output, P: Power

8.2 Power Sequence

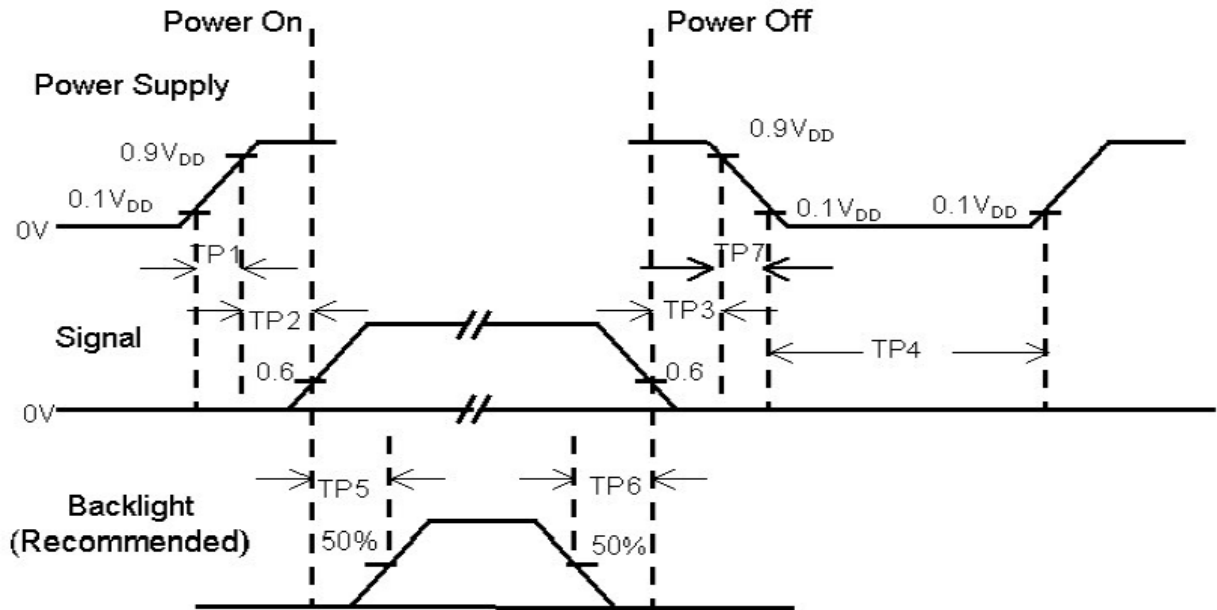

Item	Min.	Typ.	Max.	Unit	Remark
TP1	0.5	--	10	msec	
TP2	0	--	50	msec	
TP3	0	--	50	msec	
TP4	1000	--	--	msec	
TP5	200	--	--	msec	
TP6	200	--	--	msec	
TP7	0.5	--	10	msec	

Note:

(1) The supply voltage of the external system for the module input should be the same as the definition of VDD.

(2) Apply the lamp voltage within the LCD operation range. When the back-light turns on before the LCD operation or the LCD turns off before the back-light turns off, the display may momentarily become white.

(3) In case of VDD = off level, please keep the level of input signal on the low or keep a high impedance.

(4) TP4 should be measured after the module has been fully discharged between power off and on period.

(5) Interface signal shall not be kept at high impedance when the power is on.

9. OPTICAL CHARACTERISTIC

Specification:

Item		Symbol	Condition	Min.	Typ.	Max.	Unit	Remark
Response time	Rise	TON	Normal $\theta=\Phi=0^\circ$	-	2	4	ms	Note3 , 4
	Fall	TOFF		-	6	12	ms	
Contrast ratio		CR			480	600		
Viewing angle	L	$=180^\circ$ (9 o ' clock)		65	75	-	Deg.	Note 1 , 4
	R	$=0^\circ$ (3 o ' clock)		65	75	-		
	U	$=90^\circ$ (12 o ' clock)		50	60	-		
	D	$=270^\circ$ (6 o ' clock)		60	70	-		
Brightness (Center)			Normal $\theta=\Phi=0^\circ$	320	400	--	cd/m ²	Note 4 , 6
Uniformity				70	--	--	%	Note 4 , 5 , 6
Color chromaticity (CIE1931)	White	X		0.26	0.31	0.36		Note 4 , 6
		y	0.28	0.33	0.38			

Test Conditions:

Measuring surrounding: dark room
 LED current IL: 40mA
 Ambient temperature: $25\pm 2^\circ\text{C}$
 15 min. warm-up time.

Note (1): Definition of viewing angle range

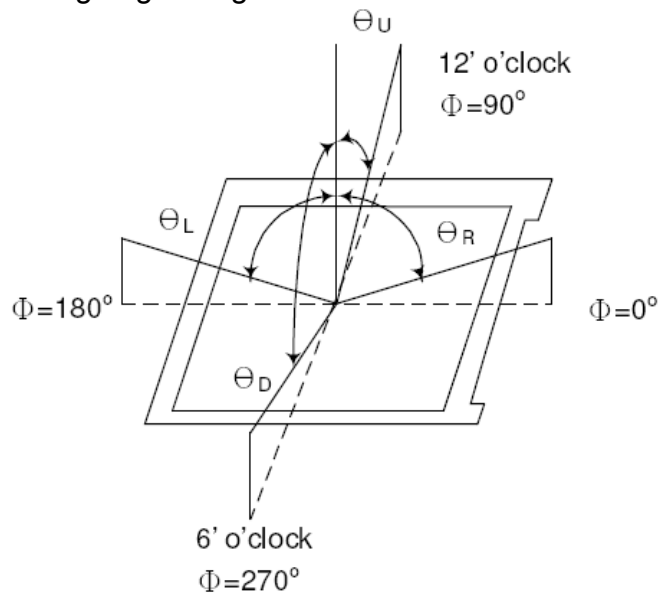

Note (2) Definition of Contrast Ratio (CR):
 Measured at the center point of panel

$$CR = \frac{\text{Luminance with all pixels white}}{\text{Luminance with all pixels black}}$$

Note (3) Definition of Response Time: Sum of T_{OFF} and T_{ON}

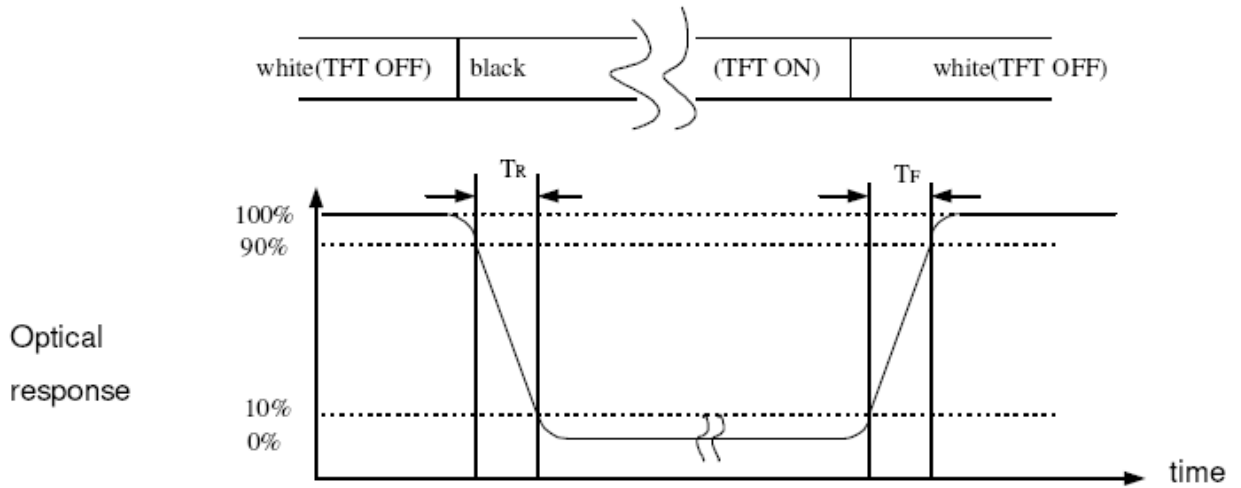

Note (4) The method of optical measurement:

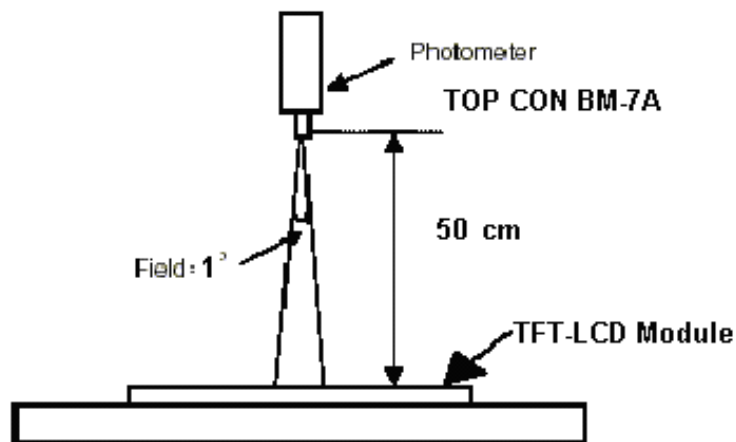

Note (5) Definition of brightness uniformity

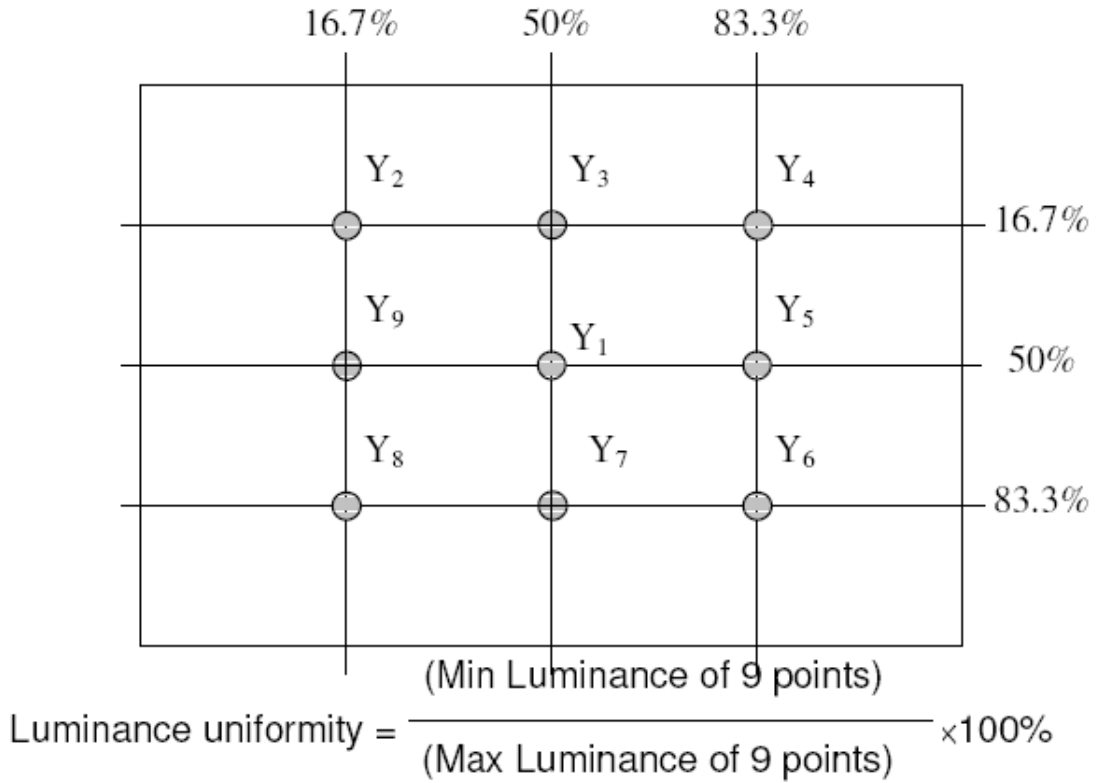

Note (6) Measured at the center area of the panel when all terminals of LCD panel are electrically open.

10. QUALITY ASSURANCE

No.	Item	Test Conditions	Remark
1	High Temperature Storage	Ta = 80 240 hrs	Note 1, 3
2	Low Temperature Storage	Ta = -30 240hrs	Note 1, 3
3	High Temperature Operation	Ta = 70 240hrs	Note 1, 3
4	Low Temperature Operation	Ta = -20 240hrs	Note 1, 3
5	Operate at High Temperature and Humidity	+60 , 90%RH 240 hrs	Note 3
6	Thermal Cycling Test (non operation)	-30 (30 min) + 80 (30 min), 200 cycles	Note 3
7	Vibration Test	1 Random: 1.04Grrms,5~500HZ, X/Y/X 30min/each direction 2 Sine: Freq. Range:8~33.3Hz Stoke:1.3mm Sweep:2.9G,33.3~400Hz X/Z:2hr,Y:4hr cyc:15min	
8	Mechanical Shock	100G 6ms,±X, ±Y, ±Z 3 times for each direction	JIS C7021, A-10 (Condition A)
9	Vibration Test(with carton)	Random Vibration : 0.015G ² /Hz from 5-200HZ, -6dB/Octave from 200-400HZ 2 hours for each direction of X. Y. Z.	
10	Drop Test(with carton)	Height:60 cm 1 corner, 3 edges, 6 surfaces	JIS Z0202
11	Electro Static Discharge	± 200V, 200Pf(0Ω) 1 time/each terminal	

Note 1: Ta is the ambient temperature of samples.

Note 2: In the standard condition, there shall be no practical problem that may affect the display function. After the reliability test, the product only guarantees operation, but doesn't guarantee all the cosmetic specification.

Note 3: Before cosmetic and function tests, the product must have enough recovery time, at least 2 hours at room temperature.

11. LCM PRODUCT LABEL DEFINE

Product Label style:

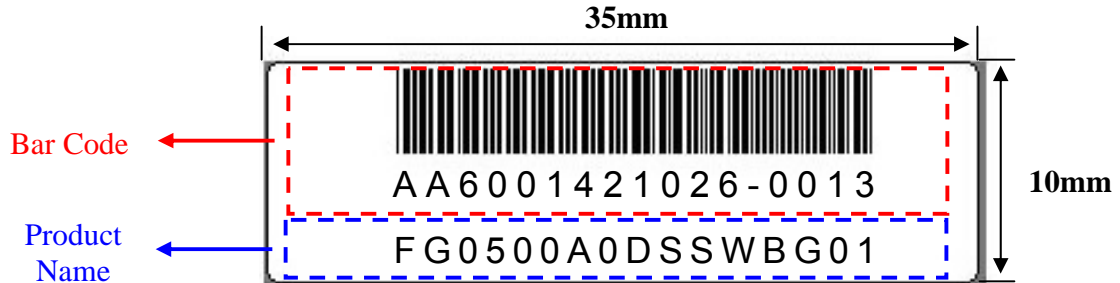

BarCode Define:

A A 6 0014 2 10 26-0013

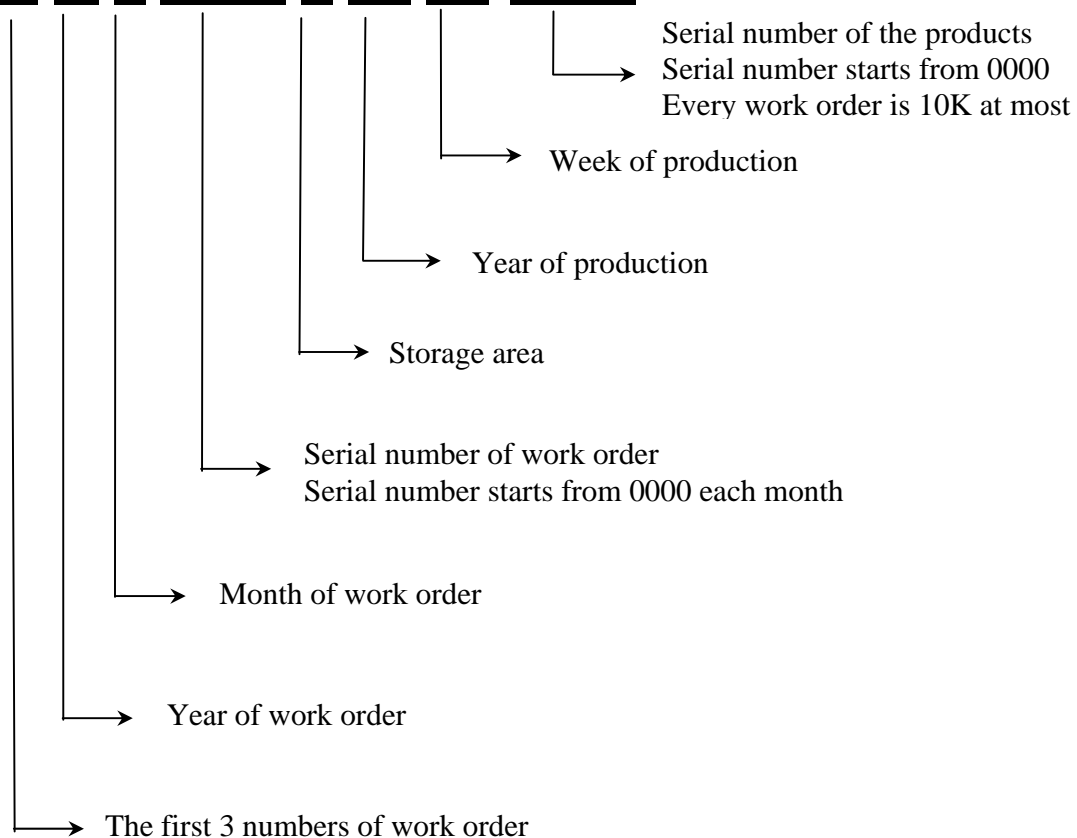

Product Name Define:

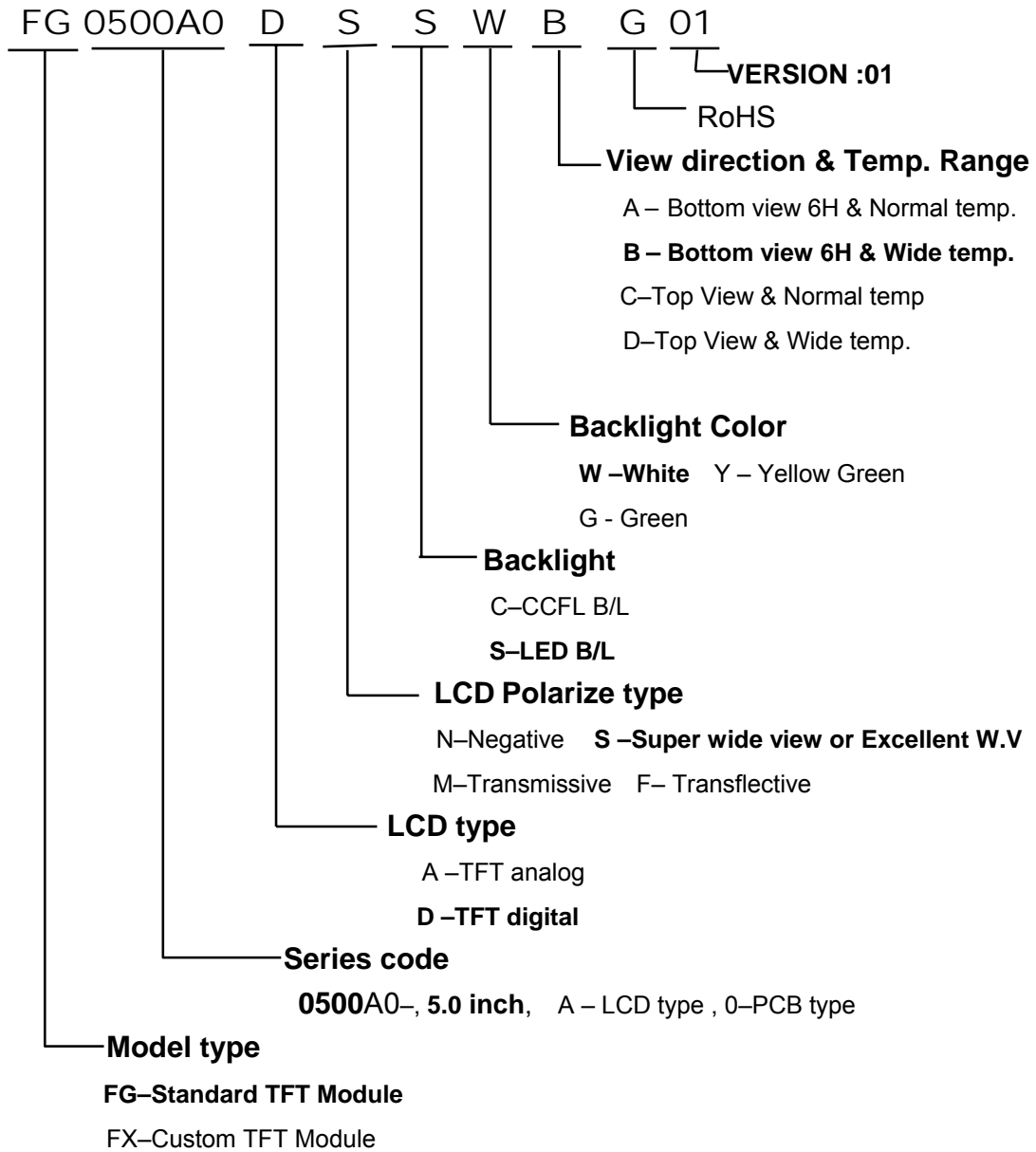

12. PRECAUTIONS IN USE LCM

1. LIQUID CRYSTAL DISPLAY (LCD)

LCD is made up of glass, organic sealant, organic fluid, and polymer based polarizers. The following precautions should be taken when handling,

- (1). Keep the temperature within range of use and storage. Excessive temperature and humidity could cause polarization degradation, polarizer peel off or bubble.
- (2). Do not contact the exposed polarizers with anything harder than an HB pencil lead. To clean dust off the display surface, wipe gently with cotton, chamois or other soft material soaked in petroleum benzin.
- (3). Wipe off saliva or water drops immediately. Contact with water over a long period of time may cause polarizer deformation or color fading, while an active LCD with water condensation on its surface will cause corrosion of ITO electrodes.
- (4). Glass can be easily chipped or cracked from rough handling, especially at corners and edges.
- (5). Do not drive LCD with DC voltage.

2. Liquid Crystal Display Modules

2.1 Mechanical Considerations

LCM are assembled and adjusted with a high degree of precision. Avoid excessive shocks and do not make any alterations or modifications. The following should be noted.

- (1). Do not tamper in any way with the tabs on the metal frame.
- (2). Do not modify the PCB by drilling extra holes, changing its outline, moving its components or modifying its pattern.
- (3). Do not touch the elastomer connector, especially insert an backlight panel (for example, EL).
- (4). When mounting a LCM make sure that the PCB is not under any stress such as bending or twisting. Elastomer contacts are very delicate and missing pixels could result from slight dislocation of any of the elements.
- (5). Avoid pressing on the metal bezel, otherwise the elastomer connector could be deformed and lose contact, resulting in missing pixels.

2.2. Static Electricity

LCM contains CMOS LSI's and the same precaution for such devices should apply, namely

- (1). The operator should be grounded whenever he/she comes into contact with the module. Never touch any of the conductive parts such as the LSI pads, the copper leads on the PCB and the interface terminals with any parts of the human body.
- (2). The modules should be kept in antistatic bags or other containers resistant to static for storage.
- (3). Only properly grounded soldering irons should be used.
- (4). If an electric screwdriver is used, it should be well grounded and shielded from commutator sparks.

- (5) The normal static prevention measures should be observed for work clothes and working benches; for the latter conductive (rubber) mat is recommended.
- (6). Since dry air is inductive to statics, a relative humidity of 50-60% is recommended.

2.3 Soldering

- (1). Solder only to the I/O terminals.
- (2). Use only soldering irons with proper grounding and no leakage.
- (3). Soldering temperature : $280^{\circ}\text{C} \pm 10^{\circ}\text{C}$
- (4). Soldering time: 3 to 4 sec.
- (5). Use eutectic solder with resin flux fill.
- (6). If flux is used, the LCD surface should be covered to avoid flux spatters. Flux residue should be removed after wards.

2.4 Operation

- (1). The viewing angle can be adjusted by varying the LCD driving voltage V_0 .
- (2). Driving voltage should be kept within specified range; excess voltage shortens display life.
- (3). Response time increases with decrease in temperature.
- (4). Display may turn black or dark blue at temperatures above its operational range; this is (however not pressing on the viewing area) may cause the segments to appear "fractured".
- (5). Mechanical disturbance during operation (such as pressing on the viewing area) may cause the segments to appear "fractured".

2.5 Storage

If any fluid leaks out of a damaged glass cell, wash off any human part that comes into contact with soap and water. Never swallow the fluid. The toxicity is extremely low but caution should be exercised at all the time.

2.6 Limited Warranty

Unless otherwise agreed between DATA IMAGE and customer, DATA IMAGE will replace or repair any of its LCD and LCM which is found to be defective electrically and visually when inspected in accordance with DATA IMAGE acceptance standards, for a period on one year from date of shipment. Confirmation of such date shall be based on freight documents. The warranty liability of DATA IMAGE is limited to repair and/or replacement on the terms set forth above. DATA IMAGE will not responsible for any subsequent or consequential events.

13. OUTLINE DRAWING

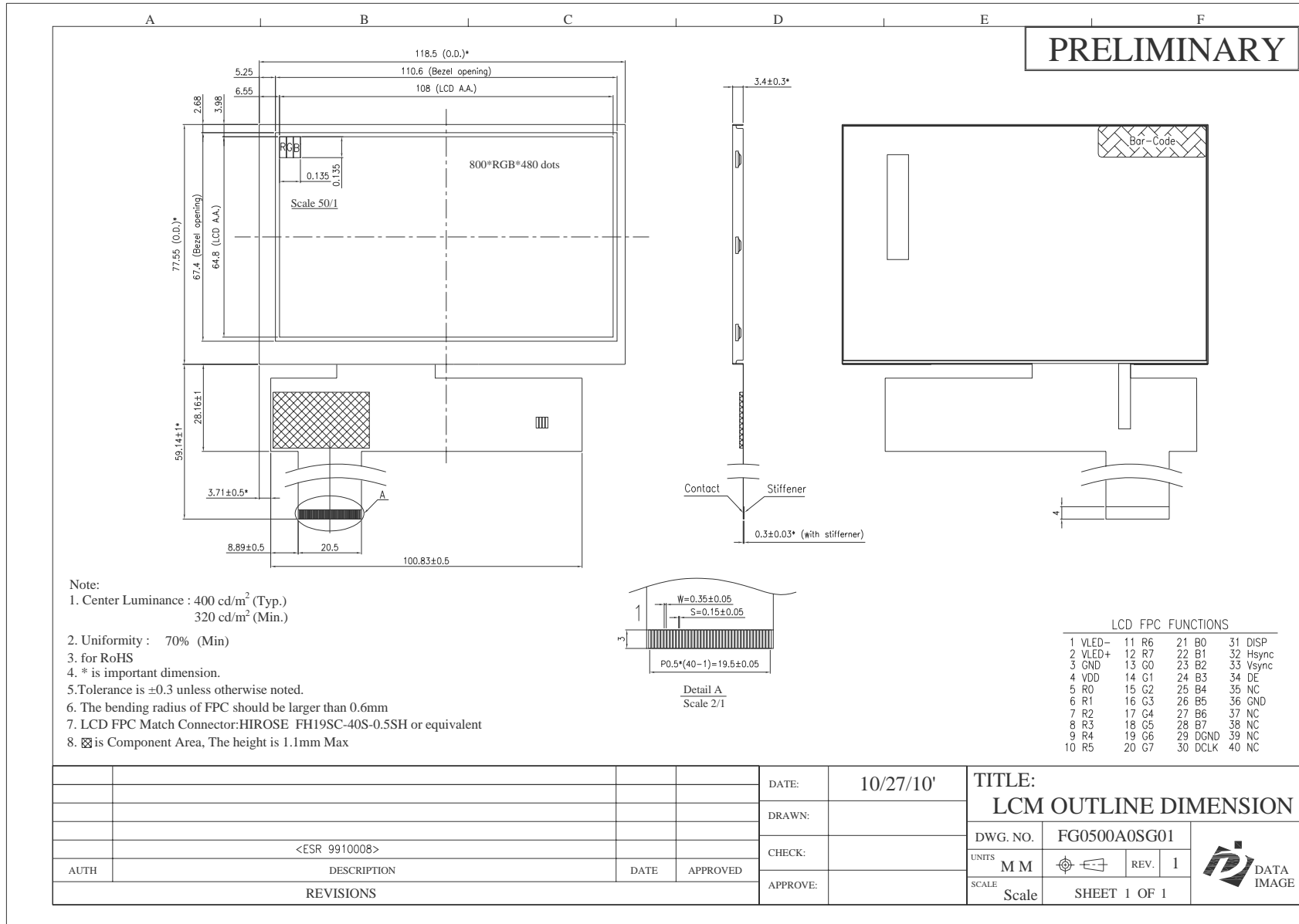

14. PACKAGE INFORMATION

TBD