

# DATA IMAGE CORPORATION

## TFT Module Specification

ITEM NO.: **FG0208J0DSSWDG01**

### Table of Contents

1. COVER & CONTENTS .....	1
2. RECORD OF REVISION .....	2
3. GENERAL SPECIFICATIONS .....	3
4. ABSOLUTE MAXIMUM RATINGS .....	3
5. ELECTRICAL CHARACTERISTICS .....	3
6. PIN CONNECTIONS .....	4
7. BLOCK DIAGRAM .....	5
8. AC CHARACTERISTICS .....	6
9. OPTICAL CHARACTERISTICS .....	11
10. APPEARANCE SPECIFICATIONS FOR VERIFONE .....	13
11. QUALITY ASSURANCE .....	16
12. LCM PRODUCT LABEL DEFINE .....	17
13. PRECAUTIONS IN USE LCM .....	19
14. OUTLINE DRAWING .....	20
15. PACKAGE INFORMATION .....	21

Customer Companies	R&D Dept.	Q.C. Dept.	Eng. Dept.	Prod. Dept.
	<i>Alex</i>	<i>pretty</i>	<i>David</i>	<i>Iden</i>
Approved by	Version:	Issued Date:	Sheet Code:	Total Pages:
	A	22/JAN/15'		21



### 3. GENERAL SPECIFICATIONS

Parameter	Specifications	Unit	
Screen Size	2.8" (diagonal)	inch	
Pixel configuration	RGB Stripe		
Display Format	240(RGB) X 320	Dot	
Active Area	57.6(W) x43.2 (H)	mm	
Pixel Size	0.18(W) x0.18(H)	mm	
Outline Dimension	67(W)x49(H)x2.8(T)	mm	
Viewing direction(Gray inversion)	12 o'clock		
Weight	16	g	
Surface Treatment	Clear		
Temperature Range	Operation	-20~70	°C
	Storage	-30~80	°C

Our components and processes are compliant to RoHS and REACH standard

### 4. ABSOLUTE MAXIMUM RATINGS

Parameter	Symbol	MIN.	Typ.	MAX.	Unit	Comment
Power supply Voltage	VDD	-0.3	--	+4.6	V	Notes 1,2
Logic Input Voltage	V <sub>IN</sub>	-0.3	--	VDD+0,5	V	

Notes:

1. If the LSI is used above these absolute maximum ratings, it may become permanently damaged. Using the LSI within the following electrical characteristics limit is strongly recommended for normal operation. If these electrical characteristic conditions are also exceeded, the LSI will malfunction and cause poor reliability.
2. VDD, GND must be maintained.

### 5. ELECTRICAL CHARACTERISTICS

GND=0V, Ta=25°C

Item	Symbol	Min.	Typ.	Max.	Unit	Remark
Power Supply Voltage	VDD	2.3	-	3.3	V	
Input high voltage	V <sub>IH</sub>	0.7VDD	--	VDD	V	
Input low voltage	V <sub>IL</sub>	0	--	0.3VDD	V	
Current consumption	IDD	--	5	--	mA	

### 5.1. Backlight driving for power conditions

Item	Symbol	Min.	Typical	Max.	Unit	Remark
LED module Forward voltage	VLED	--	12.4	--	V	
LED module current	ILED	--	20	--	mA	
LED life time		10,000	--	--	Hours	Note 1

Note 1 The “LED dice life time” is defined as the brightness decrease to 50% original brightness that the ambient temperature is 22 and LED dice current=20mA.

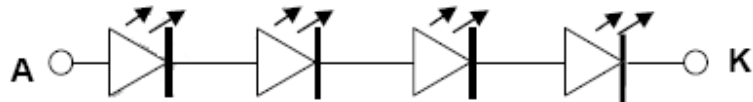

## 6. PIN CONNECTIONS

Pin No	Symbol	Description
1	GND	Ground
2	GND	Ground
3	GND	Ground
4	TAMPER	Wire to pin 42
5	GND	Ground
6	VDD	power source
7	VDD	power source
8	/CS	Chip select pin
9	SCL	SCL : SPI clock signal
10	SDI	SPI input pin
11	SDO	SPI output pin
12	GND	Ground
13~18	B(0~5)	Blue data
19	GND	Ground
20~25	G(0~5)	Green data
26	GND	Ground
27~32	R(0~5)	Red data
33	GND	Ground
34	LCD_DOE	Data ENABLE signal
35	GND	Ground
36	LCD_CLK	Dot clock signal
37	GND	Ground
38	LCD_HSYNC	Line synchronizing signal
39	LCD_VSYNC	Frame synchronizing signal
40	/RESET	System Reset signal
41	GND	Ground
42	TAMPER_Signal	Wire to pin 4
43	A	LED anode (A)
44	K	LED cathode (K)
45	GND	Ground

## 7. BLOCK DIAGRAM

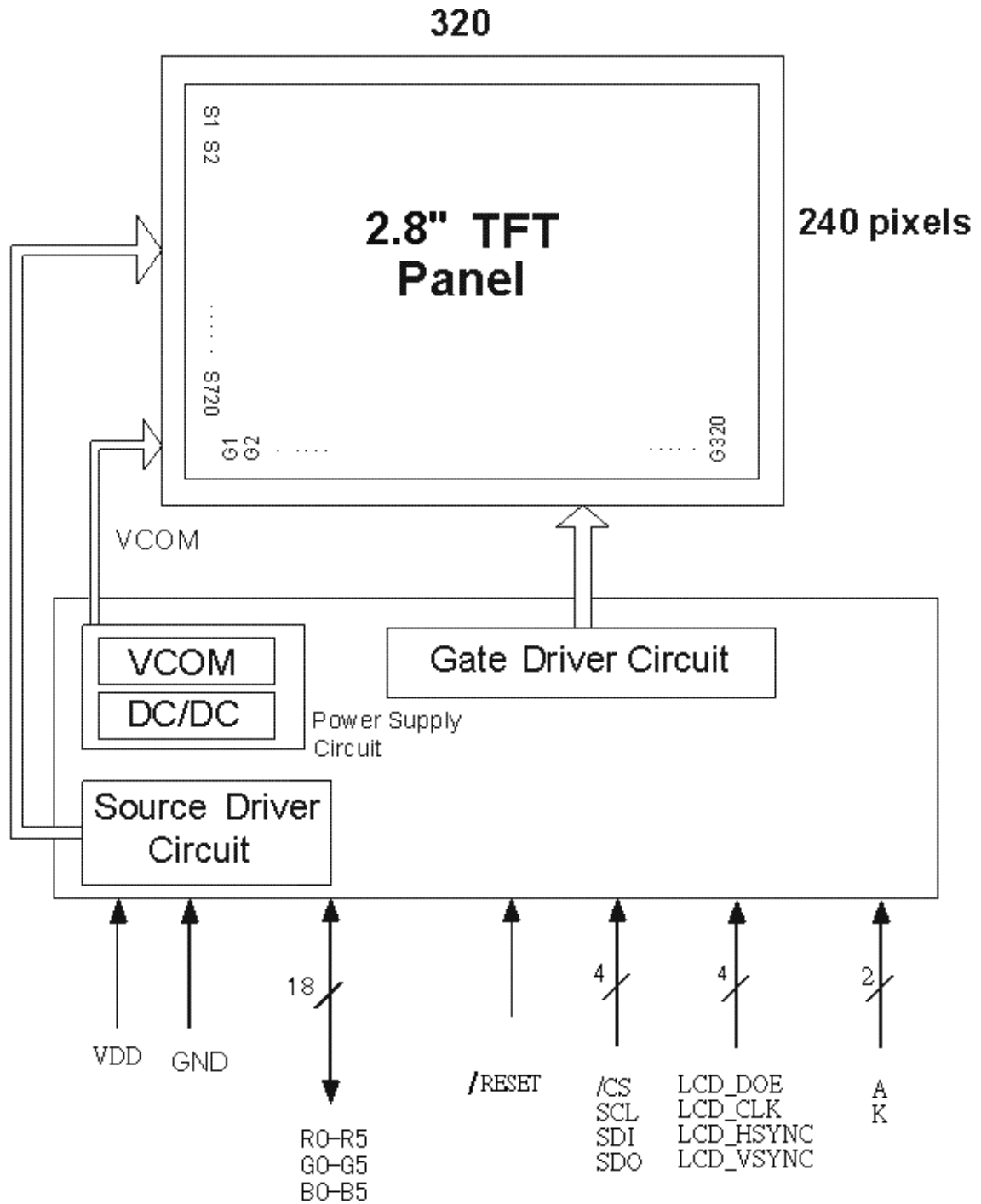

## 8. AC Characteristics

### 8.1 Serial Interface Characteristics

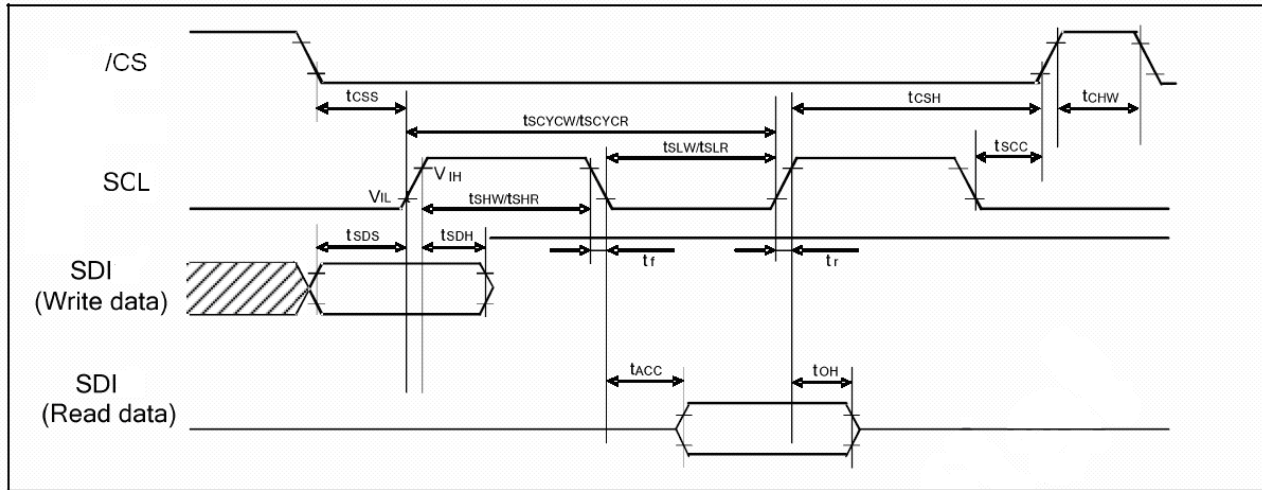
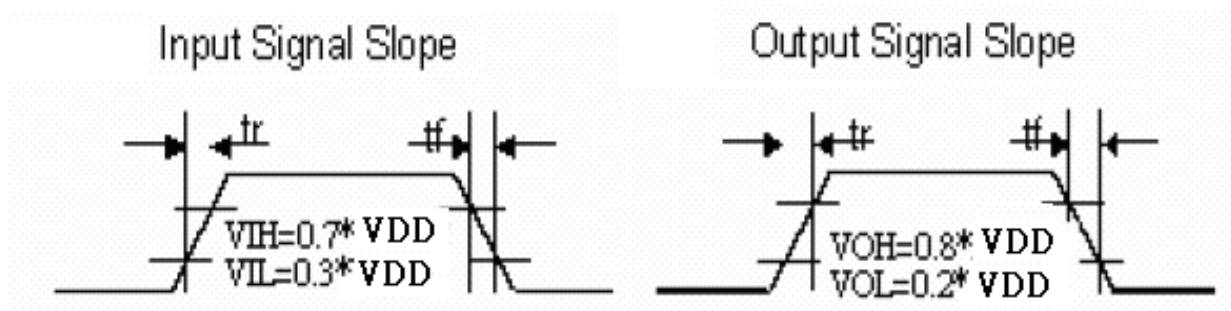

Figure 8.1.1 Serial Interface Characteristics

Parameter	Symbol	Conditions	Min.	Typ.	Max.	Unit
Serial clock cycle (Write)	$t_{SCYCW}$		20	-	-	
SCL "H" pulse width (Write)	$t_{SHW}$	SCL	8	-	-	ns
SCL "L" pulse width (Write)	$t_{SLW}$	SCL	8	-	-	ns
Data setup time (Write)	$t_{SDS}$	SDIO	10	-	-	ns
Data hold time (Write)	$t_{SDH}$	SDIO	10	-	-	ns
Serial clock cycle (Read)	$t_{SCYCR}$		150	-	-	
SCL "H" pulse width (Read)	$t_{SHR}$	SCL	60	-	-	ns
SCL "L" pulse width (Read)	$t_{SLR}$	SCL	60	-	-	ns
Access Time	$t_{ACC}$	SDI for maximum $C_L=30pF$ For minimum $C_L=8pF$	10	-	50	ns
Output disable time	$t_{OH}$	SDO For maximum $C_L=30pF$ For minimum $C_L=8pF$	15	-	50	ns
SCL to Chip select	$t_{SCC}$	SCL.NCS	20	-	-	ns
NCS "H" pulse width	$t_{CHW}$	NCS	40	-	-	ns
Chip select setup time	$t_{CSS}$	NCS	15	-	-	ns
Chip select hold time	$t_{CSH}$	NCS	15	-	-	ns

**Note:** The input signal rise time and fall time ( $t_r$ ,  $t_f$ ) is specified at 15 ns or less.

Logic high and low levels are specified as 30% and 70% of VDD for Input signals.



## 8.2 RGB Interface Characteristics

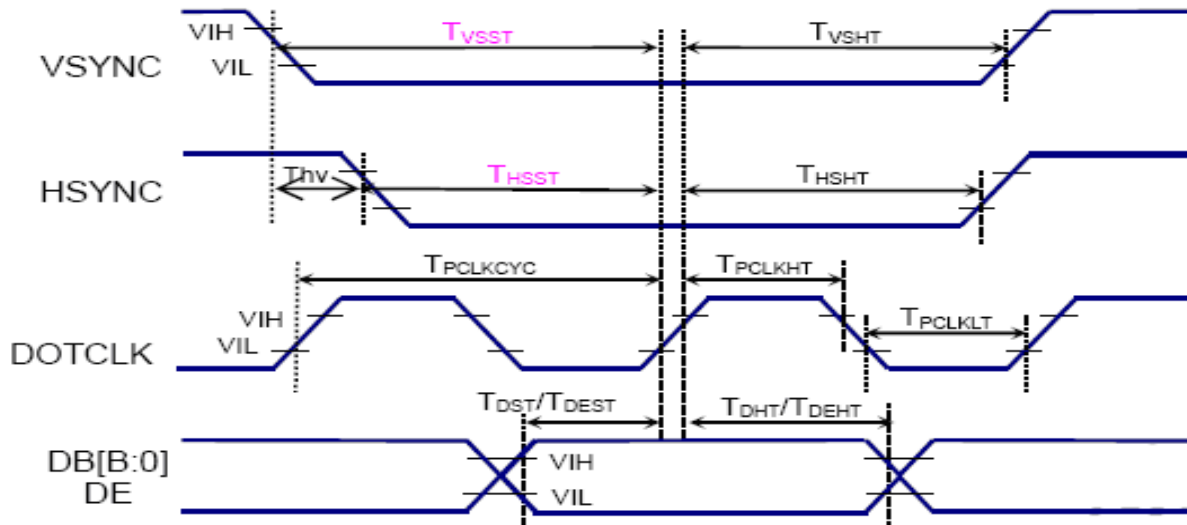
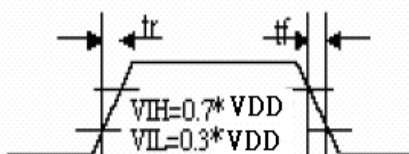

Figure 8. 2.1 RGB Interface Characteristics

Item	Symbol	Spec.			Unit
		Min	Type.	Max	
Pixel low pulse width	TCLKLT	15	-	-	ns
Pixel high pulse width	TCLKHT	15	-	-	ns
Vertical Sync. set-up time	TVSSST	15	-	-	ns
Vertical Sync. hold time	TVSSH T	15	-	-	ns
Horizontal Sync. set-up time	THSST	15	-	-	ns
Horizontal Sync. hold time	THSSH T	15	-	-	ns
Data Enable set-up time	TDEST	15	-	-	ns
Data Enable hold time	TDEHT	15	-	-	ns
Data set-up time	TDST	15	-	-	ns
Data hold time	TDHT	15	-	-	ns
Phase difference of sync signal falling edge	Thv	0	-	240	Dotclk

**Note:** The input signal rise time and fall time ( $t_r$ ,  $t_f$ ) is specified at 15 ns or less.

Input Signal Slope



Output Signal Slope

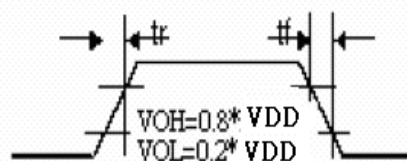

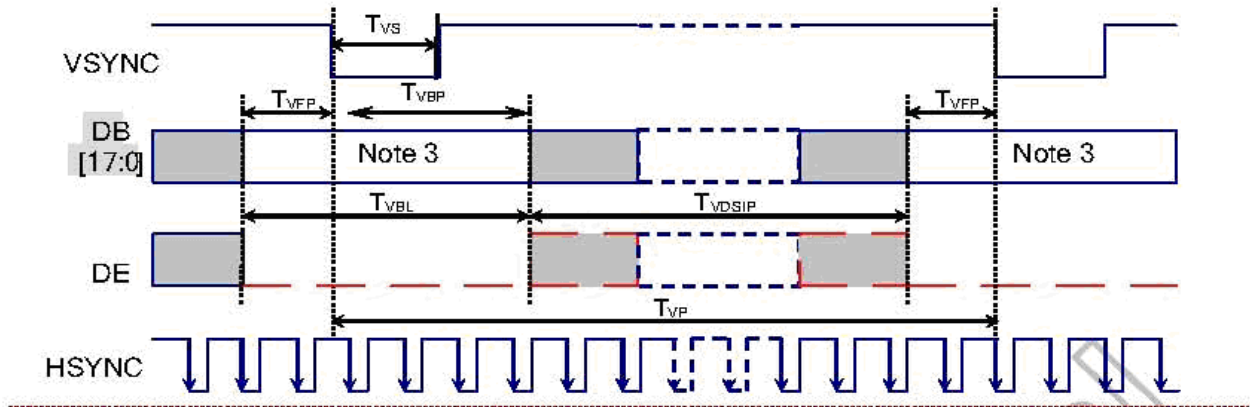
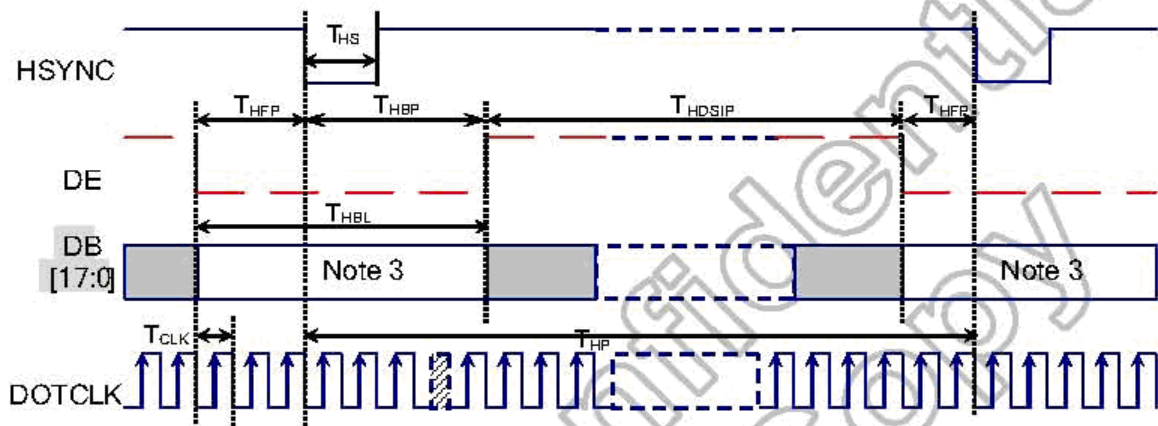
Vertical Timing for RGB I/F

Horizontal Timing for RGB I/F



Characteristics	Symbol	Min	Typ.	Max	Unit
<b>Vertical Timing</b>					
Vertical cycle period	TVP	324	326	452	HS
Vertical low pulse width	TVS	2	2	-	HS
Vertical low pulse width	TVFP	2	2	6	HS
Vertical back porch	TVBP	2	4	126	HS
Vertical blanking period	TVBL	4	6	132	HS
Vertical active area	TVDISP		320		HS
Vertical refresh rate	TVDISP	50	60	80	Hz
<b>Horizontal Timing</b>					
Horizontal cycle period	THP	244	252	1008	DOTCLK
Horizontal low pulse width	THS	2	2	256	DOTCLK
Horizontal front porch	THFP	2	4	256	DOTCLK
Horizontal back porch	THBP	2	8	256	DOTCLK
Horizontal blanking period	THBL	4	12	256	DOTCLK
Horizontal active area	THDISP		240		DOTCLK
Pixel clock cycle TVRR=60Hz	fCLKCYC	3.9		16.6	MHz

**Note:** (1) IOVCC=1.65 to 3.3V, VCI=2.3 to 3.3V, VSSA=VSSD=0V, Ta=-30 to 70 (to +85 no damage)

(2) Data lines can be set to "High" or "Low" during blanking time – Don't care.

(3) HP is multiples of DOTCLK.

### 8.3 Reset Input Timing

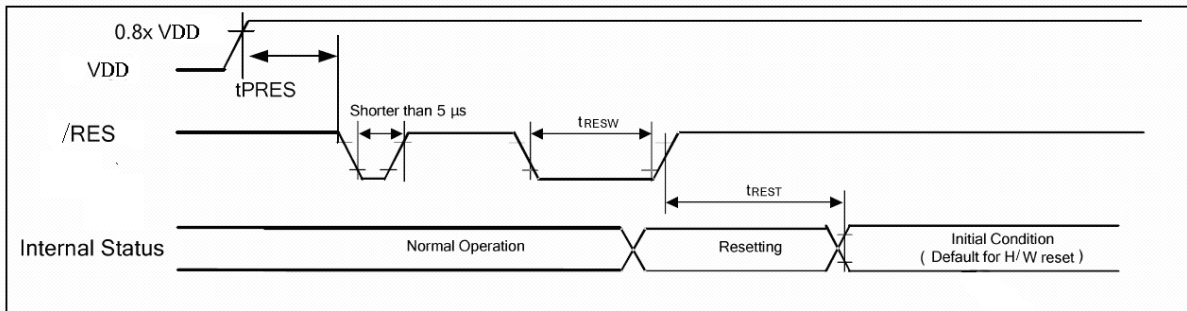

Figure 8.3.1 Reset Input Timing

Symbol	Parameter	Related Pins	Min.	Typ.	Max.	Unit	Note
tRESW	Reset low pulse width(1)	NRESET	10	-	-	μs	
tRESW	Reset complete time(2)		-	-	5	ms	When reset applied during STB mode
			-	-	120	ms	When reset applied during STB mode
tPRES	Reset goes high level after Power on time	NRESET & IOVCC	1	-	-	ms	

**Note:** (1) Spike due to an electrostatic discharge on NRESET line does not cause irregular system reset according to the table below.

NRESET Pulse	Action
Shorter than 5 μ	Reset Rejected
Longer than 10 μs	Reset
Longer than 10 μs	Reset Start

(2) During the resetting period, the display will be blanked (The display is entering blanking sequence,

which maximum time is 120 ms, when Reset Starts in STB Out –mode. The display remains the blank state in STB –mode) and then return to Default condition for H/W reset.

(3) During Reset Complete Time, ID2 and VCOMOF value in OTP will be latched to internal register during this period. This loading is done every time when there is H/W reset complete time (tREST) within 5ms after a rising edge of NRESET.

(4) Spike Rejection also applies during a valid reset pulse as shown below

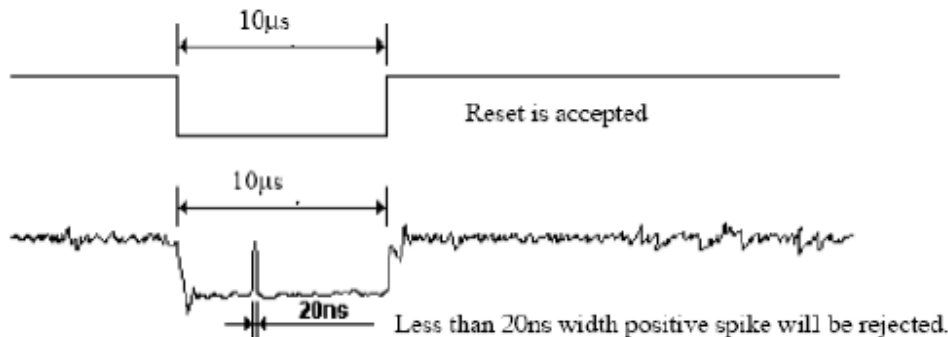

(5) It is necessary to wait 5msec after releasing !RES before sending commands. Also STB Out command cannot be sent for 120msec.

## 9. OPTICAL CHARACTERISTICS

Item	Symbol	Conditions	Specifications			Unit	Note	
			Min.	Typ.	Max.			
Luminance	B	Center $\theta_x=\theta_y=0^\circ$	200	250	--	Cd/m <sup>2</sup>	Note: 4,5	
Uniformity			80	--	--	%	Note: 4,5	
Contrast Ratio	CR	Center $\theta_x=\theta_y=0^\circ$	150	250	--		Note: 1,4	
Response Time	Ton+ Toff		--	30	40	ms	Note: 2	
Chroma ticity	Red		Rx	0.582	0.632	0.682	--	Note: 4
			Ry	0.278	0.328	0.378	--	
	Green	Gx	0.246	0.296	0.346	--		
		Gy	0.526	0.576	0.626	--		
	Blue	Bx	0.083	0.133	0.183	--		
		By	0.072	0.122	0.172	--		
	White	Wx	0.254	0.304	0.354	--		
		Wy	0.284	0.334	0.384	--		
Viewing Angle	Hor.	$\theta_{x+}$	60	70	--	deg.	Note: 3,4	
		$\theta_{x-}$	60	70	--			
	Ver.	$\theta_{y+}$	60	70	--			
		$\theta_{y-}$	40	50	--			

Note (1) Definition of Contrast Ratio (CR):

The contrast ratio can be calculated by the following expression. Contrast Ratio (CR) = L63 / L0

L63: Luminance of gray level 63

L 0: Luminance of gray level 0

CR =CR (5)

CR (X) is corresponding to the Contrast Ratio of the point X at Figure in Note (5).

Note (2) Definition of Response Time (Ton, Toff):

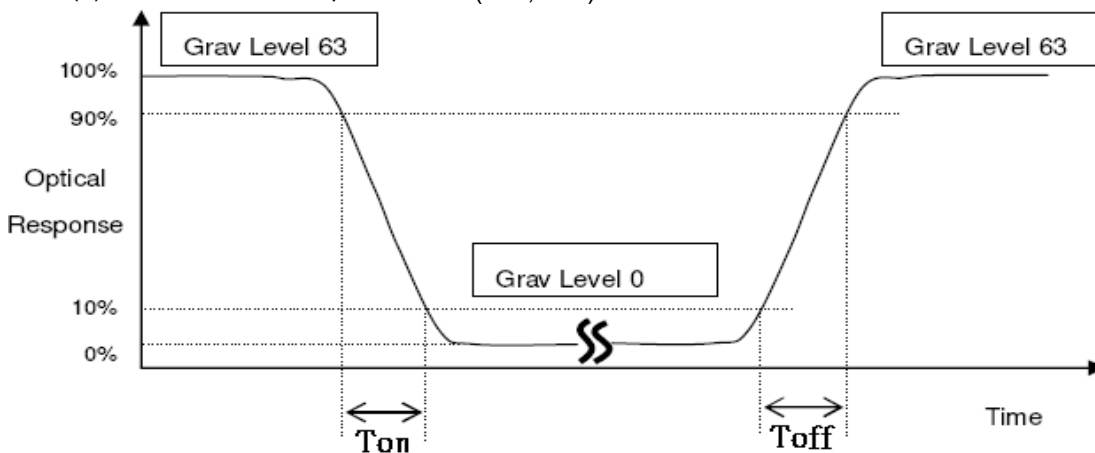

Note (3) Definition of Viewing Angle

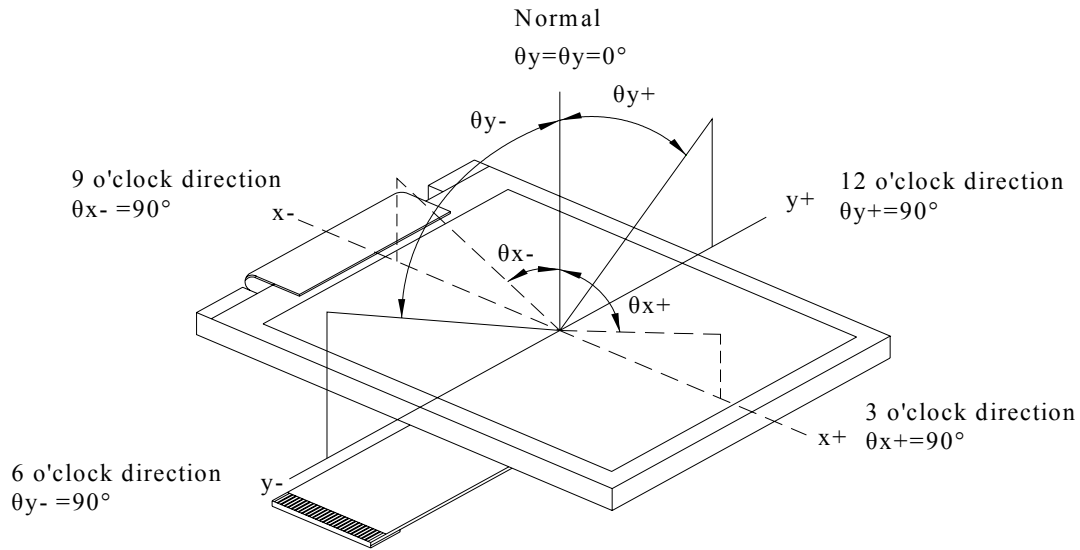

Note (4) The method of optical measurement:

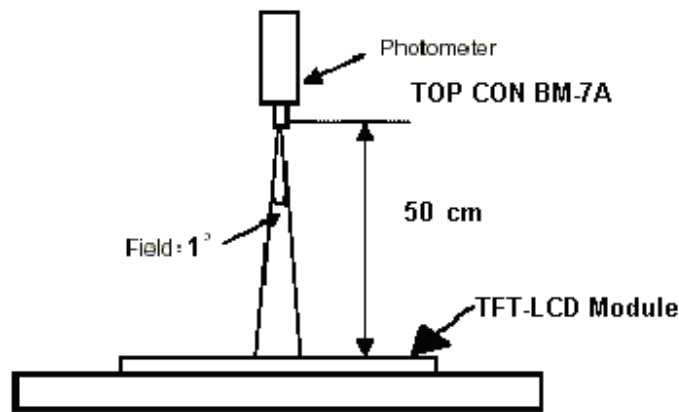

Note (5) Definition of Brightness Uniformity (B-uni):

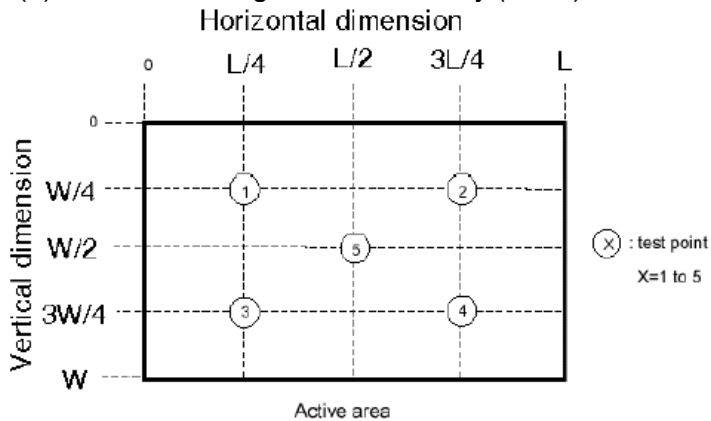

$$B\text{-uni} = \frac{\text{Minimum luminance of 5 points}}{\text{Maximum luminance of 5 points}} \quad (\text{Note 5}).$$

## 10. APPEARANCE SPECIFICATIONS FOR VERIFONE

### 10.1 Inspection condition

#### 10.1.1 Inspection conditions

10.1.1.1 Inspection Distance:  $35 \pm 5$  cm

10.1.1.2 View Angle:

- ( 1 ) Inspection under operating condition :  $\pm 5^\circ$
- ( 2 ) Inspection under non-operating condition :  $\pm 45^\circ$

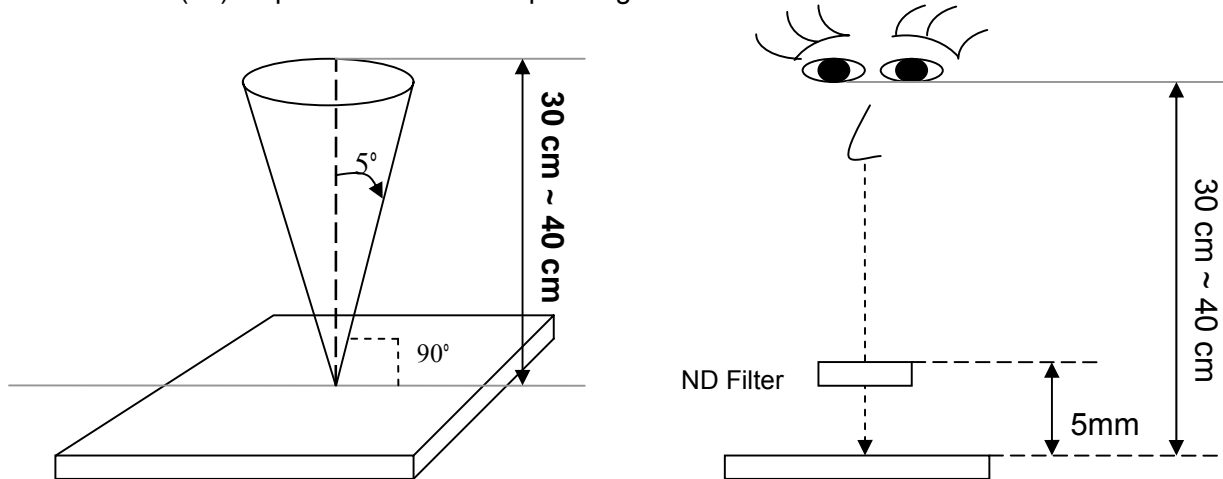

#### 10.1.2 Environment conditions :

Ambient Temperature :		$25 \pm 5$
Ambient Humidity :		$65 \pm 5\%$
Ambient Illumination	Cosmetic Inspection	More than 600lux
	Functional Inspection	300 ~ 800lux

### 10.2 Definition of applicable Zones

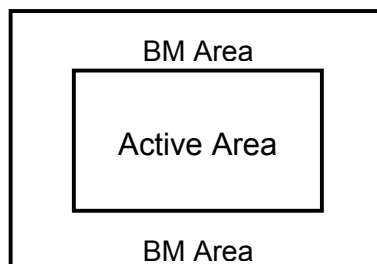

**10.3 Inspection Parameters**

No.	Parameter	Criteria														
1	Operating	Display function: No Display malfunction (Major)														
		Contrast ratio (Black, White): Does not meet specified range in the spec. (Major) (Note:3).														
		Line Defect: No obvious Vertical and Horizontal line defect in bright, dark and colored. (Major) (Note:1)														
		Point Defect (Red, green, blue, dark): Active area $\leq 3$ dotsMinor)(Note:1)														
		<table border="1"> <thead> <tr> <th rowspan="2">Item</th> <th>Acceptable number</th> <th rowspan="2">Total</th> </tr> <tr> <th>Active Area</th> </tr> </thead> <tbody> <tr> <td>Bright</td> <td>1</td> <td rowspan="2">3</td> </tr> <tr> <td>Dark</td> <td>2</td> </tr> </tbody> </table>	Item	Acceptable number	Total	Active Area	Bright	1	3	Dark	2					
		Item		Acceptable number		Total										
Active Area																
Bright	1	3														
Dark	2															
Non-uniformity: Visible through 6%ND filter white, R, G, B																
Foreign material in Black or White spots shape ( $W > 1/4L$ )																
<table border="1"> <thead> <tr> <th>Zone Dimension</th> <th>Acceptable number</th> <th>Dot distance</th> <th>Class Of Defects</th> <th>AQL Level</th> </tr> </thead> <tbody> <tr> <td><math>\leq 0.1</math></td> <td>3</td> <td><math>&gt; 30</math> mm</td> <td rowspan="2">Minor</td> <td rowspan="2">1.5</td> </tr> <tr> <td><math>0.1 \leq \leq 0.2</math></td> <td>2</td> <td><math>&gt; 50</math> mm</td> </tr> </tbody> </table> <p><math>D = (\text{Long} + \text{Short}) / 2</math> * : Disregard</p>	Zone Dimension	Acceptable number	Dot distance	Class Of Defects	AQL Level	$\leq 0.1$	3	$> 30$ mm	Minor	1.5	$0.1 \leq \leq 0.2$	2	$> 50$ mm			
Zone Dimension	Acceptable number	Dot distance	Class Of Defects	AQL Level												
$\leq 0.1$	3	$> 30$ mm	Minor	1.5												
$0.1 \leq \leq 0.2$	2	$> 50$ mm														
Foreign Material in Line or spiral shape ( $W \leq 1/4L$ ) (Note: 4)																
<table border="1"> <thead> <tr> <th>L (mm) \ Zone W(mm)</th> <th>Acceptable number</th> <th>Dot distance</th> <th>AQL Level</th> </tr> </thead> <tbody> <tr> <td><math>L \leq 5</math>    <math>W \leq 0.2</math></td> <td>2</td> <td rowspan="3"><math>&gt; 10</math> mm</td> <td rowspan="3">1.5</td> </tr> <tr> <td><math>L \leq 3</math>    <math>0.02 &lt; W \leq 0.05</math></td> <td>2</td> </tr> <tr> <td><math>L \leq 2</math>    <math>0.05 \leq W \leq 0.08</math></td> <td>1</td> </tr> <tr> <td>---</td> <td><math>W &gt; 0.08</math></td> <td>0</td> <td></td> </tr> </tbody> </table> <p>L : Length    W : Width    * : Disregard</p>	L (mm) \ Zone W(mm)	Acceptable number	Dot distance	AQL Level	$L \leq 5$ $W \leq 0.2$	2	$> 10$ mm	1.5	$L \leq 3$ $0.02 < W \leq 0.05$	2	$L \leq 2$ $0.05 \leq W \leq 0.08$	1	---	$W > 0.08$	0	
L (mm) \ Zone W(mm)	Acceptable number	Dot distance	AQL Level													
$L \leq 5$ $W \leq 0.2$	2	$> 10$ mm	1.5													
$L \leq 3$ $0.02 < W \leq 0.05$	2															
$L \leq 2$ $0.05 \leq W \leq 0.08$	1															
---	$W > 0.08$	0														
2	External Inspection (non-operating)	Dimension: Outline (Major)														
		Bezel appearance: uneven (Minor)														
		Scratch on the polarizer: (Note:2)														
		<table border="1"> <thead> <tr> <th>L (mm) \ Zone W(mm)</th> <th>Acceptable number</th> <th>Class Of Defects</th> <th>AQL Level</th> </tr> </thead> <tbody> <tr> <td><math>L \leq 1.5</math>    <math>W &gt; 0.1</math></td> <td>0</td> <td rowspan="2">Minor</td> <td rowspan="2">1.5</td> </tr> <tr> <td><math>L \leq 2</math>    <math>W \leq 0.1</math></td> <td>3</td> </tr> </tbody> </table> <p>L : Length    W : Width    * : Disregard</p>	L (mm) \ Zone W(mm)	Acceptable number	Class Of Defects	AQL Level	$L \leq 1.5$ $W > 0.1$	0	Minor	1.5	$L \leq 2$ $W \leq 0.1$	3				
		L (mm) \ Zone W(mm)	Acceptable number	Class Of Defects	AQL Level											
$L \leq 1.5$ $W > 0.1$	0	Minor	1.5													
$L \leq 2$ $W \leq 0.1$	3															
Dent and spots shape on the polarize (Note:2):																
<table border="1"> <thead> <tr> <th>Zone Dimension</th> <th>Acceptable number</th> <th>Class Of Defects</th> <th>AQL Level</th> </tr> </thead> <tbody> <tr> <td><math>D \leq 0.3</math></td> <td>3</td> <td rowspan="3">Minor</td> <td rowspan="3">1.5</td> </tr> <tr> <td><math>0.3 &lt; D \leq 0.7</math></td> <td>1</td> </tr> <tr> <td><math>D &gt; 0.7</math></td> <td>0</td> </tr> </tbody> </table> <p><math>D = (\text{Long} + \text{Short}) / 2</math> * : Disregard</p>	Zone Dimension	Acceptable number	Class Of Defects	AQL Level	$D \leq 0.3$	3	Minor	1.5	$0.3 < D \leq 0.7$	1	$D > 0.7$	0				
Zone Dimension	Acceptable number	Class Of Defects	AQL Level													
$D \leq 0.3$	3	Minor	1.5													
$0.3 < D \leq 0.7$	1															
$D > 0.7$	0															

Class of defects			Definition
	<b>Major</b>	AQL 0.65	
<b>Minor</b>	AQL 1.5		It is a defect that will not result in functioning problem with deviation classified.

Note:1.(a)Bright point defect is defined as point defect of R,G,B with area >1/2 pixel respectively

(b)Dark point defect is defined as visible in full white pattern.

(c)Definition of distribution of point defect is as follows:

- minimum separation between dark point defects should be larger than 5mm.
- minimum separation between bright point defects should be larger than 5mm.

(d)Definition of joined bright point defect and joined dark point defect are as follows:

- Two or more joined bright point defects must be nil.
- Three joined dark point defects must be nil.
- Coupling of one dark and one bright point in junction is counted as one dark and bright spot with 1 pair maximum.
- Two Joined dark point is counted as two dark point with 2 pair maximum.

(e) Lin defect is defined as visible by using 10% ND filter.

Note:2 The external inspection should be conducted at the distance  $30 \pm 5$ cm between the eyes of inspector and the panel .

Note:3 Luminance measurement for contrast ratio is at the distance  $50 \pm 5$ cm between the detective head and the panel with ambient illuminance less than 1 lux. Contrast ratio is obtained at optimum view angle.

Note:4 W-Width in mm , L-length of Max.(L1,L2) in mm.

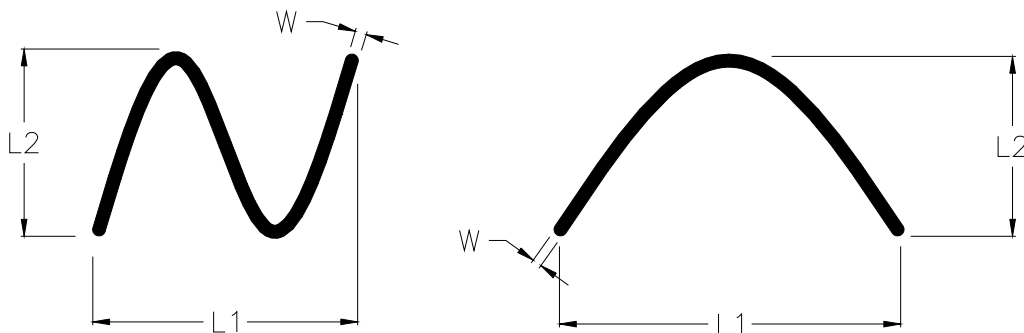

#### 10.4 Sampling Condition

Unless otherwise agree in written, the sampling inspection shall be applied to the incoming inspection of customer.

Lot size: Quantity of shipment lot per model.

Sampling type: normal inspection, single sampling

Sampling table: MIL-STD-105E

Inspection level: Level II

## 11. QUALITY ASSURANCE

### Test Condition

#### 11.1.1 Temperature and Humidity(Ambient Temperature)

Temperature :  $20 \pm 5^{\circ}\text{C}$   
 Humidity :  $65 \pm 5\%$

#### 11.1.2 Operation

Unless specified otherwise, test will be conducted under function state.

#### 11.1.3 Container

Unless specified otherwise, vibration test will be conducted to the product itself without putting it in a container.

#### 11.1.4 Test Frequency

In case of related to deterioration such as shock test. It will be conducted only once.

#### 11.1.5 Test Method

No.	Reliability Test Item & Level	Test Level	Remark
1	High Temperature Storage Test	Ta=80°C,240hrs	IEC68-2-2
2	Low Temperature Storage Test	Ta =-30°C,240hrs	IEC68-2-1
3	High Temperature Operation Test	Ta =70°C,240hrs	IEC68-2-2
4	Low Temperature Operation Test	Ta =-20°C,240hrs	IEC68-2-1
5	High Temperature and High Humidity Operation Test	Ta =60°C,90% RH,240hrs	IEC68-2-3
6	Temperature Cycle Test (No operation)	-30°C → +25°C → +80°C,200 Cycles 30 min 5min 50 min	IEC68-2-14
7	Vibration Test (No operation)	Frequency:10 ~ 55 Hz Amplitude:1.5 mm Sweep Time:11min Test Period:6 Cycles for each Direction of X,Y,Z	IEC68-2-6
8	Drop test	Height:60cm 1 conner,3edges,6surfaces	IEC68-2-32
9	Shock Test (No operation)	100G, 6ms Direction : ± X± Y± Z Cycle : 3 times	IEC68-2-27
10	Electrostatic Discharge Test (No operation)	State: operating Standard: IEC 61000-4-2 Location: LCM/TP surface Condition:150pf 330Ω Contact +/- 6kV Air +/-8kV Criteria: Class C	IEC-61000-4-2



## 12. LCM PRODUCT LABEL DEFINE

Product Label style:

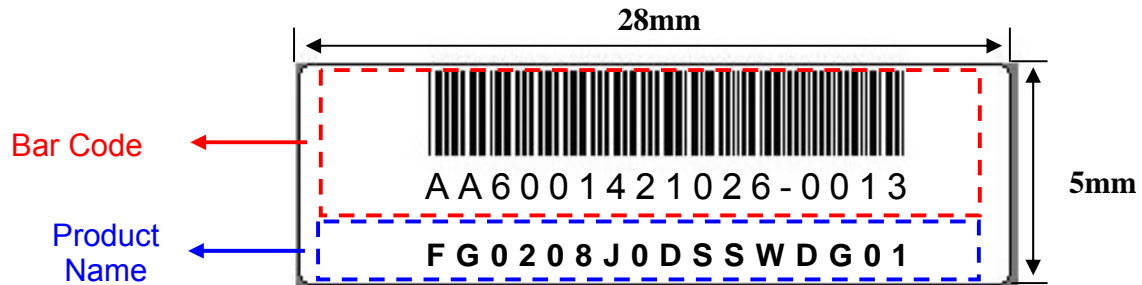

Work order Define:

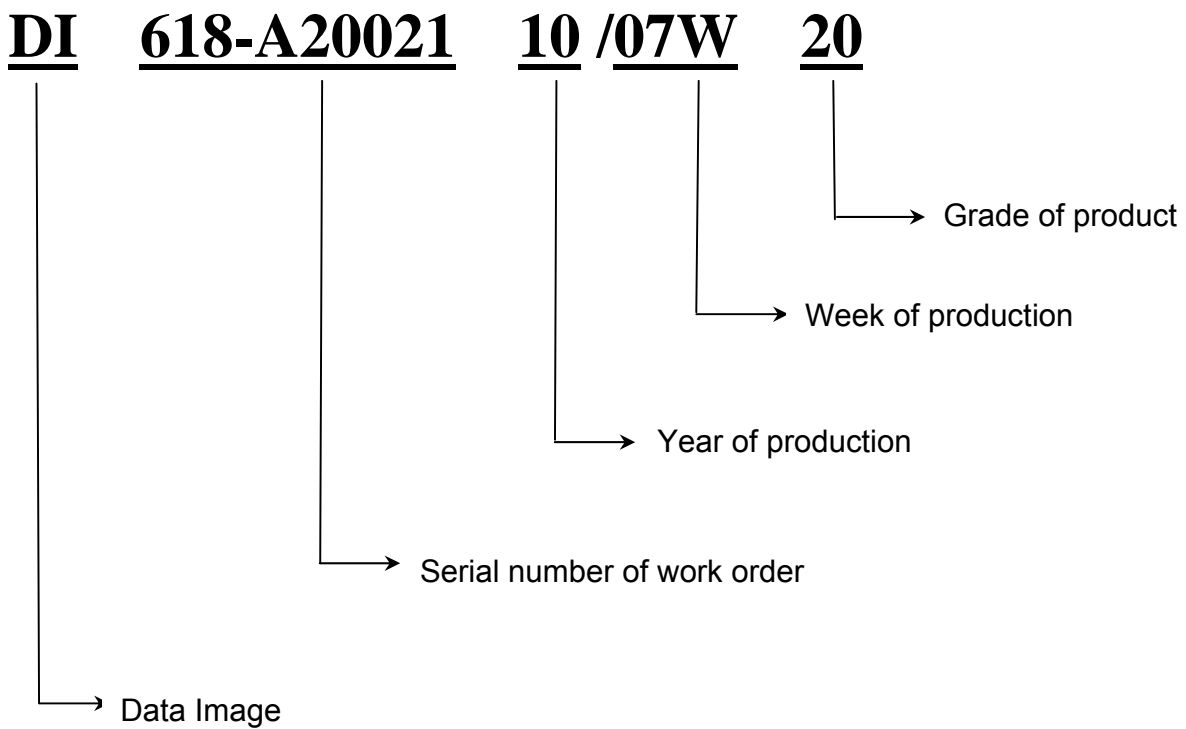

**Product Name Define:**

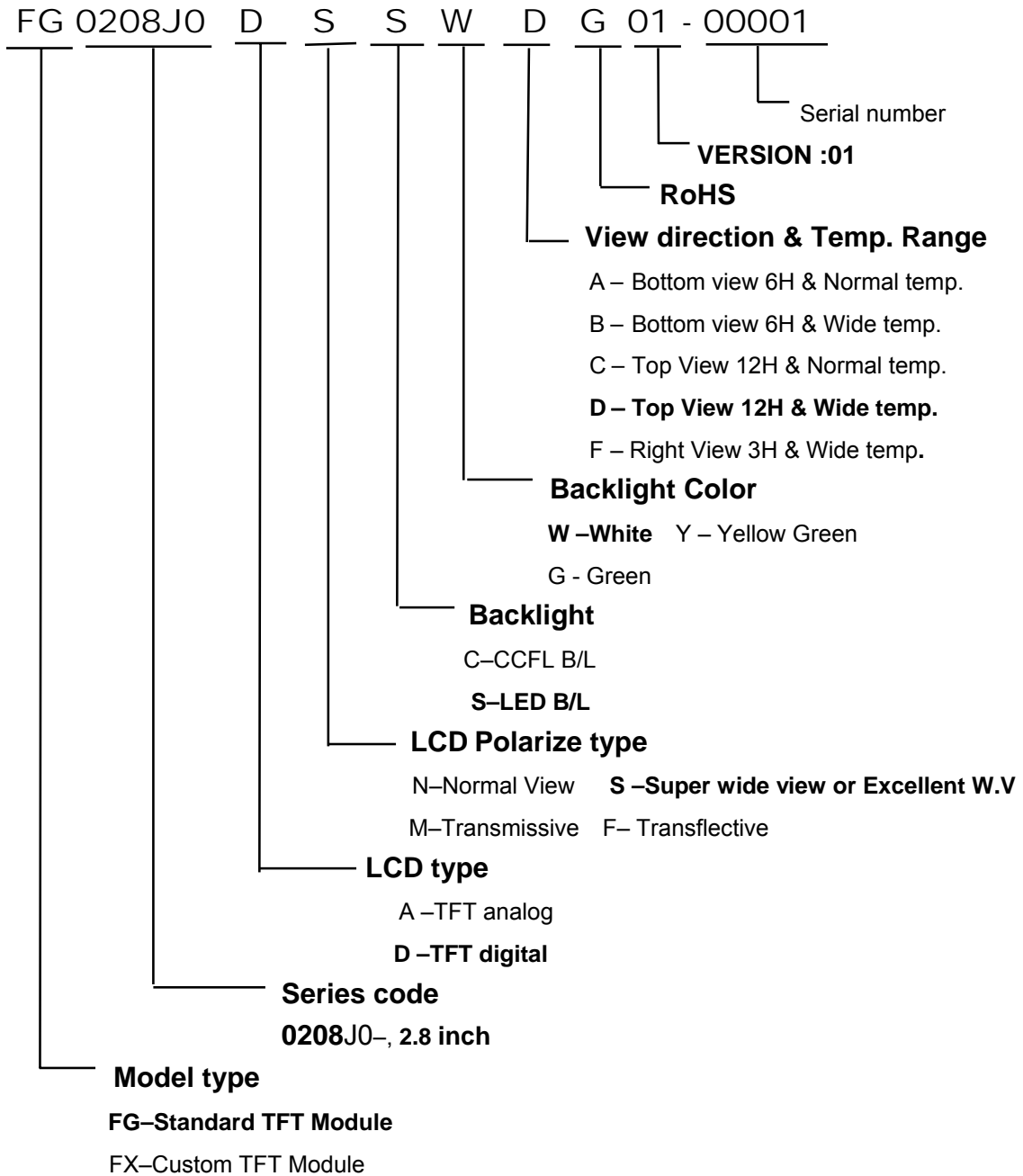

### 13. PRECAUTIONS IN USE LCM

1. ASSEMBLY PRECAUTIONS
  - (1) You must mount a module using holes arranged in four corners or four sides.
  - (2) You should consider the mounting structure so that uneven force (ex. Twisted stress) is not applied to the module. And the case on which a module is mounted should have sufficient strength so that external force is not transmitted directly to the module.
  - (3) Do not touch, push or rub the exposed polarizers with glass, tweezers or anything harder than HB pencil lead. And please do not rub with dust clothes with chemical treatment.
  - (4) Wipe off saliva or water drops as soon as possible. Their long time contact with polarizer causes deformations and color fading.
  - (5) Do not open the case because inside circuits do not have sufficient strength.
  - (6) Please do not take a LCD module to pieces and reconstruct it. Resolving and reconstructing modules may cause them not to work well.
  - (7) Please do not touch metal frames with bare hands and soiled gloves. A color change of the metal frames can happen during a long preservation of soiled LCD modules.
  - (8) Please pay attention to handling lead wire of backlight so that it is not tugged in connecting with inverter.
2. OPERATING PRECAUTIONS
  - (1) Please be sure to turn off the power supply before connecting and disconnecting signal input cable.
  - (2) Please do not change variable resistance settings in LCD module. They are adjusted to the most suitable value. If they are changed, it might happen LCD does not satisfy the characteristics specification
  - (3) Be careful for condensation at sudden temperature change. Condensation makes damage to polarizer or electrical contacted parts. And after fading condensation, smear or spot will occur.
  - (4) When fixed patterns are displayed for a long time, remnant image is likely to occur.
  - (5) Module has high frequency circuits. Sufficient suppression to the electromagnetic interference shall be done by system manufacturers. Grounding and shielding methods may be important to minimize the interference.
  - (6) Please consider that LCD backlight takes longer time to become stable of radiation characteristics in low temperature than in room temperature.
3. ELECTROSTATIC DISCHARGE CONTROL
  - (1) The operator should be grounded whenever he/she comes into contact with the module. Never touch any of the conductive parts such the copper leads on the PCB and the interface terminals with any parts of the human body.
  - (2) The modules should be kept in antistatic bags or other containers resistant to static for storage.
  - (3) Only properly grounded soldering irons should be used.
  - (4) If an electric screwdriver is used, it should be well grounded and shielded from commutator sparks.
  - (5) The normal static prevention measures should be observed for work clothes and working benches; for the latter conductive (rubber) mat is recommended
  - (6) Since dry air is inductive to statics, a relative humidity of 50-60% is recommended.
4. STORAGE PRECAUTIONS
  - (1) When you store LCDs for a long time, it is recommended to keep the temperature between 0°C-40°C without the exposure of sunlight and to keep the humidity less than 90%RH.
  - (2) Please do not leave the LCDs in the environment of high humidity and high temperature such as 60°C 90%RH
  - (3) Please do not leave the LCDs in the environment of low temperature; below -20°C.
5. OTHERS
  - (1) A strong incident light into LCD panel might cause display characteristics' changing inferior because of polarizer film, color filter, and other materials becoming inferior. Please do not expose LCD module direct sunlight Land strong UV rays
  - (2) Please pay attention to a panel side of LCD module not to contact with other materials in preserving it alone.
  - (3) For the packaging box, please pay attention to the followings:
  - (4) Please do not pile them up more than 5 boxes. (They are not designed so.) And please do not turn over.
  - (5) Please handle packaging box with care not to give them sudden shock and vibrations. And also please do not throw them up.
  - (6) Packing box and inner case for LCDs are made of cardboard. So please pay attention not to get them wet. (Such like keeping them in high humidity or wet place can occur getting them wet.)
6. LIMITED WARRANTY

Unless otherwise agreed between DATA IMAGE and customer, DATA IMAGE will replace or repair any of its LCD and LCM which is found to be defective electrically and visually when inspected in accordance with DATA IMAGE acceptance standards, for a period on one year from date of shipment. Confirmation of such date shall be based on freight documents. The warranty liability of DATA IMAGE is limited to repair and/or replacement on the terms set forth above. DATA IMAGE will not responsible for any subsequent or consequential events.

# 14. OUTLINE DRAWING

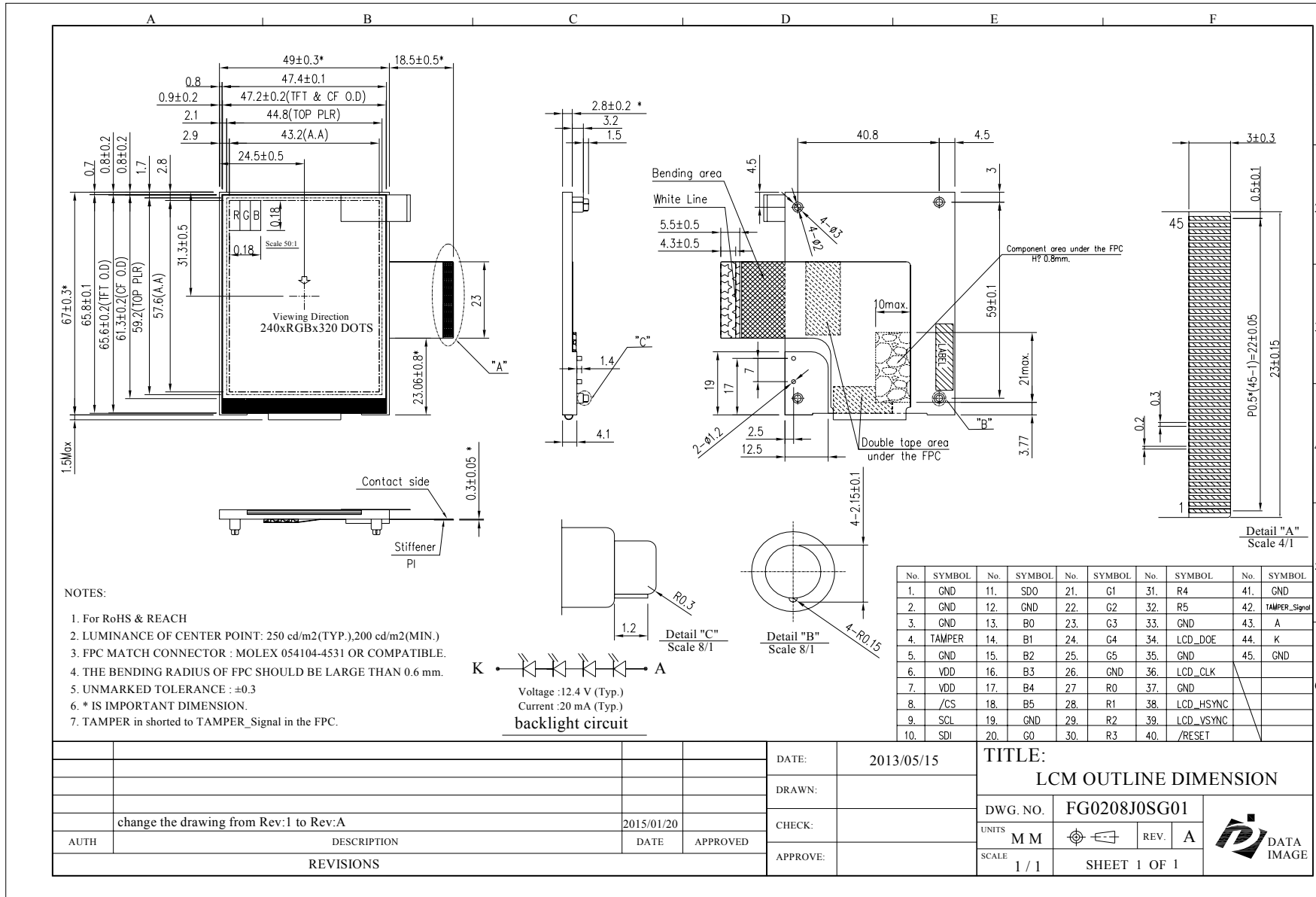

**NOTES:**

1. For RoHS & REACH
2. LUMINANCE OF CENTER POINT: 250 cd/m2(TYP.),200 cd/m2(MIN.)
3. FPC MATCH CONNECTOR : MOLEX 054104-4531 OR COMPATIBLE.
4. THE BENDING RADIUS OF FPC SHOULD BE LARGE THAN 0.6 mm.
5. UNMARKED TOLERANCE : ±0.3
6. \* IS IMPORTANT DIMENSION.
7. TAMPER in shorted to TAMPER\_Signal in the FPC.

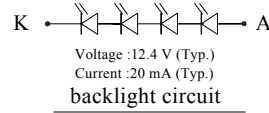

No.	SYMBOL	No.	SYMBOL	No.	SYMBOL	No.	SYMBOL	No.	SYMBOL
1.	GND	11.	SDO	21.	G1	31.	R4	41.	GND
2.	GND	12.	GND	22.	G2	32.	R5	42.	TAMPER_Signal
3.	GND	13.	B0	23.	G3	33.	GND	43.	A
4.	TAMPER	14.	B1	24.	G4	34.	LCD_DOE	44.	K
5.	GND	15.	B2	25.	G5	35.	GND	45.	GND
6.	VDD	16.	B3	26.	GND	36.	LCD_CLK		
7.	VDD	17.	B4	27.	R0	37.	GND		
8.	/CS	18.	B5	28.	R1	38.	LCD_HSYNC		
9.	SCL	19.	GND	29.	R2	39.	LCD_VSYNC		
10.	SDI	20.	G0	30.	R3	40.	/RESET		

				DATE:	2013/05/15	TITLE:		LCM OUTLINE DIMENSION	
				DRAWN:		DWG. NO.	FG0208J0SG01		
change the drawing from Rev:1 to Rev:A				2015/01/20	CHECK:	UNITS	M M	REV.	A
AUTH	DESCRIPTION			DATE	APPROVED	SCALE	1 / 1	SHEET 1 OF 1	
REVISIONS									

## 15. PACKAGE INFORMATION

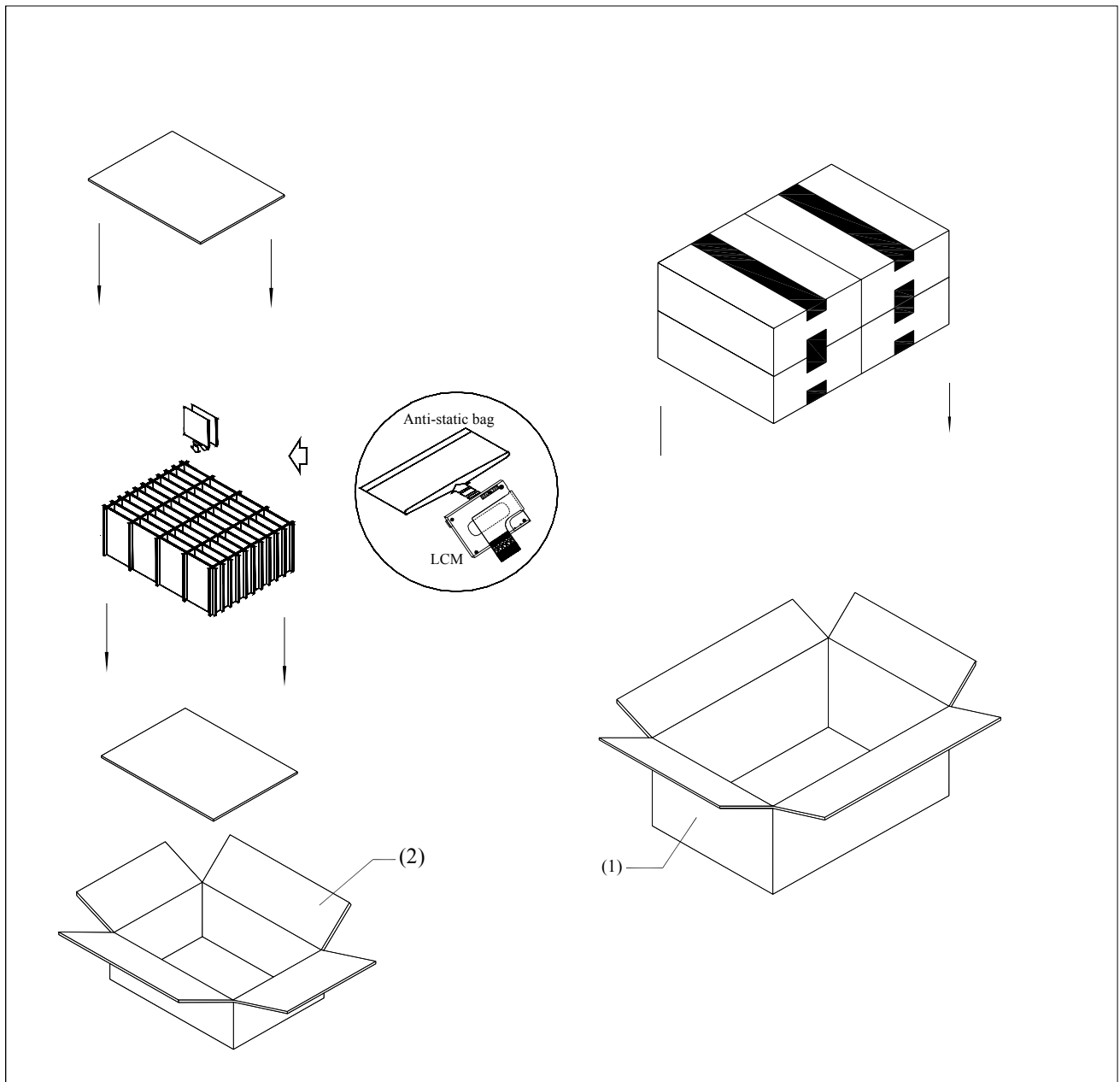

Item	Size(L*W*H)	Quantity	Note
1.Master Carton	482*282*279	1	
2.Inner Carton	267*224*115	4	
Quantity Per Inner Carton	120	Quantity Per Master Carton	480
N . W	7.7 (kg)	G . W	8.7 (kg)