

# EMX-965GME

Intel® GME965 socket 479P Core Duo / Core Solo/Core 2  
Duo Mini ITX Main Board

## User's Manual



Ver. 1.00

# Contents

<b>Safety Information</b> .....	<b>4</b>
<b>Technical Support</b> .....	<b>5</b>
<b>Conventions Used in This Guide</b> .....	<b>5</b>
<b>Packing List</b> .....	<b>6</b>
<b>Revision History</b> .....	<b>7</b>
<b>Specifications Summary</b> .....	<b>8</b>
<b>Block Diagram</b> .....	<b>10</b>
<b>Production Introduction</b> .....	<b>12</b>
1.1 Before you Proceed .....	12
1.2 Motherboard Overview.....	13
1.2.1 Placement Direction .....	13
1.2.2 Screw Holes .....	13
1.3 Motherboard Layout.....	14
1.3.1 Layout Content List .....	15
1.4 Central Processing Unit (CPU).....	17
1.4.1 Installing the CPU.....	18
1.4.2 Installing the CPU Heatsink and Fan .....	20
1.4.3 Uninstalling the CPU Heatsink and Fan.....	22
1.5 System Memory .....	23
1.5.1 DIMM Sockets Location .....	23
1.5.2 Memory Configurations .....	24
1.5.3 Installing a DDR2 DIMM.....	25
1.5.4 Removing a DDR2 DIMM.....	26
1.6 Expansion Slots .....	27
1.6.1 Installing an Expansion Card .....	27
1.6.2 Configuring an Expansion Card .....	27
1.6.3 Standard Interrupt Assignments.....	28
1.6.4 PCI Slots .....	28
1.7 Jumpers .....	29
1.7.1 Clear CMOS (CCMOS1).....	29
1.7.2 COM1 RI/+5V/+12V Selection (JCOMPWR1, JCOMPWR2).....	30
1.7.3 COM2 RI/+5V/+12V Selection (JCOMPWR1, JCOMPWR2).....	30
1.7.4 COM3 RI/+5V/+12V Selection (JCOMPWR3, JCOMPWR4).....	31
1.7.5 COM4 RI/+5V/+12V Selection (JCOMPWR3, JCOMPWR4).....	31
1.7.6 SM Power Connector (SM_PWRBTN1).....	32

# Contents

<b>1.8</b>	<b>Connectors</b> .....	<b>33</b>
1.8.1	Rear Panel Connectors.....	33
1.8.2	Amplifier Connector (AMPJ1).....	35
1.8.3	ATX Power Connector (ATXPWR1).....	35
1.8.4	Serial Port 3 Connector (COM3).....	36
1.8.5	Serial Port 4 Connector (COM4).....	36
1.8.6	CPU Fan Connector (CPU_FAN1).....	37
1.8.7	Power Fan Connector (PWR_FAN1).....	37
1.8.8	System Panel Connector (FPIO1).....	38
1.8.9	Primary IDE Connector (IDE1).....	39
1.8.10	LVDS Connector (JLVDS1).....	39
1.8.11	LCD Inverter Connector (JBKL1).....	40
1.8.12	Digital I/O Connector (JDIO1).....	40
1.8.13	SPI Connector (JSPI1).....	41
1.8.14	Digital Audio Connector (SPDIF_OUT2).....	41
1.8.15	Serial SATA Connector [Black] (SATA1, SATA2, SATA3).....	42
1.8.16	USB 2.0 Connector (USB3, USB4, USB5).....	43

## Safety Information

### Electrical safety

- To prevent electrical shock hazard, disconnect the power cable from the electrical outlet before relocating the system.
- When adding or removing devices to or from the system, ensure that the power cables for the devices are unplugged before the signal cables are connected. If possible, disconnect all power cables from the existing system before you add a device.
- Before connecting or removing signal cables from the motherboard, ensure that all power cables are unplugged.
- Seek professional assistance before using an adapter or extension cord. These devices could interrupt the grounding circuit.
- Make sure that your power supply is set to the correct voltage in your area. If you are not sure about the voltage of the electrical outlet you are using, contact your local power company.
- If the power supply is broken, do not try to fix it by yourself. Contact a qualified service technician or your retailer.

### Operation safety

- Before installing the motherboard and adding devices on it, carefully read all the manuals that came with the package.
- Before using the product, make sure all cables are correctly connected and the power cables are not damaged. If you detect any damage, contact your dealer immediately.
- To avoid short circuits, keep paper clips, screws, and staples away from connectors, slots, sockets and circuitry.
- Avoid dust, humidity, and temperature extremes. Do not place the product in any area where it may become wet.
- Place the product on a stable surface.
- If you encounter technical problems with the product, contact a qualified service technician or your retailer.



---

The symbol of the crossed out wheeled bin indicates that the product (electrical and electronic equipment) should not be placed in municipal waste. Check local regulations for disposal of electronic products.

---

## Technical Support

If a problem arises with your system and no solution can be obtained from the user's manual, please contact your place of purchase or local distributor. Alternatively, please try the following help resources for further guidance. Visit the Avalue website for FAQ, technical guide, BIOS updates, driver updates, and other information:

<http://www.avalue.com.tw>

## Conventions Used in This Guide

To make sure that you perform certain tasks properly, take note of the following symbols used throughout this manual.



**DANGER/WARNING:** Information to prevent injury to yourself when trying to complete a task.



**CAUTION:** Information to prevent damage to the components when trying to complete a task.



**IMPORTANT:** Instructions that you **MUST** follow to complete a task.



**NOTE:** Tips and additional information to help you complete a task.

## Packing List

Before you begin installing your single board, please make sure that the following materials have been shipped:

- ✓ 1 x Intel GME965 Mini ITX Main board
- ✓ 1 x CD-ROM contains the followings:
  - User's manual (this manual in PDF file)
  - Drivers
- ✓ 2 x COM1 cable (9-pin w/o bracket, 26cm)
- ✓ 1 x IDE HDD cable (40-pin, 30cm)
- ✓ 3 x SATA cable kit
- ✓ 1 x I/O Shield
- ✓ 6 x 4# Screws
- ✓ 1 x Startup Manual



---

If any of the above items is damaged or missing, please contact your retailer.

---

## Revision History

Revision	Revision History	Date
V 1.0	First release for PCB 1.00	October 02, 2007

## Specifications Summary

<b>Features</b>	1	Supports Intel socket P Core 2 Duo / Core Duo / Core 2 Solo / Core Solo mobil CPU with 65nm process technology
	2	Intel GME965 Chipset
	3	Two 200-pin SODIMMs sockets up to 4GB Dual Channel DDR2 533/667 SDRAM
	4	Intel Graphics Media Accelerator X3100
	5	DVI, Dual 18/24-bit LVDS
	6	Realtek ALC888 5.1+2 CH Audio (5W x 2-CH Amplified ) with Dual Independent Audio Streams
	7	Dual Gigabit Lan Realtek RTL8111B (DVT)
	8	Gigabit LAN Realtek RTL8111B
	9	One PCI slot
	10	4 COM,10 USB 2.0, 3 SATA TPM INFINEON SLB9635TT Module Onboard
<b>System</b>		
<b>CPU</b>	Supports Intel socket P Core 2 Duo / Core Duo / Core 2 Solo / Core Solo mobile CPU with 65nm process technology	
<b>FSB</b>	533/800 MHz	
<b>BIOS</b>	AMI 16 Mb SPI BIOS	
<b>System Chipset</b>	Intel GME965/ICH8M	
<b>I/O Chipset</b>	Winbond W83627DHG-A	
<b>Memory</b>	Two 200-pin SODIMM sockets support up to 4 GB Dual Channel DDR2 533/667 SDRAM	
<b>SSD</b>	One CompactFlash Type I/II socket	
<b>Watchdog Timer</b>	Reset: 1 sec.~255 min. and 1 sec. or 1 min./step	
<b>H/W Status Monitor</b>	Monitoring CPU temperature, voltage, and cooling fan status. Auto throttling control when CPU overheats	
<b>Expansion Slots</b>	One PCI slot (PCI Rev. 2.2 compliant) supports 3 PCI master	
<b>S3</b>	S3 Support	
<b>Smart Fan Control</b>	Yes	
<b>I/O</b>		
<b>MIO</b>	1x EIDE, 3 x SATA, 10 x USB, 4 x RS232, 1 x K/B, 1 x Mouse, (COM1~4 with Power output)	
<b>USB</b>	10 x USB 2.0	
<b>DIO</b>	8-bit General Purpose I/O for DI and DO	



## Specifications Summary

I/O	
<b>Internal I/O</b>	3 x USB connectors support additional 6 USB ports 1 x 20-pin ATX Power connector, 1 x IDE 40-pin connector for two devices 2 x COM port header, 3 x SATA connectors, 1 x Front panel audio connector 1 x Audio amplifier connector, 1 x System panel connector 1 x LVDS connector, 1 x Inverter Power connector, 1 x CPU Fan connector 1 x System Fan connector, 1 x Digital IO header 1 x SPDIF Out connector reserved
<b>Back Panel</b>	1 x PS/2 Keyboard, 1 x PS/2 Mouse, 2 x RS-232, 1 x VGA port, 1 x DVI port 4 x USB 2.0/1.1, 1 x LAN RJ45 Port (one existed, another option) 5.1 + 2 CH Audio I/O (3 jacks)
Display	
<b>Chipset</b>	Intel Graphics Media Accelerator X3100
<b>Display Memory</b>	Intel DVMT 4.0 supports 384 MB video memory
<b>Resolution</b>	2048 x 1536 @ 32 bpp(@ 60Hz)
<b>Dual Display</b>	CRT + LVDS, or CRT + DVI-D
<b>LVDS</b>	Dual-channel 24-bit LVDS
<b>DVI</b>	Chrontel CH7307C DVI transmitter up to 165M pixels/second
Audio	
<b>Audio Codec</b>	Realtek ALC888 Audio Code 5.1+2 ch. with two independent audio stream
<b>Audio Interface</b>	Mic in, Line in, Line out
<b>Audio Amplifier</b>	TPA3005D2 Stereo 5Watt per channel
Ethernet	
<b>LAN1</b>	Realtek RTL8111B PCI-E Gigabit Ethernet Controller
<b>LAN2</b>	Realtek RTL8111B PCI-E Gigabit Ethernet Controller (optional)
Mechanical & Environmental	
<b>Power Type</b>	ATX
<b>Operating Temperature</b>	0~60°C (32~140°F)
<b>Operating Humidity</b>	0%~90% relative humidity, non-condensing
<b>Size (L x W)</b>	6.69" x 6.69" (170 mm x 170 mm)
<b>Weight</b>	0.88 lbs (0.4 Kg)

\* Specifications are subject to change without notice.

# Block Diagram

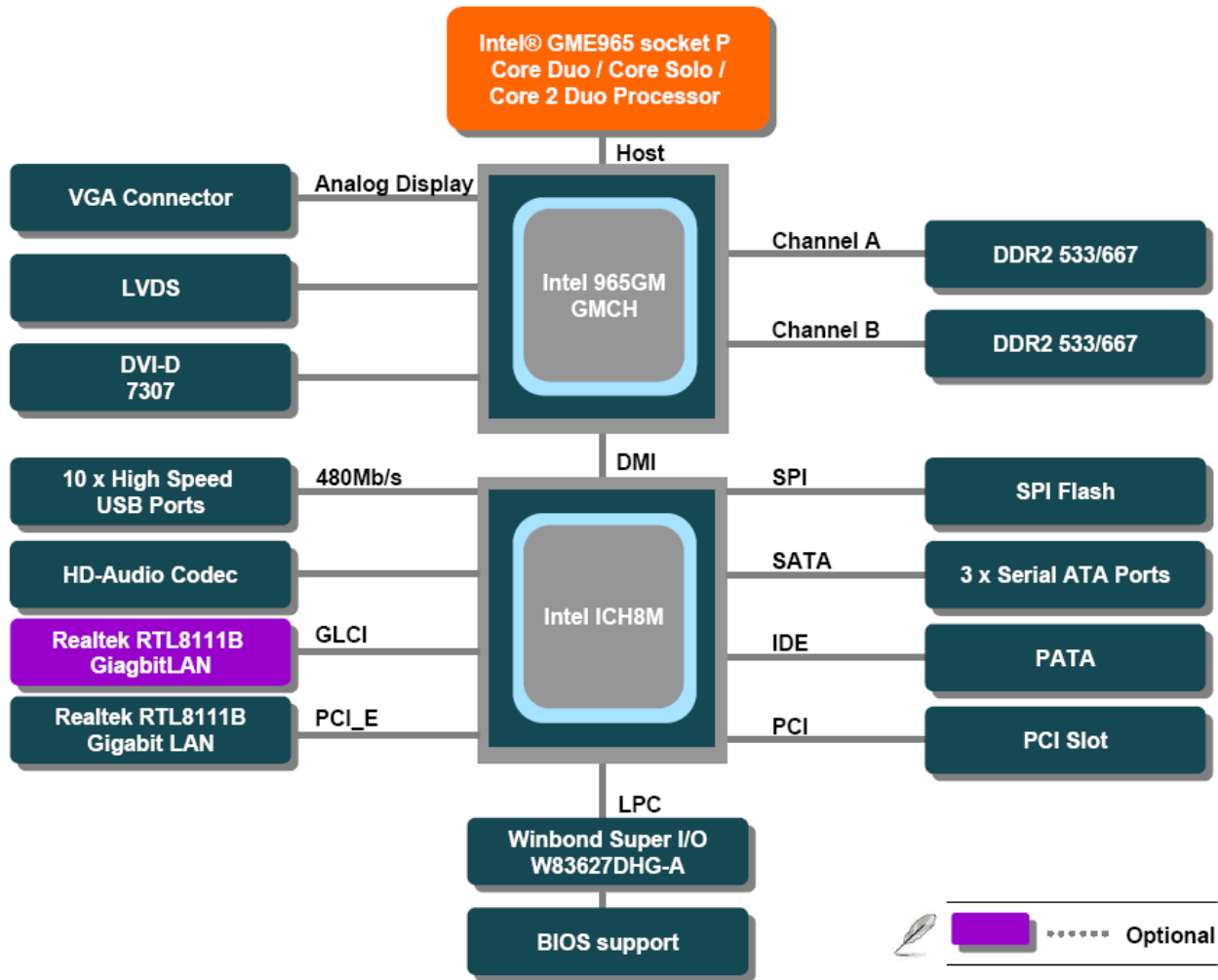

This chapter describes the main board features and the new technologies it supports.

# 1 Product introduction

# Production Introduction

## 1.1 Before you Proceed

Take note of the following precautions before you install motherboard components or change any motherboard settings.



- 
- Unplug the power cord from the wall socket before touching any component.
  - Use a grounded wrist strap or touch a safely grounded object or a metal object, such as the power supply case, before handling components to avoid damaging them due to static electricity
  - Hold components by the edges to avoid touching the ICs on them.
  - Whenever you uninstall any component, place it on a grounded antistatic pad or in the bag that came with the component.
  - Before you install or remove any component, ensure that the ATX power supply is switched off or the power cord is detached from the power supply. Failure to do so may cause severe damage to the motherboard, peripherals, and/or components.
-

## 1.2 Motherboard Overview

Before you install the motherboard, study the configuration of your chassis to ensure that the motherboard fits into it. Refer to the chassis documentation before installing the motherboard.



---

Make sure to unplug the power cord before installing or removing the motherboard. Failure to do so can cause you physical injury and damage motherboard components.

---

### 1.2.1 Placement Direction

When installing the motherboard, make sure that you place it into the chassis in the correct orientation. The edge with external ports goes to the rear part of the chassis as indicated in the image below.

### 1.2.2 Screw Holes

Place four (4) screws into the holes indicated by circles to secure the motherboard to the chassis.



---

Do not over tighten the screws! Doing so can damage the motherboard.

---

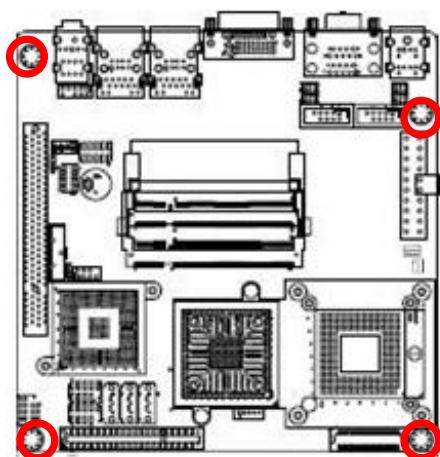

Place this side towards the rear of the chassis

### 1.3 Motherboard Layout

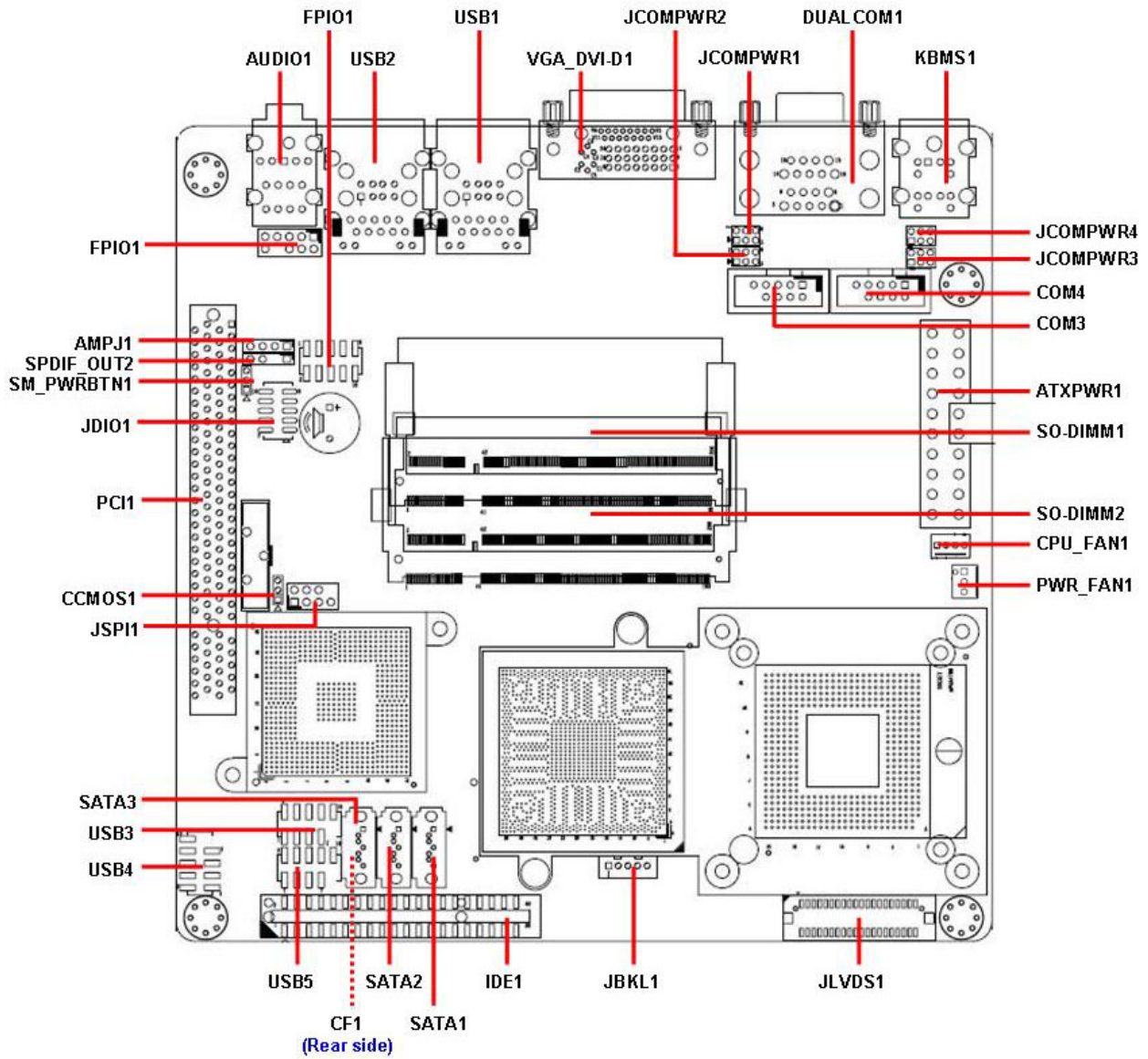

### 1.3.1 Layout Content List

Slots			
Label	Function	Note	Page
CF1A	Compact Flash connector	(Rear side)	N/A
SO-DIMM1	200-pin SODIMM slot 1		N/A
SO-DIMM2	200-pin SODIMM slot 2		N/A
PCI1	PCI slot		N/A

Jumpers			
Label	Function	Note	Page
CCMOS1	Clear CMOS	3 x 1 header, pitch 2.00mm	29
JCOMPWR1,2	COM 1, 2 RI/+5V/+12V selection	3 x 2 header, pitch 2.00mm	30
JCOMPWR3,4	COM 3, 4 RI/+5V/+12V selection	3 x 2 header, pitch 2.00mm	31
SM_PWRBTN1	SM power connector	3 x 1 header, pitch 2.00mm	32

Rear Panel Connector			
Label	Function	Note	Page
KBMS1	PS/2 keyboard and mouse	6-pin Mini-Din	33,34
DUALCOM1	Serial port connector x 2	D-sub 9-pin, male	33
VGA_DVI-D1	VGA connector DVI connector	D-sub 15-pin, female	33,34
USB1	RJ-45 Ethernet connector x 1 USB connector x 2		33,34
USB2	RJ-45 Ethernet connector x 1 USB connector x 2	(Optional for Intel 82566MM)	33,34
AUDIO1	Line-in port, Line-out port, Microphone port,	5.1 Channel Audio I/O (3 jacks)	34

<b>Internal Connector</b>			
<b>Label</b>	<b>Function</b>	<b>Note</b>	<b>Page</b>
AMPJ1	Amplifier connector	4 x 1 header, pitch 2.54mm	35
ATXPWR1	ATX power connector	10 x 2 header	35
COM3	Serial port 3 connector	5 x 2 header, pitch 2.54mm	36
COM4	Serial port 4 connector	5 x 2 header, pitch 2.54mm	36
CPU_FAN1	CPU fan connector	4 x 1 wafer, pitch 2.54mm	37
PWR_FAN1	Power fan connector	3 x 1 wafer, pitch 2.54mm	37
FPIO1	System panel connector	5 x 2 header, pitch 2.54mm	38
IDE1	Primary IDE connector	20 x 2 header, pitch 2.00mm	39
JLVDS1	LVDS connector	HIROSE DF13S-40DP-1.25V	39
JBKL1	LCD Inverter connector	5 x 1 header, pitch 2.00mm	40
JDIO1	Digital I/O connector	5 x 2 header, pitch 2.00m	40
JSPI1	SPI connector	4 x 2 header, pitch 2.54mm	41
SPDIF_OUT2	Digital Audio connector	4 x 1 header, pitch 2.54mm	41
SATA1,2,3	Serial ATA connectors 1,2,3 [black]	7-pin header	42
USB3	USB 2.0 connector	5 x 2 header, pitch 2.54mm	43
USB4	USB 2.0 connector	5 x 2 header, pitch 2.54mm	43
USB5	USB 2.0 connector	5 x 2 header, pitch 2.54mm	43



## 1.4 Central Processing Unit (CPU)

The motherboard comes with a surface mount 478-pin designed for the Intel® socket 479P Core Duo / Core Solo / Core 2 Duo CPU with 65nm process.

Take one of the marked corner (with gold triangle) on the CPU. This mark should match a specific corner on the socket to ensure correct installation.



- 
- Make sure the AC power is off before you install the CPU.
  - If installing a dual-core CPU, connect the CPU fan cable to the **CPU\_FAN1** connector to ensure system stability.
- 



- 
- Your boxed Intel® socket 479P Core Duo / Core Solo / Core 2 Duo CPU with 65nm process package should come with installation instructions for the CPU, heatsink, and the retention mechanism. If the instructions in this section do not match the CPU documentation, follow the latter.
  - Upon purchase of the motherboard, make sure that the PnP cap is on the socket and the socket contacts are not bent. Contact your retailer immediately if the PnP cap is missing, or if you see any damage to the PnP cap/socket contacts/motherboard components. Your place of purchase or local distributor will shoulder the cost of repair only if the damage is shipment/transit-related.
  - Keep the cap after installing the motherboard. Your place of purchase or local distributor will process Return Merchandise Authorization (RMA) requests only if the motherboard comes with the cap on the socket.
  - The product warranty does not cover damage to the socket contacts resulting from incorrect CPU installation/removal, or misplacement/loss/ incorrect removal of the PnP cap.
-

### 1.4.1 Installing the CPU

1. Locate the CPU socket on the motherboard.



Before installing the CPU, make sure that the socket box is facing towards you.

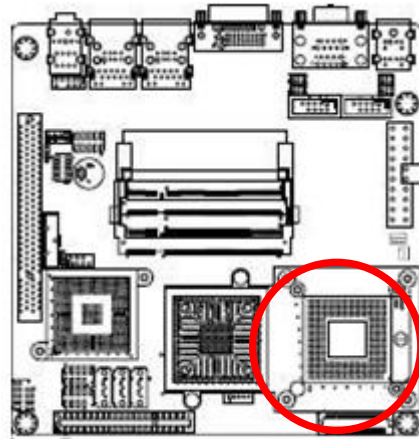

2. The processor socket comes with a screw to secure the processor, please unlock the screw first.

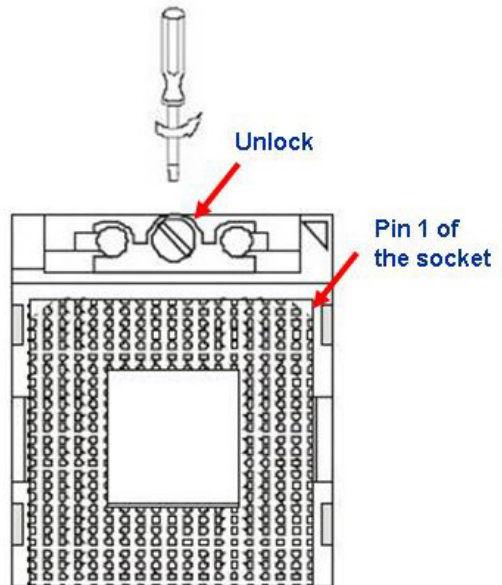

3. Position the CPU above the socket and the gold triangular mark on the CPU must align with pin 1 of the CPU socket.
4. Carefully insert the CPU into the socket until it fits in place 'Gold mark'.
5. Turn the screw to the lock position.



---

The CPU fits in only one correct orientation. DO NOT force the CPU into the socket to prevent bending the connectors on the socket and damaging the CPU.

---

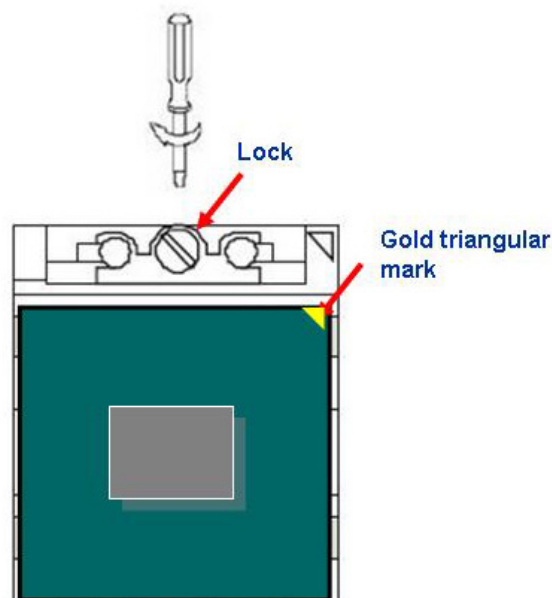

---

After installation, make sure to plug-in the ATX power cable to the motherboard.

---

### 1.4.2 Installing the CPU Heatsink and Fan

The Intel® socket 479P Core Duo / Core Solo / Core 2 Duo CPU processor requires a specially designed heatsink and fan assembly to ensure optimum thermal condition and performance.



- Install the motherboard to the chassis before you install the CPU fan and heatsink assembly.
- When you buy a boxed Intel® processor, the package includes the CPU fan and heatsink assembly. If you buy a CPU separately, make sure that you use only Intel®-certified multi-directional heatsink and fan.



If you purchased a separate CPU heatsink and fan assembly, make sure that you have properly applied Thermal Interface Material to the CPU heatsink or CPU before you install the heatsink and fan assembly.

1. Place the heatsink on top of the installed CPU, making sure that the four fasteners match the holes on the motherboard.



Orient the heatsink and fan assembly such that the CPU fan cable is closest to the CPU fan connector.

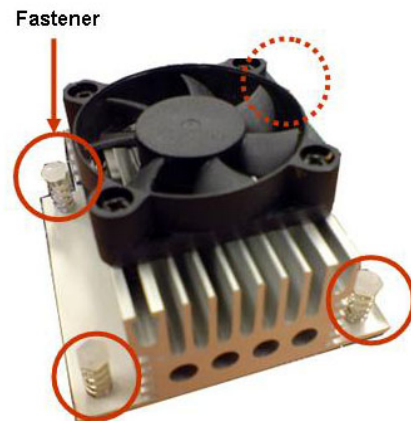
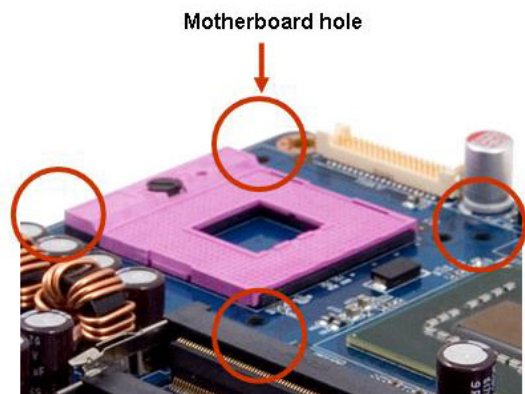

Make sure each fastener is oriented as shown, with the narrow groove directed outward.

2. Push down two fasteners at a time in a diagonal sequence to secure the heatsink and fan assembly in place.

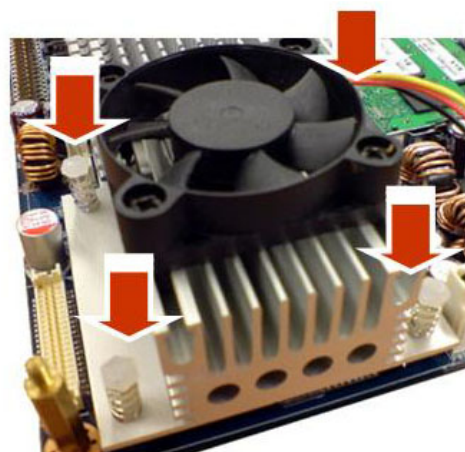
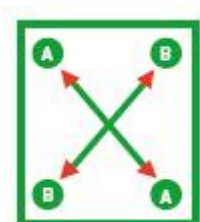

3. Connect the CPU fan cable to the connector on the motherboard labelled **CPU\_FAN1**.

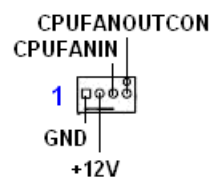
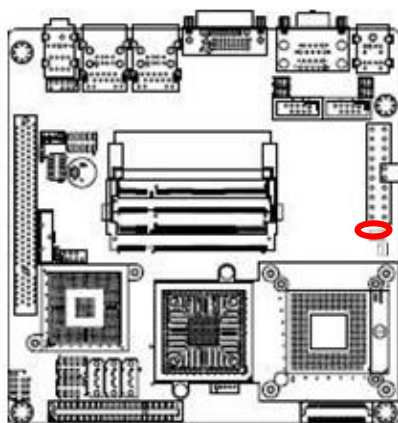

- Do not forget to connect the fan cables to the fan connectors. Insufficient air flow inside the system may damage the motherboard components, and hardware monitoring errors can occur if you fail to plug this connector.
- These are not jumpers! DO NOT place jumper caps on the fan connectors.

### 1.4.3 Uninstalling the CPU Heatsink and Fan

1. Disconnect the CPU fan cable from the connector on the motherboard.
2. Rotate each fastener counterclockwise.

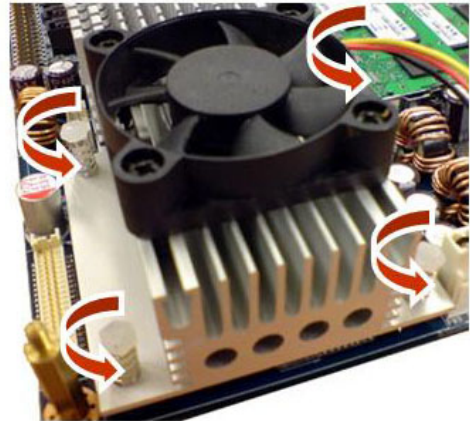

3. Pull up two fasteners at a time in a diagonal sequence to disengage the heatsink and fan assembly from the motherboard

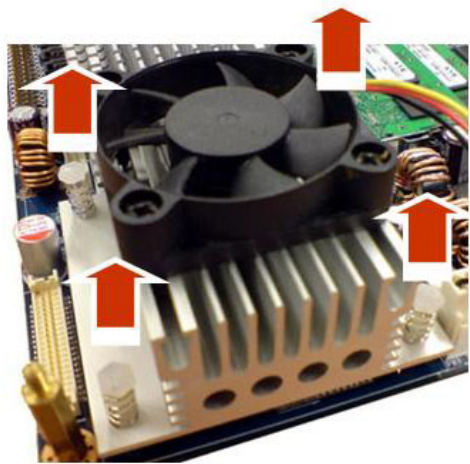
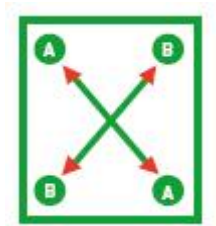

4. Carefully remove the heatsink and fan assembly from the motherboard.



---

Refer to the documentation in the boxed or stand-alone CPU fan package for detailed information on CPU fan installation.

---



## 1.5 System Memory

### 1.5.1 DIMM Sockets Location

The motherboard comes with two 200-pin Double Data Rate 2 (DDR2) SODIMM sockets.

A DDR2 module has the same physical dimensions as a DDR DIMM but has a 200-pin footprint compared to the 184-pin DDR DIMM. DDR2 DIMMs are notched differently to prevent installation on a DDR DIMM socket. The following figure illustrates the location of the sockets:

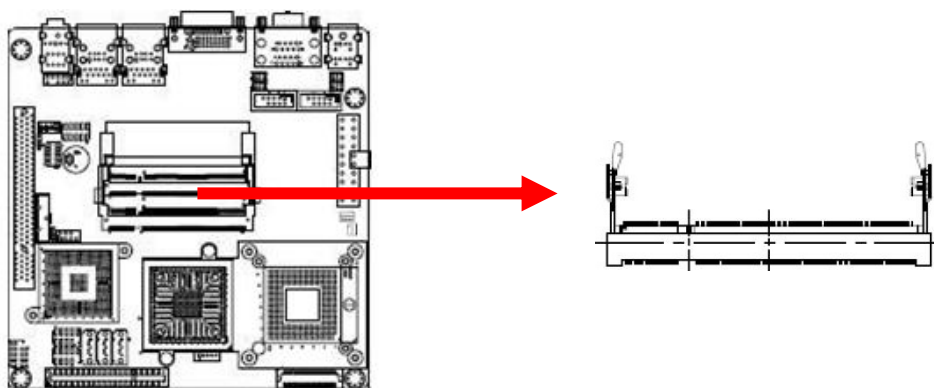

### 1.5.2 Memory Configurations

You can install 128 MB, 256 MB, 512 MB, 1GB and 2GB DDR2 SDRAM DIMMs into the SODIMM sockets using the memory configurations in this section.



- Installing DDR2 DIMM other than the recommended configurations may cause memory sizing error or system boot failure. Use any of the recommended configurations.
- Always install DIMMs with the same CAS latency. For optimum compatibility, it is recommended that you obtain memory modules from the same vendor.
- Due to chipset resource allocation, the system may detect less than 1 GB system memory when you installed one 1 GB DDR2 memory modules.
- This motherboard does not support memory modules made up of 128 Mb chips or double-sided x16 memory modules.  
Make sure that the memory frequency matches the CPU FSB (Front Side Bus). Refer to the Memory frequency/CPU FSB synchronization table.



- Memory frequency/CPU FSB synchronization

CPU FSB	DDR 2 DIMM Type	Memory Frequency
533/800MHz	DDR2 533	Max clock Freq: 266MHZ; 533Mb/s
	DDR2 667	Max clock Freq: 333MHZ; 667Mb/s



### 1.5.3 Installing a DDR2 DIMM





---

Make sure to unplug the power supply before adding or removing DIMMs or other system components. Failure to do so may cause severe damage to both the motherboard and the components.

---

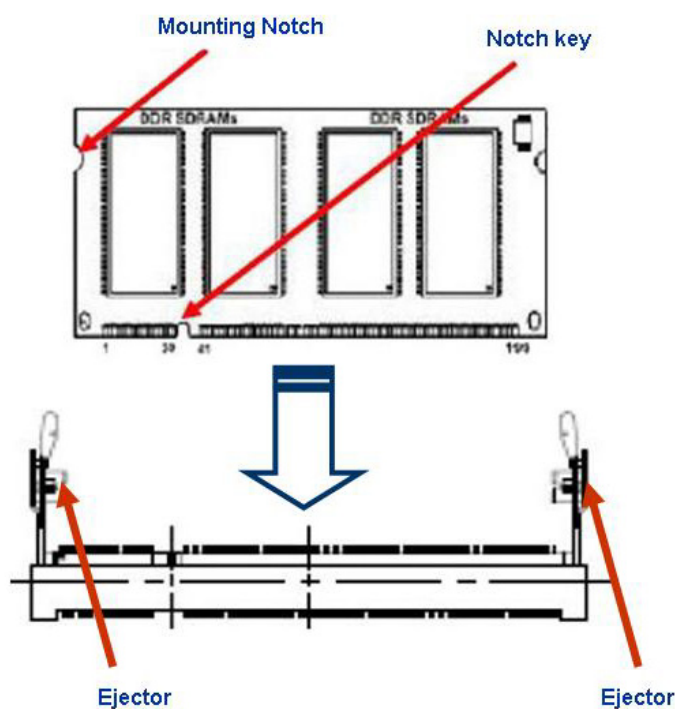
1. Locate the DIMM socket on the board.
2. Hold two edges of the DIMM module carefully, and keep away of touching its connectors.
3. Align the notch key on the module with the rib on the slot.
4. Firmly press the modules into the socket automatically snaps into the mounting notch. Do not force the DIMM module in with extra force as the DIMM module only fit in one direction.



- 
- A DDR2 DIMM is keyed with a notch so that it fits in only one direction. DO NOT force a DIMM into a socket to avoid damaging the DIMM.
  - The DDR2 DIMM sockets do not support DDR DIMMs. DO NOT install DDR DIMMs to the DDR2 DIMM socket.
-

### 1.5.4 Removing a DDR2 DIMM

1. Press the two ejector tabs on the slot outward simultaneously, and then pull out the DIMM module.

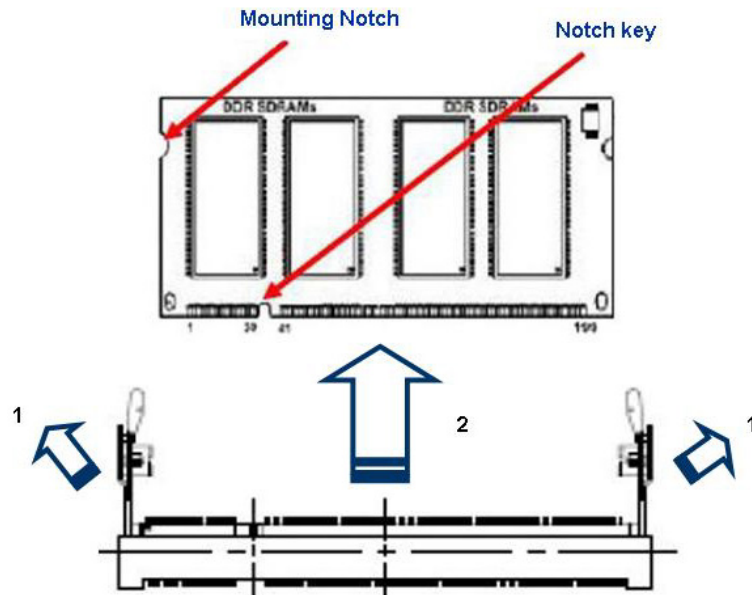

---

Support the DIMM lightly with your fingers when pressing the ejector tabs. The DIMM might get damaged when it flips out with extra force.

---

## 1.6 Expansion Slots

In the future, you may need to install expansion cards. The following sub-sections describe the slots and the expansion cards that they support.



---

Make sure to unplug the power cord before adding or removing expansion cards. Failure to do so may cause you physical injury and damage motherboard components.

---

### 1.6.1 Installing an Expansion Card

1. Before installing the expansion card, read the documentation that came with it and make the necessary hardware settings for the card.
2. Remove the system unit cover (if your motherboard is already installed in a chassis).
3. Remove the bracket opposite the slot that you intend to use. Keep the screw for later use.
4. Align the card connector with the slot and press firmly until the card is completely seated on the slot.
5. Secure the card to the chassis with the screw you removed earlier.
6. Replace the system cover.

### 1.6.2 Configuring an Expansion Card

After installing the expansion card, configure it by adjusting the software settings.

1. Turn on the system and change the necessary BIOS settings if any.
2. Assign an IRQ to the card if needed. Refer to the tables on the next page.
3. Install the software drivers for the expansion card.

### 1.6.3 Standard Interrupt Assignments

IRQ	Priority	Standard Function
0	1	System Timer
1	2	Keyboard Controller
2	-	Redirect to IRQ#9
3	11	IRQ holder for PCI steering*
4	12	Communications Port (COM1)*
5	13	IRQ holder for PCI steering*
6	14	Floppy Disk Controller
7	15	Printer Port (LPT)*
8	3	System CMOS/Rear Time
9	4	IRQ holder for PCI steering*
10	5	IRQ holder for PCI steering*
11	6	IRQ holder for PCI steering*
12	7	PS/2 Compatible Mouse Port*
13	8	Numeric Data Processor
14	9	Primary IDE Channel
15	10	Secondary IDE Channel

\* These IRQs are usually available for ISA or PCI device.

### 1.6.4 PCI Slots

EMX-965GME has one PCI slot. The PCI slot supports cards such as a LAN card, SCSI card, USB card, and other cards that comply with PCI specifications. The figure shows a LAN card installed on a PCI slot.



## 1.7 Jumpers

### 1.7.1 Clear CMOS (CCMOS1)

This jumper allows you to clear the Real Time Clock (RTC) RAM in CMOS. You can clear the CMOS memory of date, time, and system setup parameters by erasing the CMOS RTC RAM data. The onboard button cell battery powers the RAM data in CMOS, which include system setup information such as system passwords. To erase the RTC RAM:

1. Turn OFF the computer and unplug the power cord.
2. Remove the onboard battery.
3. Move the jumper cap from pins 1-2 (default) to pins 2-3. Keep the cap on pins 2-3 for about 5~10 seconds, then move the cap back to pins 1-2.
4. Re-install the battery.
5. Plug the power cord and turn ON the computer.
6. Hold down the <Del> key during the boot process and enter BIOS setup to re-enter data.



Except when clearing the CMOS, never remove the cap on CLRRTC jumper default position. Removing the cap will cause system boot failure!

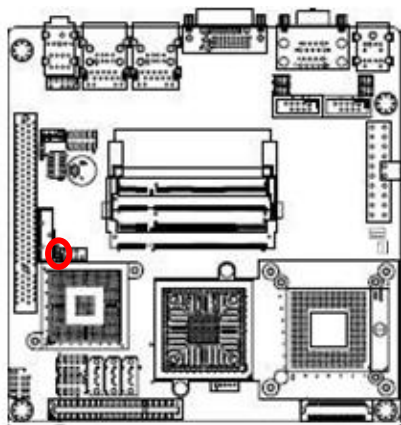

**Normal (Default)**



**Clear RTC**



1.7.2 COM1 RI/+5V/+12V Selection (JCOMPWR1, JCOMPWR2)

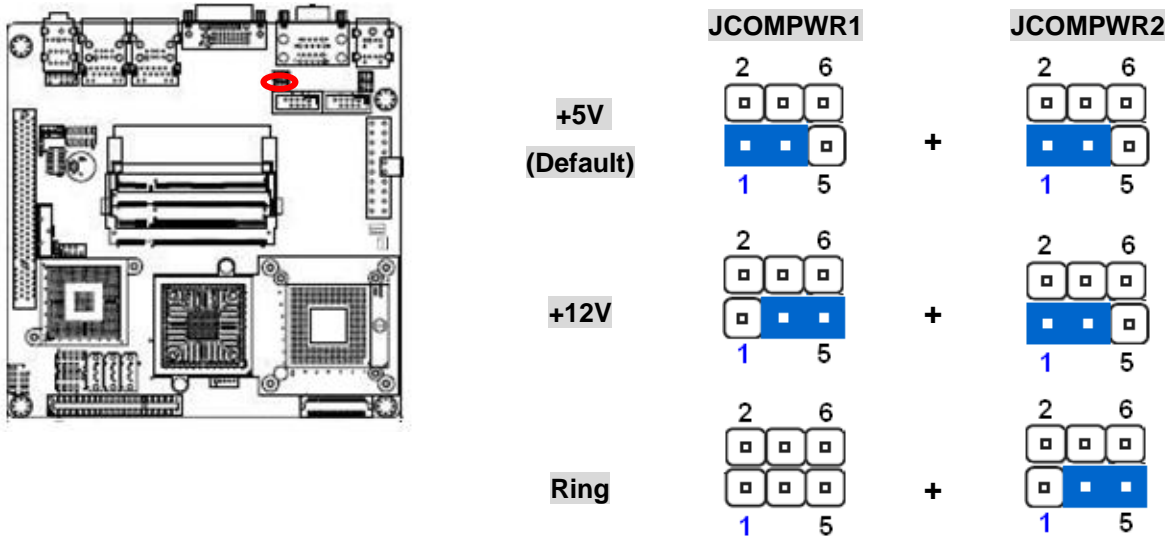

1.7.3 COM2 RI/+5V/+12V Selection (JCOMPWR1, JCOMPWR2)

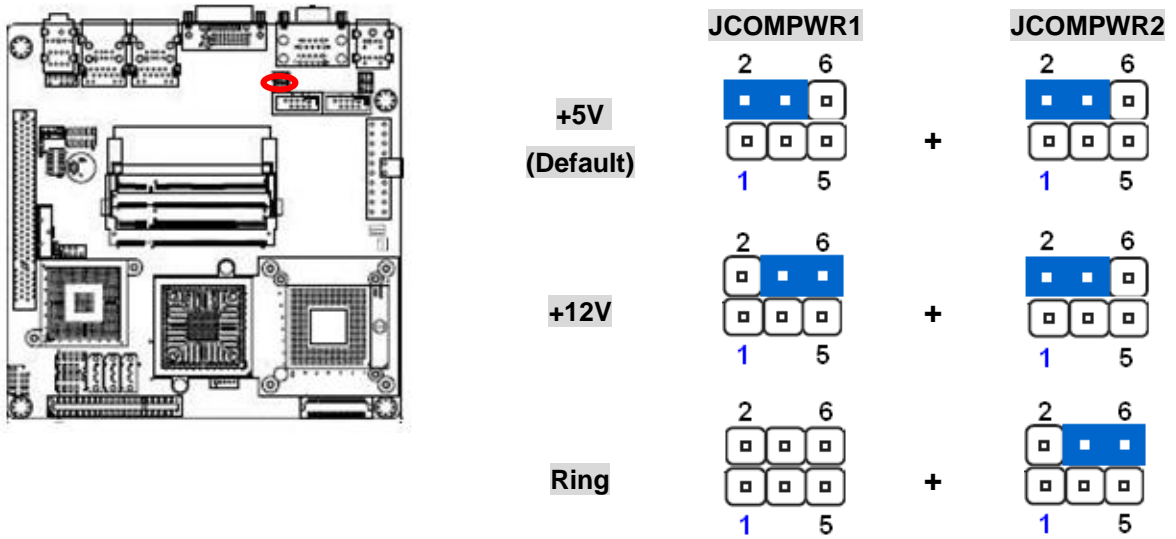

1.7.4 COM3 RI/+5V/+12V Selection (JCOMPWR3, JCOMPWR4)

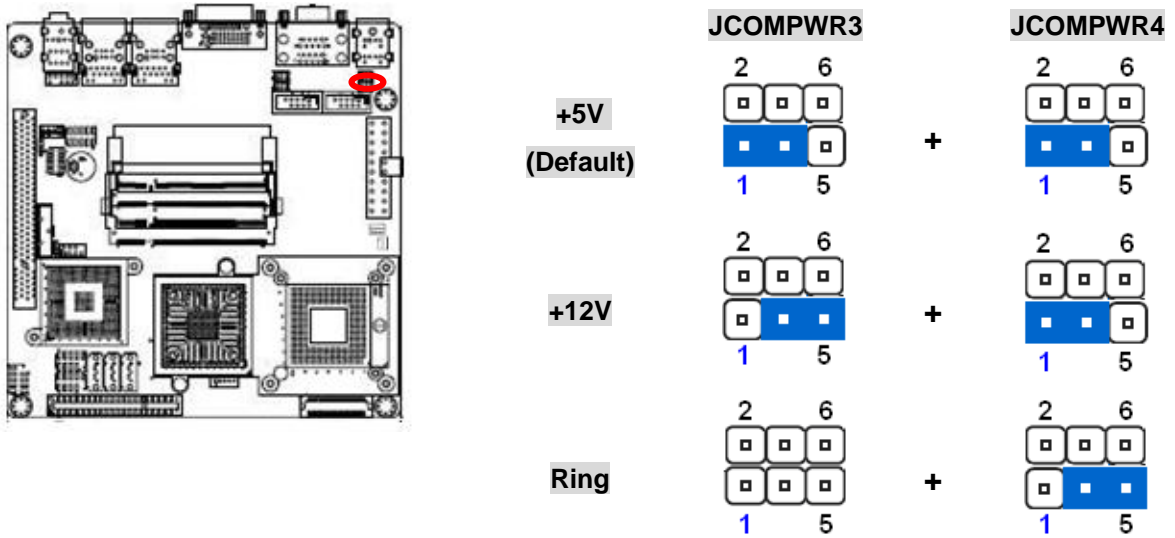

1.7.5 COM4 RI/+5V/+12V Selection (JCOMPWR3, JCOMPWR4)

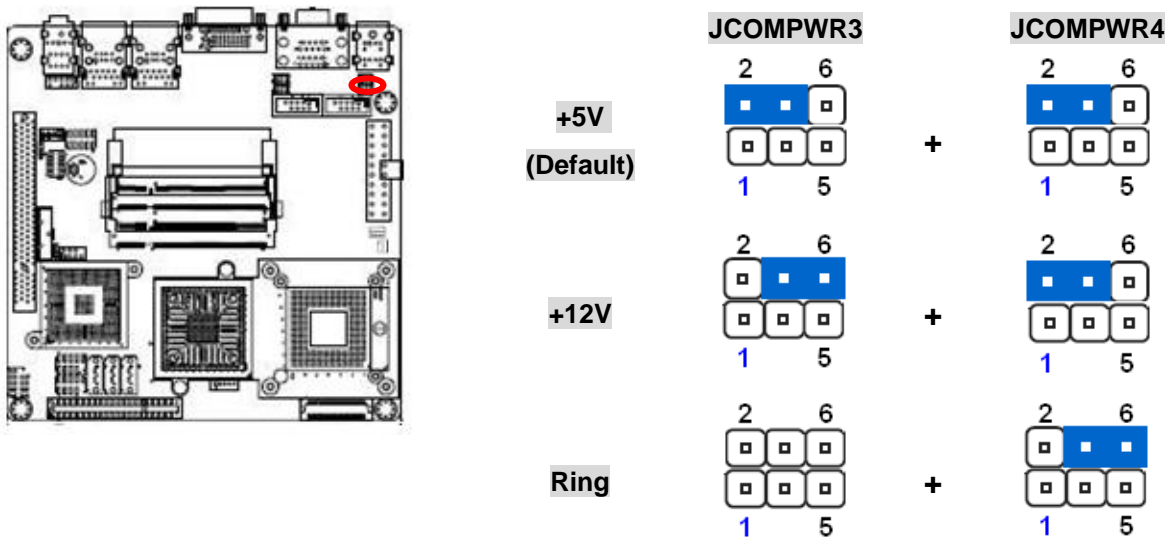

### 1.7.6 SM Power Connector (SM\_PWRBTN1)

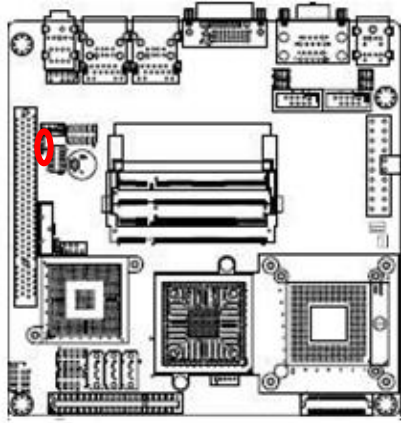

**ATX Mode (Default)**



**AT Mode**





## 1.8 Connectors

### 1.8.1 Rear Panel Connectors

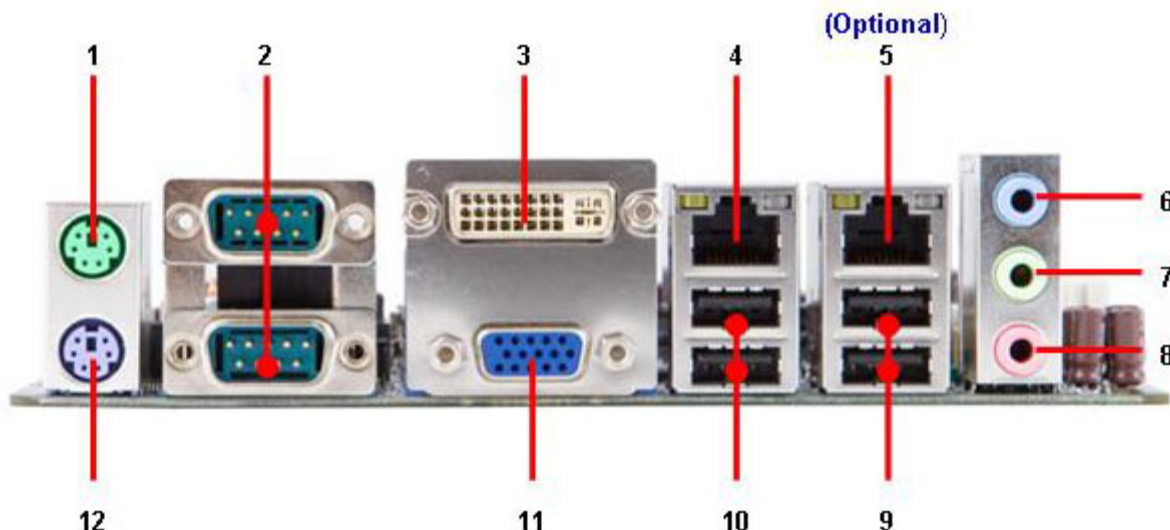

No	Label	Function	Description
1	KBMS1	PS/2 mouse connector	The standard PS/2 mouse DIN connector is for a PS/2 mouse.
2	DUALCOM1	Serial port connector x 2	D-sub 9-pin, male
3	VGA_DVI-D1	DVI port	
4,5	USB1, USB2	LAN (RJ-45) connector	This port allows Gigabit connection to a Local Area Network (LAN) through a network hub. Refer to the table below for the LAN port LED indications. The optional 10/100 Mbps LAN controller allows 10/100 Mbps connection to a Local Area Network (LAN) through a network hub.

LAN port

ACT / LINK LED		SPEED LED	
Status	Description	Status	Description
OFF	No link	OFF	10Mbps connection
Orange	Linked	ORANGE	100Mbps connection
Blinking	Data activity	GREEN	1Gbps connection

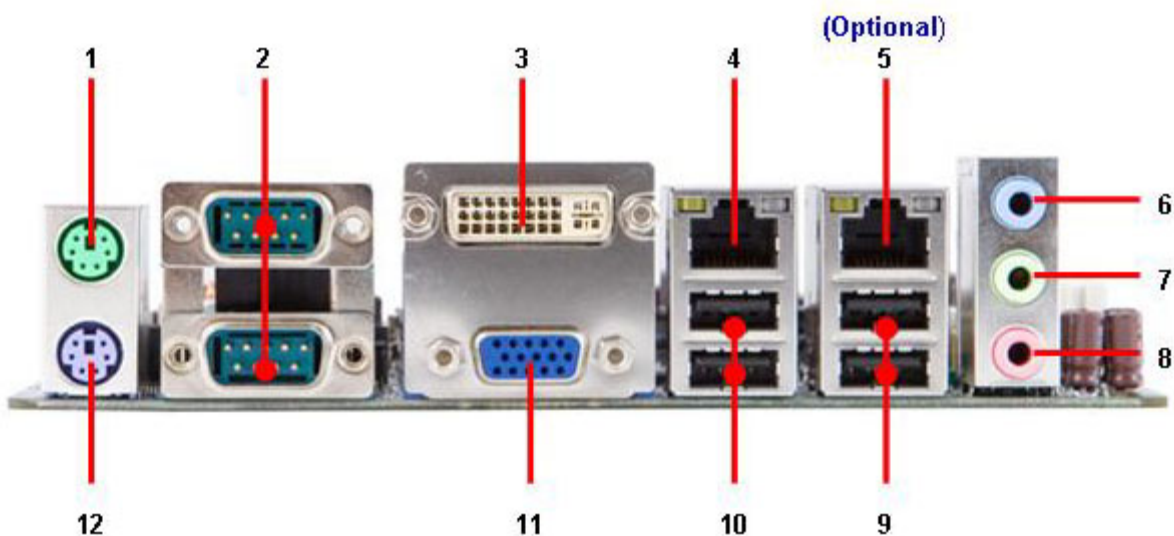

No	Label	Function	Description
6	AUDIO1	Line-In port (Light Blue).	This port connects a tape, CD, DVD player, or other audio sources.
7	AUDIO1	Line-Out port (Lime)	This port connects a headphone or a speaker. In 4-channel, 6-channel, and 8-channel configuration, the function of this port becomes Front Speaker Out.
8	AUDIO1	Microphone port (Pink)	This port connects a microphone.
9,10	USB1, USB2	USB 2.0 connector	These four 4-pin Universal Serial Bus (USB) ports are available for connecting USB 2.0 devices.
11	VGA_DVI-D1	VGA port	This 15-pin port is for a VGA monitor or other VGA-compatible devices.
12	KBMS1	PS/2 KB connector	This port is for a PS/2 keyboard

### 1.8.2 Amplifier Connector (AMPJ1)

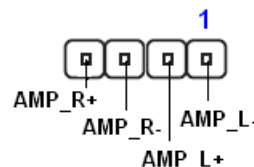
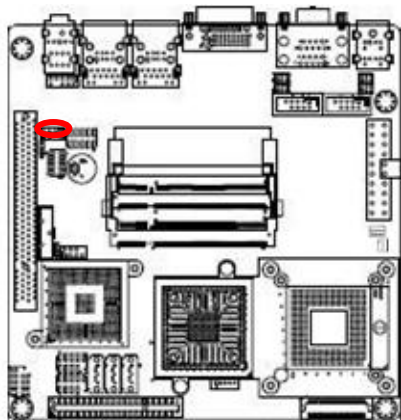

### 1.8.3 ATX Power Connector (ATXPWR1)

This connector is for an ATX Micro-Fit power supply. The plugs from the power supply are designed to fit these connectors in only one orientation. Find the proper orientation and push down firmly until the connectors completely fit.

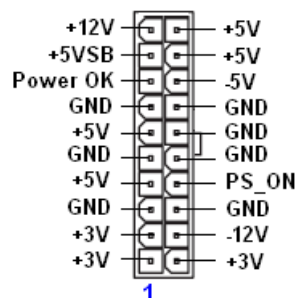
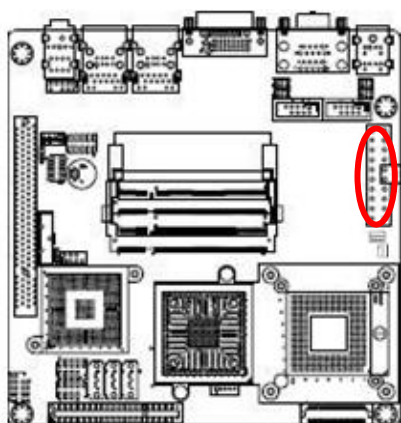

### Important notes on the Motherboard Power Requirements



- Make sure that your ATX 12V power supply can provide 8A on the +12V lead and at least 1A on the +5-volt standby lead (+5VSB). The minimum recommended wattage is 230W, or 300W for a fully configured system. The system can become unstable and might experience difficulty powering up if the power supply is inadequate.
- You must install a PSU with a higher power rating if you intend to install additional devices.

### 1.8.4 Serial Port 3 Connector (COM3)

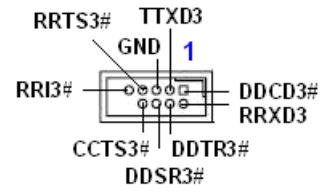
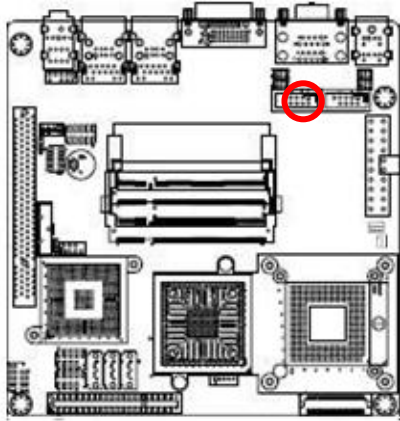

### 1.8.5 Serial Port 4 Connector (COM4)

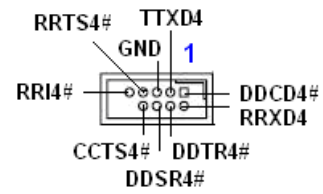
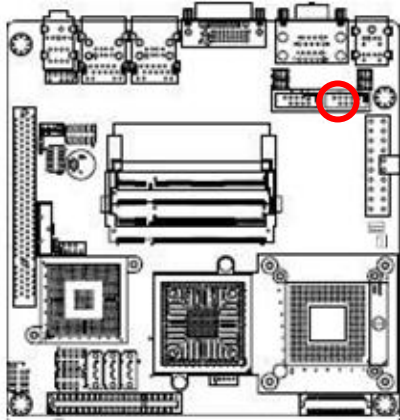

### 1.8.6 CPU Fan Connector (CPU\_FAN1)

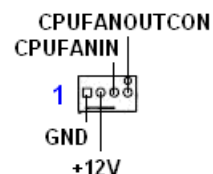
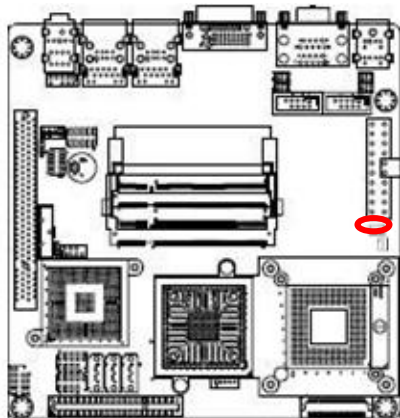

- Do not forget to connect the fan cables to the fan connectors. Insufficient air flow inside the system may damage the motherboard components, and hardware monitoring errors can occur if you fail to plug this connector.
- These are not jumpers! DO NOT place jumper caps on the fan connectors.

### 1.8.7 Power Fan Connector (PWR\_FAN1)

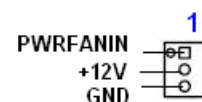
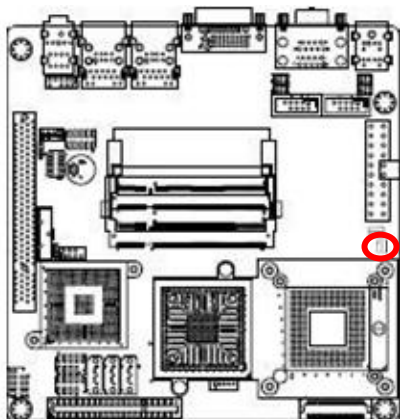

- Do not forget to connect the fan cables to the fan connectors. Insufficient air flow inside the system may damage the motherboard components, and hardware monitoring errors can occur if you fail to plug this connector.
- These are not jumpers! DO NOT place jumper caps on the fan connectors.

### 1.8.8 System Panel Connector (FPIO1)

This connector supports several chassis-mounted functions.

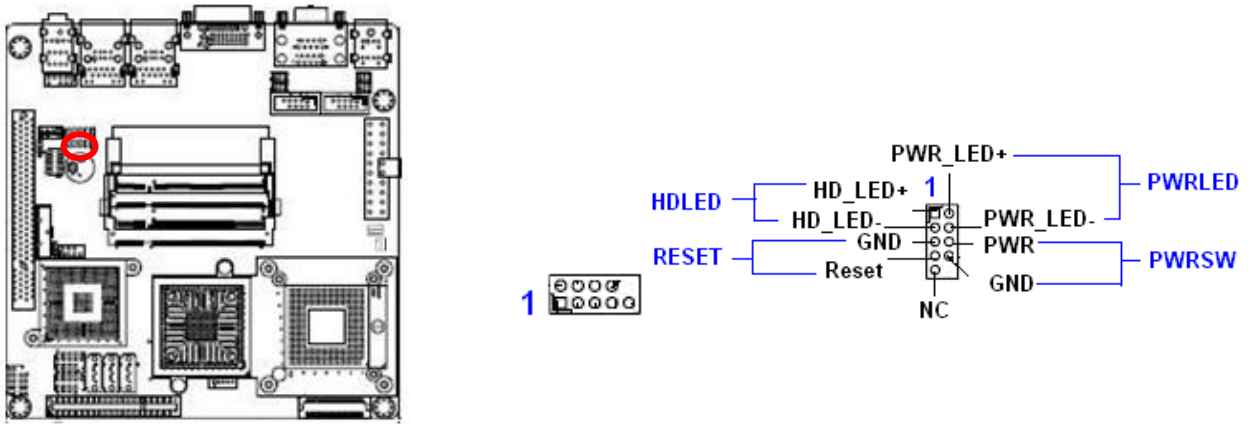

- **System Power LED (2-pin PWRLED)**  
This 2-pin connector is for the system power LED. Connect the chassis power LED cable to this connector. The system power LED lights up when you turn on the system power, and blinks when the system is in sleep mode.
- **ATX Power Button/Soft-off Button (2-pin PWRSW)**  
This connector is for the system power button. Pressing the power button turns the system on or puts the system in sleep or soft-off mode depending on the BIOS settings. Pressing the power switch for more than four seconds while the system is ON turns the system OFF.
- **Hard Disk Drive Activity LED (2-pin HDLED)**  
This 2-pin connector is for the HDD Activity LED. Connect the HDD Activity LED cable to this connector. The IDE LED lights up or flashes when data is read from or written to the HDD.
- **Reset Button (2-pin RESET)**  
This 2-pin connector is for the chassis-mounted reset button for system reboot without turning off the system power.

### 1.8.9 Primary IDE Connector (IDE1)

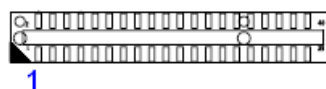
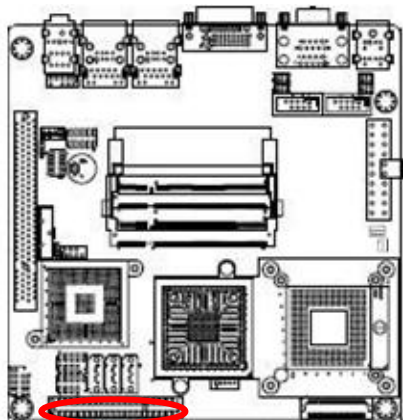

- Orient the red markings (usually zigzag) on the IDE cable to Pin 1.



- Please DO NOT use IDE1 and SATA2 at the same time. This is an incompatible conflict.

### 1.8.10 LVDS Connector (JLVDS1)

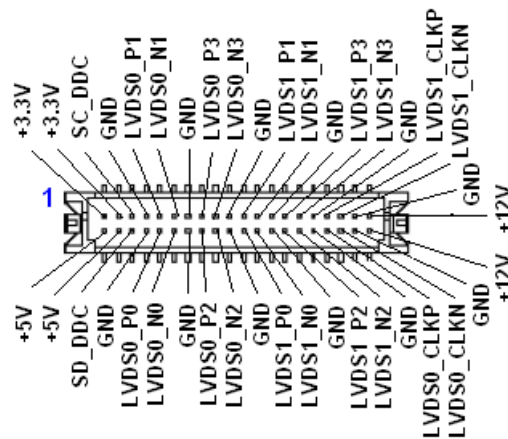
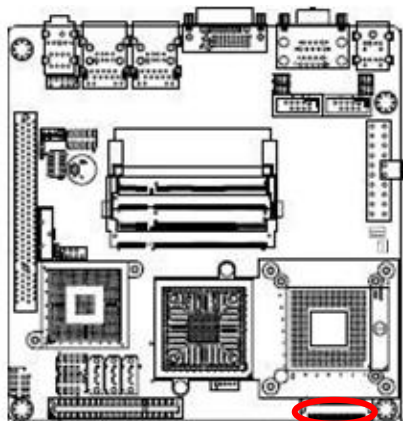



1.8.11 LCD Inverter Connector (JBKL1)

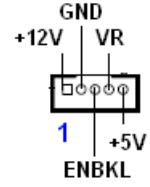
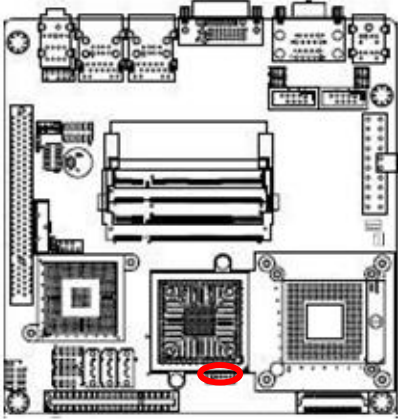

● Signal Description

Signal	Signal Description
VR	Bright adjust. $V_{adj}=0.75V \sim 4.25V$ (Recommended: $4.7K\Omega, > 1/16W$ )
ENBK	LCD backlight ON/OFF control signal

1.8.12 Digital I/O Connector (JDIO1)

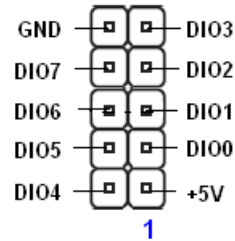
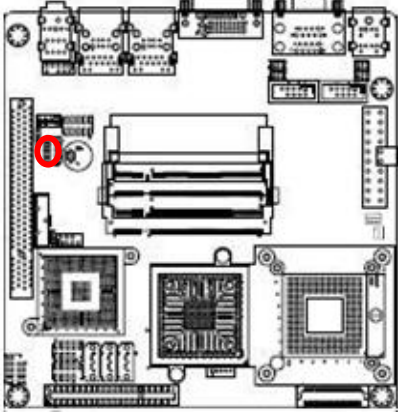



### 1.8.13 SPI Connector (JSPI1)

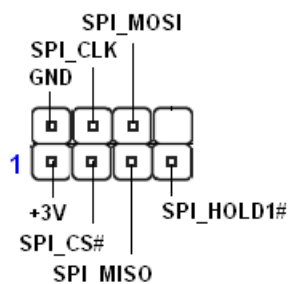
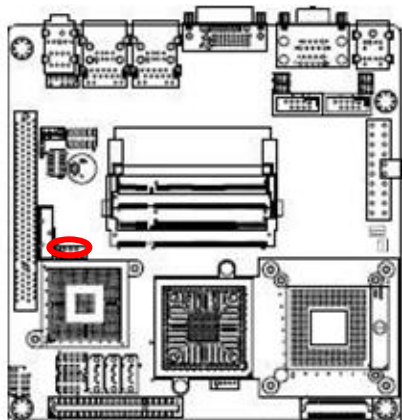

### 1.8.14 Digital Audio Connector (SPDIF\_OUT2)

This connector is for an additional Sony/Philips Digital Interface (S/PDIF) port(s). Connect the S/PDIF module cable to this connector, then install the module to a slot opening at the back of the system chassis.

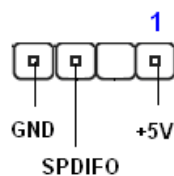
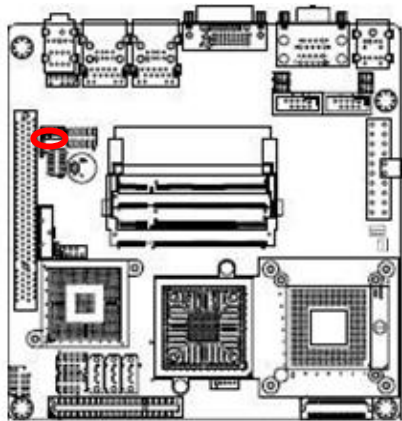



---

The S/PDIF module is purchased separately.

---

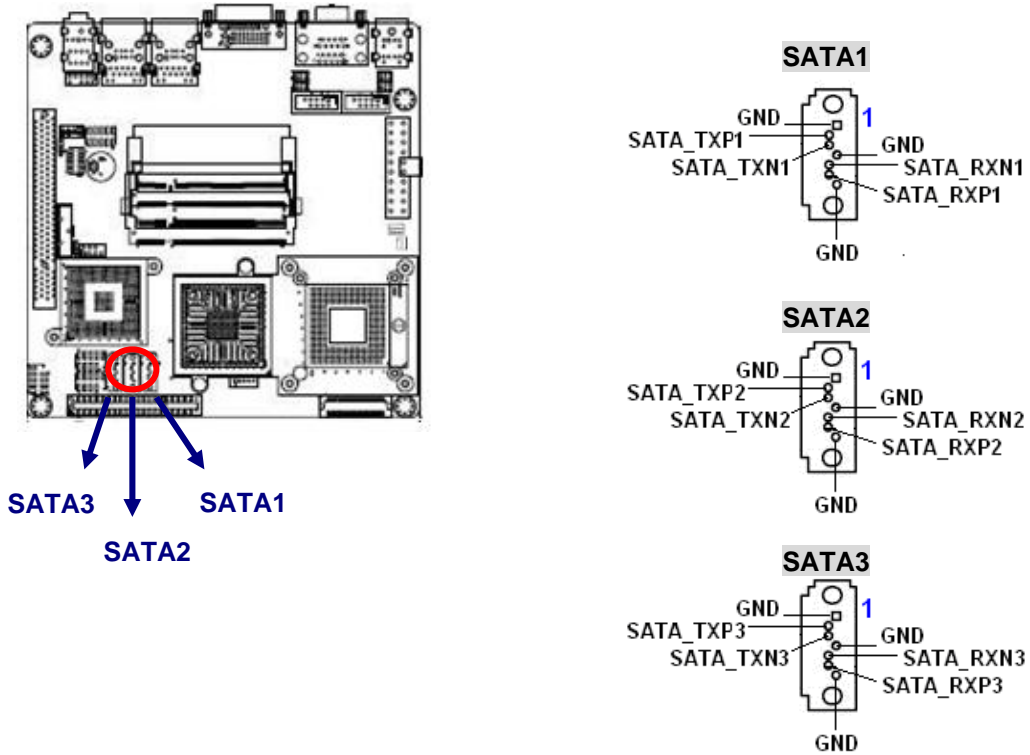
### 1.8.15 Serial SATA Connector [Black] (SATA1, SATA2, SATA3)



- Install the Windows® 2000 Service Pack 4 or the Windows® XP Service Pack1 before using Serial ATA.
- When using the connectors in Standard IDE mode, connect the primary (boot) hard disk drive to the SATA1 connector.



- Please DO NOT use IDE1 and SATA2 at the same time. This is an incompatible conflict.

### 1.8.16 USB 2.0 Connector (USB3, USB4, USB5)

These connectors are for USB 2.0 ports. Connect the USB/GAME module cable to any of these connectors, then install the module to a slot opening at the back of the system chassis. These USB connectors comply with USB 2.0 specification that supports up to 480 Mbps connection speed.

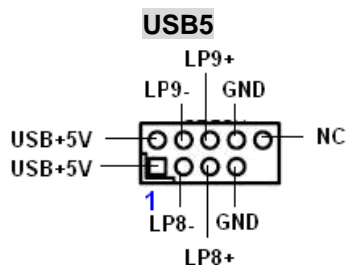
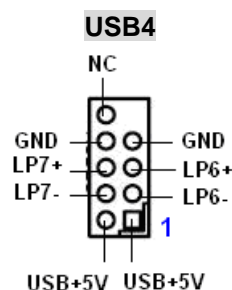
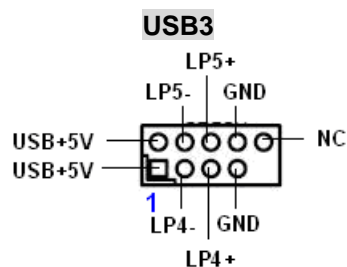
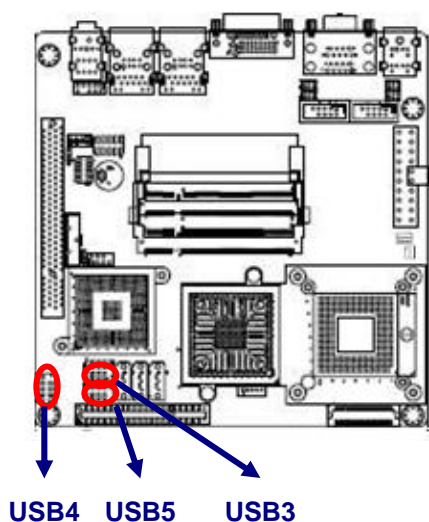

Never connect a **1394 cable** to the USB connectors. Doing so will damage the motherboard!



The USB module is purchased separately.