

SPECIFICATION FOR LCM MODULE

MODULE NO.: LCM2002B-FS50-060A**REVISION NO.: A**

Customer Approval:

| |
|--|
| |
|--|

| | SIGNATURE |
|-------------|-----------|
| PREPARED BY | |
| VERIFIED BY | |
| APPROVED BY | |

RECORDS OF REVISION

| Date | Rev. | Description | Page | Design by |
|------|------|-------------|------|-----------|
| | | | | |
| | | | | |
| | | | | |
| | | | | |
| | | | | |
| | | | | |
| | | | | |
| | | | | |
| | | | | |
| | | | | |

Contents

1. SPECIFICATIONS

- 1.1 Features**
- 1.2 Mechanical Specifications**
- 1.3 Absolute Maximum Ratings**
- 1.4 DC Electrical Characteristics**
- 1.5 Backlight & LED Characteristics**

2. MODULE STRUCTURE

- 2.1 Counter Drawing**
- 2.2 Interface Pin Description**
- 2.3 Timing Characteristics**
- 2.4 Instruction Table**
- 2.5 Character Generator ROM**
- 2.6 Inspection Specification**

1. SPECIFICATIONS

1.1 Features

| Item | Standard Value |
|-------------------|---------------------------------|
| Display Type | 20characters × 2 lines |
| LCD Type | FSTN Positive Transflective |
| Driver Condition | LCD Module : 1/16Duty , 1/5Bias |
| Viewing Direction | 6 O'clock |
| Backlight Type | White |
| Interface | 8-bit MPU interface |
| Driver IC | UCI7066 |

1.2 Mechanical Specifications

| Item | Standard Value | Unit |
|-------------------|--------------------------|------|
| Outline Dimension | 146.0(W)×43.0(H)×13.2(T) | mm |
| Viewing Area | 123.0(L) X 23.0(W) | mm |
| Dot size | 0.92(W) × 1.10(H) | mm |
| Dot pitch | 6.0(W) × 9.75(H) | mm |
| Character size | 4.48(W) × 9.22(H) | mm |

1.3 Absolute Maximum Ratings

| Item | Symbol | Condition | Min. | Max. | Unit |
|-----------------------------|-----------------|------------|--------|-----------|------|
| System Power Supply Voltage | VDD | - | 4.5 | 5.5 | V |
| LCD Driver Supply Voltage | VLCD | - | VDD-12 | VDD-0.3 | V |
| Input Voltage | V _{IN} | - | -0.3 | VDD + 0.3 | V |
| Operating Temperature | T _{OP} | - | -20 | 70 | °C |
| Storage Temperature | T _{ST} | - | -25 | 80 | °C |
| Storage Humidity | H _D | Ta < 40 °C | 20 | 70 | %RH |

1.4 DC Electrical Characteristics

VDD = 5.0V ± 0.5V, GND = 0V, Ta = 25°C

| Item | Symbol | Condition | Min. | Typ. | Max. | Unit |
|----------------------|-----------------|-----------|--------|------|--------|------|
| Logic Supply Voltage | VDD | - | 4.5 | 5.0 | 5.5 | V |
| Input High Voltage | V _{IH} | - | 0.8VDD | - | VDD | V |
| Input Low Voltage | V _{IL} | - | GND | - | 0.3VDD | V |
| Output High Voltage | V _{OH} | - | 0.7VDD | - | VDD | V |
| Output Low Voltage | V _{OL} | - | GND | - | 0.2VDD | V |

1.5 Backlight Characteristics

LCD Module with White LED Backlight

Electrical / Optical Characteristics

Ta = 25°C

| Item | Symbol | Conditions | Min. | Typ. | Max. | Unit |
|-------------------------------------|--------------------|---|------|------|------|-------------------|
| Forward Voltage | V _f | I _f =60mA | 2.9 | 3.1 | 3.3 | V |
| Reverse Current | I _r | I _f =5v | | | -- | uA |
| Average Brightness | | I _v I _f =60mA | | | | cd/m ² |
| Wavelength (Without LCD) | λ _d | I _f =60mA | -- | -- | -- | nm |
| Luminous Intensity (without LCD) | L _v Sub | I _f =60mA | | | | cd/m ² |
| Uniformity | Δ% | I _v Min / I _v Max *100% | -- | - | - | % |
| Color | White | | | | | |

2. MODULE STRUCTURE

2.1 Counter Drawing

2.1.1 LCM Mechanical Diagram

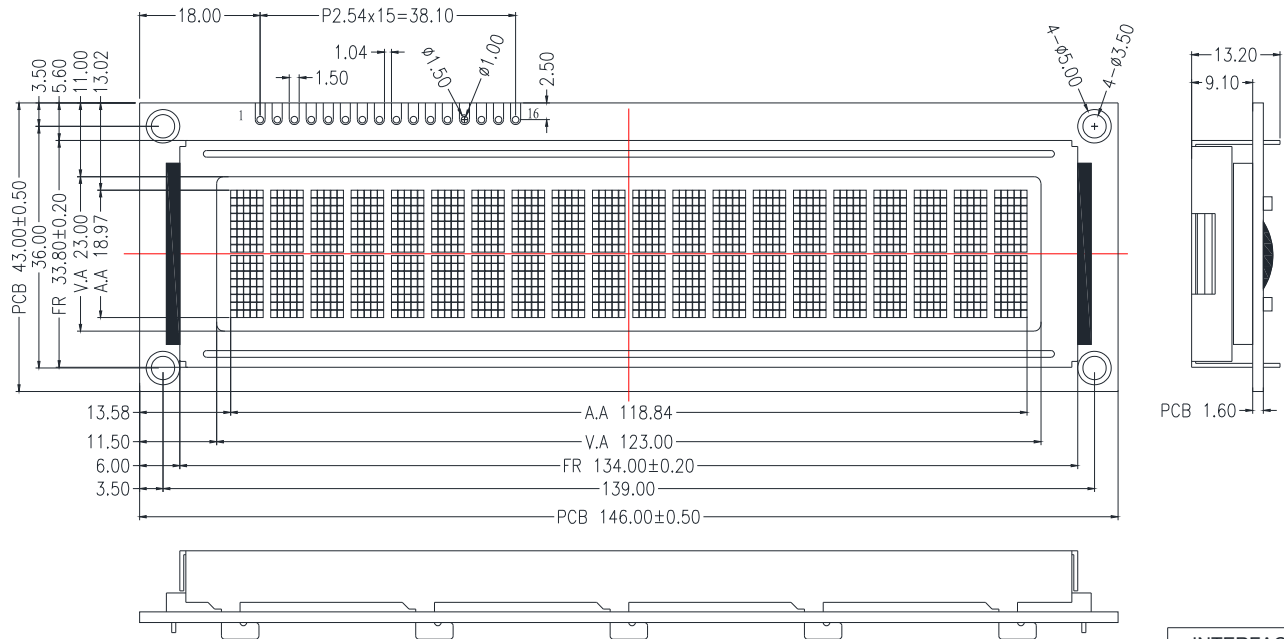

SPECIFICATION:

- 1). FSTN/POSITIVE/ TRANSFLECTIVE
- 2). DUTY:1/16. BIAS:1/5. VOP=4.5V
- 3). VIEWING ANGLE: 6 O' CLOCK
- 4). OPERATING TEMPERATURE: -20~70°C
STORAGE TEMPERATURE: -30~80°C
- 5). BACKLIGHT: WHITE, 4 pcs LED ,VF=3.1±0.2,IF=4x15mA
- 6). DRIVE IC:UCI7066
- 7). DRIVE POWER: VDD=5.0V

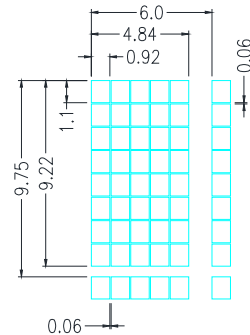

| INTERFACE | |
|-----------|---------|
| 1 | VSS |
| 2 | VDD(5V) |
| 3 | V0 |
| 4 | RS |
| 5 | RW |
| 6 | E |
| 7 | DB0 |
| 8 | DB1 |
| 9 | DB2 |
| 10 | DB3 |
| 11 | DB4 |
| 12 | DB5 |
| 13 | DB6 |
| 14 | DB7 |
| 15 | LED-A |
| 16 | LED-K |

2.2 Interface Pin Description

| No | Symbol | Function |
|------|---------|-----------------------------------|
| 1 | VSS | Ground (0V) |
| 2 | VDD | Supply Voltage for Logic (+5.0V) |
| 3 | VO | Contrast Adjustment |
| 4 | RS | Data/Instruction Select |
| 5 | R/W | Read/Write Select |
| 6 | E | Enable Signal |
| 7-14 | DB0-DB7 | Data Bus |
| 15 | LED_A | Power Supply + |
| 16 | LED_K | Power Supply- |

Character located 1 2 3 4 5 6 7 8 9 10 11 12 13 14 15 16 17 18 19 20

| | | | | | | | | | | | | | | | | | | | | |
|--------------|----|----|----|----|----|----|----|----|----|----|----|----|----|----|----|----|----|----|----|----|
| DDRAMAddress | 00 | 01 | 02 | 03 | 04 | 05 | 06 | 07 | 08 | 09 | 0A | 0B | 0C | 0D | 0E | 0F | 10 | 11 | 12 | 13 |
| DDRAMAddress | 40 | 41 | 42 | 43 | 44 | 45 | 46 | 47 | 48 | 49 | 4A | 4B | 4C | 4D | 4E | 4F | 50 | 51 | 52 | 53 |

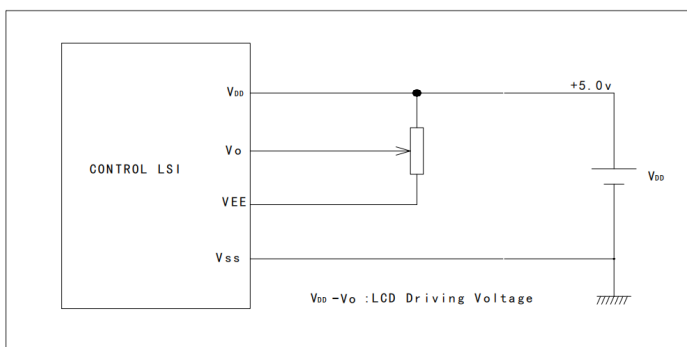
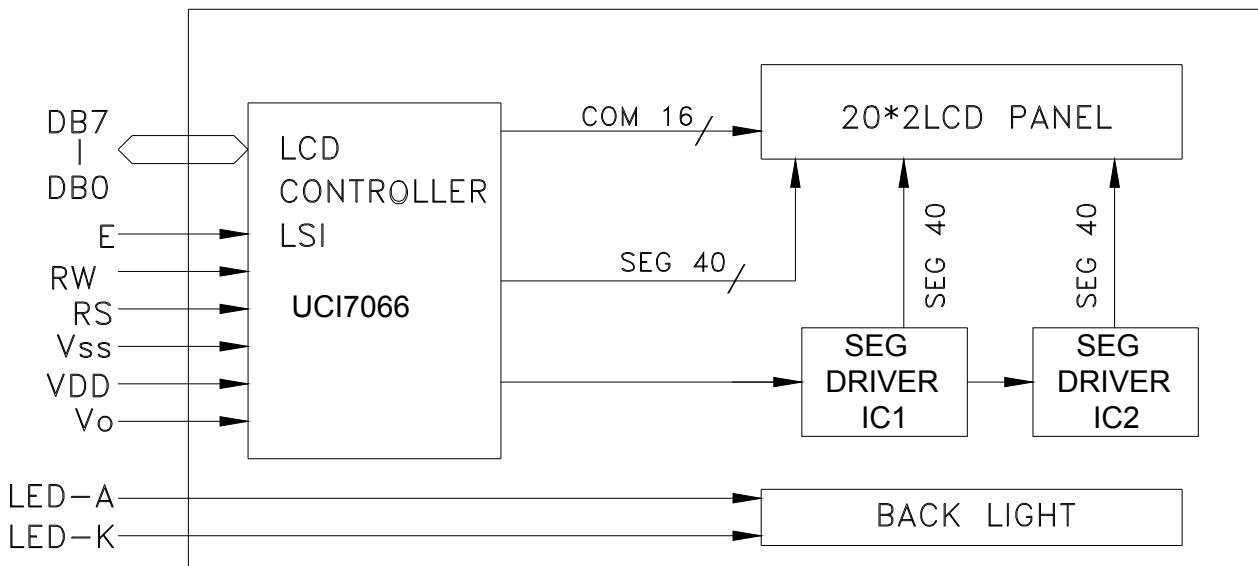

2.3 Timing Characteristics

DC Characteristics

| Characteristics | Symbol | Limit | | | Unit | Test Condition |
|----------------------------|------------------|--------|-------|--------|------|--|
| | | Min. | Typ. | Max. | | |
| Operating Current | IDD | - | 0.55 | 0.8 | mA | External clock (Note) |
| Input High Voltage | V _{IH1} | 2.2 | - | VDD | V | Pins:(E, RS, R/W, DB7 - 0) |
| Input Low Voltage | V _{IL1} | -0.3 | - | 0.6 | V | |
| Input High Voltage | V _{IH2} | VDD-1 | - | VDD | V | Pin OSC1 |
| Input Low Voltage | V _{IL2} | -0.2 | - | 1.0 | V | Pin OSC1 |
| Input High Current | I _{IH} | -2.0 | - | 2.0 | μA | Pins: (RS, R/W, DB7 - 0) |
| Input Low Current | I _{IL} | -20.0 | -50.0 | -100.0 | μA | VDD = 5.0V |
| Output High Voltage (TTL) | V _{OH1} | 2.4 | - | VDD | V | I _{OH} = - 0.1mA Pins: DB7 - 0 |
| Output Low Voltage (TTL) | V _{OL1} | - | - | 0.4 | V | I _{OL} = 0.1mA Pins: DB7 - 0 |
| Output High Voltage (CMOS) | V _{OH2} | 0.9VDD | - | VDD | V | I _{OH} = - 40.0μA, Pins: CL1, CL2, M, D |
| Output Low Voltage (CMOS) | V _{OL2} | - | - | 0.1VDD | V | I _{OL} = 40.0μA, Pins: CL1, CL2, M, D |
| Driver ON Resistance (COM) | R _{COM} | - | - | 20.0 | KΩ | I _O = ±50.0μA, V _{LCD} = 4.0V Pins: COM16 - 1 |
| Driver ON Resistance (SEG) | R _{SEG} | - | - | 30.0 | KΩ | I _O = ±50.0μA, V _{LCD} = 4.0V Pins: SEG40 - 1 |
| LCD Voltage | V _{LCD} | 3.0 | - | 11.0 | V | VDD - V5, 1/4 bias or 1/5 bias |

Note: F_{OSC} = 250.0KHz, VDD = 5.0V, pin E = "L", RS, R/W, DB7 - 0 are open, all outputs are no loads.

AC Characteristics

| Characteristics | Symbol | Limit | | | Unit | Test Condition |
|-----------------|-------------------|-------|-------|-------|------|------------------------------|
| | | Min. | Typ. | Max. | | |
| OSC Frequency | F _{OSC1} | 190.0 | 270.0 | 350.0 | KHz | VDD = 5.0V Rf = 91.0KΩ±2% |

Timing Diagram
Writing mode

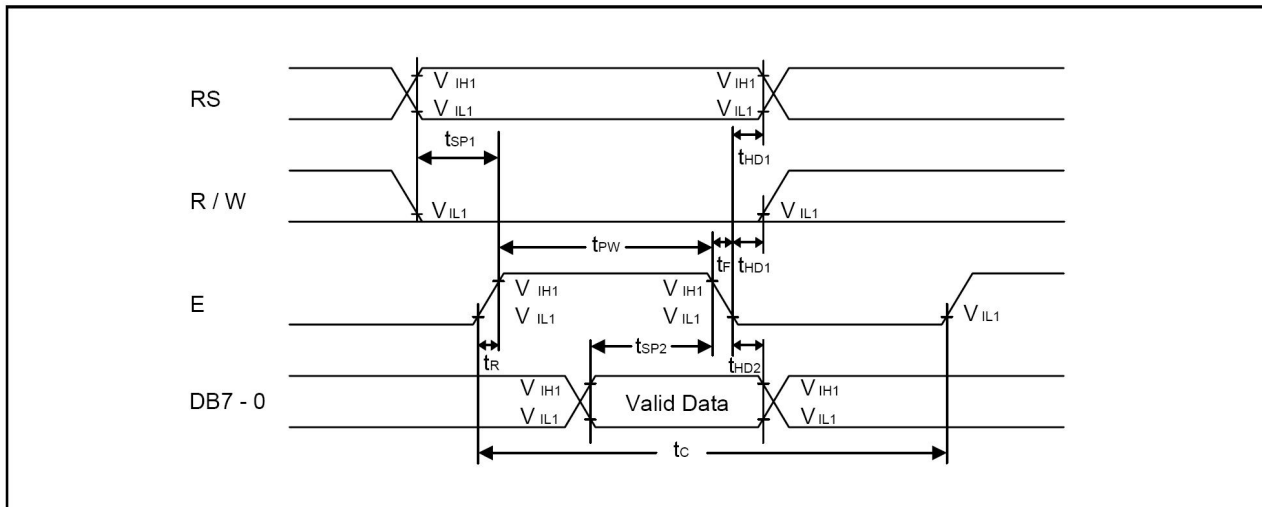

| Characteristics | Symbol | Limit | | | Unit | Test Condition |
|--------------------|------------|-------|------|------|------|------------------|
| | | Min. | Typ. | Max. | | |
| E Cycle Time | t_c | 400.0 | - | - | ns | Pin E |
| E Pulse Width | t_{PW} | 150.0 | - | - | ns | Pin E |
| E Rise/Fall Time | t_R, t_F | - | - | 25.0 | ns | Pin E |
| Address Setup Time | t_{SP1} | 30.0 | - | - | ns | Pins: RS, R/W, E |
| Address Hold Time | t_{HD1} | 10.0 | - | - | ns | Pins: RS, R/W, E |
| Data Setup Time | t_{SP2} | 40.0 | - | - | ns | Pins: DB7 - 0 |
| Data Hold Time | t_{HD2} | 10.0 | - | - | ns | Pins: DB7 - 0 |

Read mode

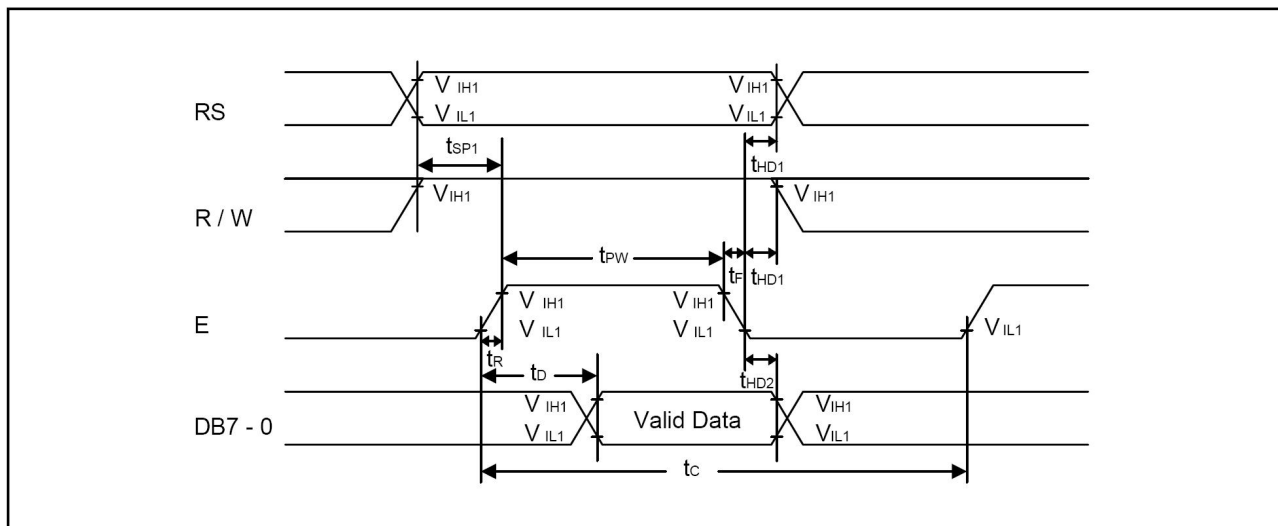

| Characteristics | Symbol | Limit | | | Unit | Test Condition |
|------------------------|------------|-------|------|-------|------|-----------------|
| | | Min. | Typ. | Max. | | |
| E Cycle Time | t_c | 400.0 | - | - | ns | Pin E |
| E Pulse Width | t_w | 150.0 | - | - | ns | Pin E |
| E Rise/Fall Time | t_R, t_F | - | - | 25.0 | ns | Pin E |
| Address Setup Time | t_{SP1} | 30.0 | - | - | ns | Pins: RS, R/W,E |
| Address Hold Time | t_{HD1} | 10.0 | - | - | ns | Pins: RS, R/W,E |
| Data Output Delay Time | t_D | - | - | 100.0 | ns | Pins: DB7 - 0 |
| Data hold time | t_{HD2} | 20.0 | - | - | ns | Pin DB7 - 0 |

2.4 Instruction Table

◆ Display Control Instruction

| Instruction | Instruction Code | | | | | | | | | | Description | Execution time ($F_{osc} = 270KHz$) |
|------------------------------------|------------------|----|-----|-----|-----|-----|-----|-----|-----|-----|--|--|
| | RS | RW | DB7 | DB6 | DB5 | DB4 | DB3 | DB2 | DB1 | DB0 | | |
| Clear Display | 0 | 0 | 0 | 0 | 0 | 0 | 0 | 0 | 0 | 1 | Write "20H" to DDRAM and set DDRAM address to "00H" from AC | 1.52ms |
| Return Home | 0 | 0 | 0 | 0 | 0 | 0 | 0 | 0 | 1 | - | Set DDRAM address to "00H" from AC and return cursor to its original position if shifted. The contents of DDRAM are not changed. | 1.52ms |
| Entry Mode Set | 0 | 0 | 0 | 0 | 0 | 0 | 0 | 1 | I/D | S | Assign cursor moving direction and enable the shift of entire display | 38 μ s |
| Display ON/OFF Control | 0 | 0 | 0 | 0 | 0 | 0 | 1 | D | C | B | Set display(D), cursor(C), and blinking of cursor(B) on/off control bit. | 38 μ s |
| Cursor or Display Shift | 0 | 0 | 0 | 0 | 0 | 1 | S/C | R/L | - | - | Set cursor moving and display shift control bit, and the direction, without changing of DDRAM data. | 38 μ s |
| Function Set | 0 | 0 | 0 | 0 | 1 | DL | N | F | - | - | Set interface data length (DL: 8-bit/4-bit), numbers of display line (N: 2-line/1-line) and, display font type (F: 5x10 dots/5x8 dots) | 38 μ s |
| Set CGRAM Address | 0 | 0 | 0 | 1 | AC5 | AC4 | AC3 | AC2 | AC1 | AC0 | Set CGRAM address in address counter. | 38 μ s |
| Set DDRAM Address | 0 | 0 | 1 | AC6 | AC5 | AC4 | AC3 | AC2 | AC1 | AC0 | Set DDRAM address in counter | 38 μ s |
| Read Busy Flag and Address Counter | 0 | 1 | BF | AC6 | AC5 | AC4 | AC3 | AC2 | AC1 | AC0 | Whether during internal operation or not can be known by reading BF. The contents of address counter can also be read. | |
| Write Data to RAM | 1 | 0 | D7 | D6 | D5 | D4 | D3 | D2 | D1 | D0 | Write data into internal RAM (DDRAM/CGRAM). | 38 μ s |
| Read Data from RAM | 1 | 1 | D7 | D6 | D5 | D4 | D3 | D2 | D1 | D0 | Read data from internal RAM (DDRAM/CGRAM). | 38 μ s |

* "-": don't care

2.5 Character Generator ROM

NO.7066-0A

| <small>b7-b4</small> | <small>b3-b0</small> | 0000 | 0001 | 0010 | 0011 | 0100 | 0101 | 0110 | 0111 | 1000 | 1001 | 1010 | 1011 | 1100 | 1101 | 1110 | 1111 |
|----------------------|----------------------|------|------|------|------|------|------|------|------|------|------|------|------|------|------|------|---|
| 0000 | CG RAM (1) | | | 0 | a | P | \ | P | | | | 一 | 夕 | ミ | ε | ρ | |
| 0001 | (2) | | ! | 1 | A | Q | a | 9 | | | | 。 | ア | チ | △ | ā | q |
| 0010 | (3) | | " | 2 | B | R | b | r | | | | 「 | イ | ツ | × | ρ | θ |
| 0011 | (4) | | # | 3 | C | S | c | s | | | | 」 | ウ | テ | ε | ε | ※ |
| 0100 | (5) | | \$ | 4 | D | T | d | t | | | | 、 | エ | ト | ト | μ | Ω |
| 0101 | (6) | | % | 5 | E | U | e | u | | | | ・ | オ | カ | ユ | ε | Ω |
| 0110 | (7) | | & | 6 | F | V | f | v | | | | ヲ | カ | ニ | ヨ | ρ | Σ |
| 0111 | (8) | | ^ | 7 | G | W | g | w | | | | フ | キ | ヌ | ラ | g | π |
| 1000 | (1) | | (| 8 | H | X | h | x | | | | イ | ウ | ※ | リ | γ | × |
| 1001 | (2) | |) | 9 | I | Y | i | y | | | | ウ | ケ | ル | ル | ” | γ |
| 1010 | (3) | | * | : | J | Z | j | z | | | | エ | コ | ン | レ | j | 〒 |
| 1011 | (4) | | + | ; | K | l | k | l | | | | ※ | サ | ヒ | ロ | ° | 〒 |
| 1100 | (5) | | , | < | L | ≠ | l | l | | | | ホ | シ | フ | フ | φ | 〒 |
| 1101 | (6) | | - | = | M | l | m | l | | | | ユ | ヌ | ハ | シ | ε | ÷ |
| 1110 | (7) | | . | > | N | ^ | n | + | | | | ヨ | セ | ホ | ° | 〒 | |
| 1111 | (8) | | / | ? | O | _ | o | + | | | | シ | リ | ヌ | ” | ○ |  |

2.6 Inspection Specification

- ◆ Inspection Standard : MIL-STD-105E Table Normal Inspection Single Sampling Level II .
- ◆ Equipment : Gauge、MIL-STD、Powertip Tester、Sample
- ◆ Defect Level : Major Defect AQL 0.4; Minor Defect AQL 1.5 .
- ◆ OUT Going Defect Level : Sampling .
- ◆ Manner of appearance test :
 - (1). The test be under 40W×2 fluorescent light ' and distance of view must be at 30 cm.
 - (2). The test direction is base on about around 45° of vertical line. (Fig. 1)
 - (3). Definition of area . (Fig. 2)

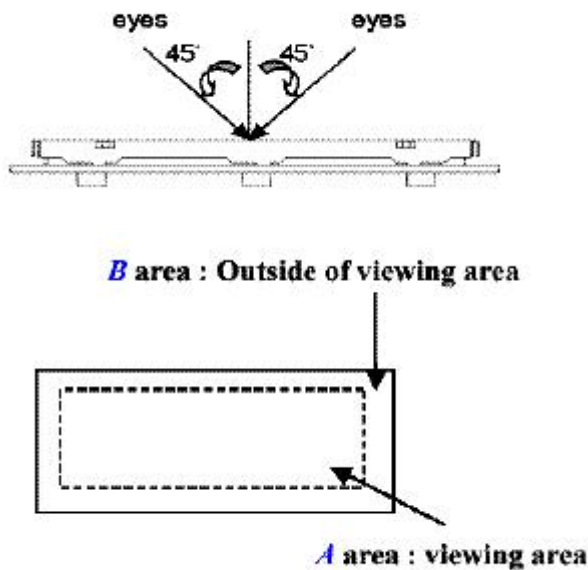



◆ Specification:

| NO | Item | Criterion | level |
|----|---|---|-------|
| 01 | Product condition | 1.1 The part number is inconsistent with work order of Production. | Major |
| | | 1.2 Mixed production types. | Major |
| | | 1.3 Assembled in inverse direction. | Major |
| 02 | Quantity | 2.1 The quantity is inconsistent with work order of production. | Major |
| 03 | Outline dimension | 3.1 Product dimension and structure must conform to Structure diagram. | Major |
| 04 | Electrical Testing | 4.1 Missing line character、 dot and icon. | Major |
| | | 4.2 No function or no display. | Major |
| | | 4.3 Output data is error. | Major |
| | | 4.4 LCD viewing angle defect. | Major |
| | | 4.5 Current consumption exceeds product specifications. | Major |
| 05 | Black or white dot、 scratch、 contamination Round type | 5.1 Round type: 5.1.1 display only : • White and black spots on display $\leq 0.25\text{mm}$, no more than Four white or black spots present. • Densely spaced : NO more than two spots or lines within | Minor |

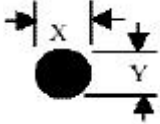
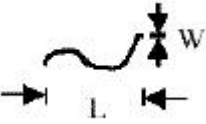

| | | | |
|--|--|-----|--|
| | | 3mm | |
|--|--|-----|--|

◆ Specification :

| NO | Item | Criterion | level |
|----|---|---|-------|
| 05 | <p>Black or white dot、scratch、contamination Round type</p>  <p>$\Phi = (x+y)/2$</p>  | <p>5.1.2 Nom-display :</p> <p>Dimension (diameter : Φ) Acceptance(Q'ty)</p> <p>$\Phi \leq 0.20\text{mm}$ Accept no dense</p> <p>$0.10\text{mm} < \Phi \leq 0.20\text{mm}$ 3</p> <p>$0.20\text{mm} < \Phi \leq 0.25\text{mm}$ 2</p> <p>Total 4</p> <p>5.1.3 Line type: Dimension (diameter : Φ) Acceptance (Q'ty)</p> <p>Length width A area B area</p> <p>---</p> <p>$w \leq 0.03\text{mm}$ Accept no dense Don't count</p> <p>$L \leq 3.0\text{mm}$ $0.03\text{mm} < \Phi \leq 0.05\text{mm}$</p> <p>Don't count 4</p> <p>$L \leq 2.5\text{mm}$ $0.05\text{mm} < \Phi \leq 0.075\text{mm}$</p> <p>Don't count</p> <p>---</p> <p>$w > 0.075\text{mm}$ As round type</p> | Minor |

| | | | |
|----|-----------------------|---|-------|
| 06 | Polarizer Bubble | <p>Dimension (diameter : Φ)</p> <p>A area</p> <p>Acceptance(Q'ty)</p> <p>B area $\Phi \leq 0.20\text{mm}$ Accept no dense Don't count</p> <p>$0.20\text{mm} < \Phi \leq 0.50\text{mm}$ 3 Don't count</p> <p>$0.50\text{mm} < \Phi \leq 1.00\text{mm}$ 2 Don't count</p> <p>$\Phi > 1.00\text{mm}$ 0 Don't count</p> <p>Total quantity 4 Don't count</p> | Minor |
| 07 | The crack of glass | <p>● Glass Crack: 7.1 Crack on the circuit of electrode terminal :</p>  <p>X Y Z</p> <p>Front $X \leq 1/5 a$ $Y \leq 1/2 D$ $Z \leq t$</p> <p>Back</p> <p>Neglect</p> | Minor |

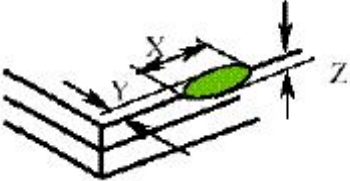
◆ Specification :

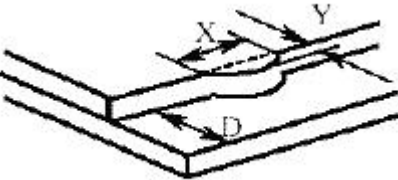
| NO | Item | Criterion | Level |
|----|---|--|-------|
| 07 | <p>The crack of glass</p> <p>X: The length of Crack</p> <p>Y: The width of crack</p> <p>Z: The thickness of crack</p> <p>D: terminal length</p> <p>T: The thickness of glass</p> <p>A : The length of glass</p> | <p>● Glass Crack:</p> <p>7.2 General glass crack and corner edge:</p> <p>7.2.1</p>  <p>X Y Z Neglect Out A area Neglect</p> <p>7.2.2</p>  <p>X Y Z Neglect Out A area Neglect</p> | Minor |
| | | <p>7.3 Glass remain:</p>  <p>X Y Neglect $\leq 1/3 d$</p> | Minor |

◆Specification :

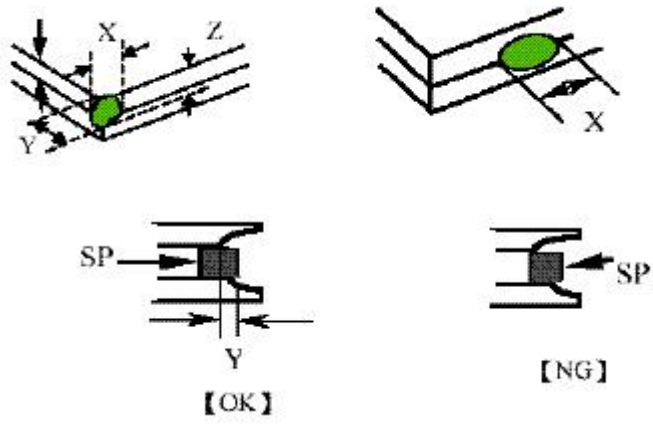
| NO | Item | Criterion | Level |
|----|---|--|-------|
| 07 | <p>The crack of glass</p> <p>X: The length of Crack</p> <p>Y: The width of crack</p> <p>Z: The thickness of crack</p> <p>D: terminal length</p> <p>T: The thickness of glass</p> <p>A : The length of glass</p> | <p>7.4 Corner crack and medial crack:</p>  <p style="text-align: center;"> X Y Z $\cong 1/5a$ Crack can't enter viewing area $\cong 1/2t$ $\cong 1/5a$ Crack can't exceed the half of width of SP width of SP $1/2t < Z \cong 2t$ </p> | Minor |
| 08 | Backlight elements | <p>8.1 Backlight can't work normally.</p> <p>8.2 Backlight doesn't light or color is wrong.</p> <p>8.3 Illumination source flickers when lit.</p> | Major |
| 09 | General appearance | <p>9.1 pin type must match type in specification sheet</p> <p>9.2 No short circuits in components on PCB or FPC</p> <p>9.3 Product packaging must the same as specified on packaging specification sheet.</p> <p>9.4 The folding and peeled off in polarizer are not acceptable</p> <p>9.5 The PCB or FPC between B/L assembled distance (PCB or FPC) is $\cong 1.5\text{mm}$</p> | Major |