



PRODUCT SPECIFICATIONS

For Customer: _____ : APPROVAL FOR SPECIFICATION

Customer Model No. _____ : APPROVAL FOR SAMPLE

Module No.: LW043DURN3-02 Version: V1.1 Date : 2017-06-14

Table of Contents

No.	Item	Page
1	Cover Sheet (Table of Contents)	1
2	Revision Record	2
3	General Specifications	3
4	Outline Drawing	4
5	Operation Specifications	7
6	Interface Timing Chart	9
7	Optical Characteristics	13
8	Reliability Test Items and Criteria	16
9	Precautions for Use of LCD Modules	17
10	P/N Coding System	18

For Customer's Acceptance:

Approved By	Comment

PREPARED	CHECKED	VERIFIED BY QA DEPT	VERIFIED BY R&D DEPT
Tony	Steven		



3. General Specifications

LW043DURN3-02 is a TFT-LCD module. It is composed of a TFT-LCD panel, driver IC, FPC and backlight unit. The 4.3 inch display area contains 480 x 272 pixels and can display up to 16.7M colors. This product accords with RoHS environmental criterion

Item	Contents	Unit	Note
LCD Type	TFT	-	
Display Mode	TN Normally White Transmissive		
Gray Scale Inversion Direction	6:00	O'clock	
Best Viewing Direction	12:00	O'clock	
Surface treatment	HC	-	
Drive IC	OTA5180A		
Power Supply for LCD	3.3	V	
Interface	24Bits-RGB	-	
Outline Dimensions	105.50*67.20*3.05	mm	
Active Area(W×H)	95.04*53.86	mm	
Pixel Pitch(W×H)	0.198*0.198	mm	
Number of Dots	480(RGB)×272	dots	
Backlight	10-LEDs (white)	pcs	
Luminance for LCM	400	Cd/m2	
Weight	-	G	
Touch Panel	No Touch Panel	-	
Operating temperature	-20~+70	°C	
Storage temperature	-30~+80	°C	



4.1 Interface Signals

FPC Connector is used for the module electronics interface. The recommended model is FH12A-40S-0.5SH manufactured by Hirose.

Pin No.	Symbol	Function	Remark
1	LEDK	LED Cathode	
2	LEDA	LED Anode	
3	GND	Ground	
4	VDD	Power for digital circuit	
5	R0	Red Date	
6	R1	Red Date	
7	R2	Red Date	
8	R3	Red Date	
9	R4	Red Date	
10	R5	Red Date	
11	R6	Red Date	
12	R7	Red Date	
13	G0	Green Date	
14	G1	Green Date	
15	G2	Green Date	
16	G3	Green Date	
17	G4	Green Date	
18	G5	Green Date	
19	G6	Green Date	
20	G7	Green Date	
21	B0	Blue Date	
22	B1	Blue Date	
23	B2	Blue Date	
24	B3	Blue Date	
25	B4	Blue Date	
26	B5	Blue Date	
27	B6	Blue Date	
28	B7	Blue Date	
29	GND	Ground	
30	DCLK	Clock Input	
31	DISP	Display ON/OFF control	
32	HSYNC	Horizontal Sync signal	
33	VSYNC	Vrtical Sync signal	
34	DE	Date Enable	
35	NC	No connection	



36	GND	Ground	
37	NC	No connection	
38	NC	No connection	
39	NC	No connection	
40	NC	No connection	

LCD World Limited



5、 Operation Specifications

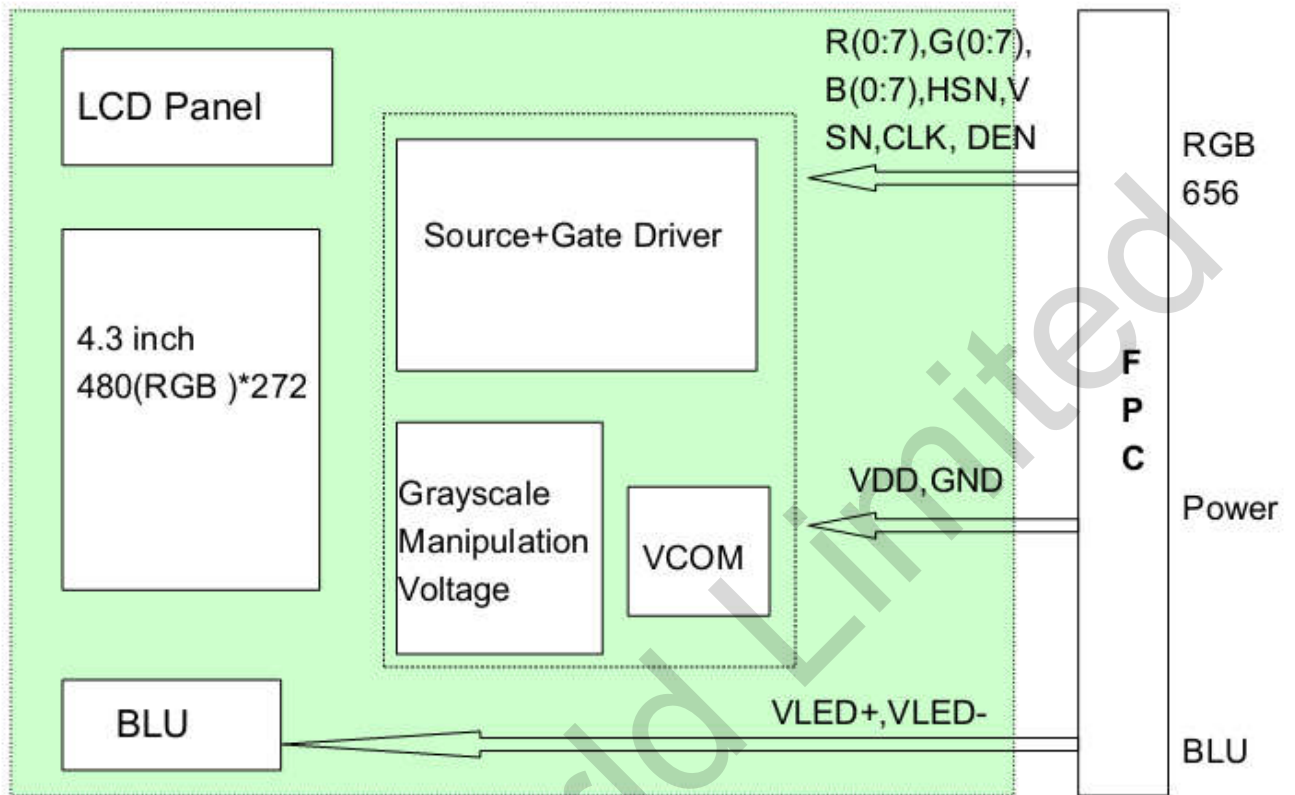

5.1 Absolute Maximum Ratings(Ta=25°C)

Item	Symbol	Min.	Max.	Unit	Note
Power Supply Voltage	VDD	-0.3	4.5	V	
Power Supply Voltage for LCD	Vop	-0.3	VDD+0.3	V	
Operating Temperature	Top	-20	+70	°C	
Storage Temperature	Tst	-30	+80	°C	

Notes:

1. If the module is above these absolute maximum ratings. It may become permanently damaged. Using the module within the following electrical characteristic conditions are also exceeded, the module will malfunction and cause poor reliability.
2. VDD >VSS must be maintained.



5.2 Electrical characteristics (Ta=25°C)

Parameter	Symbol	Condition	Min	Typ	Max	Unit	Note
Logic Power supply	VDD	Ta=25°C	-	3.3	-	V	
Input voltage	'H'	V _{IH}	-	0.7xV _{DD}	-	V _{DD}	V
	'L'	V _{IL}	-	V _{SS}	-	0.3V _{DD}	V
Output Voltage	'H'	V _{OH}	-	0.8xV _{DD}	-	V _{DD}	V
	'L'	V _{OL}	-	-	-	0.2V _{DD}	V
Current Consumption	Black Mode(60HZ)		-	74	-	nW	
	Stand-by		-	50	-	uW	

5.4 LED backlight specification(Ta=25°C, 60%RH±5%)

Item	Symbol	Values			Unit	Remark
		Min.	Typ.	Max.		
LED Current	I _{LED}		40		mA	Total LED
Forward Voltage	V _F	-	16		V	I _F =20mA
Power Dissipation	P _d	-	640		mW	Total LED
Backlight Lifetime		25000(Min)			Hour	

Note: Backlight lifetime means brightness goes down to 50% initial brightness;
 The lifetime of LED will be reduced if LED is driven by high current, high ambient temperature and humidity conditions;

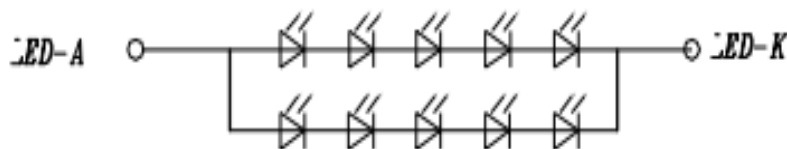



6 Interface Timing

6.1 Parallel RGB Data Format

Item	Symbol	Min.	Typ.	Max.	Unit		
DCLK Frequency	Fclk	5	9	12	MHz		
DCLK Period	Tclk	83	110	200	ns		
Hsync	Period Time	Th	490	531	605	DCLK	
	Display Period	Thdisp		480		DCLK	
	Back Porch	Thbp	8	43		DCLK	By H_BLANKING setting
	Front Porch	Thfp	2	8		DCLK	
	Pulse Width	Thw	1			DCLK	
Vsync	Period Time	Tv	275	288	335	H	
	Display Period	Tvdisp		272		H	
	Back Porch	Tvbp	2	12		H	By V_BLANKING setting
	Front Porch	Tvfp	1	4		H	
	Pulse Width	Tvw	1	10		H	

6.2 SYNC Mode Timing Diagram

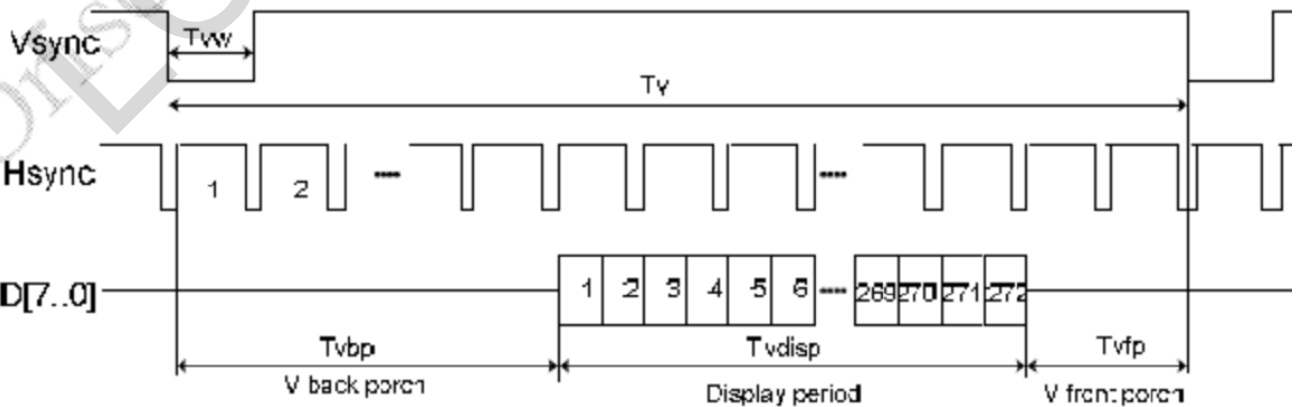
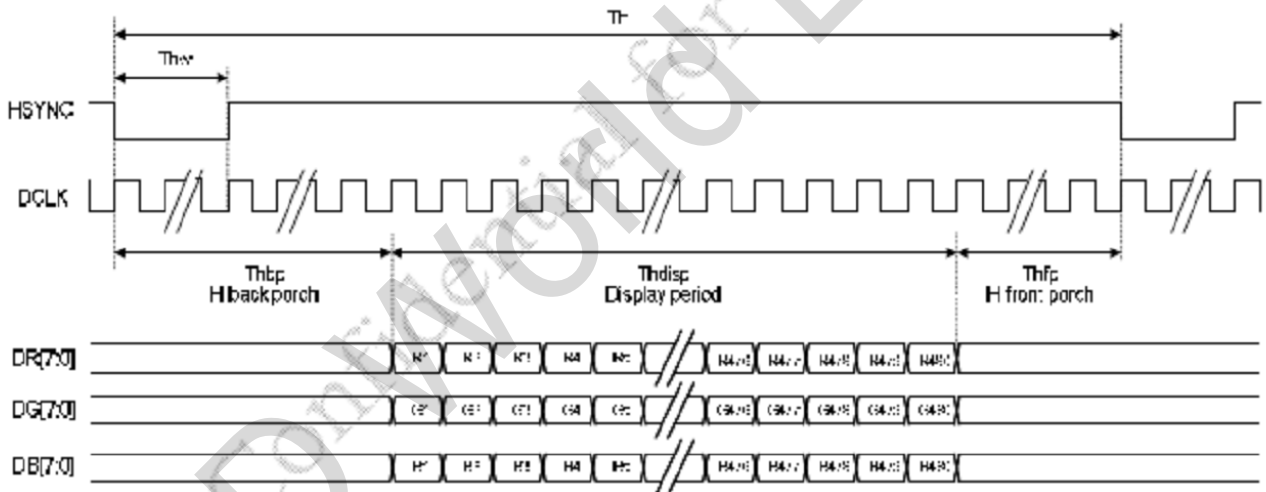



6.3 SYNC-DE Mode Timing Diagram

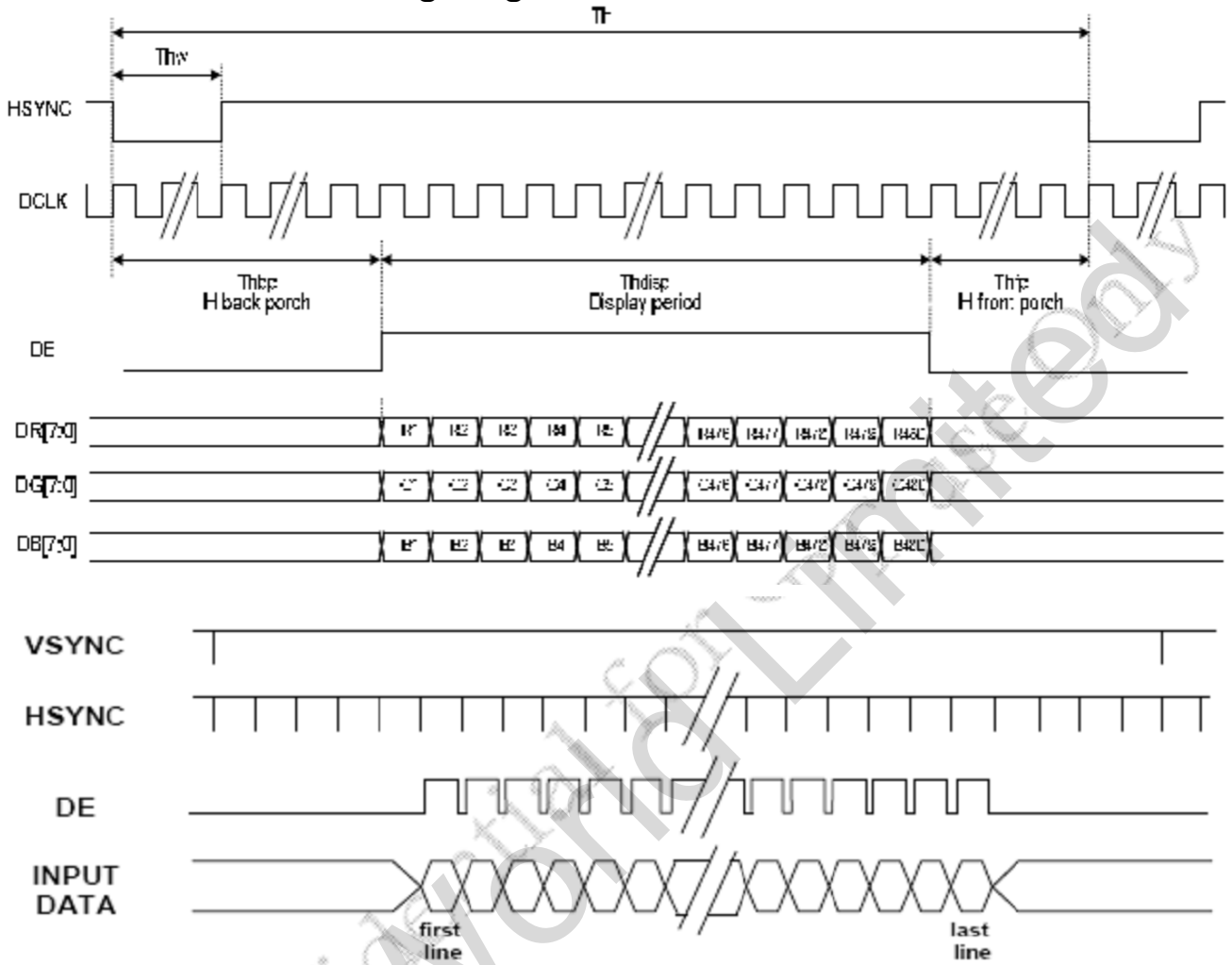



6.4 Clock and Date Input Timing Diagram

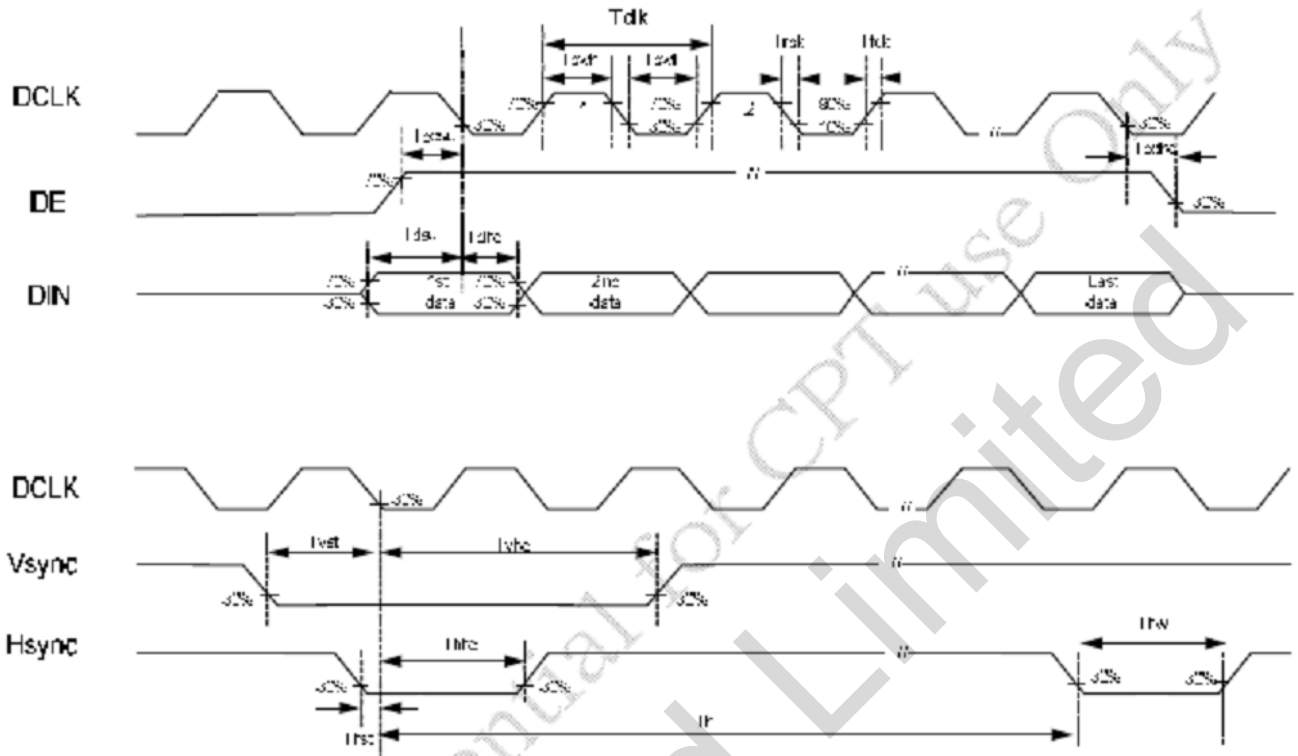



6.5 Power ON/OFF Sequence

Power ON Sequence

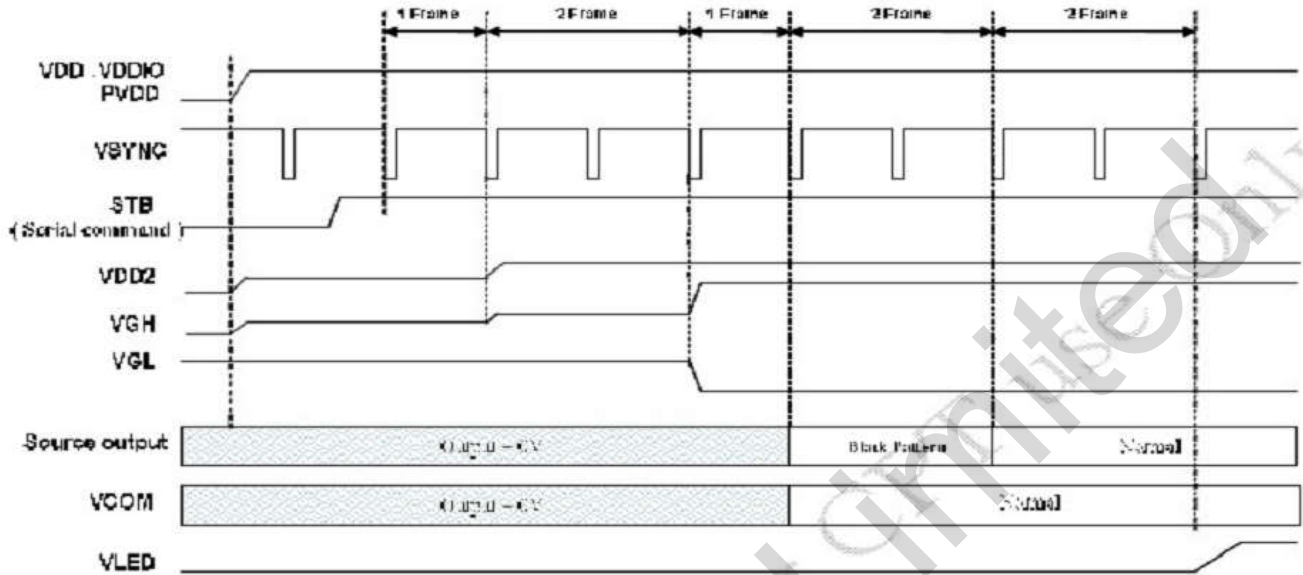

Power OFF Sequence

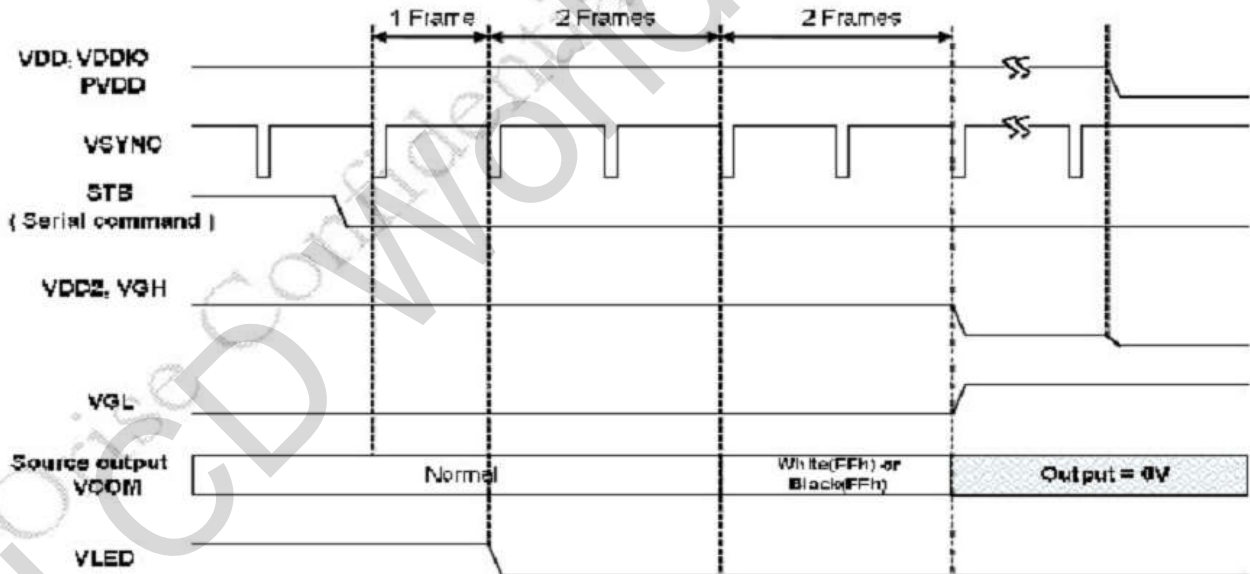



7. Optical Characteristics

Item	Symbol	Condition	Min.	Typ.	Max.	Unit	Note
Brightness	Bp	$\theta=0^\circ$ $\Phi=0^\circ$	-	400	-	Cd/m ²	1
Uniformity	Δ Bp		75	80	-	%	1,2
Viewing Angle	3:00	Cr \geq 10	-	65	-	Deg	3
	6:00		-	65	-		
	9:00		-	65	-		
	12:00		-	45	-		
Contrast Ratio	Cr		250	350	-	-	4
Response Time	T _r	$\theta=0^\circ$ $\Phi=0^\circ$	-	10	20	ms	5
	T _f		-	15	30	ms	
Color of CIE Coordinate	W	x	0.260	0.310	0.360	-	1,6
		y	0.280	0.330	0.380	-	
	R	x	-	-	-	-	
		y	-	-	-	-	
	G	x	-	-	-	-	
		y	-	-	-	-	
	B	x	-	-	-	-	
		y	-	-	-	-	
NTSC Ratio	S			50	-	%	

Note: The parameter is slightly changed by temperature, driving voltage and material

Note 1: The data are measured after LEDs are turned on for 5 minutes. LCM displays full white. The brightness is the average value of 9 measured spots.

Measuring condition:

- Measuring surroundings: Dark room.
- Measuring temperature: Ta=25°C.
- Adjust operating voltage to get optimum contrast at the center of the display.

Measured value at the center point of LCD panel after more than 5 minutes while backlight turning on.

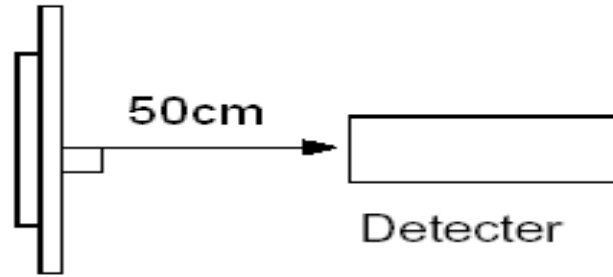

Note 2: The luminance uniformity is calculated by using following formula.

$$\Delta Bp = Bp (\text{Min.}) / Bp (\text{Max.}) \times 100 (\%)$$

Bp (Max.) = Maximum brightness in 9 measured spots

Bp (Min.) = Minimum brightness in 9 measured spots.

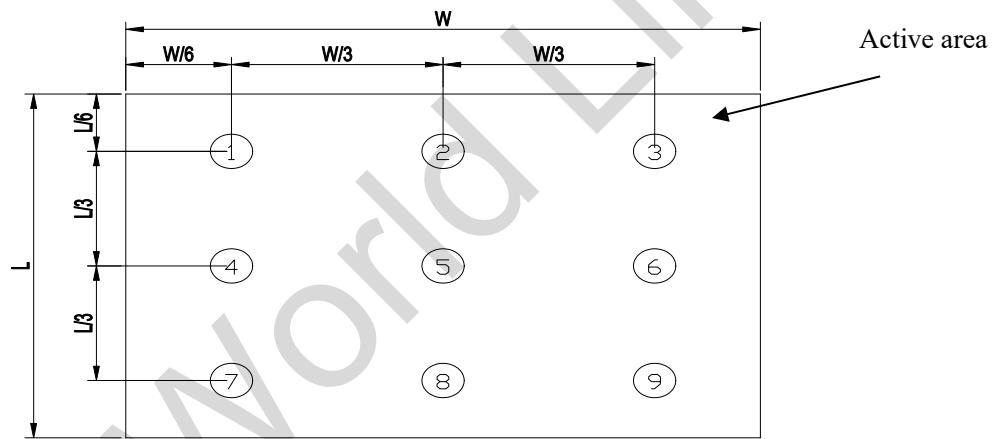

Note 3: The definition of viewing angle:

Refer to the graph below marked by θ and ϕ

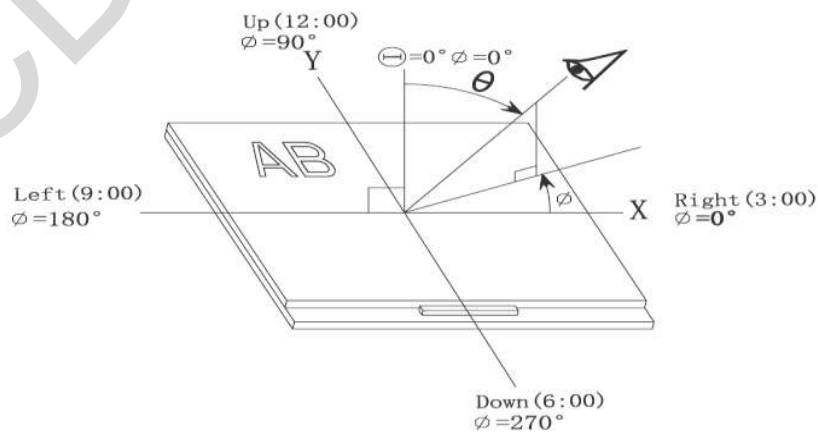



Note 4: Definition of contrast ratio.

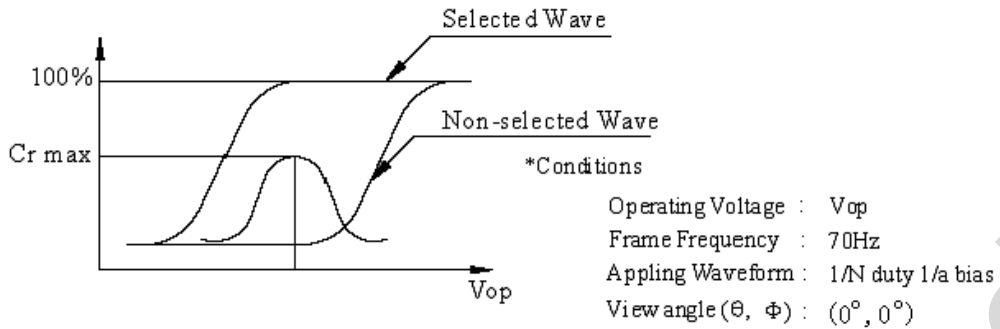

$$\text{Contrast ratio (Cr)} = \frac{\text{Brightness of selected dots}}{\text{Brightness of non-selected dots}}$$

Note 5: Definition of Response time.

The output signals of photo detector are measured when the input signals are changed from “black” to “white”(falling time) and from “white” to “black”(rising time), respectively. The response time is defined as the time interval between the 10% and 90% of amplitudes. Refer to figure as below.

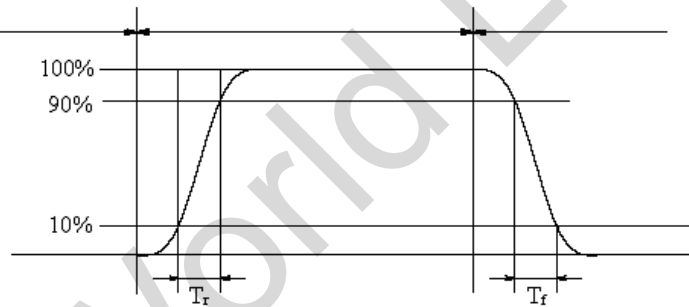

The definition of response time

Note 6: Definition of Color of CIE Coordinate and NTSC Ratio.

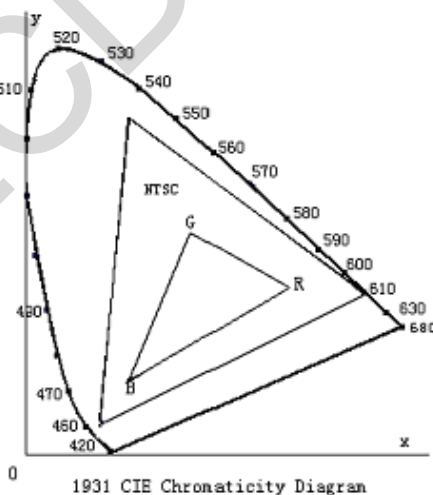

Color gamut:

$$S = \frac{\text{area of RGB triangle}}{\text{area of NTSC triangle}} \times 100\%$$



8. Reliability Test Items and Criteria

No	Test Item	Test condition	Criterion
1	Low Temperature Operating Life test	-20°C, 96HR	Note
2	Thermal Humidity Operating Life test	40°C, 90%RH, 96HR	
3	Temperature Cycle ON/OFF test	-20°C ↔ 70°C, ON/OFF, 20CYC	
4	High Temperature Storage test	80°C, 96HR	
5	Low Temperature Storage test	- 30°C, 96HR	
6	Thermal Shock Resistance	The sample should be allowed to stand the following 5 cycles of operation: TSTL for 30 minutes -> normal temperature for 5 minutes -> TSTH for 30 minutes -> normal temperature for 5 minutes, as one cycle, then taking it out and drying it at normal temperature, and allowing it stand for 24 hours	
7	Box Drop Test	1 Corner 3 Edges 6 faces, 66cm(MEDIUM BOX)	



9. Precautions for Use of LCD Modules

9.1 Handling Precautions

- 9.1.1 The display panel is made of glass. Do not subject it to a mechanical shock by dropping it from a high place, etc.
- 9.1.2 If the display panel is damaged and the liquid crystal substance inside it leaks out, be sure not to get any in your mouth, if the substance comes into contact with your skin or clothes, promptly wash it off using soap and water.
- 9.1.3 Do not apply excessive force to the display surface or the adjoining areas since this may cause the color tone to vary.
- 9.1.4 The polarizer covering the display surface of the LCD module is soft and easily scratched. Handle this polarizer carefully.
- 9.1.5 If the display surface is contaminated, breathe on the surface and gently wipe it with a soft dry cloth. If still not completely clear, moisten cloth with one of the following solvents:
 - Isopropyl alcohol
 - Ethyl alcoholSolvents other than those mentioned above may damage the polarizer. Especially, do not use the following:
 - Water
 - Ketone
 - Aromatic solvents
- 9.1.6 Do not attempt to disassemble the LCD Module.
- 9.1.7 If the logic circuit power is off, do not apply the input signals.
- 9.1.8 To prevent destruction of the elements by static electricity, be careful to maintain an optimum work environment.
 - a. Be sure to ground the body when handling the LCD Modules.
 - b. Tools required for assembly, such as soldering irons, must be properly ground.
 - c. To reduce the amount of static electricity generated, do not conduct assembly and other work under dry conditions.
 - d. The LCD Module is coated with a film to protect the display surface. Be care when peeling off this protective film since static electricity may be generated.

9.2 Storage precautions

- 9.2.1 When storing the LCD modules, avoid exposure to direct sunlight or to the light of fluorescent lamps.
- 9.2.2 The LCD modules should be stored under the storage temperature range. If the LCD modules will be stored for a long time, the recommend condition is:
 - Temperature : 0°C ~ 40°C
 - Relatively humidity: ≤80%
- 9.2.3 The LCD modules should be stored in the room without acid, alkali and harmful gas.

- 9.3 The LCD modules should be no falling and violent shocking during transportation, and also should avoid excessive press, water, damp and sunshine.



10. LCDW P/N Coding System

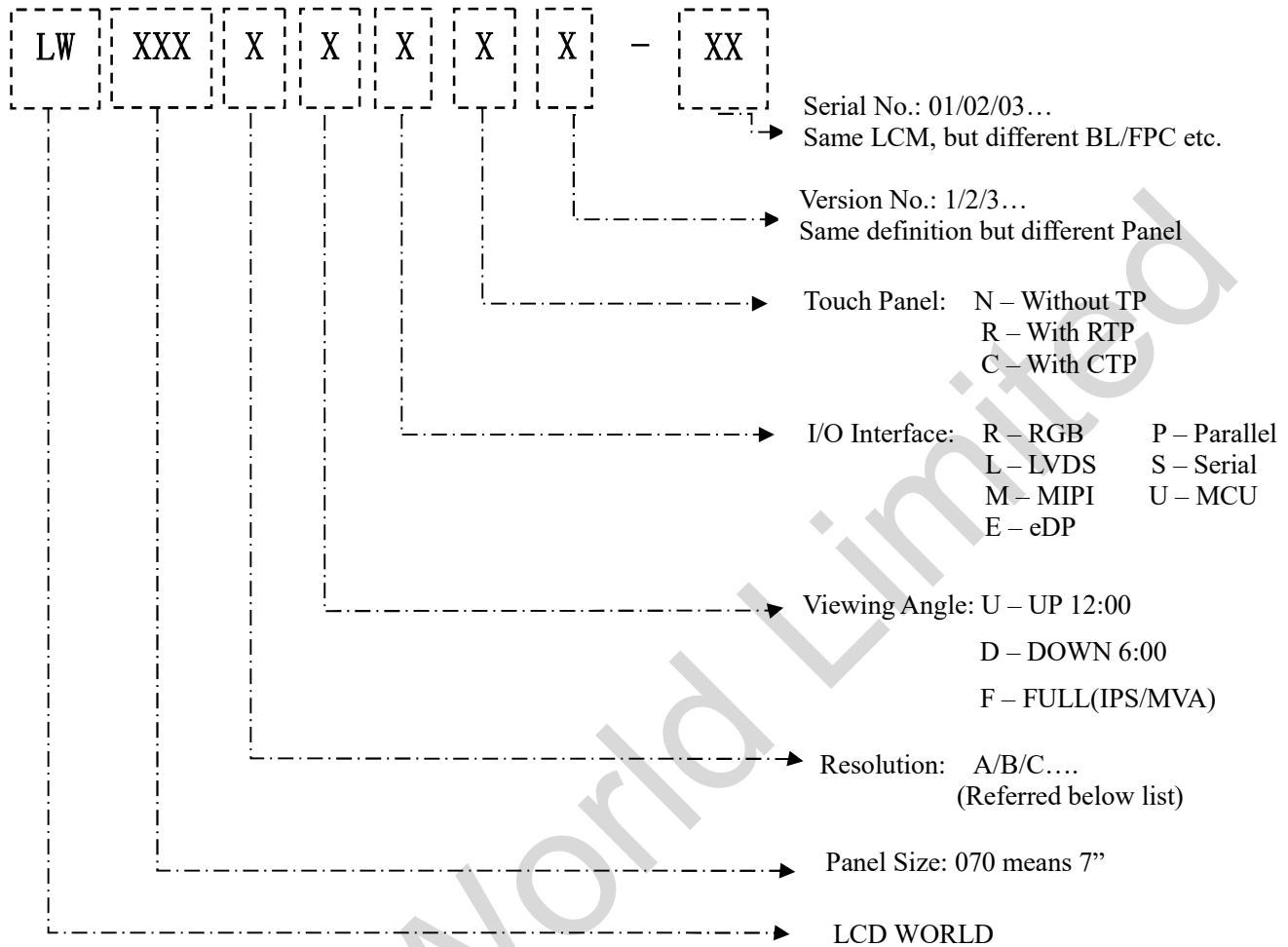

	Resolution	Code
QQVGA	128*160	A
QCIF	176*220	B
QVGA	320*240	C
WQVGA	272*480	D
HVGA	320*480	E
VGA	480*640	F
WVGA	800*480	G
SVGA	800*600	H
WSVGA	1024*600	J
XGA	1024*768	K
HD	1280*720	L
WXGA	1280*800	M
SXGA	1280*960	N
WSXGA	1680*1024	P
UGA	1600*1200	Q
FHD	1920*1080	R
WUXGA	1920*1200	S

END