



深圳市一众显示科技有限公司

SHEN ZHEN TEAM SOURCE DISPLAY TECH. CO, LTD.

# TFT-LCD Module Specification

**Module NO.:** TSM043WQBS-37C

**Version:** V1.0

APPROVAL FOR SPECIFICATION

APPROVAL FOR SAMPLE

<b>For Customer' s Acceptance:</b>	
<b>Approved by</b>	<b>Comment</b>

<b>Team Source Display:</b>		
<b>Presented by</b>	<b>Reviewed by</b>	<b>Organized by</b>

<b>Version No.</b>	<b>Date</b>	<b>Content</b>	<b>Remark</b>
V1.0	2018-9-21	Initial Release	

**CONTENTS**

**1 GENERAL CHARACTERISTICS..... - 3 -**

**2 PRODUCT DRAWINGS..... - 4 -**

**3 INTERFACE DESCRIPTION..... - 5 -**

    3.1 LCM INTERFACE DESCRIPTION..... - 5 -

    3.2 CTP INTERFACE DESCRIPTION..... - 6 -

**4 PARALLEL 8080-SERIES INTERFACE TIMING..... - 7 -**

**5 LCD RGB TIMING CHARACTERISTICS..... - 8 -**

**6 INPUT PIXEL DATA FORMAT..... - 9 -**

**7 COMMAND TABLE..... - 10 -**

**8 ABSOLUTE MAXIMUM RATINGS..... - 13 -**

**9 ELECTRICAL CHARACTERISTICS..... - 13 -**

**10 BACKLIGHT CHARACTERISTICS..... - 13 -**

**11 LCD OPTICAL SPECIFICATIONS..... - 14 -**

**12 CAPACITIVE TOUCH PANEL SPECIFICATIONS..... - 16 -**

    12.1 MECHANICAL CHARACTERISTICS..... - 16 -

    12.2 ELECTRICAL CHARACTERISTICS..... - 16 -

    12.3 INTERFACE TIMING CHARACTERISTICS..... - 16 -

**13 RELIABILITY TEST..... - 17 -**

**14 SUGGESTIONS FOR USING LCD MODULES..... - 17 -**

    14.1 HANDLING OF LCM..... - 17 -

    14.2 STORAGE..... - 18 -

## 1 General Characteristics

ITEM	Specification	Unit
LCD Type	a-Si TFT, Transmissive, Normally white, TN	-
LCD Size	4.3	inch
Resolution (W x H)	480 x (RGB) × 272	pixel
LCM&CTP size	123.04(W) x 84.46(H) x 7.93(D)	mm
Active Area	95.04 (W) x 53.86 (H)	mm
Dot Pitch	0.153(H)x0.153(V)	mm
Viewing Direction	12 o'clock	-
Gray Scale Inversion Direction	6 o'clock	-
Color Depth	65K/262K/16.7M	-
Pixel Arrangement	RGB-stripe	-
Backlight Type	16 LEDs, 40mA	-
Surface Luminance	720min, 800typ	cd/m <sup>2</sup>
Surface Treatment	Clear, Hardness: 6H	-
Driver IC	SSD1963	-
Interface Type	MCU8/16bit	-
Input Voltage	3.3	V
With/Without TP	With CTP(FT5316DME)	-
Weight	TBD	g

**Note 1: RoHS compliant**

**Note 2: LCM weight tolerance: ± 5%.**



### 3 Interface description

#### 3.1 LCM interface description

PIN NO.	Symbol	description
1	GND	System Ground. (0V)
2	VCC	Power supply +5.0V
3	BL_EN	Backlight enable High, Backlight ON; Low, Backlight off.
4	RS	Data/Command select
5	WR	write strobe signal
6	RD	read strobe signal
7~22	DB0~DB15	MCU16-bit Data bus. Pins not used should be floating.
23-24	NC	No connect
25	CS	Chip select
26	RESET	Master synchronize reset
27-31	NC	No connect
32	DISP	Standby mode control. (Normally pull high) DISP="L", enter standby mode for power saving. Timing controller and source driver will turn off, all outputs are Hi-Z. DISP="H", normal operation.

### 3.2 CTP interface description

PIN NO.	Symbol	description
1-2	NC	No connect
3	RST	External Reset, Low is active
4	GND	Ground. (0V)
5	INT	Interrupt request to the host
6	SDA	I2C data input and output
7	SCL	I2C clock input
8-9	GND	Ground. (0V)
10	VDD	Power supply +3.3V

## 4 Parallel 8080-series Interface Timing

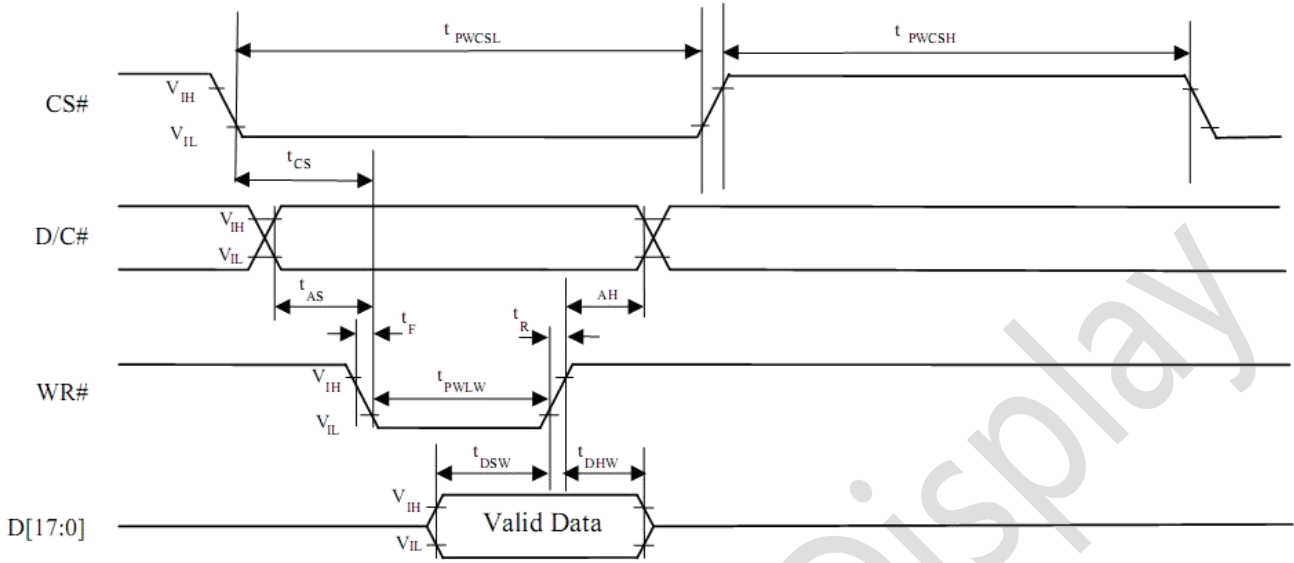

Parallel 8080-series Interface Timing Diagram (Write Cycle)

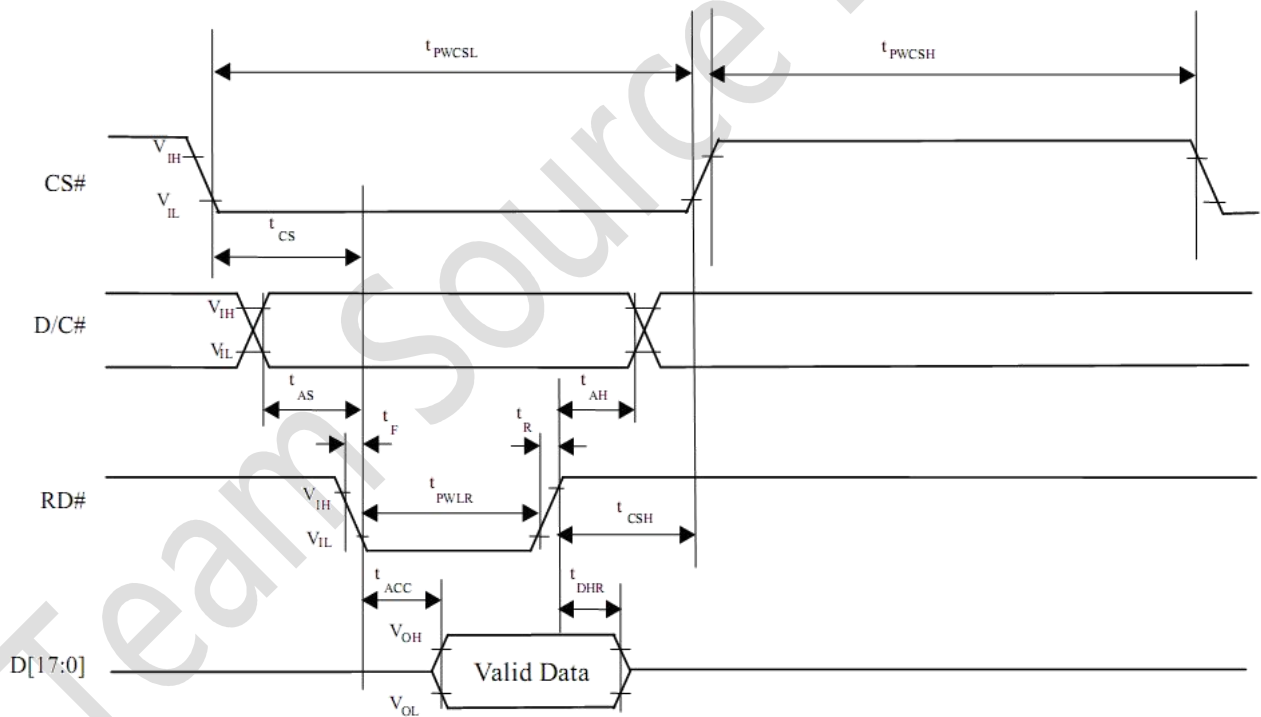

Parallel 8080-series Interface Timing Diagram (Read Cycle)

Symbol	Parameter	Min	Typ	Max	Unit
$f_{MCLK}$	System Clock Frequency*	1	-	110	MHz
$t_{MCLK}$	System Clock Period*	$1/f_{MCLK}$	-	-	ns
$t_{PWCSL}$	Control Pulse High Width	Write	13	$1.5 * t_{MCLK}$	ns
		Read	30	$3.5 * t_{MCLK}$	
$t_{PWCSH}$	Control Pulse Low Width	Write (next write cycle)	13	$1.5 * t_{MCLK}$	ns
		Write (next read cycle)	80	$9 * t_{MCLK}$	
		Read	80	$9 * t_{MCLK}$	
$t_{AS}$	Address Setup Time	1	-	-	ns
$t_{AH}$	Address Hold Time	2	-	-	ns
$t_{DSW}$	Write Data Setup Time	4	-	-	ns
$t_{DHW}$	Write Data Hold Time	1	-	-	ns
$t_{PWLW}$	Write Low Time	12	-	-	ns
$t_{DHR}$	Read Data Hold Time	1	-	-	ns
$t_{ACC}$	Access Time	32	-	-	ns
$t_{PWLR}$	Read Low Time	36	-	-	ns
$t_R$	Rise Time	-	-	0.5	ns
$t_F$	Fall Time	-	-	0.5	ns
$t_{CS}$	Chip select setup time	2	-	-	ns
$t_{CSH}$	Chip select hold time to read signal	3	-	-	ns

\* System Clock denotes external input clock (PLL-bypass) or internal generated clock (PLL-enabled)

## 5 LCD RGB Timing Characteristics

DE Mode Timing Diagram

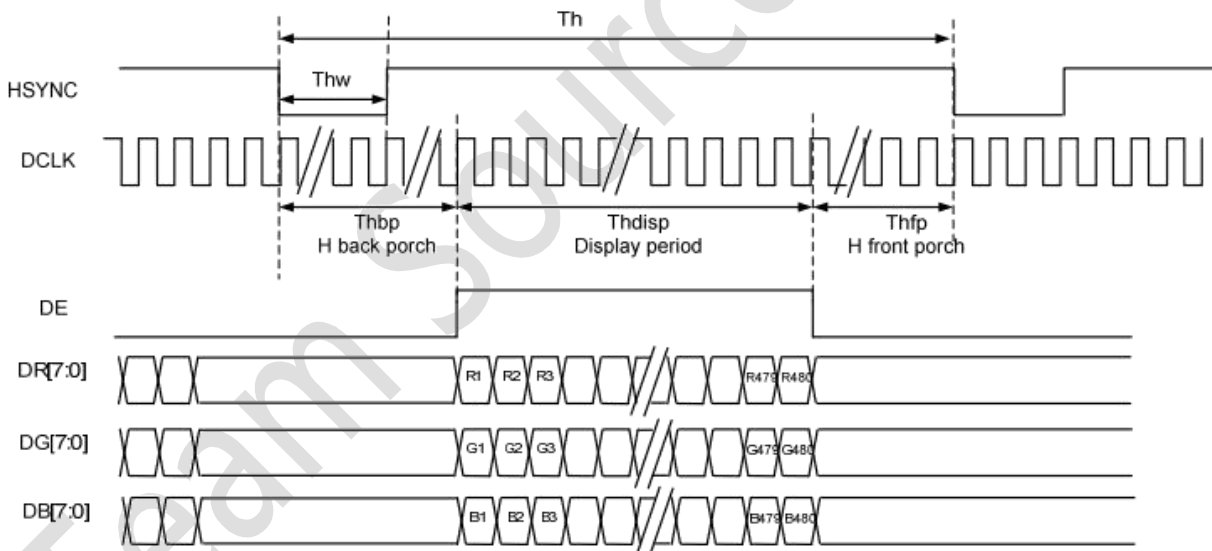

Horizontal Input Timing

Parameter	Symbol	min	Typ.	max	Unit
Horizontal display area	tHD	-	480	-	CLKIN
CLKIN frequency	$f_{clk}$	8	9	12	MHz
1 Horizontal line period	$T_h$	485	531	-	CLKIN
HSD pulse width	$T_{hw}$	2	4	-	
HSD back porch	$T_{hbp}$	3	43	-	
HSD front porch	$T_{hfp}$	2	8	-	



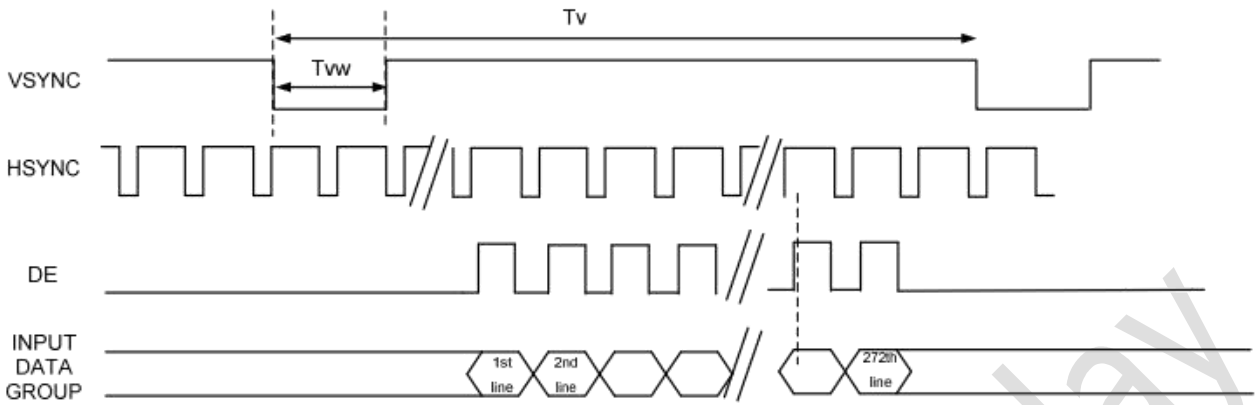

Vertical Input Timing

Parameter	Symbol	min	Typ.	max	Unit
Vertical display area	$t_{vD}$	-	272	-	HSD
VSD period time	$t_v$	276	292	-	
VSD pulse width	$T_{VPW}$	2	4	-	
VSD back porch	$t_{VBP}$	2	12	-	
VSD front porch	$t_{VFP}$	2	8	-	

## 6 Input Pixel Data Format

Interface	Cycle	D[23]	D[22]	D[21]	D[20]	D[19]	D[18]	D[17]	D[16]	D[15]	D[14]	D[13]	D[12]	D[11]	D[10]	D[9]	D[8]	D[7]	D[6]	D[5]	D[4]	D[3]	D[2]	D[1]	D[0]	
24 bits	1 <sup>st</sup>	R7	R6	R5	R4	R3	R2	R1	R0	G7	G6	G5	G4	G3	G2	G1	G0	B7	B6	B5	B4	B3	B2	B1	B0	
18 bits	1 <sup>st</sup>							R5	R4	R3	R2	R1	R0	G5	G4	G3	G2	G1	G0	B5	B4	B3	B2	B1	B0	
16 bits (565 format)	1 <sup>st</sup>									R5	R4	R3	R2	R1	G5	G4	G3	G2	G1	G0	B5	B4	B3	B2	B1	
16 bits	1 <sup>st</sup>									R7	R6	R5	R4	R3	R2	R1	R0	G7	G6	G5	G4	G3	G2	G1	G0	
	2 <sup>nd</sup>									B7	B6	B5	B4	B3	B2	B1	B0	R7	R6	R5	R4	R3	R2	R1	R0	
	3 <sup>rd</sup>									G7	G6	G5	G4	G3	G2	G1	G0	B7	B6	B5	B4	B3	B2	B1	B0	
12 bits	1 <sup>st</sup>																	R7	R6	R5	R4	R3	R2	R1	R0	
	2 <sup>nd</sup>																	G3	G2	G1	G0	B7	B6	B5	B0	
9 bits	1 <sup>st</sup>																	R5	R4	R3	R2	R1	R0	G5	G4	G3
	2 <sup>nd</sup>																		G2	G1	G0	B5	B4	B3	B2	B1
8 bits	1 <sup>st</sup>																									
	2 <sup>nd</sup>																									
	3 <sup>rd</sup>																									

\*note: The TSM043WQBS-37C module support 8-bit and 16-bit only.

## 7 Command Table

Hex Code	Command	Description
0x00	nop	No operation
0x01	soft_reset	Software Reset
0x0A	get_power_mode	Get the current power mode
0x0B	get_address_mode	Get the frame buffer to the display panel read order
0x0C	Reserved	Reserved
0x0D	get_display_mode	The SSD1963 returns the Display Image Mode.
0x0E	get_tear_effect_status	Get the Tear Effect status
0x0F	Reserved	Reserved
0x10	enter_sleep_mode	Turn off the panel. This command will pull low the GPIO0. If GPIO0 is configured as normal GPIO or LCD miscellaneous signal with command set_gpio_conf, this command will be ignored.
0x11	exit_sleep_mode	Turn on the panel. This command will pull high the GPIO0. If GPIO0 is configured as normal GPIO or LCD miscellaneous signal with command set_gpio_conf, this command will be ignored.
0x12	enter_partial_mode	Part of the display area is used for image display.
0x13	enter_normal_mode	The whole display area is used for image display.
0x20	exit_invert_mode	Displayed image colors are not inverted.
0x21	enter_invert_mode	Displayed image colors are inverted.
0x26	set_gamma_curve	Selects the gamma curve used by the display panel.
0x28	set_display_off	Blanks the display panel
0x29	set_display_on	Show the image on the display panel
0x2A	set_column_address	Set the column address
0x2B	set_page_address	Set the page address
0x2C	write_memory_start	Transfer image information from the host processor interface to the SSD1963 starting at the location provided by set_column_address and set_page_address
0x2E	read_memory_start	Transfer image data from the SSD1963 to the host processor interface starting at the location provided by set_column_address and set_page_address
0x30	set_partial_area	Defines the partial display area on the display panel
0x33	set_scroll_area	Defines the vertical scrolling and fixed area on display area
0x34	set_tear_off	Synchronization information is not sent from the SSD1963 to the host processor
0x35	set_tear_on	Synchronization information is sent from the SSD1963 to the host processor at the start of VFP
0x36	set_address_mode	Set the read order from frame buffer to the display panel
0x37	set_scroll_start	Defines the vertical scrolling starting point
0x38	exit_idle_mode	Full color depth is used for the display panel
0x39	enter_idle_mode	Reduce color depth is used on the display panel.
0x3A	Reserved	Reserved
0x3C	write_memory_continue	Transfer image information from the host processor interface to the SSD1963 from the last written location
0x3E	read_memory_continue	Read image data from the SSD1963 continuing after the last read_memory_continue or read_memory_start

Hex Code	Command	Description
0x44	set_tear_scanline	Synchronization information is sent from the SSD1963 to the host processor when the display panel refresh reaches the provided scanline
0x45	get_scanline	Get the current scan line
0xA1	read_ddb	Read the DDB from the provided location
0xA8	Reserved	Reserved
0xB0	set_lcd_mode_	Set the LCD panel mode and resolution
0xB1	get_lcd_mode	Get the current LCD panel mode, pad strength and resolution
0xB4	set_hori_period	Set front porch
0xB5	get_hori_period	Get current front porch settings
0xB6	set_vert_period	Set the vertical blanking interval between last scan line and next LFRAME pulse
0xB7	get_vert_period	Set the vertical blanking interval between last scan line and next LFRAME pulse
0xB8	set_gpio_conf	Set the GPIO configuration. If the GPIO is not used for LCD, set the direction. Otherwise, they are toggled with LCD signals.
0xB9	get_gpio_conf	Get the current GPIO configuration
0xBA	set_gpio_value	Set GPIO value for GPIO configured as output
0xBB	get_gpio_status	Read current GPIO status. If the individual GPIO was configured as input, the value is the status of the corresponding pin. Otherwise, it is the programmed value.
0xBC	set_post_proc	Set the image post processor
0xBD	get_post_proc	Set the image post processor
0xBE	set_pwm_conf	Set the image post processor
0xBF	get_pwm_conf	Set the image post processor
0xC0	set_lcd_gen0	Set the rise, fall, period and toggling properties of LCD signal generator 0
0xC1	get_lcd_gen0	Get the current settings of LCD signal generator 0
0xC2	set_lcd_gen1	Set the rise, fall, period and toggling properties of LCD signal generator 1
0xC3	get_lcd_gen1	Get the current settings of LCD signal generator 1
0xC4	set_lcd_gen2	Set the rise, fall, period and toggling properties of LCD signal generator 2
0xC5	get_lcd_gen2	Get the current settings of LCD signal generator 2
0xC6	set_lcd_gen3	Set the rise, fall, period and toggling properties of LCD signal generator 3
0xC7	get_lcd_gen3	Get the current settings of LCD signal generator 3
0xC8	set_gpio0_rop	Set the GPIO0 with respect to the LCD signal generators using ROP operation. No effect if the GPIO0 is configured as general GPIO.
0xC9	get_gpio0_rop	Get the GPIO0 properties with respect to the LCD signal generators.
0xCA	set_gpio1_rop	Set the GPIO1 with respect to the LCD signal generators using ROP operation. No effect if the GPIO1 is configured as general GPIO.
0xCB	get_gpio1_rop	Get the GPIO1 properties with respect to the LCD signal generators.
0xCC	set_gpio2_rop	Set the GPIO2 with respect to the LCD signal generators using ROP operation. No effect if the GPIO2 is configured as general GPIO.

Hex Code	Command	Description
0xCD	get_gpio2_rop	Get the GPIO2 properties with respect to the LCD signal generators.
0xCE	set_gpio3_rop	Set the GPIO3 with respect to the LCD signal generators using ROP operation. No effect if the GPIO3 is configured as general GPIO.
0xCF	get_gpio3_rop	Get the GPIO3 properties with respect to the LCD signal generators.
0xD0	set_dbc_conf	Set the dynamic back light configuration
0xD1	get_dbc_conf	Get the current dynamic back light configuration
0xD4	set_dbc_th	Set the threshold for each level of power saving
0xD5	get_dbc_th	Get the threshold for each level of power saving
0xE0	set_pll	Start the PLL. Before the start, the system was operated with the crystal oscillator or clock input
0xE2	set_pll_mn	Set the PLL
0xE3	get_pll_mn	Get the PLL settings
0xE4	get_pll_status	Get the current PLL status
0xE5	set_deep_sleep	Set deep sleep mode
0xE6	set_lshift_freq	Set the LSHIFT (pixel clock) frequency
0xE7	get_lshift_freq	Get current LSHIFT (pixel clock) frequency setting
0xE8	Reserved	Reserved
0xE9	Reserved	Reserved
0xF0	set_pixel_data_interface	Set the pixel data format of the parallel host processor interface
0xF1	get_pixel_data_interface	Get the current pixel data format settings
0xFF	Reserved	Reserved

Note: command descriptions please see SSD1963 Datasheet

## 8 Absolute Maximum Ratings

PARAMETER	SYMBOL	MIN	MAX	UNIT
Supply Voltage (Analog)	VDD~GND	-0.3	5.5	V
Operating Temperature	TOP	-20	70	° C
Storage Temperature	TST	-30	80	° C
Humidity	RH	-	90%(Max 60° C)	RH

## 9 Electrical Characteristics

PARAMETER	SYMBOL	MIN	TYP	MAX	UNIT
Analog operating voltage	VDD	4.5	5.0	5.5	V
Logic operating voltage	VDDI	3.0	3.3	3.6	
Input Voltage ' H ' level	VIH	0.7VDDI	-	VDDI	
Input Voltage ' L ' level	VIL	GND	-	0.3VDDI	
Output Voltage ' H ' level	VOH	VDDI-0.4	-	VDDI	
Output Voltage ' L ' level	VOL	GND	-	GND+0.4	

## 10 Backlight Characteristics

ITEM	SYMBOL	MIN	TYP	MAX	UNIT
Voltage for LED backlight	$V_f$	-	24.8	-	V
Current for LED backlight	$I_f$	-	40	-	mA
Power consumption	Wbl	-	992	-	mW
Uniformity	Avg	80	-	-	%
LED Life Time	-	30000	40000	-	Hrs

Note:

1. The LED life time is defined as the module brightness decrease to 50% original brightness at  $T_a=25^{\circ}\text{C}$ , 60%RH  $\pm 5\%$ .
2. The life time of LED will be reduced if LED is driven by high current, high ambient temperature and humidity conditions.
3. Typical operating life time is an estimated data.
4. Permanent damage to the device may occur if maximum values are exceeded or reverse voltage is loaded. Functional operation should be restricted to the conditions described under normal operating conditions.

## 11 LCD Optical specifications

Item	Symbol	Condition	Specification			Unit	Remark
			Min	Typ	Max		
Response time (By Quick)	Tr+Tf	$\theta = 0^\circ$	-	20	30	ms	Note 5
Contrast ratio	CR	$\theta = 0^\circ$	500	600	-		Note 2,6
Viewing angle	Top	$CR \geq 10$	50	60	-	Deg.	Note 2,6,7
	Bottom	$CR \geq 10$	60	70	-		
	Left	$CR \geq 10$	70	80	-		
	Right	$CR \geq 10$	70	80	-		
Color Filter Chromaticity with C light	Wx	$\theta = 0^\circ$	Typ -0.03	0.301	Typ +0.03		Note 3
	Wy			0.337			
	Rx			0.605			
	Ry			0.324			
	Gx			0.303			
	Gy			0.562			
	Bx			0.144			
	By			0.172			
NTSC			-	50	%		Note 3
Transmittance	Trans		-	6.85	%		Note 4

Note 1: Ambient temperature = 25°C.

Note 2: To be measured with a viewing cone of 2° by Topcon luminance meter BM-5A.

Note 3: To be measured with Otsuta chromaticity meter LCF-2100M, CF only measure under C light simulation.

Note 4: Shipping status is cell without polarizer. Transmittance of Specification is cell with polarizer. The tolerance of Transmittance is ±10%.

Note 5: Definition of response time:

The output signals of TRD-100 are measured when the input signals are changed to “White” (falling time) and from “White” to “Black” (rising time), respectively. The interval is between the 10% and 90% of amplitudes. Refer to figure as below.

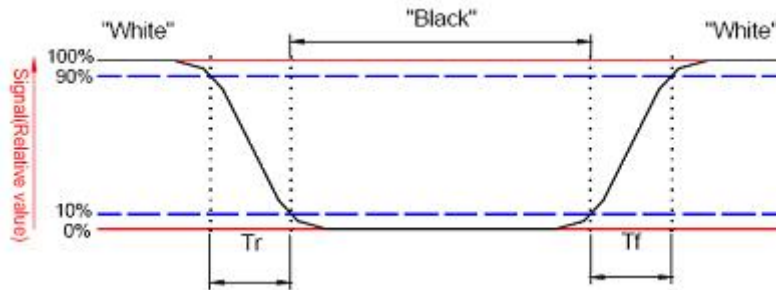

Note 6: Definition of contrast ratio:

Contrast ratio is calculated by the following formula.

$$\text{Contrast ratio (CR)} = \frac{\text{Brightness on the "white" state}}{\text{Brightness on the "black" state}}$$

Note 7: Definition of viewing angle

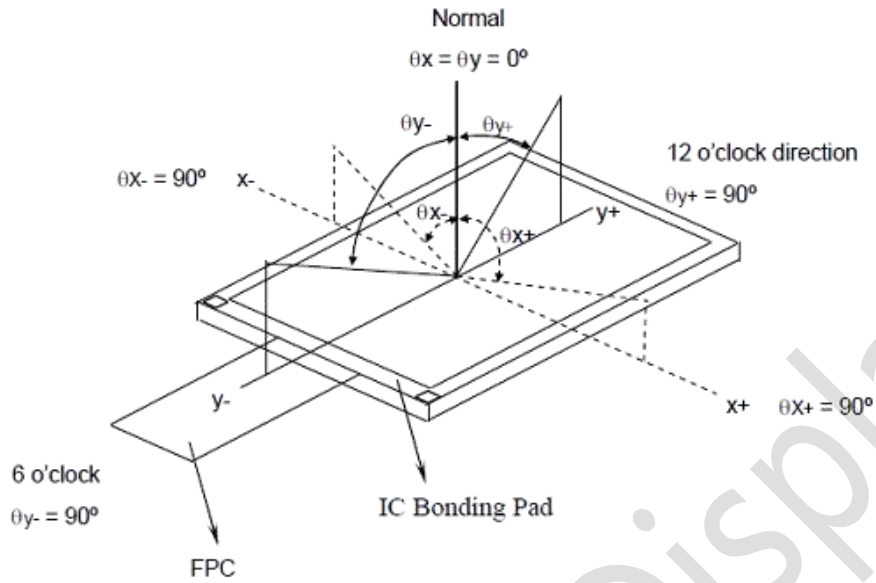

Note 8: Optical characteristic measurement setup.

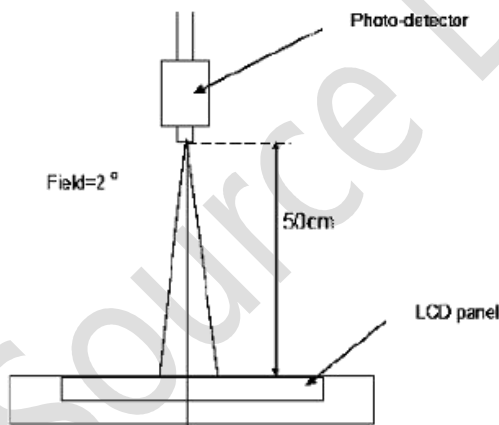

Note 9:

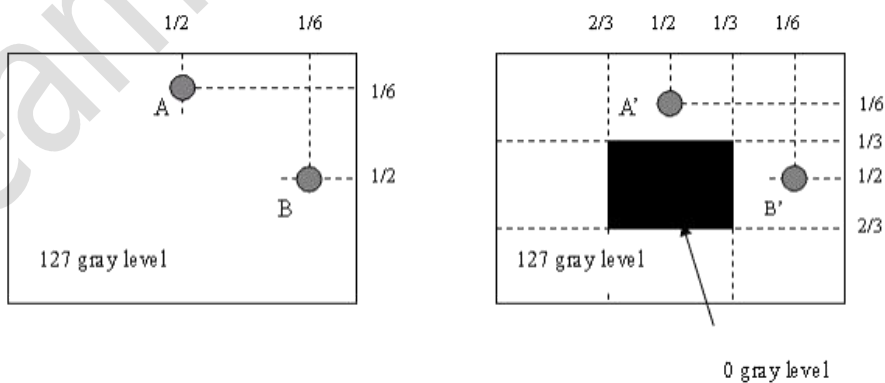

$1 \text{ LA-LA}' / \text{LA} \times 100\% = 2\% \text{ max.}$ , LA and LA' are brightness at location A and A'.

$1 \text{ LB-LB}' / \text{LB} \times 100\% = 2\% \text{ max.}$ , LB and LB' are brightness at location B and B'.

## 12 Capacitive Touch Panel specifications

### 12.1 Mechanical characteristics

DESCRIPTION	INL SPECIFICATION	REMARK
Touch Panel Size	4.3	
Outline Dimension (OD)	123.04(H) x 84.46(V) mm	Cover Lens Outline
Product Thickness	1.73mm	With gasket
Glass Thickness	0.7mm	
View Area	96.04x54.86mm	
Input Method	5 Fingers	
Activation Force	Touch	
Surface Hardness	≥6H	

### 12.2 Electrical characteristics

DESCRIPTION		SPECIFICATION
Operating Voltage		DC 2.8~3.3V
Power Consumption (IDD)	Active Mode	TBD
	Sleep Mode	TBD
Interface		I <sup>2</sup> C
Controller IC		FT5316DME
I <sup>2</sup> C address		0x70
Resolution		480*272

### 12.3 Interface timing characteristics

PARAMETER	MIN	MAX	UNIT
SCL Frequency	-	400	KHz
Bus Free Time Between a STOP and START Condition	4.7	-	uS
Hold Time (repeated) START Condition	4.0	-	uS
Data Setup Time	250	-	nS
Setup Time for Repeated START Condition	4.7	-	uS
Setup Time for STOP Condition	4.0	-	uS



### 13 RELIABILITY TEST

NO.	TEST ITEM	TEST CONDITION	INSPECTION AFTER TEST
1	High Temperature Storage	80±2°C/96 hours	Inspection after 2~4 hours storage at room temperature and humidity. The condensation is not accepted. The sample shall be free from defects:  1. Air bubble in the LCD 2. Seal leak 3. Non-display 4. Missing segments 5. Glass crack
2	Low Temperature Storage	-30±2°C/96 hours	
3	High Temperature Operating	70±2°C/96 hours	
4	Low Temperature Operating	-20±2°C/96 hours	
5	Temperature Cycle	-30±2°C ~ 25~ 80± 2°C × 10 cycles (30 min.) (5min.) (30min.)	
6	Damp Proof Test	60°C ±5°C × 90%RH/96 hours	
7	Vibration Test	Frequency 10Hz~55Hz Stroke: 1.5mm Sweep: 10Hz~150 Hz~10Hz 2 hours For each direction of X, Y, Z	
8	Shock Test	Half-sine, wave, 300m/s	
9	Packing Drop Test	Height: 80 cm 1 corner, concrete floor	
10	Electrostatic Discharge Test	C=150pF, R=330 Ω Air: ±8KV 150pF/330Ω 30 times Contact: ±4KV,20 times	

### 14 Suggestions for using LCD modules

#### 14.1 Handling of LCM

1. The LCD screen is made of glass. Don't give excessive external shock, or drop from a high place.
2. If the LCD screen is damaged and the liquid crystal leaks out, do not lick and swallow. When the liquid is attach to your hand, skin, cloth etc, wash it off by using soap and water thoroughly and immediately.
3. Don't apply excessive force on the surface of the LCM.
4. If the surface is contaminated, clean it with soft cloth. If the LCM is severely contaminated, use Isopropyl alcohol/Ethyl alcohol to clean. Other solvents may damage the polarizer. The following solvents is especially prohibited: water , ketone Aromatic solvents etc.
5. Exercise care to minimize corrosion of the electrode. Corrosion of the electrodes is accelerated by water droplets, moisture condensation or a current flow in a high-humidity environment.
6. Install the LCD Module by using the mounting holes. When mounting the LCD module make sure it is free of twisting, warping and distortion. In particular, do not forcibly pull or bend the I/O cable or the backlight cable.
7. Don't disassemble the LCM.

8. To prevent destruction of the elements by static electricity, be careful to maintain an optimum work environment.
  - Be sure to ground the body when handling the LCD modules.
  - Tools required for assembling, such as soldering irons, must be properly grounded.
  - To reduce the amount of static electricity generated, do not conduct assembling and other work under dry conditions.
  - The LCD module is coated with a film to protect the display surface. Exercise care when peeling off this protective film since static electricity may be generated.
9. Do not alter, modify or change the the shape of the tab on the metal frame.
10. Do not make extra holes on the printed circuit board, modify its shape or change the positions of components to be attached.
11. Do not damage or modify the pattern writing on the printed circuit board.
12. Absolutely do not modify the zebra rubber strip (conductive rubber) or heat seal connector
13. Except for soldering the interface, do not make any alterations or modifications with a soldering iron.
14. Do not drop, bend or twist LCM.

## 14.2 Storage

1. Store in an ambient temperature of 5 to 45 °C, and in a relative humidity of 40% to 60%. Don't expose to sunlight or fluorescent light.
2. Storage in a clean environment, free from dust, active gas, and solvent.
3. Store in antistatic container.

