



深圳市一众显示科技有限公司

SHEN ZHEN TEAM SOURCE DISPLAY TECH. CO, LTD.

TFT-LCD Module Specification

Module NO.: TST043WQIS-21P

Version: V1.0

APPROVAL FOR SPECIFICATION

APPROVAL FOR SAMPLE

For Customer' s Acceptance:	
Approved by	Comment

Team Source Display:		
Presented by	Reviewed by	Organized by

Version No.	Date	Content	Remark
V1.0	2017-7-21	Initial Release	

Contents

1.0	General description	p.5
2.0	Absolute maximum ratings	p.6
3.0	Optical characteristics	p.7
4.0	Block diagram	p.10
5.0	Interface pin connection	p.11
6.0	Electrical characteristics	p.12
7.0	Reliability test items	p.15
8.0	Outline dimension	p.16
9.0	Package specification	p.17
10.0	General precaution	p.18

1.0 GENERAL DESCRIPTION

1.1 Introduction

TS Display model TST043WQIS-21P is a color active matrix thin film transistor (TFT) liquid crystal display (LCD) that uses amorphous silicon TFT as a switching device. This model is composed of a TFT LCD panel, a driving circuit, and a backlight system. This TFT LCD has a 4.3 (16:9) inch diagonally measured active display area with 480*272 (480 horizontal by 272 vertical pixel) resolution.

1.2 Features

- 4.3 (16:9 diagonal) inch configuration
- 6 bits +FRC driver with 1 channel TTL interface
- ROHS and Halogen-Free Compliance
- Driver IC ST7282

1.3 Applications

- Personal Navigation Device
- Multimedia applications and Others AV system

1.4 General information

Item	Specification	Unit	Note
Outline Dimension	105.45x 67.2 x 3.0 (Typ.)	mm	
Display area	95.04(H) x 53.86(V)	mm	
Number of Pixel	480 RGB (H) x 272(V)	pixels	16:9WVGA
Pixel pitch	0.198(H) x 0.198(V)	mm	
Pixel arrangement	RGB Vertical stripe	--	
Display mode	Normally white	--	TN Model
Surface Treatment	Antiglare	--	
Dirver Element	a-Si TFT	--	
LED	2x4	PCS	Establish

2.0 ABSOLUTE MAXIMUM RATINGS

2.1 Electrical Absolute Rating

2.1.1 TFT LCD Module

Item	Symbol	Min.	Max.	Unit	Note
Power supply voltage	V_{DD}	-0.5	4.5	V	GND=0
Logic Signal Input Level	V_i	-0.3	$V_{DD} +0.3$	V	

2.1.2 Back-Light Unit

Item	Symbol	MIN	TYP.	Max.	U	Note
LED current	I_L		40		mA	(1)(2)(3)
LED voltage	V	12	12.8	14	V	(1)(2)(3)
LED Uniformity	ΔI_v	80	85	--	%	
(LED+LCD)Luminance	L_v	270	300	--	Cd/m ²	

Note

(1) Permanent damage may occur to the LCD module if beyond this specification.

Functional operation should be restricted to the conditions described under normal operating conditions.

(2) $T_a = 25 \pm 2^\circ\text{C}$

(3) Test Condition: LED current 40 mA. The LED lifetime could be decreased if operating I_L is larger than 50 mA.

2.2 Environment Absolute Rating

Item	Symbol	Min.	Max.	Unit	Note
Operating Temperature	T_{opa}	-20	60	$^\circ\text{C}$	
Storage Temperature	T_{stg}	-30	70	$^\circ\text{C}$	

3.0 OPTICAL CHARACTERISTICS

3.1 Optical specification

Item	Symbol	Condition	Min.	Typ.	Max.	Unit	Note
Threshold voltage	V_{sat}		—	2.4	—		(6)
	V_{th}		—	1.4	—		(6)
Transmittance (With PZ)	T		—	5.92	—	%	
Contrast	CR		480	600	—		(1)(2)
Response time	Rising	TR	—	3	6	msec	(1)(3)
	Falling	TF	—	7	14		
White luminance(center)	YL	$\Theta = 0$	270	300	-	cd/m ²	I=20mA
Color gamut	S	Normal viewing angle	-	50	—	%	C light
Color chromaticity (CIE1931)	White	W_x	0.292	0.307	0.322		(1)(4) CF Glass C light
		W_y	0.333	0.348	0.363		
	Red	R_x	0.616	0.631	0.646		
		R_y	0.327	0.342	0.357		
Green	G_x	0.306	0.321	0.336			

		Gy		0.538	0.553	0.568	
	Blue	Bx		0.134	0.149	0.164	
		By		0.168	0.183	0.198	
Viewing angle	Hor.	⊕ L	CR>10	65	75	—	
		⊕ R		65	75	—	
	Ver.	⊕ U		50	60		
		⊕ D		60	70		
Optima View Direction		6 O' clock					(5)

3.2 Measuring Condition

- Measuring surrounding: dark room
- LED current I_L: 40mA
- Ambient temperature: 25±2°C
- 15min. warm-up time.

3.3 Measuring Equipment

- FPM520 of Westar Display technologies, INC., which utilized SR-3 for Chromaticity and BM-5A for other optical characteristics.
- Measuring spot size: 20 ~ 21m

Note (1) Definition of Viewing Angle: 12' O'clock

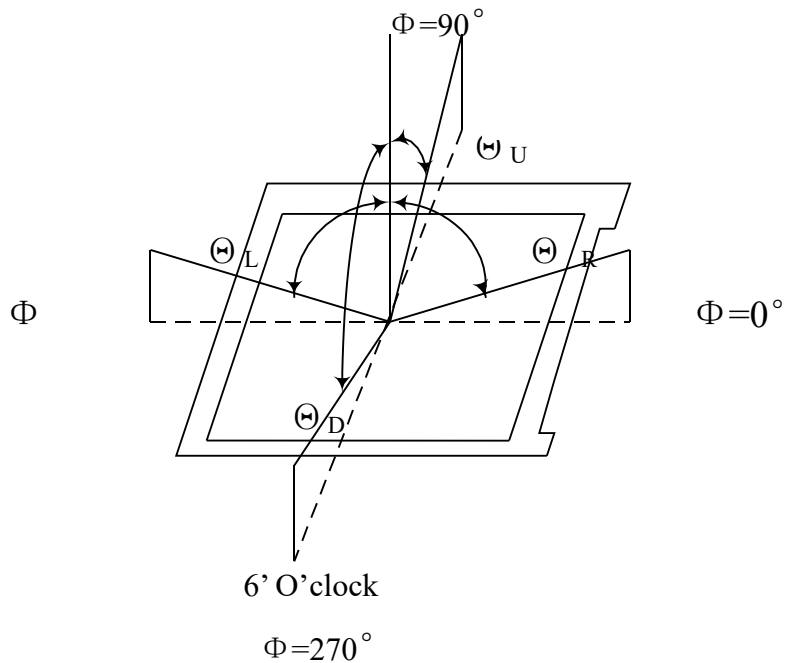

Note (2) Definition of Contrast Ratio (CR):
measured at the center point of pane

Luminance with all pixels white

CR = _____

Luminance with all pixels black

Note (3) Definition of Response Time: Sum of T_R and T_F

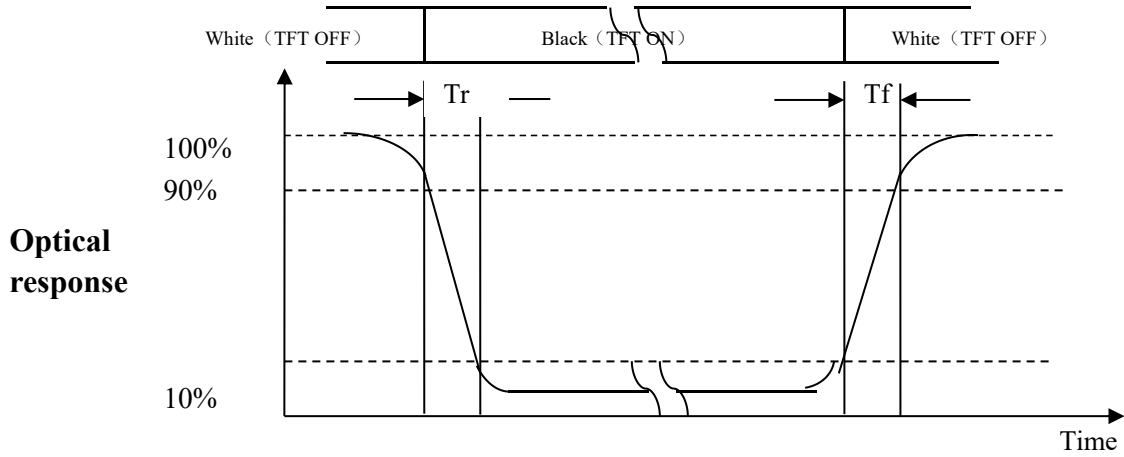

Note (4) Definition of optical measurement setup

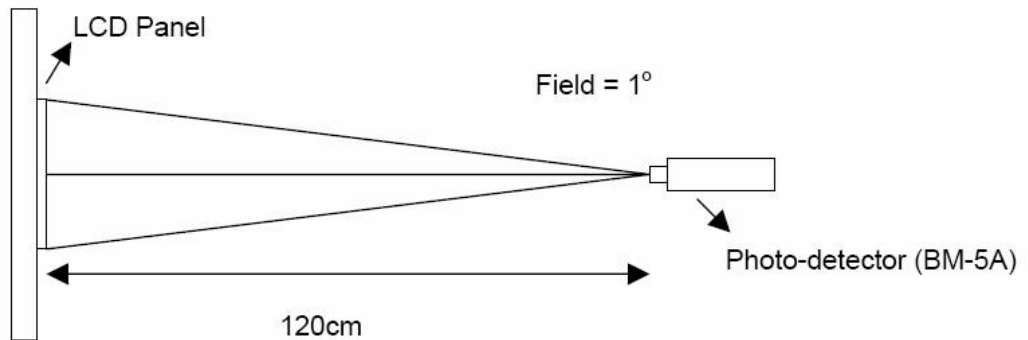

Note (5) Rubbing Direction (The different Rubbing Direction will cause the different optimal view direction).

Note (6) Definition of V_{sat} and V_{th} (at 20°C)

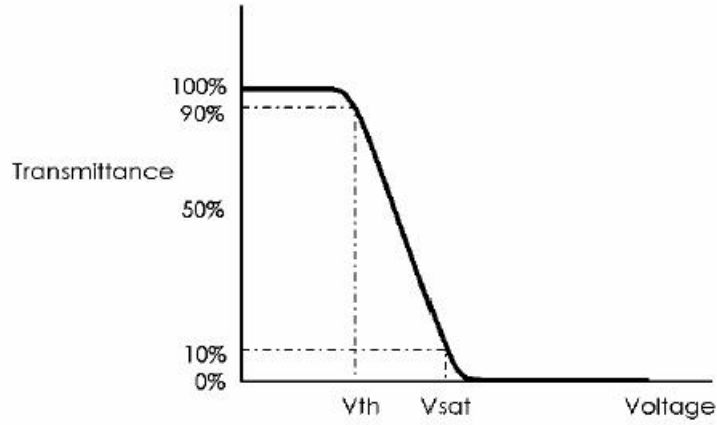

4.0 BLOCK DIAGRAM

4.1 Pixel Format

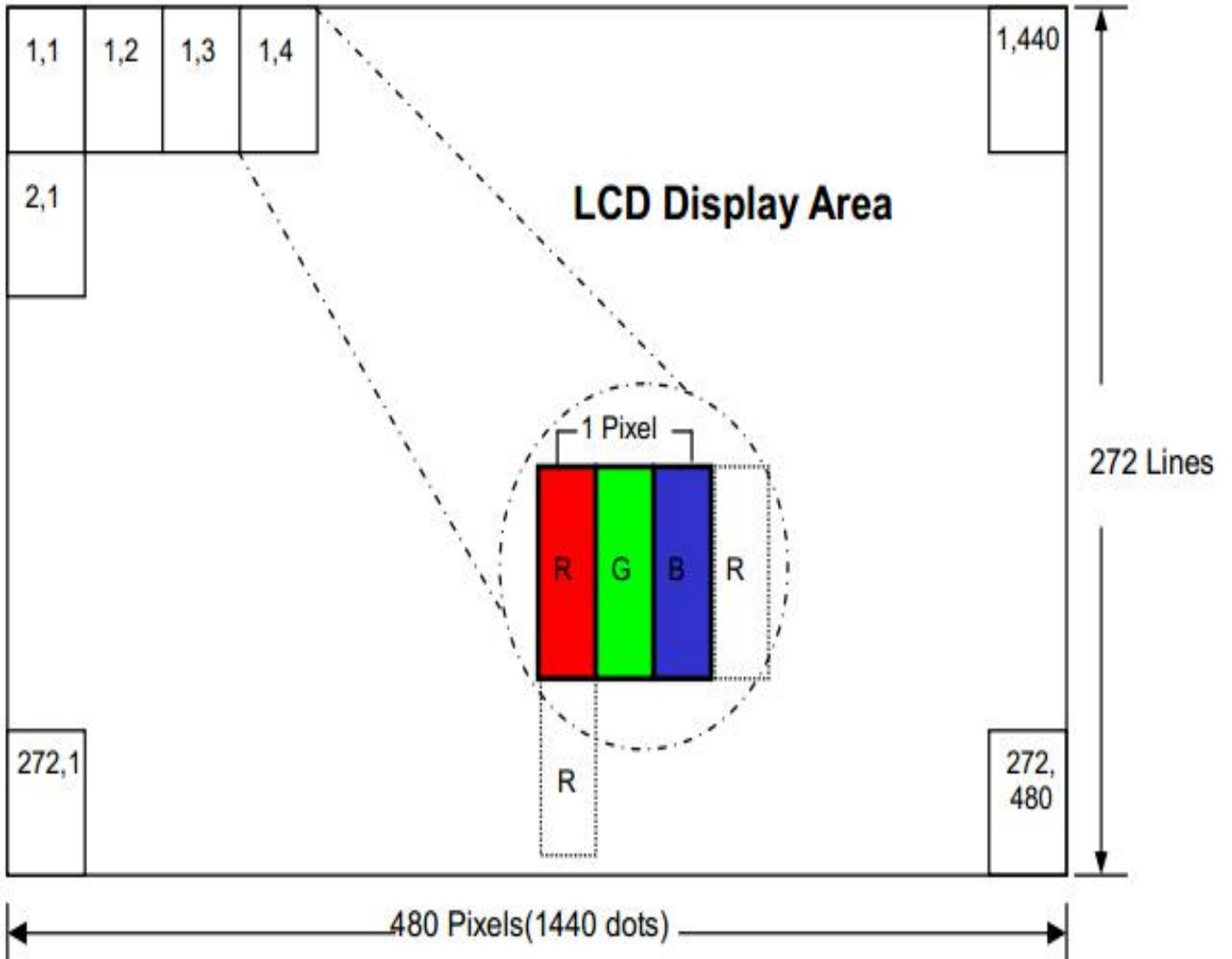

5.0 INPUT INTERFACE PIN ASSIGNMENT

FPC connector is used for electronics interface.

The recommended model is FH19SC-40S-0.5SH (51) manufactured by HIROSE.

Pin No.	Symbol	I/O	Function
1	LED-	P	Power for LED backlight cathode
2	LED+	P	Power for LED backlight anode
3	GND	P	Power ground
4	V _{DD}	P	Power voltage
5	R0	I	Red data (LSB)
6	R1	I	Red data
7	R2	I	Red data
8	R3	I	Red data
9	R4	I	Red data
10	R5	I	Red data
11	R6	I	Red data
12	R7	I	Red data (MSB)
13	G0	I	Green data (LSB)
14	G1	I	Green data
15	G2	I	Green data
16	G3	I	Green data
17	G4	I	Green data
18	G5	I	Green data
19	G6	I	Green data
20	G7	I	Green data (MSB)
21	B0	I	Blue data (LSB)
22	B1	I	Blue data
23	B2	I	Blue data
24	B3	I	Blue data
25	B4	I	Blue data
26	B5	I	Blue data
27	B6	I	Blue data
28	B7	I	Blue data (MSB)
29	DGND	I	Digital ground
30	DCLK	I	Pixel clock
31	DISP	I	Display on/ off
32	HSYNC	I	Horizontal sync signal
33	VSYNC	I	Vertical sync signal
34	DE	I	Data enable
35	NC	-	No Connect
36	GND	P	Power ground
37	X R	I/O	Right electrode - differential analog
38	Y B	I/O	Bottom electrode - differential analog
39	X L	I/O	Left electrode - differential analog
40	Y T	I/O	Top electrode - differential analog

I/O: I: input, O: output, P: power

6.0 ELECTRICAL CHARACTERISTICS

6.1 TFT LCD Module

Item	Symbol	Min.	Typ.	Max.	Unit	Note
Supply voltage	V_{DD}	3.0	3.3	3.6	V	
Input signal voltage	V_{iH}	$0.7 V_{DD}$	-	V_{DD}	V	Note (1)
	V_{iL}	GND	-	$0.3 V_{DD}$	V	Note (1)
Current of power supply	I_{DD}	-	-	220	mA	$V_{DD} = 3.3V$

Note (1): HSYNC, VSYNC, DE, R/G/B Data

Note (2): GND=0V

6.2 AC Characteristics

Item	Symbol	Min.	Typ.	Max.	Unit	Note
DCLK period time	T_{cph}	83.3	11.1	125	ns	Parallel 18bit RGB mode
DCLK rising time	T_{fck}			9	ns	
DCLK falling time	T_{cph}			9	ns	
DCLK pulse duty	T_{cwh}	50	50	60	%	
DE setup time	T_{desu}	12			ns	
DE hold time	T_{dehd}	12			ns	
HSYNC pulse width	T_{hwh}	1			DCLK	
HSYNC setup time	T_{hsu}	12			ns	
HSYNC hold time	T_{hhd}	12			ns	
VSYNC pulse width	T_{vwh}	1			Th	
VSYNC setup time	T_{vsu}	12			ns	
VSYNC hold time	T_{vhhd}	12			ns	
Data setup time	T_{dsu}	12			ns	
Data hold time	T_{dhhd}	12			ns	

6.3 Timing Diagram of interface Signal

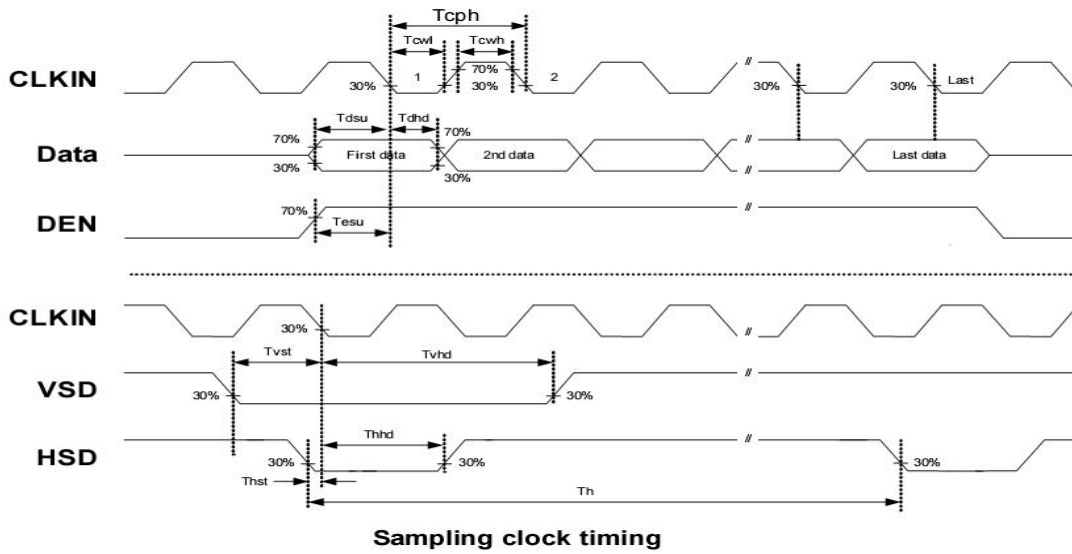

Sampling clock timing

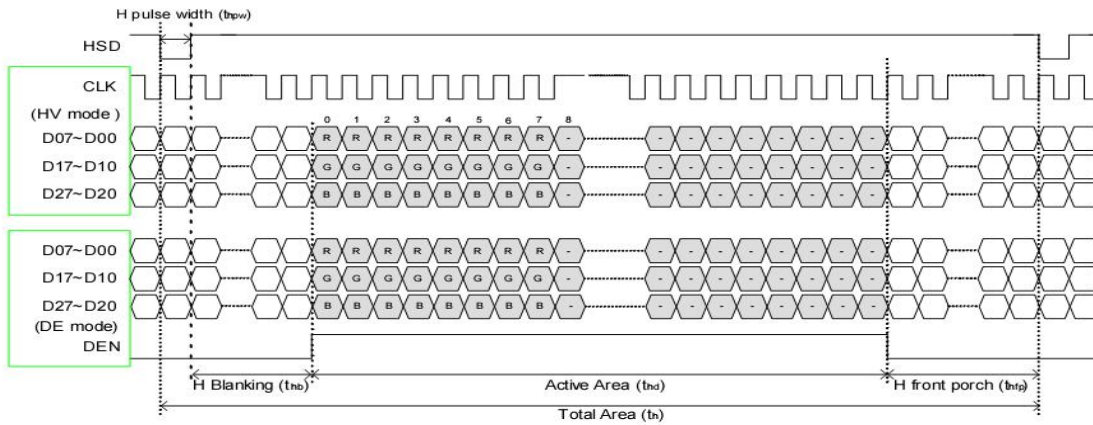

Horizontal display timing range

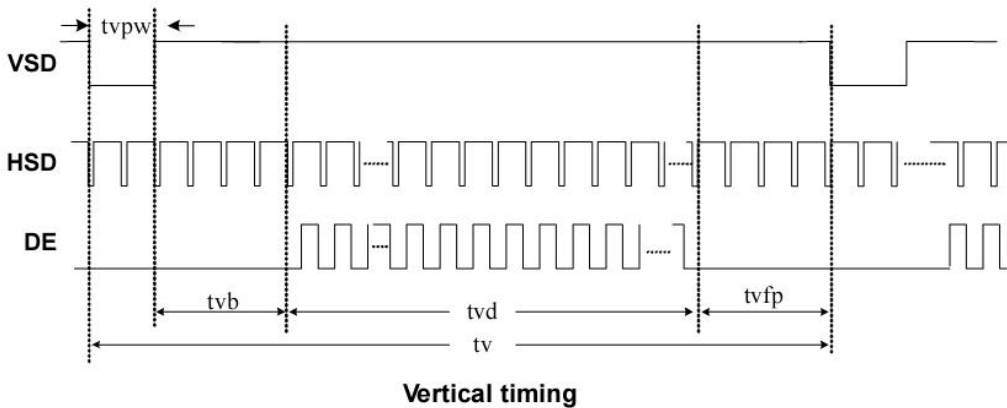

Vertical timing

6.4 Power Sequence

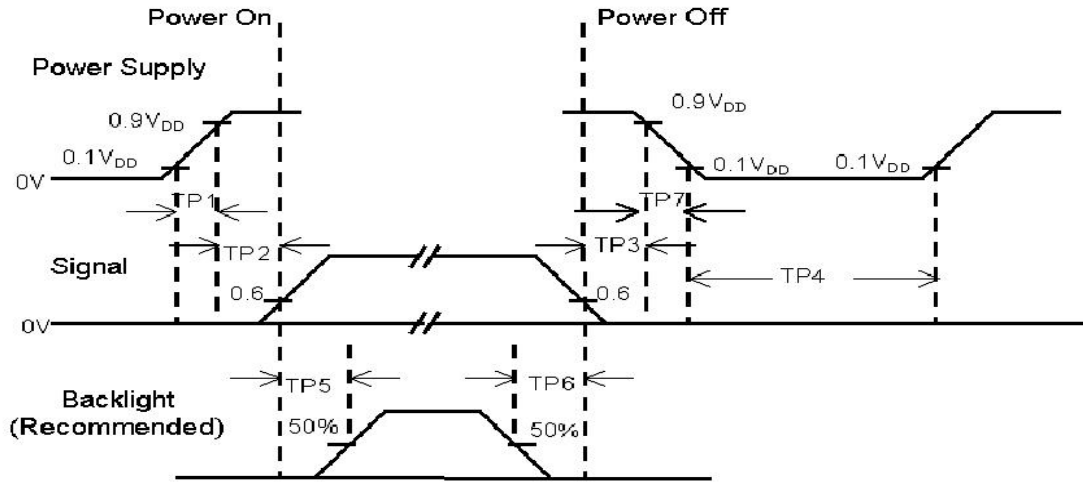

Item	Min.	Typ.	Max.	Unit	Remark
TP1	0.5	--	10	msec	
TP2	0	--	50	msec	
TP3	0	--	50	msec	
TP4	1000	--	--	msec	
TP5	200	--	--	msec	
TP6	200	--	--	msec	
TP7	0.5	--	10	msec	

Note: (1) The supply voltage of the external system for the module input should be the same as the definition of V_{DD}.

(2) Apply the lamp voltage within the LCD operation range. When the back-light turns on before the LCD operation or the LCD turns off before the back-light turns off, the display may momentarily become white.

(3) In case of VDD = off level, please keep the level of input signal on the low or keep a high impedance.

(4) TP4 should be measured after the module has been fully discharged between power off and on period.

(5) Interface signal shall not be kept at high impedance when the power is on.

7.0 RELIABILITY TEST ITEMS

No.	Item	Conditions	Remark
1	High Temperature Storage	Ta=+70oC, 240hrs	
2	Low Temperature Storage	Ta=-30oC, 240hrs	
3	High Temperature Operation	Ta=+60oC, 240hrs	
4	Low Temperature Operation	Ta=-20oC, 240hrs	
5	High Temperature and High Humidity (operation)	Ta=+50oC, 90%RH, 240hrs	
6	Thermal Cycling Test (non operation)	-30oC(30min) → +70oC(30min), 200cycles	
7	Electrostatic Discharge	± 200V,200pF(0Ω) 1 time/each terminal	
8	Vibration	1.Random: 1.04Grms, 5~500Hz, X/Y/Z, 30min/each direction 2. Sine: Freq. Range: 8~33.3Hz Stoke: 1.3mm Sweep: 2.9G, 33.3~400Hz X/Z: 2hr, Y: 4hr, cyc: 15min	
9	Shock	100G, 6ms, ±X, ±Y, ±Z 3 time for each direction	JIS C7021, A-10 (Condition A)
10	Vibration (with carton)	Random: 0.015G ² /Hz, 5~200Hz -6dB/Octave, 200~400Hz XYZ each direction: 2hr	
11	Drop (with carton)	Height: 60cm 1 corner, 3 edges, 6 surfaces	JIS Z0202

Note: There is no display function NG issue occurred, all the cosmetic specification is judged before the reliability stress.

PIN	DESCRIPTION	PIN	DESCRIPTION
1	VLED-	21	B0
2	VLED+	22	B1
3	GND	23	B2
4	VDD	24	B3
5	R0	25	B4
6	R1	26	B5
7	R2	27	B6
8	R3	28	B7
9	R4	29	GND
10	R5	30	DCLK
11	R6	31	STBYB
12	R7	32	HS
13	G0	33	VS
14	G1	34	DE
15	G2	35	NC
16	G3	36	GND
17	G4	37	XR/X+
18	G5	38	YD/Y-
19	G6	39	XL/X-
20	G7	40	YU/Y+

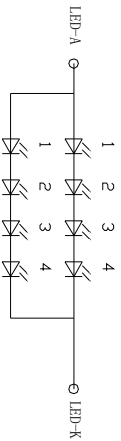
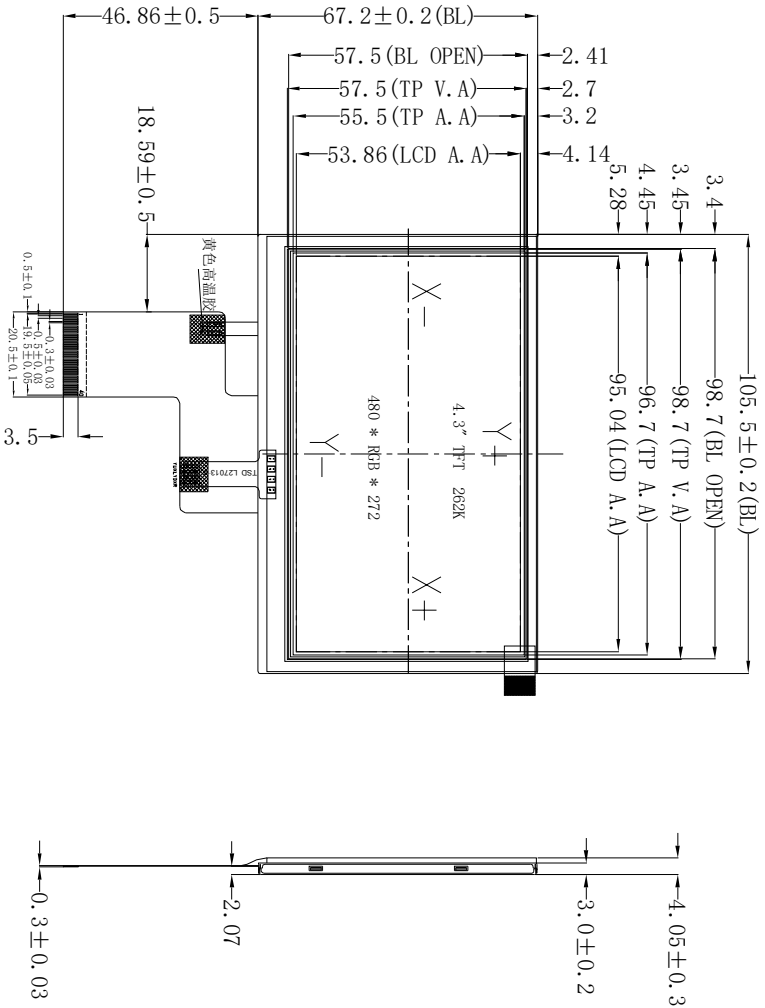

LCD Type	4.3" TFT, Transmissive, Normally white, TN
Resolution	480(RGB)*272
View Direction	12 O'CLOCK
Driver IC	ST7282
Color Depth	16.7M
Interface Types	TTL(RGB24-bit)
Operating voltage	3.3V
TP/Lens	With RTP
Backlight LEDs	8 LEDs, 40mA, 12.4V
Surface luminance	320 cd/m ²
Operating temperature	-20 °C ~ 70 °C
Storage Temperature	-30 °C ~ 80 °C
Storage Humidity	60°C 90% max

" Need to pay attention to		the key size with *		DONG GUAN TEAM SOURCE DISPLAY TECH. CO, LTD.		东莞市一众显示科技有限公司	
版本 (Version)	变更记录 (Change History)	日期 (Date)	视角 (View):	比例 (Proportion):	设计 (DESIGN)	审核 (AUDITING)	批准 (APPROVED)
V1			单位 (Unit):	1 : 1	Ar-on	Perix	
V2			产品型号 (Product Type):	TST043WQIS-21P	2017.7.21	2017.7.21	

GENERAL TOLERANCE:±0.2



9.0 PACKAGE SPECIFICATION

9.1 Packing form

PARAMETER	Specification	Unit
Outside box	390(L) x 350(W) x 480(H)	mm
Inside pearl wool box	375(L) x 340(W) x 100(H)	mm
Product quantity of Inside box	36	pcs
Total product quantity	36*4=144	pcs
Total weight	14 ± 0.5	Kg

10.0 GENERAL PRECAUTION

10.1 Use Restriction

This product is not authorized for use in life supporting systems, aircraft navigation control systems, military systems and any other application where performance failure could be life-threatening or otherwise catastrophic.

10.2 Disassembling or Modification

Do not disassemble or modify the module. It may damage sensitive parts inside LCD module, and may cause scratches or dust on the display. TSDisplay does not warrant the module, if customers disassemble or modify the module.

10.3 Breakage of LCD Panel

10.3.1 .If LCD panel is broken and liquid crystal spills out, do not ingest or inhale liquid crystal, and do not contact liquid crystal with skin.

10.3.2 .If liquid crystal contacts mouth or eyes, rinse out with water immediately.

10.3.3 .If liquid crystal contacts skin or cloths, wash it off immediately with alcohol and rinse thoroughly with water.

10.3.4 .Handle carefully with chips of glass that may cause injury, when the glass is broken.

10.4 Electric Shock

10.4.1 .Disconnect power supply before handling LCD module.

10.4.2 .Do not pull or fold the LED cable.

10.4.3 .Do not touch the parts inside LCD modules and the fluorescent LED's connector or cables in order to prevent electric shock.

10.5 Absolute Maximum Ratings and Power Protection Circuit

10.5.1 .Do not exceed the absolute maximum rating values, such as the supply voltage variation, input voltage variation, variation in parts' parameters, environmental temperature, etc., otherwise LCD module may be damaged.

10.5.2 .Please do not leave LCD module in the environment of high humidity and high temperature for a long time.

10.5.3 .It's recommended to employ protection circuit for power supply.

10.6 Operation

10.6.1 Do not touch, push or rub the polarizer with anything harder than HB pencil lead.

10.6.2 Use fingerstalls of soft gloves in order to keep clean display quality, when persons handle the LCD module for incoming inspection or assembly.

10.6.3 When the surface is dusty, please wipe gently with absorbent cotton or other soft material.

