

SPECIFICATIONS

PRODUCT : LCD MODULE

MODEL NO. : S69508-DB025MB

CUSTOMER NO.:

SUCCESS			CUSTOMER
PREPARED	CHECKED	APPROVED	APPROVED
CYK	ZC	HJB	

APPROVAL FOR SPECIFICATIONS ONLY

APPROVAL FOR SPECIFICATIONS AND SAMPLE

深圳市宇顺电子股份有限公司

SUCCESS ELECTRONICS LTD

“ Not to use the substances and their applications of SUCCESS Management Standard for Environment-related Substances to be Controlled ”

Address:Block 21-23, Changxing industrial Estate Ⅱ,Changzhen village, Gongming town, ,Shenzhen,China

Tel: +86-755-27179653-2790

STANDARD DOC.	PRODUCT SPEC.	MODULE NO.	S69508-DB025MB	PAGE	2/27
------------------	------------------	---------------	-----------------------	------	------

RECORDS OF REVISION

DATE	REVISED NO.	REVISED DESCRIPTIONS	PREPARED	CHECKED	APPROVED
2015-11-09	01	New release	Caoyunkai	Zhangchao	Hujinbo
2017-01-06	02	Change BL structure	ZX	JJQ	HJB
2019-08-27	03	ADD "MTBF" P4	JiangJQ	DiaoJH	WangYF

STANDARD DOC.	PRODUCT SPEC.	MODULE NO.	S69508-DB025MB	PAGE	3/27
------------------	------------------	---------------	-----------------------	------	------

CONTENTS

1. GENERAL SPECIFICATIONS.....	4
2. BLOCK DIAGRAM.....	5
3. OUTLINE DRAWING.....	6
4. INTERFACE ASSIGNMENT.....	7
5. APPLICATION CIRCUIT.....	8
6. TIMING CHARACTERISTICS.....	9
7. POWER ON/OFF SEQUENCE.....	14
8. RECOMMENDED INITIAL CODES.....	16
9. INSTRUCTION TABLE.....	17
10. ELECTRICAL CHARACTERISTICS.....	18
11. LED BACKLIGHT.....	17
12. OPTICAL CHARACTERISTICS.....	18
13. ENVIRONMENTAL ABSOLUTE MAXIMUM RATINGS.....	20
14. RELIABILITY TEST.....	20
15. THE STANDAND OF INSPECTION.....	21
16. USING LCD MODULES.....	24

STANDARD DOC.	PRODUCT SPEC.	MODULE NO.	S69508-DB025MB	PAGE	4/27
---------------	---------------	------------	-----------------------	------	-------------

1. GENERAL SPECIFICATIONS

1-1.DESCRPTION:

The S69508-DB025MB is a dot matrix mono Liquid Crystal Display Module(LCM).
 This specification covers the delivery requirements for the liquid crystal display delivered by SUCCESS ELECTRONIC to Customer.

1-2. FEATURES

- (1) Display Type: STN Blue, Negative, Transmissive, 12O'clock
- (2) Driving Method: VDD=3.3V, 1/65 duty, 1/9 bias
- (3) Built-in controller: ST7565R
- (4) With White Backlight

1-3.GENERAL SPECIFICATION

ITEM	SPECIFICATIONS	UNIT
DISP.CONSTRUCTION	128*64 Dots	--
OUTLINE DIMENSIONS	67.15(W)*48.15(H)*5.30(T)(Not Included FPC)	mm
VIEWING AREA	60.00(W) x31.40(H)	mm
ACTIVE AREA	57.57(W) x 28.77(H)	mm
DOT SIZE	0.42(W) x 0.42(H)	mm
DOT PITCH	0.45(W) x 0.45(H)	mm
ASSY.TYPE	COG+FPC+BL	--
INTERFACE	6800/SPI	--
BACKLIGHT	White	--

1-4. MTBF

$$\begin{aligned}
 \text{MTBF} &= 500 * 10 * \exp\{(0.6/8.6 * 10E-5) * [(1/298) - (1/353)]\} / 2.30 \\
 &= 5000 * 38.39 / 2.30 \\
 &= 83452H
 \end{aligned}$$

STANDARD DOC.	PRODUCT SPEC.	MODULE NO.	S69508-DB025MB	PAGE	5/27
---------------	---------------	------------	----------------	------	------

2. BLOCK DIAGRAM

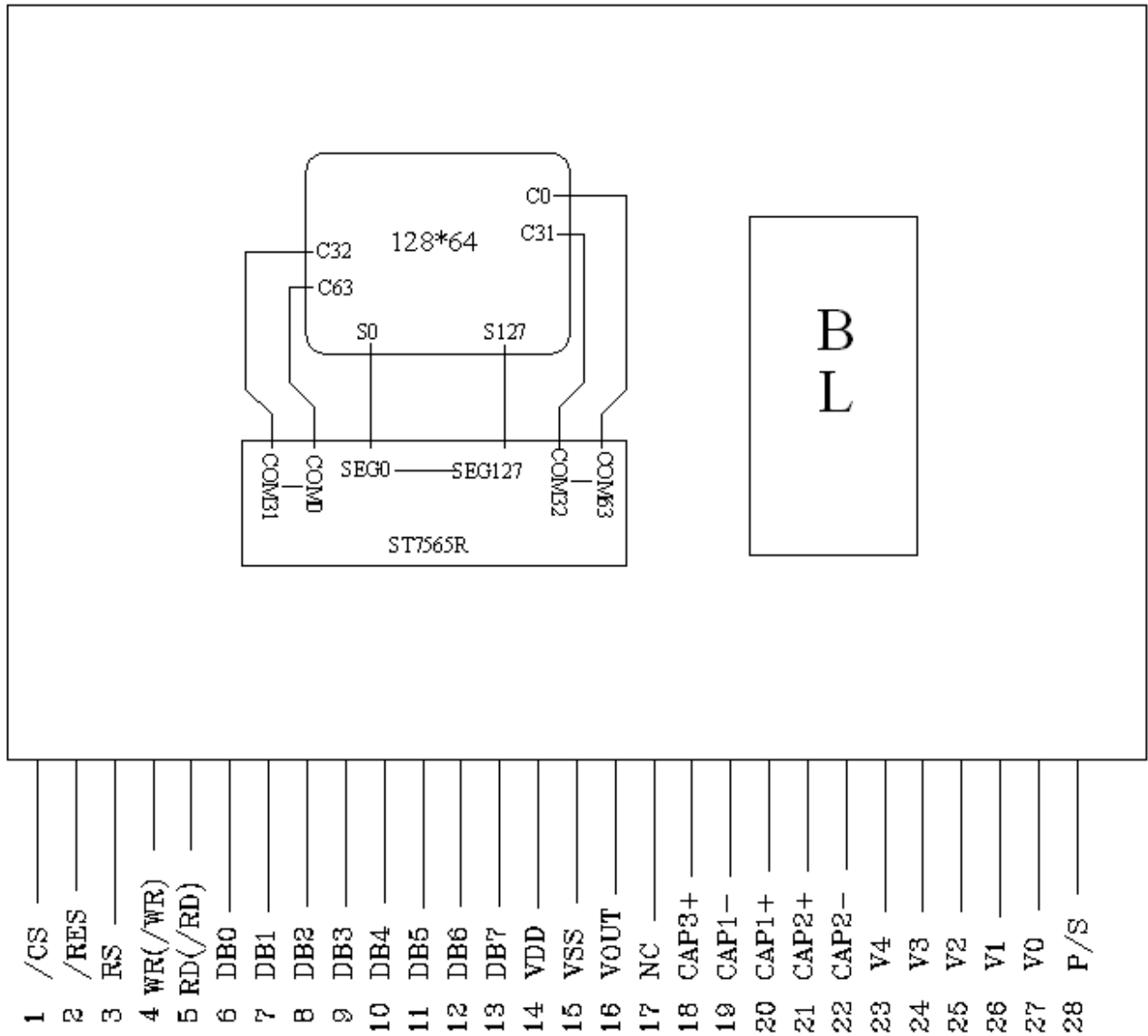

STANDARD DOC.	PRODUCT SPEC.	MODULE NO.	S69508-DB025MB	PAGE	6/27
---------------	---------------	------------	----------------	------	------

3.OUTLINE DRAWING

NOTE:

- GENERAL TOLERANCE: ±0.20.
- (...) IS REFERENCE DIMENSION.
- * CRITICAL DIMENSION
- Backlight lifetime at 25°C (If ≤ 75 mA) min 50K hrs
- Backlight luminance is 65cd/m² typ (@75mA)
- ROHS COMPLIANT

* Not to use the substances and their applications of SUCCESS Management Standard for Environment-related Substances to be Controlled*

Dimensions: 61.65, 2.75, 48.15 (BL), 46.00 (LCD/L), 36.00 (LCD/S), 31.40 MIN (V.A), 28.77 (A.A), 65.00 (LCD), 60.00 MIN (V.A), 57.57 (A.A), 1.08, 3.38, 4.39, 1.08, 3.58, 4.79, 1.08, 67.15 (BL), 128x64 DOTS, Viewing Direction, Pull tape, Stiffener, Silicon, Contact side, AU Plating, 9.75, 5.00±0.5, 10.70, 16.00±0.5, 14.50, 26.33±0.5, 13.25, 28, 4.30, 3.00±0.5, 2.90 MAX, 5.30 MAX, 10.00±1.0, 65.20±1.0, 0.05mm D.S.T, 4.00±0.3, 1, 28, 0.5*(28-1)=13.50±0.1, 0.45, 0.42, 0.4, 0.4

COM&SEG LAYOUT

DOTS DETAIL:101

BL CIRCUIT DIAGRAM (5 PCS White LED)

PN1	Description
1	1 /CS
2	RES
3	R3
4	WR/WR
5	RD/RD
6	DB0
7	DB1
8	DB2
9	DB3
10	DB4
11	DB5
12	DB6
13	DB7
14	VDD
15	VSS
16	VOUT
17	NC
18	CAP3+
19	CAP1+
20	CAP1-
21	CAP2+
22	CAP2-
23	V4
24	V3
25	V2
26	V1
27	V0
28	P/S

Display Type	STN BLUE
Operating Method	NEGATIVE
Viewing Angle	TRANSMISSIVE
LCD Driver IC	1/65 DUTY/1/9 BIAS
Interface	12 D/CLOCK
Operating Voltage	S1756SR
Driver Voltage	6800/SPI
Operation Temperature	Vop=8.3V
Storage Temperature	V01=9.3V
Connect Method	30C TD +20°C
	30C TD +80°C
	PC

DRAWN	ZHANGCHAO	TITLE	MODULE SPEC.
EE CHECKED	JIANGJIEQIANG	STR-S69508-DB025MB	
ME CHECKED	JIANGJIEQIANG	BOM NO.: BMT41201-01A	
APPROVED	HUJINBO	3rd Angle	
CUSTOMER'S APPROVAL			

VER.	SYMBOL	AMENDMENT	SIGN	DATE
01		first issue	ZHANGCHAO	15/09/22

SUCCESS ELECTRONICS LTD

STANDARD DOC.	PRODUCT SPEC.	MODULE NO.	S69508-DB025MB	PAGE	7/27
---------------	---------------	------------	-----------------------	------	------

4.INTERFACE ASSIGNMENT

1	Chip select input pin	/CS
2	Chip reset input pin	/RES
3	Chip data/instruction selection pin	RS
4	Read/Write signal select When R/W = "H": Read When R/W = "L": Write	WR(/WR)
5	Enable signal, start data read/write	RD(/RD)
6~13	8 bit data Bus Line	DB0~DB7
14	Logic power supply, +3.3V	VDD
15	Ground, 0V	VSS
16	DC/DC voltage converter. Connect a capacitor between this terminal and VSS or VDD	VOUT
17	NOT CONNECT	NC
18	DC/DC voltage converter. Connect a capacitor between this terminal and the CAP1-terminal	CAP3+
19	DC/DC voltage converter. Connect a capacitor between this terminal and the CAP1+terminal	CAP1-
20	DC/DC voltage converter. Connect a capacitor between this terminal and the CAP1-terminal	CAP1+
21	DC/DC voltage converter. Connect a capacitor between this terminal and the CAP2-terminal	CAP2+
22	DC/DC voltage converter. Connect a capacitor between this terminal and the CAP2+terminal	CAP2-
23		V4
24	LCD driver supply voltages.The voltage determined by LCD cell is Impedance converted by a resistive driver or an operation amplifier for application. Voltages should be the following relationship: $V0 \cong V1 \cong V2 \cong V3 \cong V4 \cong VSS$	V3
25		V2
26		V1
27		V0
28	This pin configures the interface to parallel mode or serial mode.	P/S

STANDARD DOC.	PRODUCT SPEC.	MODULE NO.	S69508-DB025MB	PAGE	8/27
---------------	---------------	------------	-----------------------	------	-------------

5.APPLICATION CIRCUIT

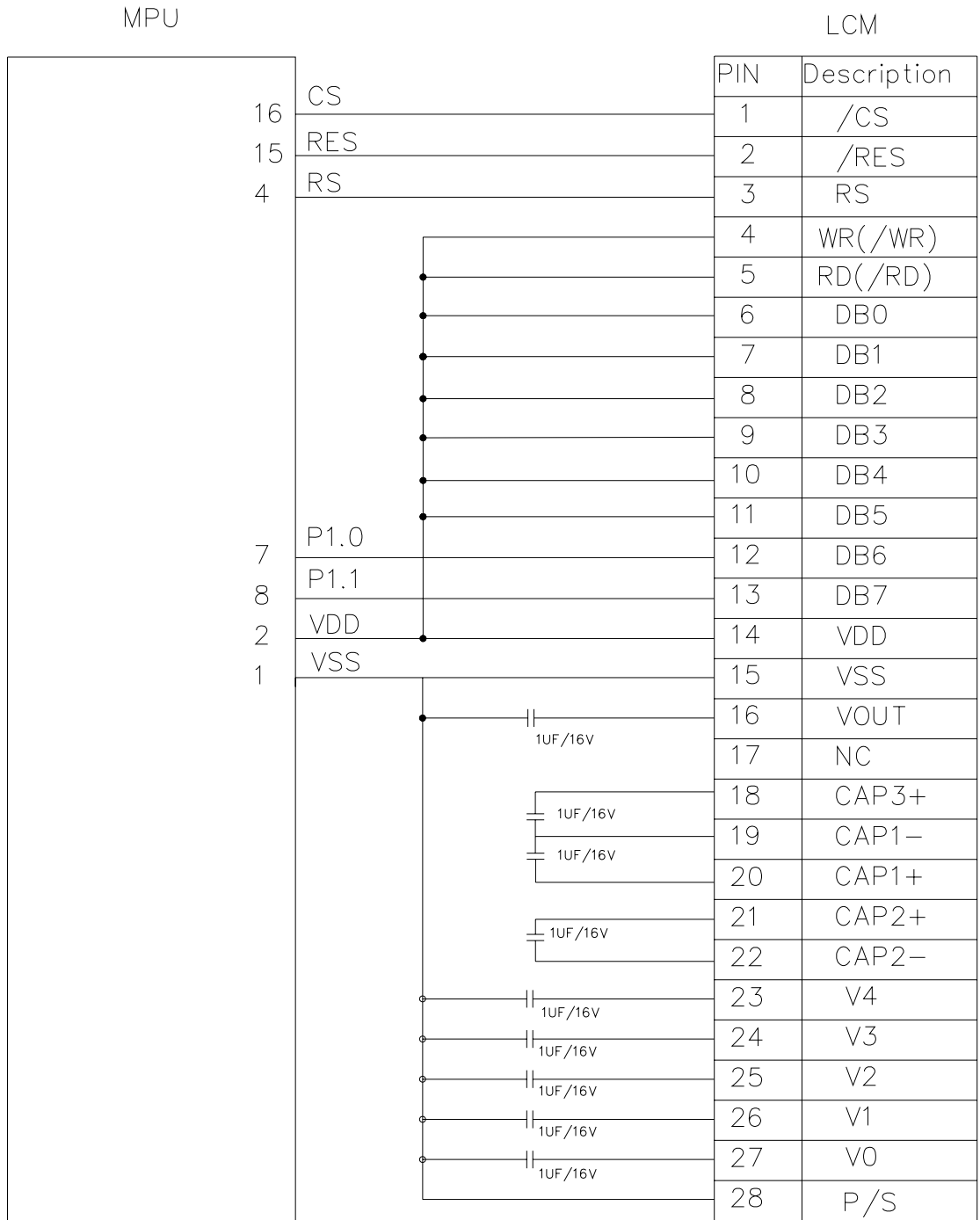

Remark: Applied to 4-Line SPI.

STANDARD DOC.	PRODUCT SPEC.	MODULE NO.	S69508-DB025MB	PAGE	9/27
---------------	---------------	------------	----------------	------	------

6. TIMING CHARACTERISTICS

6-1 For the 6800 series MPU(Default Mode)

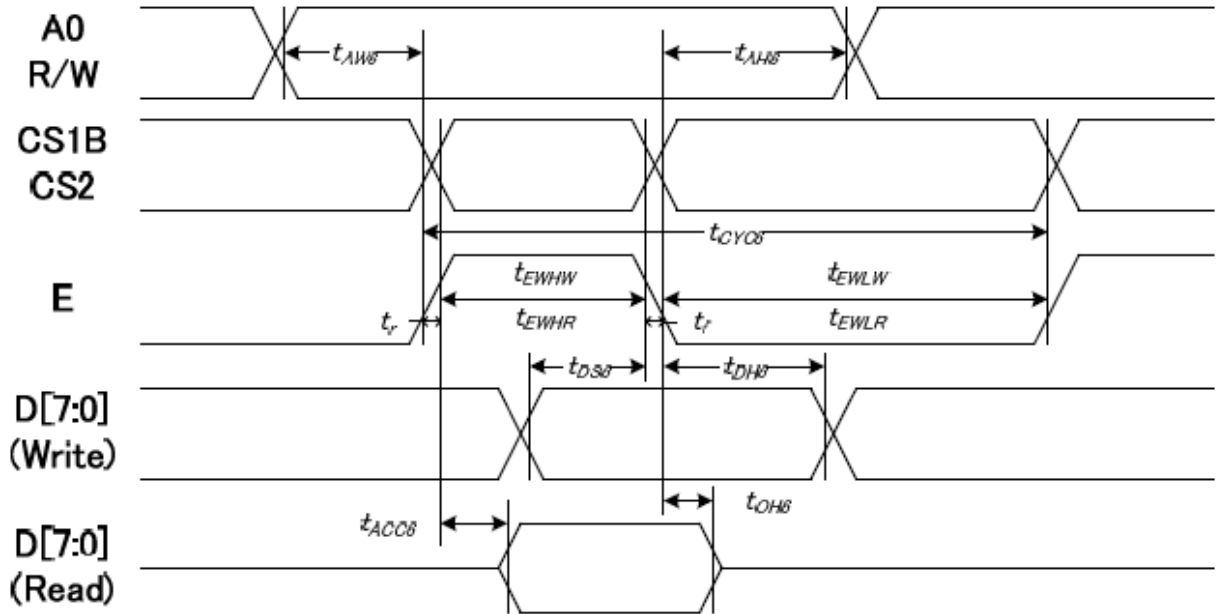

Item	Signal	Symbol	Condition	Min.	Max.	Unit
Address setup time	A0	tAW6		0	—	ns
Address hold time		tAH6		0	—	
System cycle time	E	tCYC6		240	—	
Enable L pulse width (WRITE)		tEHLW		80	—	
Enable H pulse width (WRITE)		tEHWL		80	—	
Enable L pulse width (READ)		tEHLR		80	—	
Enable H pulse width (READ)	tEHR		140	—		
Write data setup time	D[7:0]	tDSE6		40	—	
Write data hold time		tDHE6		10	—	
Read data access time		tACC6	CL = 100 pF	—	70	
Read data output disable time		tOHE6	CL = 100 pF	5	50	

STANDARD DOC.	PRODUCT SPEC.	MODULE NO.	S69508-DB025MB	PAGE	10/27
---------------	---------------	------------	-----------------------	------	--------------

6-2 For 4-Line Serial Interface

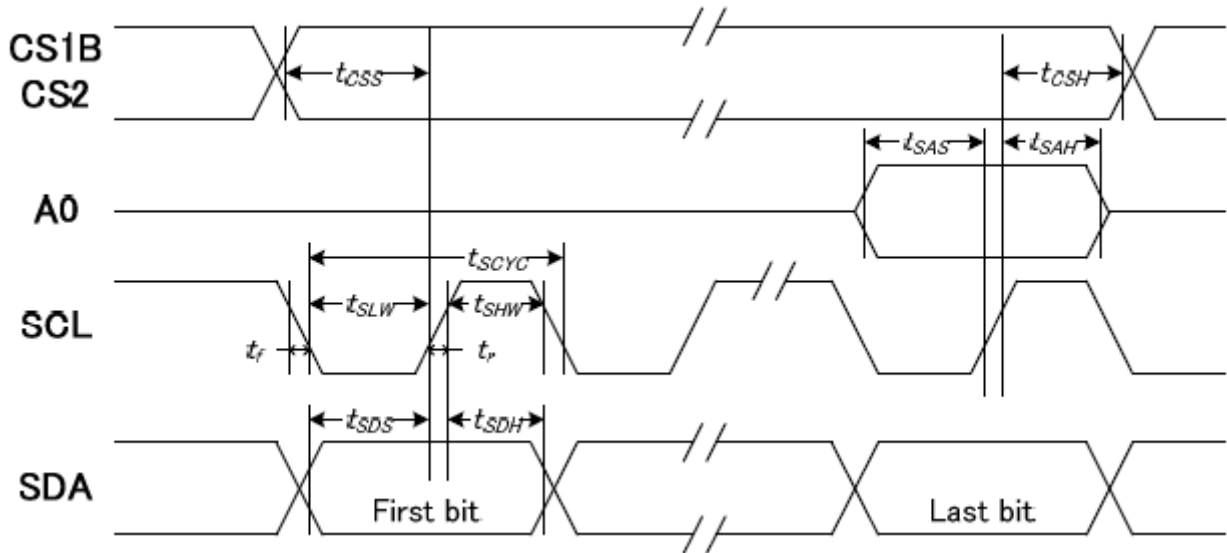

Item	Signal	Symbol	Condition	Min.	Max.	Unit
Serial clock period		tSCYC		50	—	ns
SCLK "H" pulse width	SCLK	tSHW		25	—	
SCLK "L" pulse width	SCLK	tSLW		25	—	
Address setup time	A0	tSAS		20	—	
Address hold time	A0	tSAH		10	—	
Data setup time	SDA	tSDS		20	—	
Data hold time	SDA	tSDH		10	—	
CS-SCLK time	CS1B	tCSS		20	—	
CS-SCLK time	CS2	tCSH		40	—	

STANDARD DOC.	PRODUCT SPEC.	MODULE NO.	S69508-DB025MB	PAGE	11/27
---------------	---------------	------------	-----------------------	------	--------------

6-3 RESET INPUT TIMING

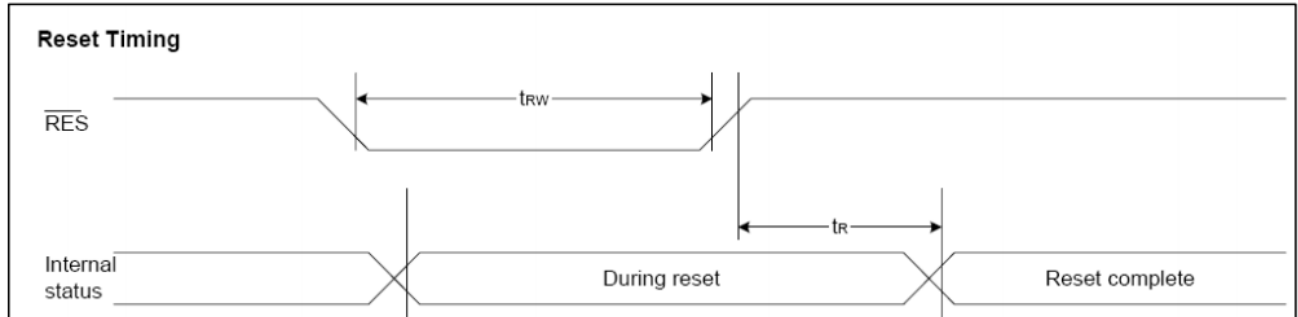

Item	Signal	Symbol	Condition	Rating			Units
				Min.	Typ.	Max.	
Reset time		t_r		—	—	1.0	us
Reset "L" pulse width	/RES	t_{rw}		1.0	—	—	us

STANDARD DOC.	PRODUCT SPEC.	MODULE NO.	S69508-DB025MB	PAGE	12/27
---------------	---------------	------------	----------------	------	-------

7. POWER ON/OFF SEQUENCE

(1)POWER ON:

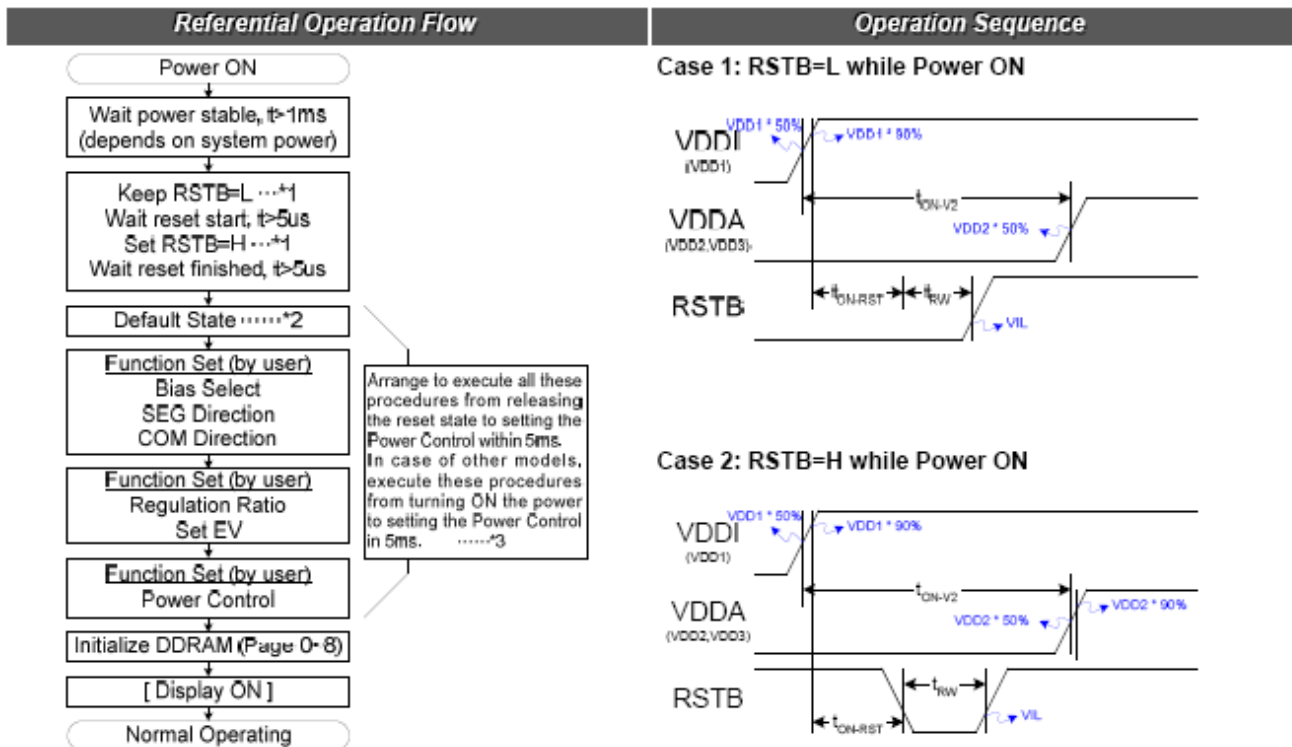

Note: The detailed description can be found in the respective sections listed below.

1. Please refer to the timing specification of t_{RW} and t_R .
2. Refer to Section RESET CIRCUIT.
3. The 5ms requirement depends on the characteristics of LCD panel and the external component of the power circuit. It is recommended to check with the real products with external component.
4. The detailed instruction functionality is described in Section INSTRUCTION DESCRIPTION;
5. Power stable is defined as the time that the later power (VDDI or VDDA) reaches 90% of its rated voltage.

Timing Requirement:

Item	Symbol	Requirement	Note
VDDA power delay	t_{ON-V2}	$0 \leq t_{ON-V2}$	<ul style="list-style-type: none"> Applying VDDI and VDDA in any order will not damage IC.
RSTB input time	t_{ON-RST}	No Limitation	<ul style="list-style-type: none"> If RSTB is Low, High or unstable during power ON, a successful hardware reset by RSTB is required after VDDI is stable. RSTB=L can be input at any time after power is stable. t_{RW} & t_R should match the timing specification of RSTB. To prevent abnormal display, the recommended timing is: $0 \leq t_{ON-RST} \leq 30 ms$.

- The requirement listed here is to prevent abnormal display on LCD module.

STANDARD DOC.	PRODUCT SPEC.	MODULE NO.	S69508-DB025MB	PAGE	13/27
---------------	---------------	------------	----------------	------	-------

(2)POWER OFF:

In power save mode, LCD outputs are fixed to VSS and all analog outputs are discharged. The power can be turned OFF after ST7565R is in the power save mode. The power save mode can be triggered by the following two methods.

Referential Power OFF Flow	Operation Sequence
----------------------------	--------------------

CASE 1: Use Power Save Instruction

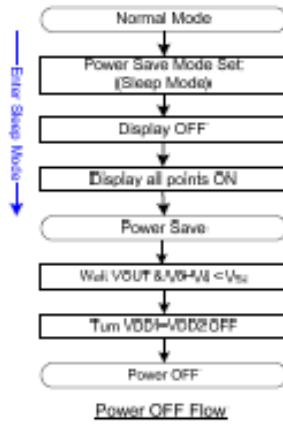

Instruction Flow

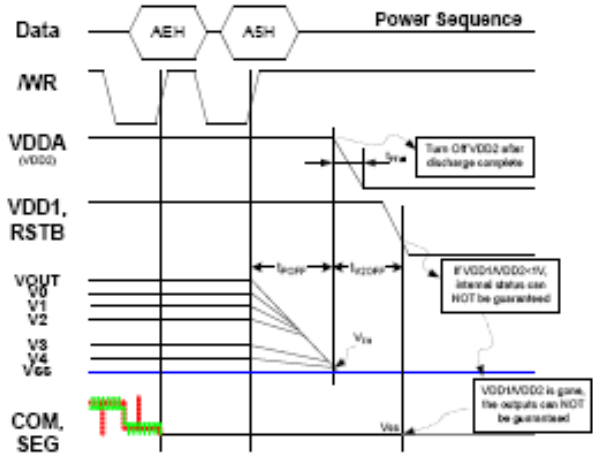

After the built-in power circuits are OFF and completely discharged (the power level of built-in analog circuit is smaller than V_{TH} of LCD panel), the power (VDD1, VDDA) can be removed. V_{TH} is around 0.2V to 1.0V.

CASE 2: Use Hardware Reset Function

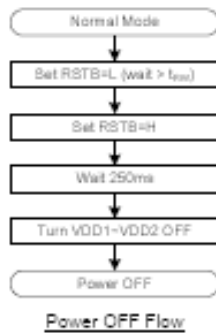

Instruction Flow

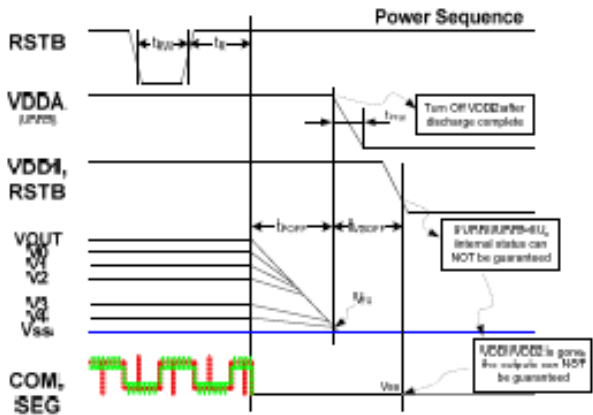

After the built-in power circuits are OFF and completely discharged (the power level of built-in analog circuit is smaller than V_{TH} of LCD panel), the power (VDD1, VDDA) can be removed. V_{TH} is around 0.2V to 1.0V.

Note:

1. t_{Doff} : Internal Power discharge time. Discharge time for built-in circuit is dependent on user's system design.
2. t_{2OFF} : Period between VDD1 and VDDA OFF time. => 0 ms (min).
3. It is NOT recommended to turn VDD1 OFF before VDDA. Without VDD1, the internal status cannot be guaranteed and internal discharge-process maybe stopped. The un-discharged power maybe flows into COM/SEG output(s) and the liquid crystal in panel maybe polarized.
4. IC will NOT be damaged if either VDD1 or VDDA is OFF while another is ON.
5. The timing is dependent on panel loading and the external capacitor(s).

STANDARD DOC.	PRODUCT SPEC.	MODULE NO.	S69508-DB025MB	PAGE	14/27
------------------	------------------	---------------	-----------------------	------	--------------

8. RECOMMENDED INITIAL CODES

```

void Initial(void)
{
    writec(0xa2);          /* 1/9 bias */
    writec(0xe2);
    writec(0xa0);          /* ADC select , Normal */
    writec(0xc8);          /* Common output reverse */
    writec(0xa6);          /* normal display 1=on */
    writec(0x2c);
    writec(0x2e);
    writec(0x2f);          /* V/C off, V/R off, V/F on */

    writec(0xf8);          /***4 booster***/
    writec(0x00);
    writec(0x24);          /* internal resistor ratio */
    writec(0x81);          /* electronic volume mode set */
    writec(0x1C);          /* electronic volume */
    writec(0x40);          /* display start first line */
    writec(0xaf);          /* display on */
}

```

STANDARD DOC.	PRODUCT SPEC.	MODULE NO.	S69508-DB025MB	PAGE	15/27
---------------	---------------	------------	-----------------------	------	--------------

9.INSTRUCTION TABLE

INSTRUCTION	A0	R/W (RWR)	COMMAND BYTE								DESCRIPTION
			D7	D6	D5	D4	D3	D2	D1	D0	
Display ON/OFF	0	0	1	0	1	0	1	1	1	D	D=1, display ON D=0, display OFF
Set Start Line	0	0	0	1	S5	S4	S3	S2	S1	S0	Set display start line
Set Page Address	0	0	1	0	1	1	Y3	Y2	Y1	Y0	Set page address
Set Column Address	0	0	0	0	0	1	X7	X6	X5	X4	Set column address (MSB)
	0	0	0	0	0	0	X3	X2	X1	X0	Set column address (LSB)
Read Status	0	1	BUSY	MX	D	RST	0	0	0	0	Read IC Status
Write Data	1	0	D7	D6	D5	D4	D3	D2	D1	D0	Write display data to RAM
Read Data	1	1	D7	D6	D5	D4	D3	D2	D1	D0	Read display data from RAM
SEG Direction	0	0	1	0	1	0	0	0	0	MX	Set scan direction of SEG MX=1, reverse direction MX=0, normal direction
Inverse Display	0	0	1	0	1	0	0	1	1	INV	INV =1, inverse display INV =0, normal display
All Pixel ON	0	0	1	0	1	0	0	1	0	AP	AP=1, set all pixel ON AP=0, normal display
Bias Select	0	0	1	0	1	0	0	0	1	BS	Select bias setting 0=1/9; 1=1/7 (at 1/65 duty)
Read-modify-Write	0	0	1	1	1	0	0	0	0	0	Column address increment: Read:+0 , Write:+1
END	0	0	1	1	1	0	1	1	1	0	Exit Read-modify-Write mode
RESET	0	0	1	1	1	0	0	0	1	0	Software reset
COM Direction	0	0	1	1	0	0	MY	-	-	-	Set output direction of COM MY=1, reverse direction MY=0, normal direction
Power Control	0	0	0	0	1	0	1	VB	VR	VF	Control built-in power circuit ON/OFF
Regulation Ratio	0	0	0	0	1	0	0	RR2	RR1	RR0	Select regulation resistor ratio
Set EV	0	0	1	0	0	0	0	0	0	1	Double command!! Set electronic volume (EV) level
	0	0	0	0	EV5	EV4	EV3	EV2	EV1	EV0	
Power Save Mode Set	0	0	1	0	1	0	1	1	0	MD	MD=0, sleep mode MD=1, normal
	0	0	0	0	0	0	0	0	0	0	
Power Save	0	0	Compound Command								Display OFF + All Pixel ON
Set Booster	0	0	1	1	1	1	1	0	0	0	Double command!! Set booster level: BL[1:0]=(0,0), x2, x3, x4 BL[1:0]=(0,1), x5 BL[1:0]=(1,1), x6
	0	0	0	0	0	0	0	0	BL1	BL0	
NOP	0	0	1	1	1	0	0	0	1	1	No operation
Test	0	0	1	1	1	1	-	-	-	-	Do NOT use. Reserved for testing.

Note: Symbol "-" means this bit can be "H" or "L".

STANDARD DOC.	PRODUCT SPEC.	MODULE NO.	S69508-DB025MB	PAGE	16/27
---------------	---------------	------------	-----------------------	------	--------------

10.ELECTRICAL CHARACTERISTICS

10-1 Absolute maximum ratings

ITEM	SYMBOL	STANDARD VALUE			UNIT
		MIN	TYP	MAX	
SUPPLY VOLTAGE FOR LOGIC	VDD	-0.3	--	+3.6	V
LCD POWER SUPPLY VOLTAGE	VIN	-0.3	--	13.5	V
OPERATING TEMPERATURE	T _{OP}	-20	--	70	°C
STORAGE TEMPERATURE	T _{STG}	-30	--	80	°C

10-2 Electrical characteristics

ITEM	SYMBOL	CONDITIONS	STANDARD VALUE			UNIT
			MIN	TYP	MAX	
SUPPLY VOLTAGE FOR LOGIC	VDD	Ta= 25°C	3.2	3.3	3.4	V
SUPPLY VOLTAGE FOR LCD	V0-VSS		8.1	8.3	8.5	V
INPUT VOLTAGE "H" LEVEL	VIH		0.8VDD	-	VDD	V
INPUT VOLTAGE "L" LEVEL	VIL		VSS	-	0.2VDD	V
OUTPUT VOLTAGE "H" LEVEL	VOH		0.8VDD	-	VDD	V
OUTPUT VOLTAGE "L" LEVEL	VOL		VSS	-	0.2VDD	V
CURRENT CONSUMPTION (CHECKER)	IDD		-	0.5	1.0	mA
POWER CONSUMPTION (CHECKER)	PC		-	1.65	3.3	mW

STANDARD DOC.	PRODUCT SPEC.	MODULE NO.	S69508-DB025MB	PAGE	17/27
---------------	---------------	------------	-----------------------	------	--------------

11. LED BACKLIGHT

11-1 LED CIRCUIT:

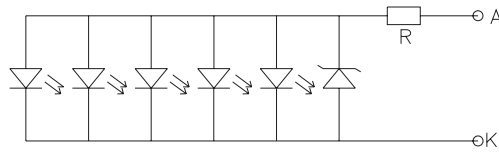

11-2.ABSOLUTE MAXIMUN RATING

PARAMETER	SYMBOL	SPECIFICATIONS	UNIT
POWER DISSIPATION	PD	400	mW
FORWARD CURRENT	Ifm	100	mA
PEAK FORWARD CURRENT	Ifp	300	mA
REVERSE VOLTAGE	Vr	5	V
OPERATION TEMPERATURE	TOPR	-20℃~+70℃	℃
STORAGE TEMPERATURE	TSTG	-30℃~+80℃	℃

11-3. ELECTRICAL CHARACTERISTICS (Ta=25℃)

PARAMETER	SYMBOL	LIGHT SOURCE	CONDITIONS	STANDARD VALUE			UNIT
				MIN	TYP	MAX	
FORWARD CURRENT	If	White	Vak=4.0V	-	75	100	mA
REVERSE CURRENT	IR		Vr= 5V/LED	-	-	10	uA
BL BRIGHTNESS	Lv		Vak=4.0V	800	1000	-	cd/m ²
CIE Color Coordinate(without LCD)	X		Vak=4.0V	0.24	0.27	0.30	-
	Y		Vak=4.0V	0.24	0.27	0.30	-
LUMINOUS UNIFORMITY	Δ		Vak=4.0V	75%	-	-	%.

Note: Uniformity Δ=(minmum LV/maximum LV)*100%.

For operation above 25℃, The Ifm、 Ifp & PD must be derated ,the Current derating is -0.36mA/℃ for Dc drive and-0.9mA/℃ for puls r drive,the power dissipation is -1.08 mW/℃ , The product working current must not more than the 60 % of the Ifp according to the working temperature.

STANDARD DOC.	PRODUCT SPEC.	MODULE NO.	S69508-DB025MB	PAGE	18/27
---------------	---------------	------------	----------------	------	-------

12. OPTICAL CHARACTERISTICS

Item	Symbol	Temp.	Condition	Min.	Typ.	Max.	Unit.	Note	
Response Time	Rise time	tr	-20°C	$\theta=0^\circ$ $\phi=0^\circ$	-	2100	2500	mS	-
			25°C		-	120	250		
			60°C		-	38	45		
	fall time	tf	-20°C		-	4400	5300		
			25°C		-	200	240		
			60°C		-	65	80		
Viewing Angle	θ	25°C Cr \geq 2	$\Phi=0^\circ$	-	30	-	deg.	-	
			$\Phi=90^\circ$	-	30	-			
			$\Phi=180^\circ$	-	30	-			
			$\Phi=270^\circ$	-	40	-			
Contrast Ratio	Cr	25°C	$\theta=\phi=0^\circ$	3	5	-	-	-	

(1) DEFINITION OF VIEWING ANGLE

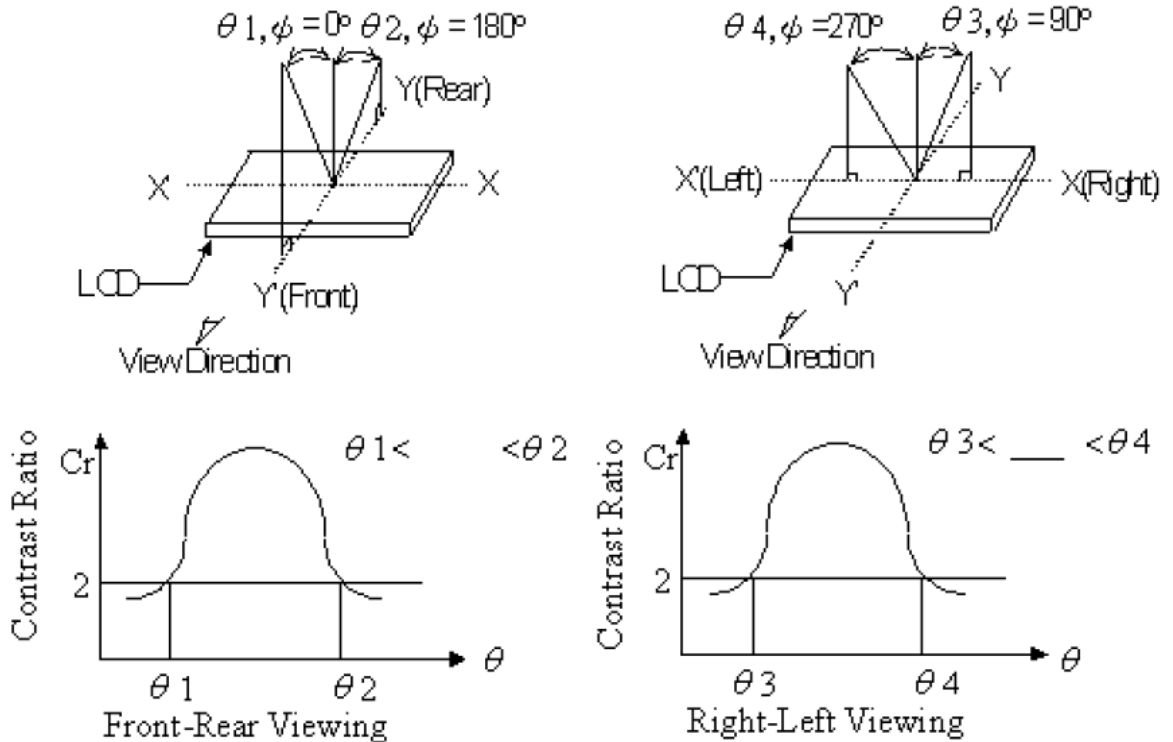

STANDARD DOC.	PRODUCT SPEC.	MODULE NO.	S69508-DB025MB	PAGE	19/27
---------------	---------------	------------	-----------------------	------	--------------

(2) DEFINITION OF CONTRAST

$$CR = \frac{\text{Brightness of non-selected segment (B2)}}{\text{Brightness of selected segment (B1)}}$$

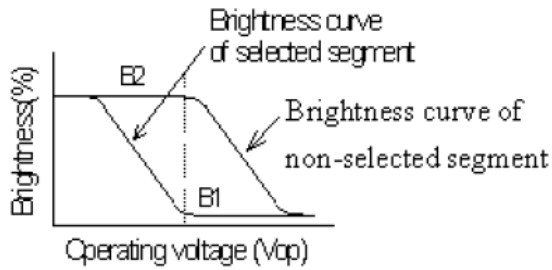

(3) DEFINITION OF RESPONSE

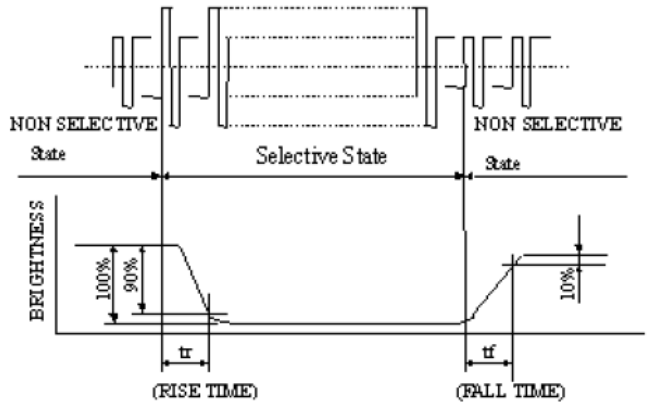

(4) MEASURING INSTRUMENTS FOR ELECTRO-OPTICAL CHARACTERISTICS

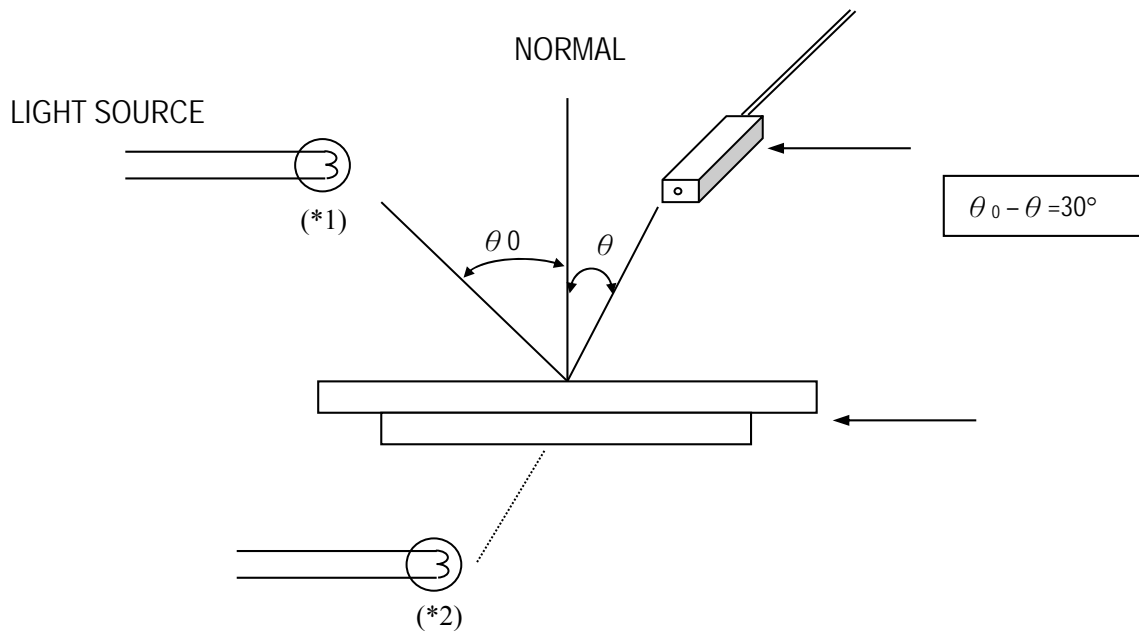

*1.Light source position for measuring the reflective type of LCD panel

*2.Light source position for measuring the transfective / transmissive types of LCD panel

STANDARD DOC.	PRODUCT SPEC.	MODULE NO.	S69508-DB025MB	PAGE	20/27
------------------	------------------	---------------	-----------------------	------	--------------

13. ENVIRONMENTAL ABSOLUTE MAXIMUM RATINGS

ITEM	SYMBOL	CONDITIONS	CRITERION
OPERATING TEMPERATURE	TOPR	-20°C ~ +70°C	NO DEFECT IN DISPLAYING AND OPERATIONAL FUNCTION
STORAGE TEMPERATURE	TSTG	-30°C ~ +80°C	NO DEFECT IN DISPLAYING AND OPERATIONAL FUNCTION
HUMIDITY	—	See Note	WITHOUT CONDENSATION

Note: Test condition:

1) Temperature and humidity: if no specification, temperature set at 25+/-2°C, and humidity set at 60+/-5% RH.

2) Operating state: all the tests to which the samples subject should be in operating condition.

14. RELIABILITY TEST

ITEM	CONDITIONS	CRITERION
Operating Temperature	HIGH TEMPERATURE 70°C 120HRS	No defect in displaying and operational function
	LOW TEMPERATURE -20°C 120HRS	
Storage Temperature	HIGH TEMPERATURE +80°C 120HRS	No defect in displaying and operational function
	LOW TEMPERATURE -30°C 120HRS	
High Humidity & high Temp	40°C * 90%RH 120HRS	No defect in displaying and operational function
Vibration	<ul style="list-style-type: none"> • Operating Time: 30 minutes exposure for each direction (X,Y,Z) • Sweep Frequency: 10~55Hz (1 min) • Amplitude: 1.5mm 	No defect in displaying and operational function
Thermal Shock	-20°C(30mins) ←→ +70°C(30mins) 50 cycles	No defect in displaying and operational function

STANDARD DOC.	PRODUCT SPEC.	MODULE NO.	S69508-DB025MB	PAGE	21/27
----------------------	----------------------	-------------------	-----------------------	-------------	--------------

15. THE STANDARD OF INSPECTION

15-1 SAMPLING PLAN

Unless there is other agreement, sampling plan for incoming inspection should follow GB2828-2003.

15-1-1 Lot size: Quantity per shipment as one lot (different model as different lot.)

15-1-2 Sampling type: Normal inspection, single sampling.

15-1-3 Sampling level: Level II.

15-1-4 Acceptable Quality Level

Major defect: AQL=0.40

Minor defect: AQL=0.65

Total defect : AQL=0.65

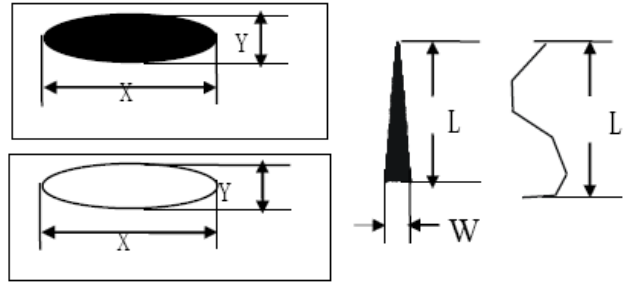

15-2 PANEL INSPECTION CONDITION

15-2-1 Environment: Room Temperature: $25 \pm 5^\circ\text{C}$. Humidity: $55 \pm 5\%$ RH. Illumination: 800~1200Lux.

15-2-2 Inspection Distance: 25 ± 5 cm from the inspector to the module.

15-2-3 Inspection Angle: The vision of inspector should be perpendicular to the surface of the module.

16-3 MODULE INSPECTION STANDARDS

16-3-1 Defect definition

MAJOR: display or functional defects, serious deviation from the specifications, customers can not work properly; Severe skin defects, serious deviation from the specifications, the client does not work properly.

MINOR: slightly deviate from the specifications, does not affect the product function, but the appearance of an impact on product

Note: The following standard if no entities are specified, with mm meter.

15-3-2 Product area and size code definition

A area: said display active area(characters display)

B area: says visual area (except A area)

C area: the unvisual areas.

T: it says the thickness of the single glass

L: said glass pin lengths

K: said product length

X :said glass long side direction or glass edge direction along the length of the gap

Y :said glass short side direction or gap with glass edge along the vertical length

Z: the thickness of crack or gap

15-3-2 Point, line definition

point: $\Phi = (X + Y) / 2$

The length of the X says point length; Y says point width

Line: L says the length of the line; W says line width

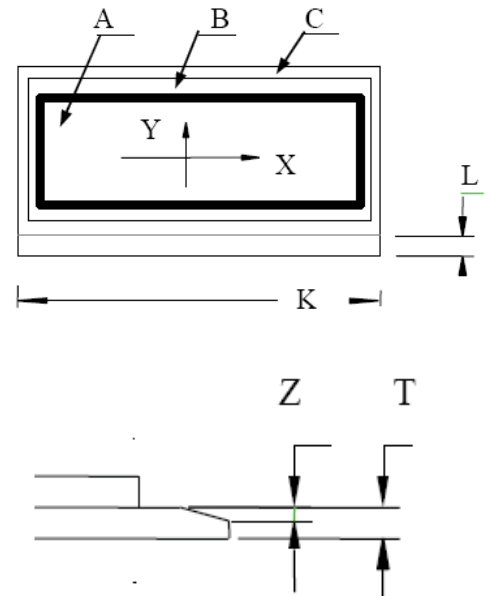

STANDARD DOC.	PRODUCT SPEC.	MODULE NO.	S69508-DB025MB	PAGE	22/27
---------------	---------------	------------	----------------	------	-------

15-3-3 Inspection items and specification for appearance(power off)

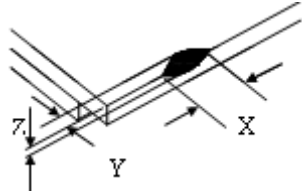
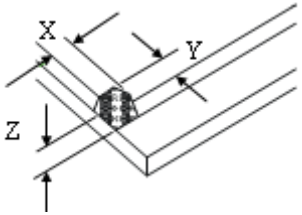
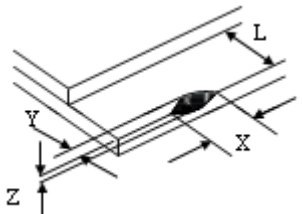
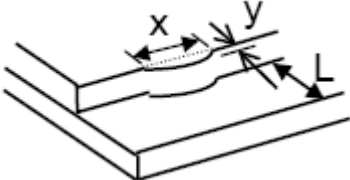
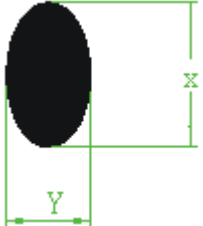
No.	Item	Criterion	AQL																						
1	Dimension	Dimension out of the specification	1.0																						
2	Glass crack	<p>1、 General crack</p>  <table border="1" data-bbox="874 436 1337 555"> <tr> <td>X</td> <td>Y</td> <td>Z</td> </tr> <tr> <td>$\geq K/8$</td> <td>Not over A area</td> <td>$\leq T$</td> </tr> </table> <p>2、 corner</p>  <table border="1" data-bbox="874 667 1337 786"> <tr> <td>X</td> <td>Y</td> <td>Z</td> </tr> <tr> <td>$\geq K/8$</td> <td>Not over A area</td> <td>No check</td> </tr> </table> <p>3、 contact pad crack</p>  <table border="1" data-bbox="874 925 1337 1010"> <tr> <td>X</td> <td>Y</td> <td>Z</td> </tr> <tr> <td>$\geq K/8$</td> <td>$\geq L/3$</td> <td>No check</td> </tr> </table> <p>4、 Substrate protuberance and internal crack</p>  <table border="1" data-bbox="909 1198 1252 1283"> <tr> <td>X</td> <td>Y</td> </tr> <tr> <td>$\geq K/8$</td> <td>$\geq L/3$</td> </tr> </table> <p>Transfer position crack: $\leq L/5$</p>	X	Y	Z	$\geq K/8$	Not over A area	$\leq T$	X	Y	Z	$\geq K/8$	Not over A area	No check	X	Y	Z	$\geq K/8$	$\geq L/3$	No check	X	Y	$\geq K/8$	$\geq L/3$	2.50
X	Y	Z																							
$\geq K/8$	Not over A area	$\leq T$																							
X	Y	Z																							
$\geq K/8$	Not over A area	No check																							
X	Y	Z																							
$\geq K/8$	$\geq L/3$	No check																							
X	Y																								
$\geq K/8$	$\geq L/3$																								
3	Black dot \ White dot	 <table border="1" data-bbox="750 1433 1337 1680"> <thead> <tr> <th rowspan="2">D</th> <th colspan="2">Acceptable of defect</th> </tr> <tr> <th>A/B Area</th> <th>C Area</th> </tr> </thead> <tbody> <tr> <td>$D < 0.2$</td> <td colspan="2">No check</td> </tr> <tr> <td>$0.2 \leq D < 0.3$</td> <td>2</td> <td rowspan="3">No check</td> </tr> <tr> <td>$0.3 \leq D \leq 0.5$</td> <td>1</td> </tr> <tr> <td>$D > 0.5$</td> <td>0</td> </tr> </tbody> </table> <p>X: long diameter Y: shot diameter D: average of diameter $D=(X+Y)/2$</p>	D	Acceptable of defect		A/B Area	C Area	$D < 0.2$	No check		$0.2 \leq D < 0.3$	2	No check	$0.3 \leq D \leq 0.5$	1	$D > 0.5$	0	2.50							
D	Acceptable of defect																								
	A/B Area	C Area																							
$D < 0.2$	No check																								
$0.2 \leq D < 0.3$	2	No check																							
$0.3 \leq D \leq 0.5$	1																								
$D > 0.5$	0																								

STANDARD DOC.	PRODUCT SPEC.	MODULE NO.	S69508-DB025MB	PAGE	23/27
---------------	---------------	------------	----------------	------	-------

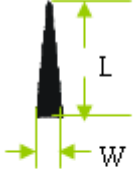
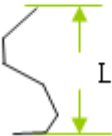
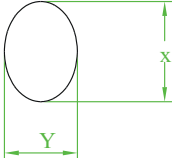
4	Line defect	  L: Length W: Width Defect of polarizer (Scratches、Spot) : According to the limit specimen	<table border="1"> <thead> <tr> <th rowspan="2">Length</th> <th rowspan="2">width</th> <th colspan="2">Acceptable of defect</th> </tr> <tr> <th>A/B Area</th> <th>C Area</th> </tr> </thead> <tbody> <tr> <td>accept</td> <td>$W \leq 0.02$</td> <td>No check</td> <td rowspan="2">No check</td> </tr> <tr> <td>$L \leq 3$</td> <td>$W \leq 0.05$</td> <td>2</td> </tr> <tr> <td rowspan="2">$L \leq 2.5$</td> <td>$W \leq 0.05$</td> <td>2</td> <td rowspan="2">As round type</td> </tr> <tr> <td>$W > 0.05$</td> <td></td> </tr> </tbody> </table>	Length	width	Acceptable of defect		A/B Area	C Area	accept	$W \leq 0.02$	No check	No check	$L \leq 3$	$W \leq 0.05$	2	$L \leq 2.5$	$W \leq 0.05$	2	As round type	$W > 0.05$		2.50
Length	width	Acceptable of defect																					
		A/B Area	C Area																				
accept	$W \leq 0.02$	No check	No check																				
$L \leq 3$	$W \leq 0.05$	2																					
$L \leq 2.5$	$W \leq 0.05$	2	As round type																				
	$W > 0.05$																						
5	Polarizer Bubble		<table border="1"> <thead> <tr> <th rowspan="2">D</th> <th colspan="2">Acceptable of defect</th> </tr> <tr> <th>A/B Area</th> <th>C Area</th> </tr> </thead> <tbody> <tr> <td>$D \leq 0.2$</td> <td>No check</td> <td rowspan="3">No check</td> </tr> <tr> <td>$0.2 \leq D \leq 0.5$</td> <td>3</td> </tr> <tr> <td>$0.5 \leq D \leq 1.0$</td> <td>2</td> </tr> <tr> <td>$D > 1.0$</td> <td>0</td> <td></td> </tr> </tbody> </table>	D	Acceptable of defect		A/B Area	C Area	$D \leq 0.2$	No check	No check	$0.2 \leq D \leq 0.5$	3	$0.5 \leq D \leq 1.0$	2	$D > 1.0$	0		2.50				
D	Acceptable of defect																						
	A/B Area	C Area																					
$D \leq 0.2$	No check	No check																					
$0.2 \leq D \leq 0.5$	3																						
$0.5 \leq D \leq 1.0$	2																						
$D > 1.0$	0																						
6	External print of panel	Transfigure、 pin hole: same as segment transfiguer Print width: print width $\geq 1/2$ standard width is acceptable		2.50																			
7	Silicon glue	The area of painting silicon glue must cover the ITO circuit.		2.50																			
8	Defect of PCB	The char、 wrong edition、 bresking off circuit、 crack and air-logged orifice are unreceivable for PCB. gold finger of PCB can not be oxidative、 smudgy and broken..		2.50																			
9	SMT organ	deflexion of component $\leq 1/3$ width of component Trying to keep dot of soldering tin orbicular Damage、 break、 wrong assembly and unseal are unreceivable for component.		2.50																			
10	Steel Frame	Break and distortion are unreceivable for frame. If there is one nick which can not lead to cast or hole of painting, we allow that following: Length ≤ 5 mm; Width ≤ 0.3 mm		2.50																			

15-3-4 Inspection items and specification for display defect(power on)

1	Electrical Defect	Segment missing	Not allow	1.0
		Segment sort	Not allow	
		Non-display	Not allow	

STANDARD DOC.	PRODUCT SPEC.	MODULE NO.	S69508-DB025MB	PAGE	24/27
---------------	---------------	------------	-----------------------	------	--------------

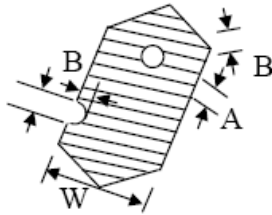
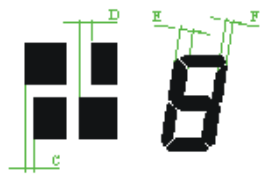
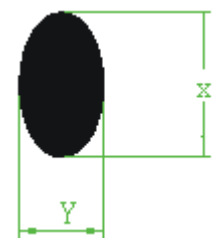
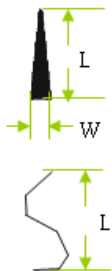
2	Pin hole	<p>1、Pin hole</p>  <table border="1"> <tr> <th>width</th> <th>Acceptable of defect</th> </tr> <tr> <td>$W < 0.4$</td> <td>$D \leq 0.2$ & $D \leq 1/2W$</td> </tr> <tr> <td>$W \geq 0.4$</td> <td>$D \leq 0.25$ & $D \leq 1/3W$</td> </tr> </table> <p>* $D = (A+B)/2$ $D \leq 0.1$ acceptable</p>	width	Acceptable of defect	$W < 0.4$	$D \leq 0.2$ & $D \leq 1/2W$	$W \geq 0.4$	$D \leq 0.25$ & $D \leq 1/3W$	2.50															
width	Acceptable of defect																							
$W < 0.4$	$D \leq 0.2$ & $D \leq 1/2W$																							
$W \geq 0.4$	$D \leq 0.25$ & $D \leq 1/3W$																							
3	Display pattern	 <table border="1"> <tr> <th>Width</th> <th>Acceptable of defect</th> </tr> <tr> <td>$W < 0.4$</td> <td>$C, D, G \leq 1/2W$</td> </tr> <tr> <td>$W \geq 0.4$</td> <td>$C, D, G \leq 0.2$</td> </tr> </table> <p>W: Design dimension C、D: discrepant dimension $G = E-F$</p>	Width	Acceptable of defect	$W < 0.4$	$C, D, G \leq 1/2W$	$W \geq 0.4$	$C, D, G \leq 0.2$	1.0															
Width	Acceptable of defect																							
$W < 0.4$	$C, D, G \leq 1/2W$																							
$W \geq 0.4$	$C, D, G \leq 0.2$																							
4	Black/white dot	 <table border="1"> <tr> <th rowspan="2">D</th> <th colspan="2">Acceptable QTY</th> </tr> <tr> <th>A/B Area</th> <th>C Area</th> </tr> <tr> <td>$D < 0.1$</td> <td colspan="2">No check</td> </tr> <tr> <td>$0.1 \leq D < 0.2$</td> <td>2</td> <td rowspan="2">No check</td> </tr> <tr> <td>$0.2 \leq D \leq 0.25$</td> <td>1</td> </tr> <tr> <td>$D > 0.25$</td> <td colspan="2">0</td> </tr> </table> <p>X: long diameter Y: shot diameter D: average diameter $D = (X+Y)/2$</p>	D	Acceptable QTY		A/B Area	C Area	$D < 0.1$	No check		$0.1 \leq D < 0.2$	2	No check	$0.2 \leq D \leq 0.25$	1	$D > 0.25$	0		2.50					
D	Acceptable QTY																							
	A/B Area	C Area																						
$D < 0.1$	No check																							
$0.1 \leq D < 0.2$	2	No check																						
$0.2 \leq D \leq 0.25$	1																							
$D > 0.25$	0																							
5	Line defect	 <table border="1"> <tr> <th rowspan="2">Length</th> <th rowspan="2">Width</th> <th colspan="2">Acceptable QTY</th> </tr> <tr> <th>A/B Area</th> <th>C Area</th> </tr> <tr> <td>不计</td> <td>$W \leq 0.02$</td> <td colspan="2">No check</td> </tr> <tr> <td>$L \leq 3$</td> <td>$W \leq 0.03$</td> <td>2</td> <td rowspan="2">No check</td> </tr> <tr> <td rowspan="2">$L \leq 2.5$</td> <td>$0.03 < W \leq 0.05$</td> <td>2</td> </tr> <tr> <td></td> <td>$W > 0.05$</td> <td colspan="2">Sa round type</td> </tr> </table> <p>L: length W: width</p>	Length	Width	Acceptable QTY		A/B Area	C Area	不计	$W \leq 0.02$	No check		$L \leq 3$	$W \leq 0.03$	2	No check	$L \leq 2.5$	$0.03 < W \leq 0.05$	2		$W > 0.05$	Sa round type		2.50
Length	Width	Acceptable QTY																						
		A/B Area	C Area																					
不计	$W \leq 0.02$	No check																						
$L \leq 3$	$W \leq 0.03$	2	No check																					
$L \leq 2.5$	$0.03 < W \leq 0.05$	2																						
		$W > 0.05$	Sa round type																					

16. USING LCD MODULES

16-1 LIQUID CRYSTAL DISPLAY MODULES

LCD is composed of glass and polarizer. Pay attention to the following items when handling.

- (1) Please keep the temperature within specified range for use and storage. Polarization degradation, bubble generation or polarizer peel-off may occur with high temperature and high humidity.

STANDARD DOC.	PRODUCT SPEC.	MODULE NO.	S69508-DB025MB	PAGE	25/27
------------------	------------------	---------------	-----------------------	------	--------------

- (2) Do not touch, push or rub the exposed polarizer with anything harder than an HB pencil lead (glass, tweezers, etc.).
- (3) N-hexane is recommended for cleaning the adhesives used to attach front/rear polarizers and reflectors made of organic substances which will be damaged by chemicals such as acetone, toluene, ethanol and isopropylalcohol.
- (4) If the display surface becomes contaminated, breathe on the surface and gently wipe it with a soft dry cloth. If it is heavily contaminated, wipe gently with absorbent cotton or other soft material like chamois soaked in Isopropyl alcohol or Ethyl alcohol. Do not scrub hard to avoid damaging the display surface.
- (5) Wipe off saliva or water drops immediately, contact with water over a long period of time may cause deformation or color fading.
- (6) Avoid contacting oil and fats.
- (7) Condensation on the surface and contact with terminals due to cold will damage, stain or dirty the polarizers. After products are tested at low temperature they must be warmed up in a container before coming is contacting with room temperature air.
- (8) Do not put or attach anything on the display area to avoid leaving marks on.
- (9) Do not touch the display with bare hands. This will stain the display area and degradate insulation between terminals (some cosmetics are determinated to the polarizers).
- (10) Exercise care to minimize corrosion of the electrode. Corrosion of the electrodes is accelerated by water droplets, moisture condensation or a current flow in a high-humidity environment.
- (11) As glass is fragile. It tends to become or chipped during handling especially on the edges. Please avoid dropping or jarring.

16-2 PRECAUTION FOR HANDING LCD MODULES

Since LCM has been assembled and adjusted with a high degree of precision, avoid applying excessive shocks to the module or making any alterations or modifications to it.

- (1) Do not alter, modify or change the the shape of the tab on the metal frame.
- (2) Do not make extra holes on the printed circuit board, modify its shape or change the positions of components to be attached.
- (3) Do not damage or modify the pattern writing on the printed circuit board.
- (4) Absolutely do not modify the zebra rubber strip (conductive rubber) or heat seal connector.
- (5) Except for soldering the interface, do not make any alterations or modifications with a soldering iron.
- (6) Do not drop, bend or twist LCM. In particular, do not forcibly pull or bend the I/O cable or the backlight cable.
- (7) In order to avoid the cracking of the FPC,you should to pay attention to the area of FPC where the FPC was bent .the edge of coverlay;the area of surface of Ni-Au plating,the area of soldering land,the area of through hole.

16-3 ELECTRO-STATIC DISCHARGE CONTROL

Since this module uses a CMOS LSI, the same careful attention should be paid to electrostatic discharge as for an ordinary CMOS IC.

STANDARD DOC.	PRODUCT SPEC.	MODULE NO.	S69508-DB025MB	PAGE	26/27
---------------	---------------	------------	-----------------------	------	--------------

- (1) Make certain that you are grounded when handing LCM. To minimize the performance degradation of the LCD modules resulting from destruction caused by static electricity etc., exercise care to avoid holding the following sections when handling the modules.
 - Exposed area of the printed circuit board.
 - Terminal electrode sections.
- (2) Before remove LCM from its packing case or incorporating it into a set, be sure the module and your body have the same electric potential.
- (3) When soldering the terminal of LCM, make certain the AC power source for the soldering iron does not leak.
- (4) When using an electric screwdriver to attach LCM, the screwdriver should be of ground potentiality to minimize as much as possible any transmission of electromagnetic waves produced sparks coming from the commutator of the motor.
- (5) As far as possible make the electric potential of your work clothes and that of the work bench the ground potential.
- (6) To reduce the generation of static electricity be careful that the air in the work is not too dried. A relative humidity of 50%-60% is recommended.

16-4 PRECAUTIONS FOR OPERATION

- (1) Viewing angle varies with the change of liquid crystal driving voltage (VO). Adjust VO to show the best contrast.
- (2) Driving the LCD in the voltage above the limit shortens its life.
- (3) If the LCD modules have been operating for a long time showing the same display patterns, the display patterns may remain on the screen as ghost images and a slight contrast irregularity may also appear. A normal operating status can be regained by suspending use for some time. It should be noted that this phenomenon does not adversely affect performance reliability.
- (4) Response time is greatly delayed at temperature below the operating temperature range. However, this does not mean the LCD will be out of the order. It will recover when it returns to the specified temperature range.
- (5) If the display area is pushed hard during operation, the display will become abnormal. However, it will return to normal if it is turned off and then back on.
- (6) Condensation on terminals can cause an electrochemical reaction disrupting the terminal circuit. Therefore, it must be used under the relative condition of 40°C , 50% RH.
- (7) When turning the power on, input each signal after the positive/negative voltage becomes stable.

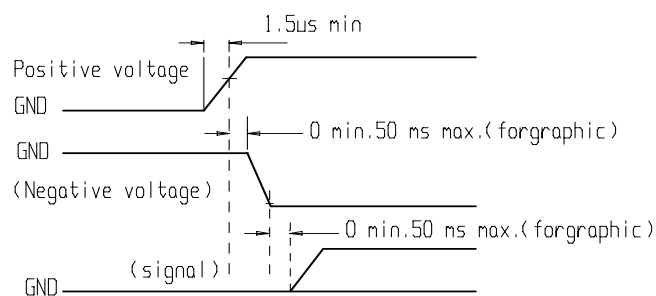

STANDARD DOC.	PRODUCT SPEC.	MODULE NO.	S69508-DB025MB	PAGE	27/27
------------------	------------------	---------------	-----------------------	------	--------------

16-5 STORAGE

When storing LCDs as spares for some years, the following precaution are necessary.

- (1) Store them in a sealed polyethylene bag. If properly sealed, there is no need for dessicant.
- (2) Store them in a dark place. Do not expose to sunlight or fluorescent light, keep the temperature between 0°C and 35°C.
- 3) The polarizer surface should not come in contact with any other objects. (We advise you to store them in the container in which they were shipped.)
- (4) Environmental conditions :
 - Do not leave them for more than 180hrs. at 70°C.
 - Should not be left for more than 48hrs. at -20°C.

16-6 SAFETY

- (1) It is recommended to crush damaged or unnecessary LCDs into pieces and wash them off with solvents such as acetone and ethanol, which should later be burned.
- (2) If any liquid leaks out of a damaged glass cell and comes in contact with the hands, wash off thoroughly with soap and water.

14-7 LIMITED WARRANTY

Unless agreed between SUCCESS and customer, SUCCESS will replace or repair any of its LCD modules which are found to be functionally defective when inspected in accordance with SUCCESS LCD acceptance standards (copies available upon request) for a period of one year from date of shipments. Cosmetic/visual defects must be returned to SUCCESS within 90 days of shipment. Confirmation of such date shall be based on freight documents. The warranty liability of SUCCESS limited to repair and/or replacement on the terms set forth above. SUCCESS will not be responsible for any subsequent or consequential events.

16-8 RETURN LCM UNDER WARRANTY

No warranty can be granted if the precautions stated above have been disregarded. The typical examples of violations are :

- Broken LCD glass.
- Circuit modified in any way, including addition of components.

Module repairs will be invoiced to the customer upon mutual agreement. Modules must be returned with sufficient description of the failures or defects. Any connectors or cable installed by the customer must be removed completely without damaging the PCB's eyelet, conductors and terminals.