

# DATA IMAGE CORPORATION

## CTP Module Specification

PRELIMINARY

ITEM NO.: SCF0500133GGU19

### Table of Contents

1. COVER & CONTENTS .....	1
2. RECORD OF REVISION .....	2
3. GENERAL SPECIFICATIONS .....	3
4. LCD ABSOLUTE MAXIMUM RATINGS.....	3
5. LCD ELECTRICAL CHARACTERISTICS .....	3
6. LCD TIMING CHARACTERISTICS .....	5
7. BLOCK DIAGRAM.....	7
8. LCD PIN CONNECTIONS .....	8
9. OPTICAL CHARACTERISTIC .....	10
10. CTP SPECIFICATIONS .....	13
11. CTP REGISTERS .....	15
12. APPEARANCE SPECIFICATION .....	22
13. QUALITY ASSURANCE .....	25
14. LCM PRODUCT LABEL DEFINE .....	26
15. PRECAUTIONS IN USE LCM .....	28
16. OUTLINE DRAWING .....	29
17. PACKAGE INFORMATION .....	30

Customer Companies	R&D Dept.	Q.C. Dept.	Eng. Dept.	Prod. Dept.
	ALEX	JOE	GARY	KEN
Approved by	Version:	Issued Date:	Sheet Code:	Total Pages:
	1	24/NOV/14'		30



### 3. GENERAL SPECIFICATIONS

Composition: 5 inch WVGA resolution display with a projected Capacitive Touch Panel (CTP).  
Interface : RGB Interface for panel and I<sup>2</sup>C for the CTP.

No.	Item	Specification	Unit
1	LCD size	5.0 (Diagonal)	inch
2	Outline Dimension	142(W) x 94(H) x 6.25(D)	mm
3	LCD Active Area	108(W) x 64.8(H)	mm
4	Sensor Active Area	108.8(W) x 65.6(H)	mm
5	Number of Pixel	800(H) x (RGB) x 480 (V)	pixels
6	Pixel pitch	0.135(H) x 0.135(V)	mm
7	Display mode	Normally white	
8	LCM model number	FG0500A0DSSWBGL1	
9	Weight	TBD	g
10	Back-light	LED Side-light type	
11	View direction	6:00	

Remark: Our components and processes are compliant to RoHS standard.

### 4. LCD ABSOLUTE MAXIMUM RATINGS

Parameter	Symbol	MIN.	MAX.	Unit	Remark
Power supply voltage	VDD	-0.5	5.0	V	GND = 0V
Input signal voltage	Logic input	-0.3	VDD+0.3	V	
Operating temperature	Topa	-20	70	°C	
Storage temperature	Tstg	-30	80	°C	

### 5. LCD ELECTRICAL CHARACTERISTICS

#### 5.1 Typical operation conditions

T<sub>a</sub> = 25°C

Parameter	Symbol	MIN.	Typ.	MAX.	Unit	Remark
Power Supply voltage	VDD	3.0	3.3	3.6	V	
Input signal voltage	V <sub>IH</sub>	0.7*VDD	--	VDD	V	Note 1
	V <sub>IL</sub>	GND	--	0.3*VDD	V	
Current of Power Supply	IDD	--	--	220	mA	VDD = 3.3V

Note:(1) HSYNC, VSYNC, DE, R/G/B Data (2) GND = 0V

## 5.2 Backlight Unit

The backlight system is an edge-lighting type with 18 LED

The characteristics of the LED are shown in the following tables.

$T_a = 25\text{ }^\circ\text{C}$

Parameter	Symbol	Min	Typ.	Max.	Unit	Remark
LED voltage	$V_L$	9	9.6	10.2	V	
LED current	$I_L$	--	120	--	mA	
Operating LED Life Time		10000	--	--	Hour	Note(1)

Note 1: The "LED life time" is defined as the module brightness decrease to 50% original brightness at  $T_a=25\text{ }^\circ\text{C}$  and  $I_L=120\text{ mA}$ . The LED lifetime could be decreased if operating  $I_L$  is larger than 120mA. The constant current driving method is suggested.

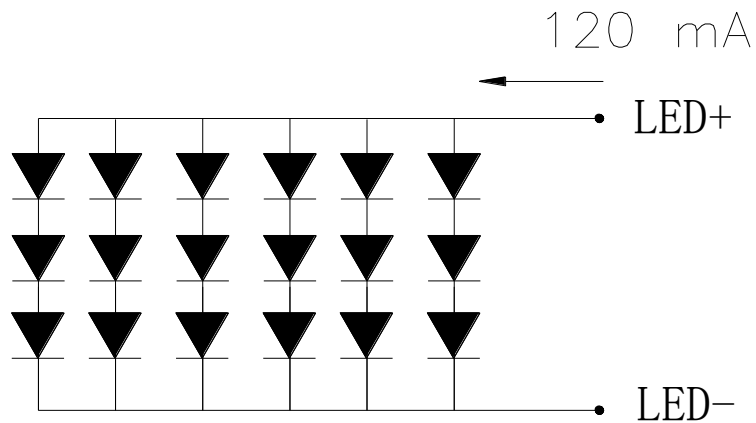

$I_F = 120\text{ mA}$ ,  $V_F = 9 \sim 10.2\text{ V}$

# backlight circuit

## 6. LCD TIMING CHARACTERISTICS

Item	Symbol	Min.	Typ.	Max.	Unit	Note
DCLK cycle time	Tclk	25	-	-	ns	
DCLK frequency	fclk	-	33	40	MHz	
DCLK pulse duty	Tcwh	40	50	60	%	
VSYNC setup time	Tvst	8	-	-	ns	
VSYNC hold time	Tvhd	8	-	-	ns	
HSYNC setup time	Thst	8	-	-	ns	
HSYNC hold time	Thhd	8	-	-	ns	
Data setup time	Tdasu	8	-	-	ns	
Data hold time	Tdahd	8	-	-	ns	
DE setup time	Tdesu	8	-	-	ns	
DE hold time	Tdehd	8	-	-	ns	
Horizontal display area	Thd	-	800	-	Tcph	
HSYNC period time	Th	-	928	-	Tcph	
HSYNC width	Thwh	1	48	-	Tcph	
HSYNC back porch	Thbp	-	40	-	Tcph	
HSYNC front porch	Thfp	-	40	-	Tcph	
Vertical display area	Tvd	-	480	-	th	
VSYNC period time	Tv	-	525	-	th	
VSYNC width	Tvwh	-	3	-	th	
VSYNC back porch	Tvbp	-	29	-	th	
VSYNC front porch	Tvfp	-	13	-	th	

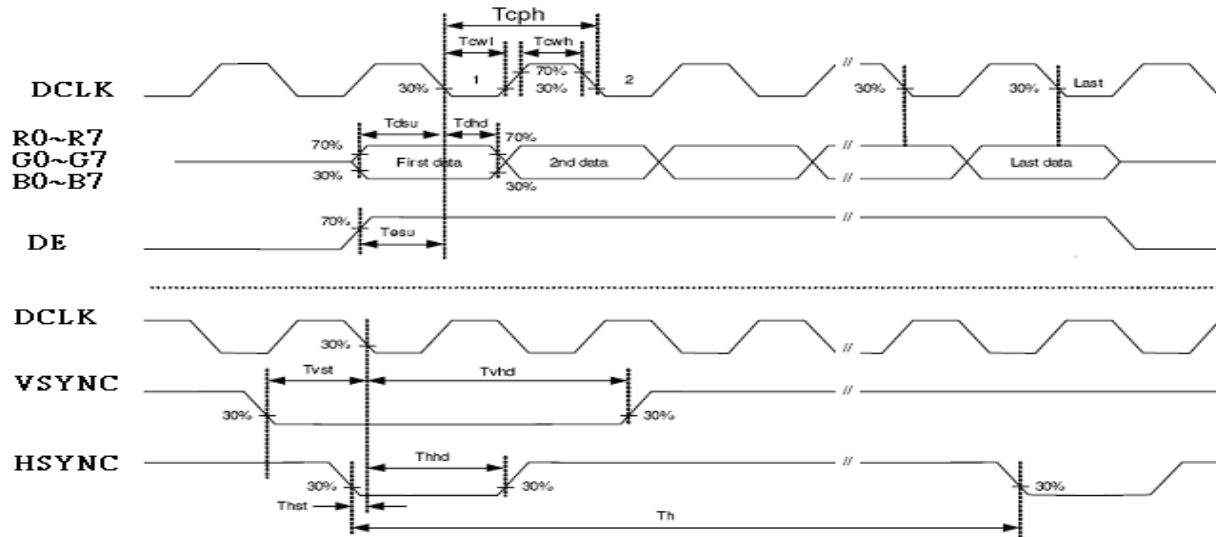
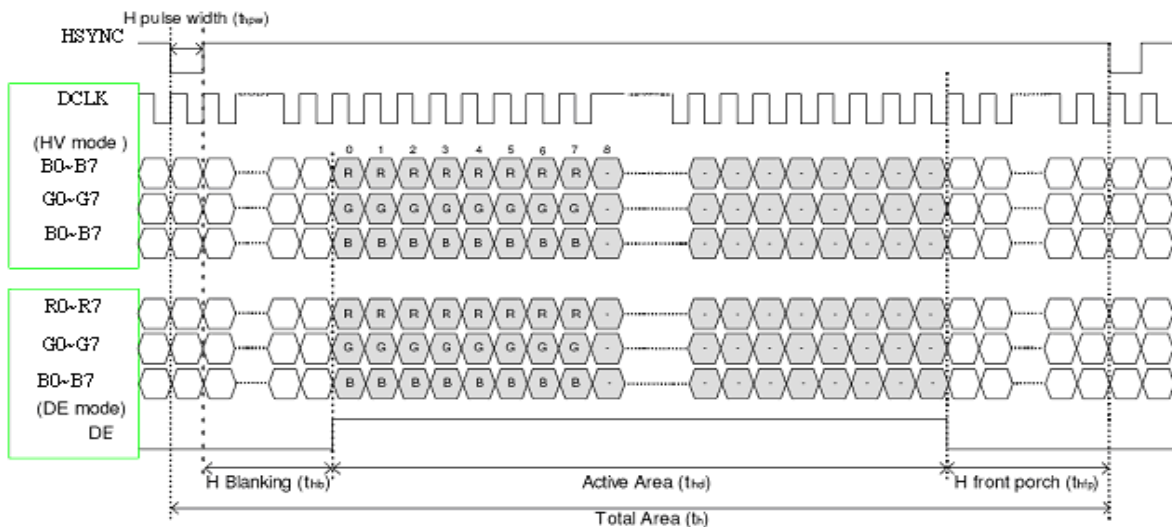
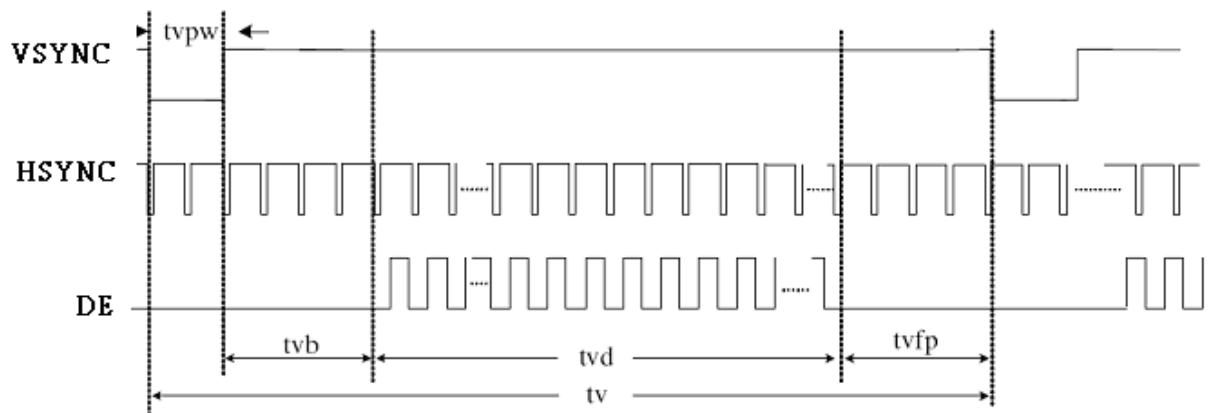
**Timing Diagram of Interface Signal**

**Sampling clock timing**

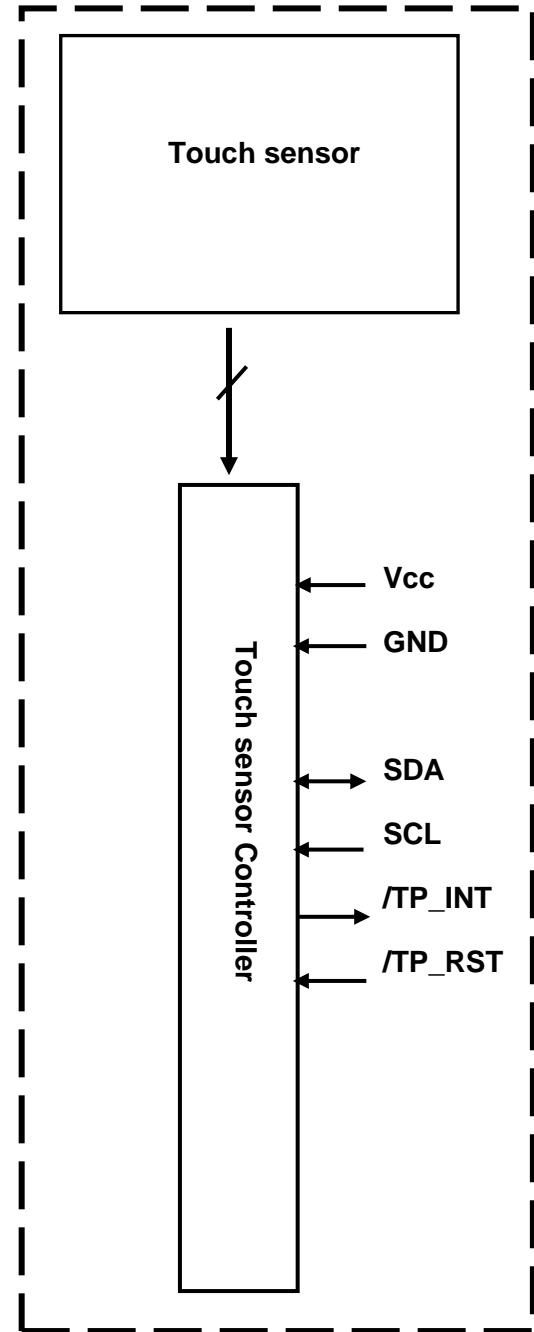
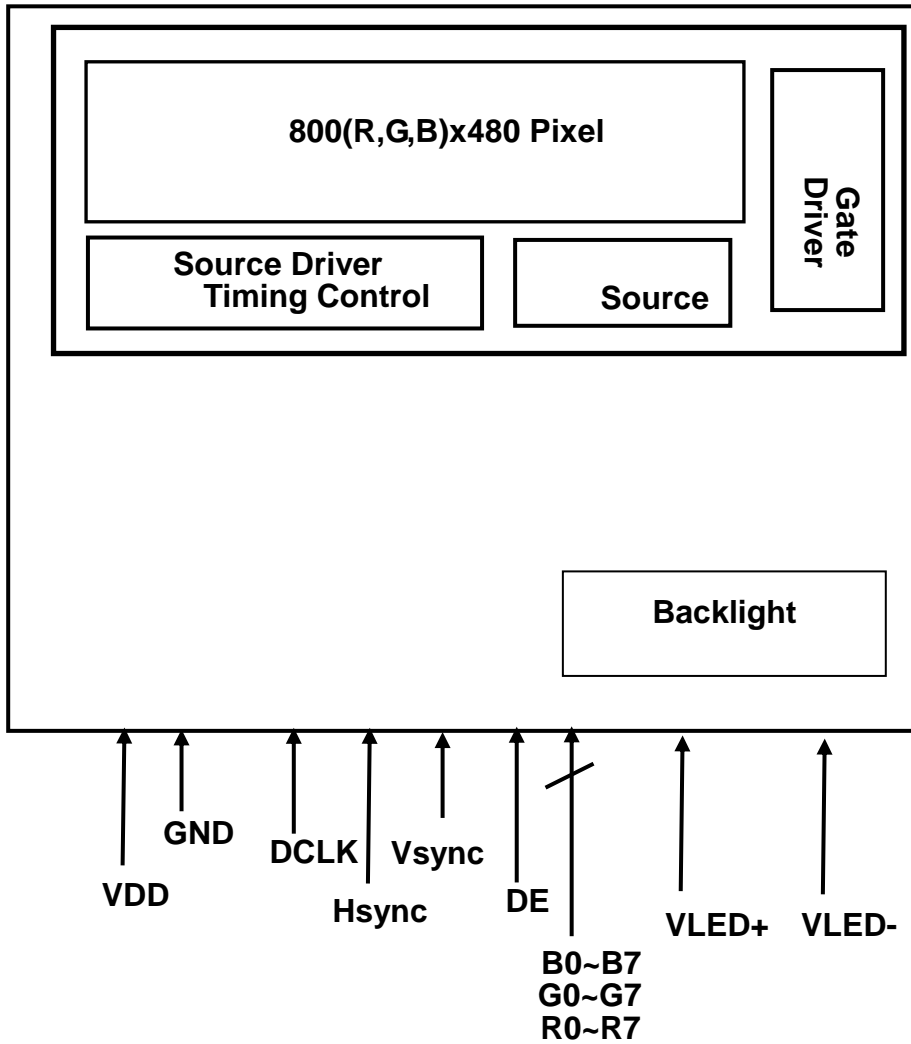
**Horizontal display timing range**

**Vertical timing**

## 7. BLOCK DIAGRAM



## 8. LCD PIN CONNECTIONS

### 8.1 Input Pins Function

Pin No.	Symbol	I/O	Function
1	VLED-	P	Power for LED backlight cathode
2	VLED+	P	Power for LED backlight anode
3	GND	P	Power ground
4	VDD	P	Power voltage
5	R0	I	Red data (LSB)
6	R1	I	Red data
7	R2	I	Red data
8	R3	I	Red data
9	R4	I	Red data
10	R5	I	Red data
11	R6	I	Red data
12	R7	I	Red data (MSB)
13	G0	I	Green data (LSB)
14	G1	I	Green data
15	G2	I	Green data
16	G3	I	Green data
17	G4	I	Green data
18	G5	I	Green data
19	G6	I	Green data
20	G7	I	Green data (MSB)
21	B0	I	Blue data (LSB)
22	B1	I	Blue data
23	B2	I	Blue data
24	B3	I	Blue data
25	B4	I	Blue data
26	B5	I	Blue data
27	B6	I	Blue data
28	B7	I	Blue data (MSB)
29	DGND	P	Digital ground
30	DCLK	I	Pixel clock
31	DISP	I	Display on/ off
32	Hsync	I	Horizontal sync signal
33	Vsync	I	Vertical sync signal
34	DE	I	Data enable
35	NC	-	No Connect
36	GND	P	Power ground
37	NC	-	No Connect
38	NC	-	No Connect
39	NC	-	No Connect
40	NC	-	No Connect



I/O:I: input, O: output, P: Power

## 8.2 Power Sequence

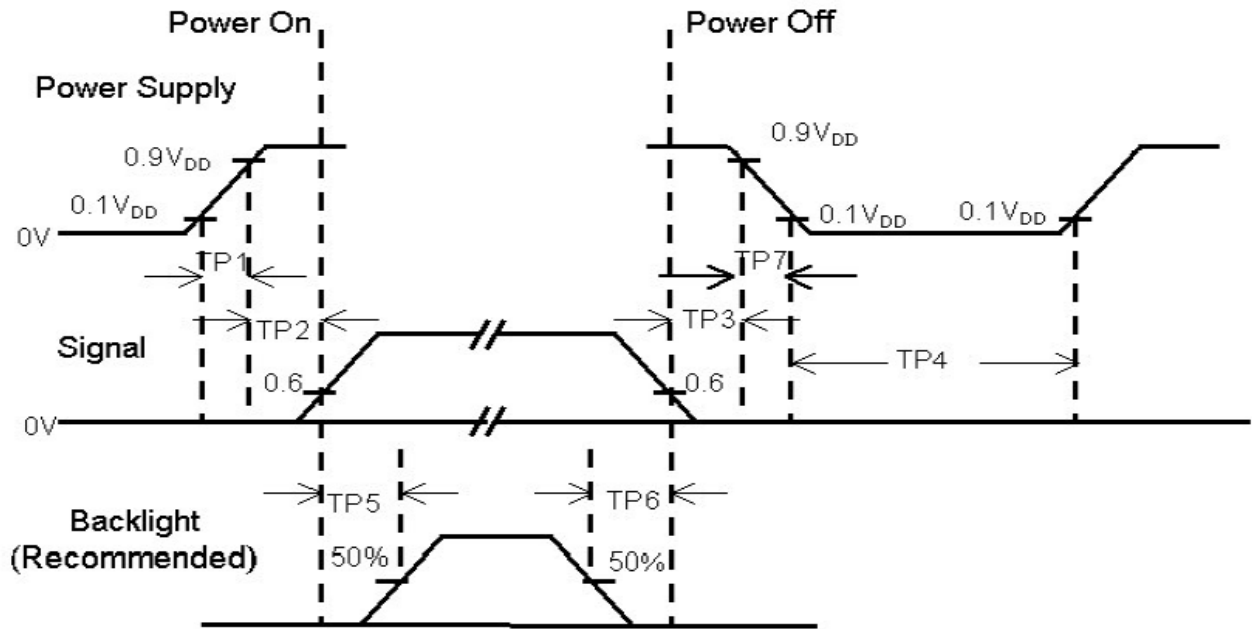

Item	Min.	Typ.	Max.	Unit	Remark
TP1	0.5	--	10	msec	
TP2	0	--	50	msec	
TP3	0	--	50	msec	
TP4	1000	--	--	msec	
TP5	200	--	--	msec	
TP6	200	--	--	msec	
TP7	0.5	--	10	msec	

Note:

- (1) The supply voltage of the external system for the module input should be the same as the definition of VDD.
- (2) Apply the lamp voltage within the LCD operation range. When the back-light turns on before the LCD operation or the LCD turns off before the back-light turns off, the display may momentarily become white.
- (3) In case of VDD = off level, please keep the level of input signal on the low or keep a high impedance.
- (4) TP4 should be measured after the module has been fully discharged between power off and on period.
- (5) Interface signal shall not be kept at high impedance when the power is on.

## 9. OPTICAL CHARACTERISTIC

### Specification:

Item		Symbol	Condition	Min.	Typ.	Max.	Unit	Remark
Response time	Rise	TON	Normal $\theta = \Phi = 0^\circ$	-	2	4	ms	Note3 , 4
	Fall	TOFF		-	6	12	ms	
Contrast ratio		CR		480	600	-		Note 2 , 4
Viewing angle	$\theta_L$	$\Phi = 180^\circ$ (9 o' clock)		65	75	-	Deg.	Note 1 , 4
	$\theta_R$	$\Phi = 0^\circ$ (3 o' clock)		65	75	-		
	$\theta_U$	$\Phi = 90^\circ$ (12 o' clock)		50	60	-		
	$\theta_D$	$\Phi = 270^\circ$ (6 o' clock)		60	70	-		
Brightness (Center)			Normal $\theta = \Phi = 0^\circ$	425	530	-	cd/m <sup>2</sup>	Note 4 , 6
Uniformity				70	-	-	%	Note 4 , 5 , 6
Color chromaticity (CIE1931)	White	X		0.26	0.31	0.36		Note 4 , 6
		y	0.28	0.33	0.38			

### Test Conditions:

Measuring surrounding: dark room  
 LED current IL: 120mA  
 Ambient temperature: 25±2°C  
 15 min. warm-up time.

Note (1): Definition of viewing angle range

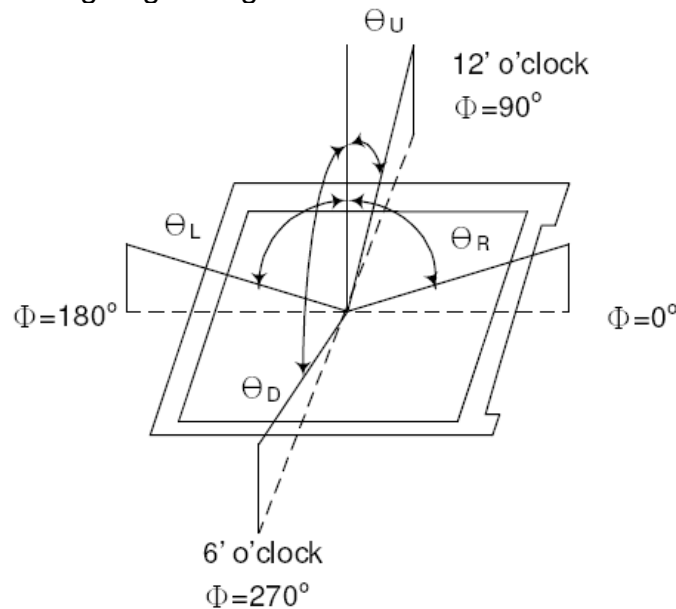

Note (2) Definition of Contrast Ratio (CR):  
Measured at the center point of panel

$$CR = \frac{\text{Luminance with all pixels white}}{\text{Luminance with all pixels black}}$$

Note (3) Definition of Response Time: Sum of T<sub>OFF</sub> and T<sub>ON</sub>

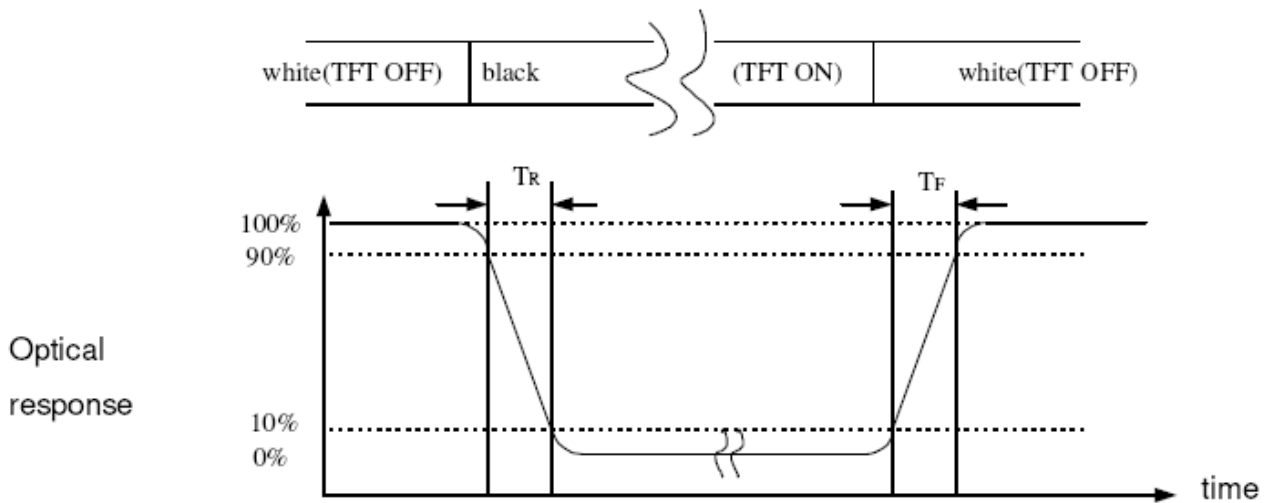

Note (4) The method of optical measurement:

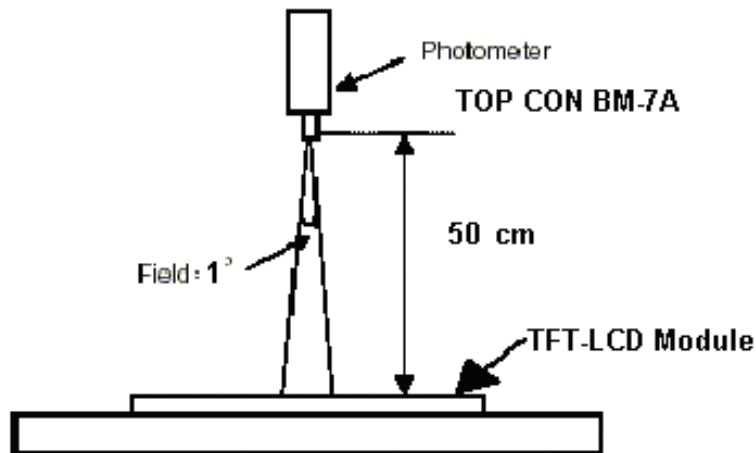

Note (5) Definition of brightness uniformity

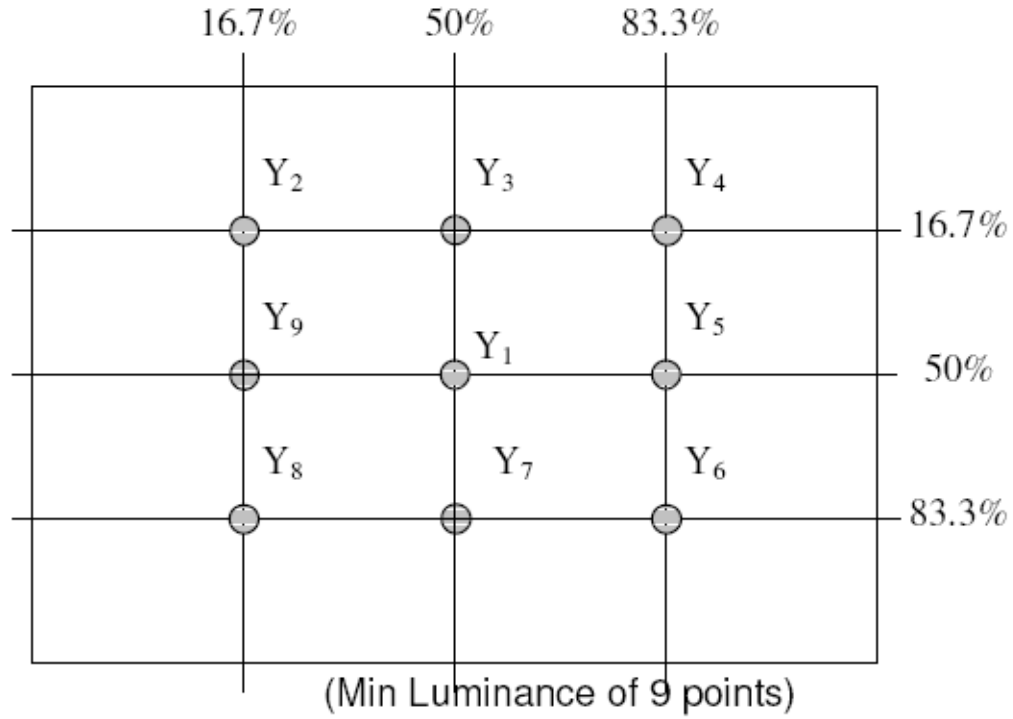

$$\text{Luminance uniformity} = \frac{\text{(Min Luminance of 9 points)}}{\text{(Max Luminance of 9 points)}} \times 100\%$$

Note (6) Measured at the center area of the panel when all terminals of LCD panel are electrically open.

## 10. CTP SPECIFICATIONS

### 10.1 Main feature

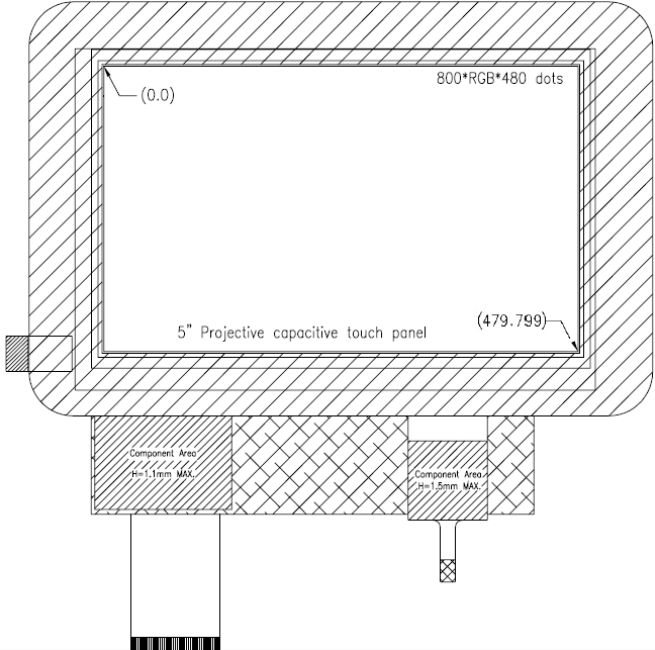
Item	Specification	Unit
Type	Transparent type projected capacitive touch panel	
Input mode	Human's finger	
Multi touch	2	Point
Interface	I <sup>2</sup> C	
Report rate	100	Hz
(X,Y)position		

### 10.2 Electrical Characteristic

Parameter	Symbol	MIN.	Typ.	MAX.	Unit	Remark
Power Supply voltage	V <sub>cc</sub>	3.0	3.3	3.6	V	
"H" level logical input voltage	V <sub>IH</sub>	1.9	--	V <sub>cc</sub>	V	
"L" level logical input voltage	V <sub>IL</sub>	0	--	1.3	V	
Normal mode		-	6	-	mA	
Power down			5		uA	

### 10.3 Pin Connections

NO.	Name	I/O	Description
1	V <sub>cc</sub>	-	Power; V <sub>cc</sub> =3.3V(typ.)
2	SCL	I	I <sup>2</sup> C Clock
3	SDA	I/O	I <sup>2</sup> C Data
4	/TP_INT	O	Active low when data output from touch panel
5	/TP_RST	I	CTP reset input pin, active low.
6	GND	-	Ground

## 10.4 CTP Interface and Data Format (Slave address is 0x55H)

Communication protocol: I<sup>2</sup>C

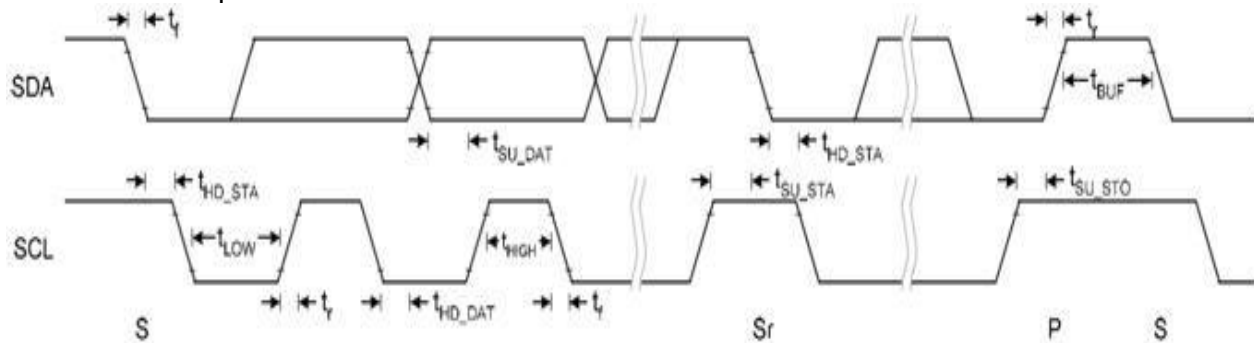

Symbol	Parameter	Rating			Unit
		Min.	Typ.	Max.	
f <sub>SCL</sub>	SCL clock frequency	0	-	400	kHz
t <sub>LOW</sub>	Low period of the SCL clock	1.3	-	-	us
t <sub>HIGH</sub>	High period of the SCL clock	0.6	-	-	us
t <sub>r</sub>	Signal falling time	-	-	300	ns
t <sub>r</sub>	Signal rising time	-	-	300	ns
t <sub>SU_STA</sub>	Set up time for a repeated START condition	0.6	-	-	us
t <sub>HD_STA</sub>	Hold time (repeated) START condition. After this period, the first clock pulse is generated.	0.6	-	-	us
t <sub>SU_DAT</sub>	Data set up time	100	-	-	ns
t <sub>HD_DAT</sub>	Data hold time	0	-	0.9	us
t <sub>SU_STO</sub>	Set up time for STOP condition	0.6	-	-	us
t <sub>BUF</sub>	Bus free time between a STOP and START condition	1.3	-	-	us
C <sub>b</sub>	Capacitive load for each bus line	-	-	400	pF

### 10.4.1 Register Read

For reading register value from I<sup>2</sup>C device, host has to tell I<sup>2</sup>C device the Start Register Address before reading corresponding register value.

I <sup>2</sup> C Start	I <sup>2</sup> C Header (W)	Start Reg. Addr. (a)	I <sup>2</sup> C Stop	I <sup>2</sup> C Start	I <sup>2</sup> C Header (R)	Value of Reg(a)	Value of Reg(a+1)	...	Value of Reg(a+n)	I <sup>2</sup> C Stop
------------------------	-----------------------------	----------------------	-----------------------	------------------------	-----------------------------	-----------------	-------------------	-----	-------------------	-----------------------

Figure 1 - Register Read Format.

The I<sup>2</sup>C host interface protocol supports Repeated Register Read. That is, once the Start Register Address has been set by host, consequent I<sup>2</sup>C Read(R) transactions will directly read register values starting from the Start Register Address without setting address first, as shown in Figure 2.

I <sup>2</sup> C Start	I <sup>2</sup> C Header (R)	Value of Reg(a)	Value of Reg(a+1)	...	Value of Reg(a+n)	I <sup>2</sup> C Stop	I <sup>2</sup> C Start	I <sup>2</sup> C Header (R)	Value of Reg(a)	Value of Reg(a+1)	...	Value of Reg(a+n)	I <sup>2</sup> C Stop
------------------------	-----------------------------	-----------------	-------------------	-----	-------------------	-----------------------	------------------------	-----------------------------	-----------------	-------------------	-----	-------------------	-----------------------

Figure 2 - Repeated Register Read.

### 10.4.2 Register Write

For writing register to I<sup>2</sup>C device, host has to tell I<sup>2</sup>C device the Start Register Address in each I<sup>2</sup>C Register Write transaction. Register values to the I<sup>2</sup>C device will be written to the address starting from the Start Register Address described in Register Write I<sup>2</sup>C transaction as shown in Figure 3.

I <sup>2</sup> C Start	I <sup>2</sup> C Header (W)	Start Reg. Addr. (a)	Value of Reg(a)	Value of Reg(a+1)	...	Value of Reg(a+n)	I <sup>2</sup> C Stop
------------------------	-----------------------------	----------------------	-----------------	-------------------	-----	-------------------	-----------------------

## 11. CTP REGISTERS

The provides a register set for host to configure device attributes and retrieve information about fingers, proximity, gestures or raw data through device host interface. Host interface registers are listed below.

Host Interface Registers (Report Page)									
Reg. Addr.	Name	Bit 7	Bit 6	Bit 5	Bit 4	Bit 3	Bit 2	Bit 1	Bit 0
0x00	Firmware Version	Version (RO)							
0x01	Status Reg.	Error Code (RO)				Device Status (RO)			
0x02	Device Control Reg.	Auto Tune (RW)	Flash Update Disable (RW)	Reserved		Gest. Enable (RW)	Proximity Enable (RW)	Power Down (RW)	Power Down (RW)
0x03	Timeout to Idle Reg.	Timeout to Idle (sec.) (RW)							
0x04	XY Resolution (High Byte)	X _ Res _ H (RW)				Y _ Res _ H (RW)			
0x05	X Resolution (Low Byte)	X _ Res _ L (RW)							
0x06	Y Resolution (Low Byte)	Y _ Res _ L (RW)							
:	:	:							
0x0C	Firmware Revision 3	FW_Rev_3							
0x0D	Firmware Revision 2	FW_Rev_2							
0x0E	Firmware Revision 1	FW_Rev_1							
0x0F	Firmware Revision 0	FW_Rev_0							
0x10	Fingers / Gesture	Gesture Code (RO)				Fingers (RO)			
:	:	:							
0x12	XY0 Coord. (High Byte)	Valid 0 (RO)	X0_H (RO)			Reserved	Y0_H (RO)		
0x13	X0 Coord. (Low Byte)	X0_L (RO)							
0x14	Y0 Coord. (Low Byte)	Y0_L (RO)							
0x15	XY1 Coord. (High Byte)	Valid 1 (RO)	X1_H (RO)			Reserved	Y1_H (RO)		
0x16	X1 Coord. (Low Byte)	X1_L (RO)							
0x17	Y1 Coord. (Low Byte)	Y1_L (RO)							
:	:	:							
0x40	Data [0] (High Byte)	Data _ H [0]							



0x41	Data [0] (Low Byte)	Data _ L [0]
0x42	Data [1] (High Byte)	Data _ H [1]
0x43	Data [1] (Low Byte)	Data _ L [1]
0x44	Data [2] (High Byte)	Data _ H [2]
0x45	Data [2] (Low Byte)	Data _ L [2]
⋮	⋮	⋮
0x7E	Raw Data[31] (High Byte)	Data _ H [31]
0x7F	Raw Data [31] (Low Byte)	Data _ L [31]
0x80 ⋮ 0xF E	⋮	Reserved
0xFF	Page Reg.	Page Number (RW)

**Figure 4 – Host Interface Registers**

### 11.1 Firmware Version Register

Reg. Addr.	Name	Bit 7	Bit 6	Bit 5	Bit 4	Bit 3	Bit 2	Bit 1	Bit 0
0x00	Firmware Version	Version (RO)							

Firmware Version Register provides version information about current firmware. Host application can support version control in firmware upgrade function by reading Firmware Version Register and comparing with the version of new firmware binary.

### 11.2 Status Register

Reg. Addr.	Name	Bit 7	Bit 6	Bit 5	Bit 4	Bit 3	Bit 2	Bit 1	Bit 0
0x01	Status Reg.	Error Code (RO)				Device Status (RO)			

Status Register shows current status of the device to host, including Device Status and Error Code. Init status represents that the device is in Init state and not ready for host access. Host has to wait for the device to change into Normal state before accessing registers other than Status Register.

If Device Status shows Error, the Error Code field in the Status Register gives reason of the error.

Device Status	
0x0	Normal
0x1	Init
0x2	Error
0x3	Auto Tuning
0x4	Idle
0x5	Power Down
0x6	Reserved
...	
0xF	

Error Code	
0x0	No Error
0x1	Invalid Address
0x2	Invalid Value
0x3	Invalid Platform
0x4	Reserved
...	
0xF	

### 11.3 Device Control Register

Reg. Addr.	Name	Bit 7	Bit 6	Bit 5	Bit 4	Bit 3	Bit 2	Bit 1	Bit 0
0x02	Firmware Version	Auto Tune (RW)	Flash Update Disable (RW)	Reserved		Gest. Enable (RW)	Proximity Enable (RW)	Power Down (RW)	Reset (RW)

Device Control Register provides device control bits for host to reset the device, power down the device, enable/disable proximity detection, enable/disable gestures or data mode. Power Down state will be updated to Device Status field of Status Register, 0x01, after setting/clearing Power Down bit. Set Data Mode to 0x1 for Raw Data mode. Set Data Mode to 0x02 for Delta mode. Set Auto Tune to 0x1 will enable Auto Tune. Set Flash Update Disable to 0x00 will write the Auto Tune's result to flash.

### 11.4 Proximity Enable and Timeout to Idle Register

Reg. Addr.	Name	Bit 7	Bit 6	Bit 5	Bit 4	Bit 3	Bit 2	Bit 1	Bit 0
0x03	Timeout to Idle Reg.	Timeout to Idle (sec.) (RW)							

Timeout to Idle Register provides timeout control to enter Idle Mode for host. The touch controller will enter Idle Mode after the number of seconds specified in Timeout to Idle Register if there is no touch detected in this period. Set this field to 0xFF will disable Idle Mode. Set this field to 0 will entering Idle Mode immediately. Idle state will be updated to Device Status field of Status Register, 0x01, after entering Idle Mode automatically.

The default value of Timeout to Idle Register is set to 0x08 for 8 seconds to Idle Mode.

### 11.5 XY Resolution Registers

Reg. Addr.	Name	Bit 7	Bit 6	Bit 5	Bit 4	Bit 3	Bit 2	Bit 1	Bit 0
0x04	XY Resolution (High Byte)	X _ Res _ H (RW)				Y _ Res _ H (RW)			
0x05	X Resolution (Low Byte)	X _ Res _ L (RW)							
0x06	Y Resolution (Low Byte)	Y _ Res _ L (RW)							

XY Resolution Registers represents resolution of X and Y coordinates of the touch screen. Host can change XY Resolution at run time by updating new resolution to these registers.

### 11.6 Firmware Revision Registers

Reg. Addr.	Name	Bit 7	Bit 6	Bit 5	Bit 4	Bit 3	Bit 2	Bit 1	Bit 0
0x0C	Firmware Revision 3	FW_Rev_3							
0x0D	Firmware Revision 2	FW_Rev_2							
0x0E	Firmware Revision 1	FW_Rev_1							
0x0F	Firmware Revision 0	FW_Rev_0							

Firmware Revision Registers provide revision information about current firmware.

### 11.7 Fingers and Gesture Register

Reg. Addr.	Name	Bit 7	Bit 6	Bit 5	Bit 4	Bit 3	Bit 2	Bit 1	Bit 0
0x10	Fingers / Gesture	Gesture Code (RO)				Fingers (RO)			

Fingers field represents number of fingers detected by touch controller. The coordinates of each finger detected are represents in X Coordinate and Y Coordinate fields. Gesture Register tells host which gesture is detected by the controller. Gesture Codes for each gesture are listed below.

Device Status		
0x0	No Detected	
0x1	Single Touch Tap	
0x2	Single Touch Double Tap	
0x3	Single Touch Slide Up	
0x4	Single Touch Slide Down	
0x5	Single Touch Slide Left	
0x6	Single Touch Slide Right	
0x7	Two Finger Slide Up	
0x8	Two Finger Slide Down	
0x9	Two Finger Slide Left	
0xA	Two Finger Slide Right	
0x0B	Pinch In (Zoom In)	
0x0C	Pinch Out (Zoom Out)	
0x0D	Rotate CW (CCW, for Top Down Mapping)	
0x0E	Rotate CCW (CW, for Top Down Mapping)	
0x0F	Object Approaching	
0x10	Object Leaving	
0x11	Reserved	
...		
0x1F		

### 11.8 XY Coordinate Registers

Reg. Addr.	Name	Bit 7	Bit 6	Bit 5	Bit 4	Bit 3	Bit 2	Bit 1	Bit 0
0x12	XY0 Coord. (High Byte)	Valid 0 (RO)	X0_H (RO)			Reserved	Y0_H (RO)		
0x13	X0 Coord. (Low Byte)	X0_L (RO)							
0x14	Y0 Coord. (Low Byte)	Y0_L (RO)							

XY Coordinate Registers represent the XY coordinates for each touch point ID. Valid bit field tells that this point ID is valid and the XY information represents a real touch point on touch sensor.

Z Coordinate Register indicates the touch strength of corresponding touch point ID.

### 11.9 Data Registers

Reg. Addr.	Name	Bit 7	Bit 6	Bit 5	Bit 4	Bit 3	Bit 2	Bit 1	Bit 0
0x40	Data [0] (High Byte)	Data _ H [0]							
0x41	Data [0] (Low Byte)	Data _ L [0]							
0x42	Data [1] (High Byte)	Data _ H [1]							
0x43	Data [1] (Low Byte)	Data _ L [1]							
0x44	Data [2] (High Byte)	Data _ H [2]							
0x45	Data [2] (Low Byte)	Data _ L [2]							
⋮	⋮	⋮							
0x7E	Raw Data[31] (High Byte)	Data _ H [31]							
0x7F	Raw Data [31] (Low Byte)	Data _ L [31]							

Data Registers provide raw or delta data detected by touch sensor controller. If Data Mode of Device Control Register (0x02) is set to Raw Mode, Data Registers represent raw data. If Data Mode is set to Delta Mode, Data Registers represent delta data. Data Registers will be updated for each scan frame when in raw or delta mode. Otherwise, Raw Data Registers will not be updated.

### 11.10 Page Register

Reg. Addr.	Name	Bit 7	Bit 6	Bit 5	Bit 4	Bit 3	Bit 2	Bit 1	Bit 0
0xFF	Page Reg.	Page Number (RW)							

Page Register provides changing page of Host Interface Register.  
Default page is Report Page.

Page Number	Description
0x00	Report Page
0x01	AutoTune Page

## 12. APPEARANCE SPECIFICATION

### 12.1 Inspection condition

#### 12.1.1 Inspection conditions

12.1.1.1 Inspection Distance :  $30 \pm 5$  cm

12.1.1.2 View Angle :

(1) Inspection that light pervious to the product:  $90 \pm 15^\circ$

(2) Inspection that light reflects on the product:  $90 \pm 15^\circ$

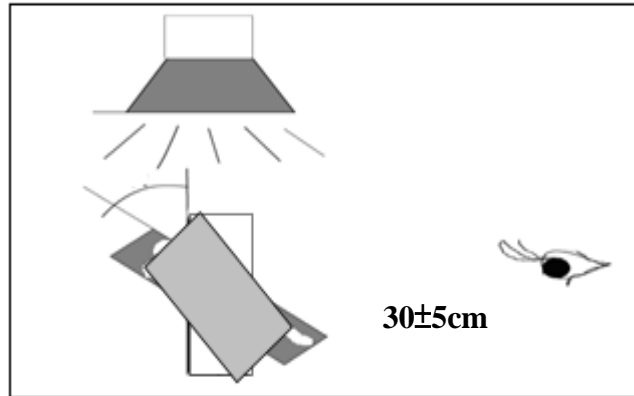
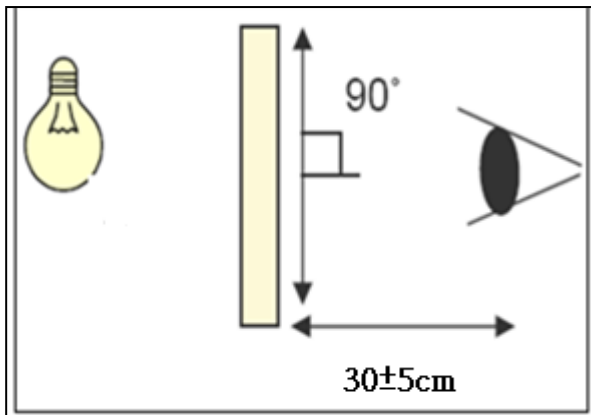



#### 12.1.2 Environment conditions :

Ambient Temperature :	$25 \pm 5^\circ\text{C}$
Ambient Humidity :	30~75%RH
Ambient Illumination	600~800 lux

### 12.2 Inspection Parameters

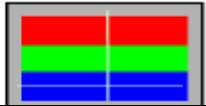
Appearance inspection standard (D: diameter, L: length; W: width, Z: height, T: glass thickness, n: number)

Inspection item	Inspection standard	Description
No image	Prohibited	
Image abnormal	Prohibited	
Bright line	Prohibited	
Thin line	It is acceptable that the defect can not be seen with 10% ND filter.	
Mura	It is acceptable that the defect can not be seen with 2% ND filter.	

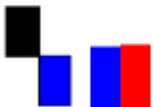
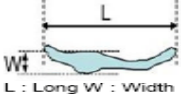
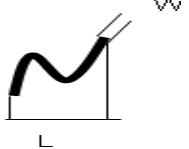
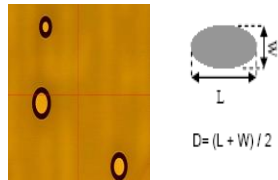
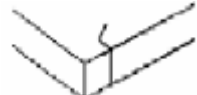
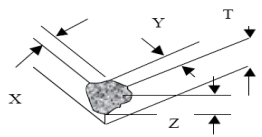
Dot	Item	Acceptable Visible area	Total	<p>One Dot </p> <p>Two adjacent dot </p>
	Bright dot	2		
Dark dot	4	1		
Bright adjacent dots	1		2	
Dark adjacent dots	2	1		
Adjacent dots with a bright dot and a dark dot	1	1		
Foreign material in dot shape	SPEC (unit: mm)		Acceptable	
	$D \leq 0.3$		Ignored	
	$0.3 < D \leq 0.5$ , distance >5		$n \leq 5$	
	$D > 0.5$		0	
Inspection item	Inspection standard		Description	
Foreign material in line shape	SPEC (unit: mm)		Acceptable	 L : Long W : Width
	$W \leq 0.05$ and $L \leq 7$		Ignored	
	$0.05 < W \leq 0.1$ , $L \leq 7$ , distance >5		$n \leq 5$	
	$W > 0.1$ or $L > 7$		0	
Contamination	It is acceptable if the dirt can be wiped.			
Scratch	SPEC (unit: mm)		Acceptable	
	$W \leq 0.05$ and $L \leq 7$		Ignored	
	$0.05 < W \leq 0.08$ , $L \leq 7$ , distance >5		$n \leq 5$	
	$0.08 < W \leq 0.1$ , $L \leq 7$ , distance >5		$n \leq 3$	
	$W > 0.1$ or $L > 7$		0	
Bubble	SPEC (unit: mm)		Acceptable	 $D = (L + W) / 2$
	$D \leq 0.2$		Ignored	
	Non visible area		Ignored	
	$0.2 < D \leq 0.3$ , distance >5		$n \leq 5$	
	$D > 0.3$		0	
Cover & Sensor Crack	Prohibited			
Cover angle missing	SPEC (unit: mm)		Acceptable	
	Side/Bottom		Ignored	
	It is prohibited if the defect appears on the front.		0	

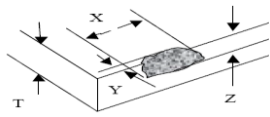
Cover edge break	SPEC (unit: mm)	Acceptable	
	$X \leq 2.0, Y \leq 2.0, Z \leq 1/2T$	Ignored	
	$X > 2.0, Y > 2.0, Z > 1/2T$	0	
Ink	SPEC (unit: mm)	Acceptable	
	word unclear, inverted, mistake, break line	0	
Bubble under protection film	SPEC (unit: mm)	Acceptable	
	NA		
Function	Prohibited		

### 12.3 Sampling Condition

Unless otherwise agree in written, the sampling inspection shall be applied to the incoming inspection of customer.

Lot size: Quantity of shipment lot per model.

Sampling type: normal inspection, single sampling

Sampling table: MIL-STD-105E

Inspection level: Level II

Class of defects	Definition		
	Major	AQL 0.65%	It is a defect that is likely to result in failure or to reduce materially the usability of the product for the intended function.
Minor	AQL 1.5%	It is a defect that will not result in functioning problem with deviation classified.	



### 13. QUALITY ASSURANCE

No.	Item	Test Conditions	Remark
1	High Temperature Storage	Ta = 80 °C 240 hrs	IEC68-2-2
2	Low Temperature Storage	Ta = -30°C 240hrs	IEC68-2-1
3	High Temperature Operation	Ta = 70°C 240hrs	IEC68-2-2
4	Low Temperature Operation	Ta = -20°C 240hrs	IEC68-2-1
5	Operate at High Temperature and Humidity	60°C , 90%RH 240 hrs	IEC68-2-3
6	Thermal Cycling Test (non operation)	-30°C (30 min) → + 80°C (30 min), 200 cycles	IEC68-2-14
7	Vibration Test(with carton)	Frequency:10~55HZ Amplitude:1.5mm Sweep time:11min Test period:6Cycles for each direction of X,Y,Z	IEC68-2-6
8	Drop Test(with carton)	Height:60 cm 1 corner, 3 edges, 6 surfaces	JIS Z0202
9	Electro Static Discharge	Location: LCM/TP surface Condition:150pf 330Ω Contact +/- 4kV Air +/-8kV Criteria: Class C	IEC-6100-4-2

## 14. LCM PRODUCT LABEL DEFINE

Product Label style:

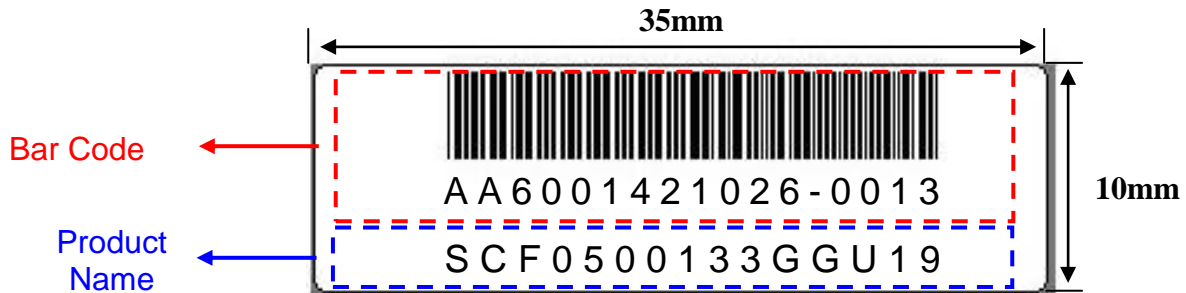

BarCode Define:

**A A 6 0014 2 10 26-0013**

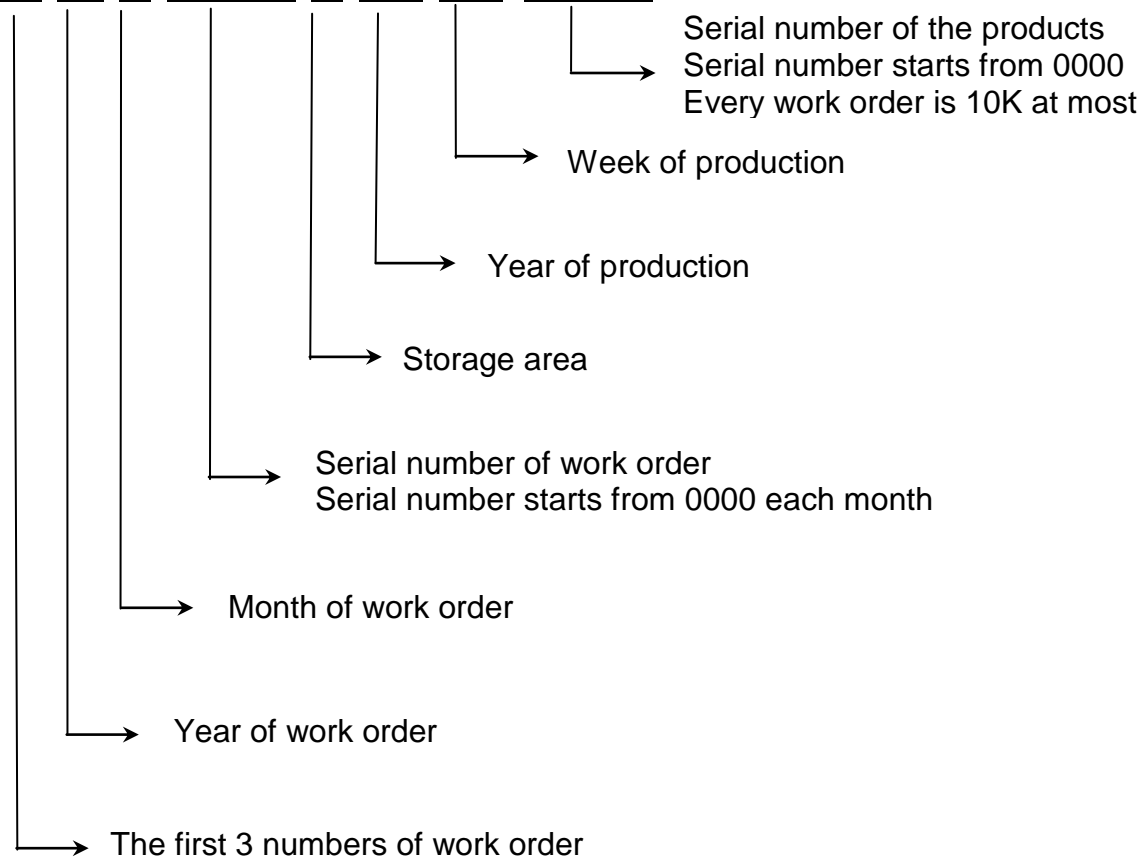

**Product Name Define:**

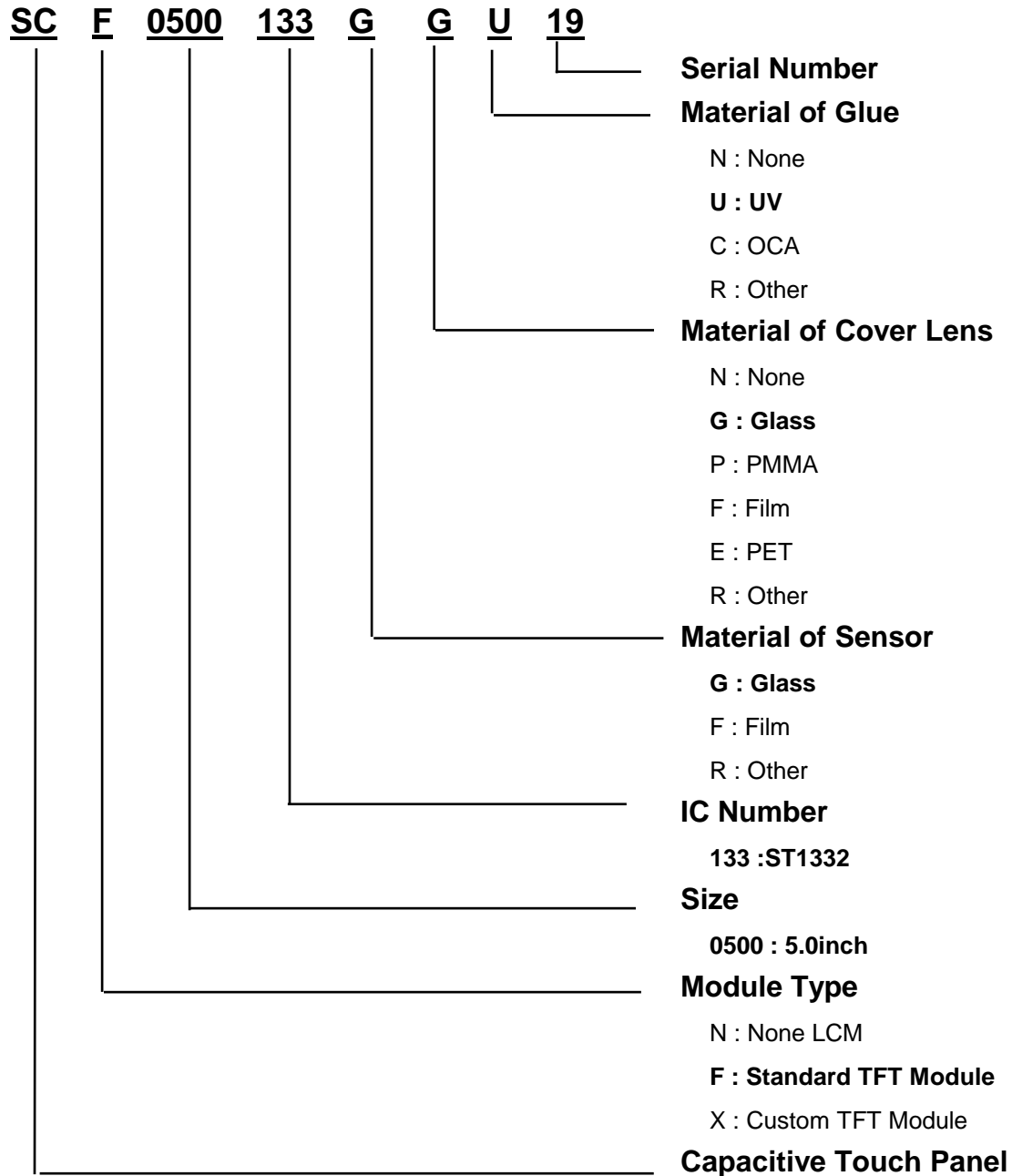

## 15. PRECAUTION FOR USING LCM

### 1. ASSEMBLY PRECAUTIONS

- (1) You must mount a module using holes arranged in four corners or four sides.
- (2) You should consider the mounting structure so that uneven force (ex. Twisted stress) is not applied to the module. And the case on which a module is mounted should have sufficient strength so that external force is not transmitted directly to the module.
- (3) Do not touch, push or rub the exposed polarizers with glass, tweezers or anything harder than HB pencil lead. And please do not rub with dust clothes with chemical treatment.
- (4) Wipe off saliva or water drops as soon as possible. Their long time contact with polarizer causes deformations and color fading.
- (5) Do not open the case because inside circuits do not have sufficient strength.
- (6) Please do not take a LCD module to pieces and reconstruct it. Resolving and reconstructing modules may cause them not to work well.
- (7) Please do not touch metal frames with bare hands and soiled gloves. A color change of the metal frames can happen during a long preservation of soiled LCD modules.
- (8) Please pay attention to handling lead wire of backlight so that it is not tugged in connecting with inverter.

### 2. OPERATING PRECAUTIONS

- (1) Please be sure to turn off the power supply before connecting and disconnecting signal input cable.
- (2) Please do not change variable resistance settings in LCD module. They are adjusted to the most suitable value. If they are changed, it might happen LCD does not satisfy the characteristics specification
- (3) Be careful for condensation at sudden temperature change. Condensation makes damage to polarizer or electrical contacted parts. And after fading condensation, smear or spot will occur.
- (4) When fixed patterns are displayed for a long time, remnant image is likely to occur.
- (5) Module has high frequency circuits. Sufficient suppression to the electromagnetic interference shall be done by system manufacturers. Grounding and shielding methods may be important to minimize the interference.
- (6) Please consider that LCD backlight takes longer time to become stable of radiation characteristics in low temperature than in room temperature.

### 3. ELECTROSTATIC DISCHARGE CONTROL

- (1) The operator should be grounded whenever he/she comes into contact with the module. Never touch any of the conductive parts such the copper leads on the PCB and the interface terminals with any

parts of the human body.

- (1) The modules should be kept in antistatic bags or other containers resistant to static for storage.
- (2) Only properly grounded soldering irons should be used.
- (3) If an electric screwdriver is used, it should be well grounded and shielded from commutator sparks.
- (4) The normal static prevention measures should be observed for work clothes and working benches; for the latter conductive (rubber) mat is recommended
- (5) Since dry air is inductive to statics, a relative humidity of 50-60% is recommended.

### 4. STORAGE PRECAUTIONS

- (1) When you store LCDs for a long time, it is recommended to keep the temperature between 0°C-40°C without the exposure of sunlight and to keep the humidity less than 90%RH.
- (2) Please do not leave the LCDs in the environment of high humidity and high temperature such as 60°C 90%RH
- (3) Please do not leave the LCDs in the environment of low temperature; below -20°C.

### 5. OTHERS

- (1) A strong incident light into LCD panel might cause display characteristics' changing inferior because of polarizer film, color filter, and other materials becoming inferior. Please do not expose LCD module direct sunlight and strong UV rays
- (2) Please pay attention to a panel side of LCD module not to contact with other materials in preserving it alone.
- (3) For the packaging box, please pay attention to the followings:
- (4) Please do not pile them up more than 5 boxes. (They are not designed so.) And please do not turn over.
- (5) Please handle packaging box with care not to give them sudden shock and vibrations. And also please do not throw them up.
- (6) Packing box and inner case for LCDs are made of cardboard. So please pay attention not to get them wet. (Such like keeping them in high humidity or wet place can occur getting them wet.)

### 6. LIMITED WARRANTY

Unless otherwise agreed between DATA IMAGE and customer, DATA IMAGE will replace or repair any of its LCD and LCM which is found to be defective electrically and visually when inspected in accordance with DATA IMAGE acceptance standards, for a period on one year from date of shipment. Confirmation of such date shall be based on freight documents. The warranty liability of DATA IMAGE is limited to repair and/or replacement on the terms set forth above. DATA IMAGE will not be responsible for any subsequent or consequential events.

# 16. OUTLINE DRAWING

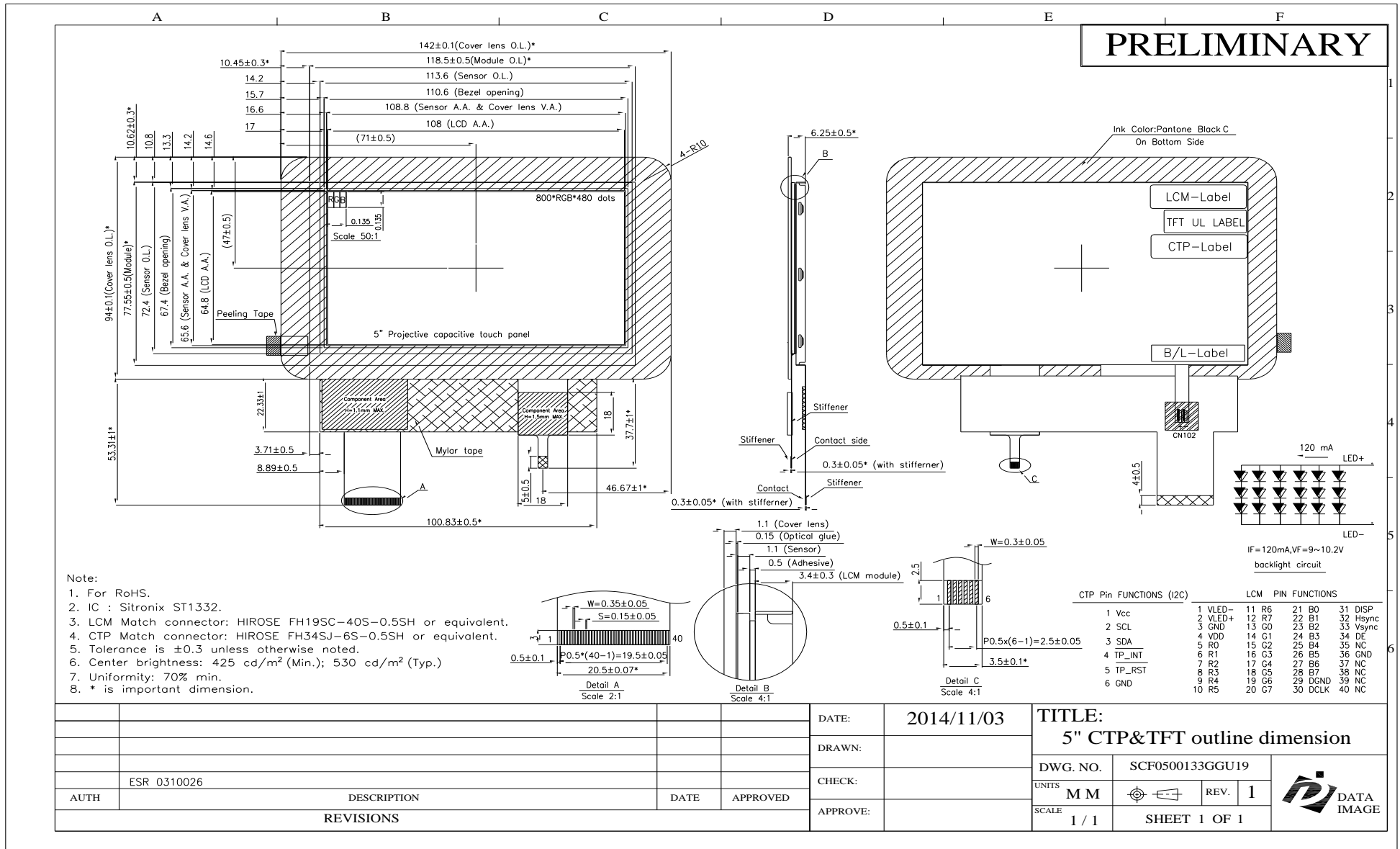

## 17. PACKAGE INFORMATION

TBD