

TECHNICAL SPECIFICATION

MODEL NO. : PD035VX8

The content of this information is subject to be changed without notice.
Please contact E Ink or its agent for further information.





Customer's Confirmation

Customer _____

Date _____

By _____

E Ink's Confirmation

Dep	PM	FAE	Panel Design	Electronic Design	Mechanical Design	Product Verification	Prepared by
SIGN							

Revision History

Rev.	Issued Date	Revised Contents
0.1	Dec.13 ,2010	New
0.2	Feb.09 ,2011	1.Modify 4. Mechanical Drawing of TFT-LCD module Add PLR tolerance 1.Modify 5.Input / Output Terminals 2.Modify 10. Block Diagram 3.Modify 11.Interface Timing 4.Modify 14. Optical Characteristics

TECHNICAL SPECIFICATION CONTENTS

<i>NO.</i>	<i>ITEM</i>	<i>PAGE</i>
-	Cover	1
-	Revision History	2
-	Contents	3
1	Application	4
2	Features	4
3	Mechanical Specifications	4
4	Mechanical Drawing of TFT-LCD module	5
5	Input / Output Terminals	6
6	Absolute Maximum Ratings	9
7	Electrical Characteristics	9
8	Pixel Arrangement	9
9	Display Color and Gray Scale Reference	10
10	Block Diagram	11
11	Interface Timing	12
12	Power On Sequence	19
13	Optical Characteristics	19
14	Handling Cautions	23
15	Reliability Test	24
16	Packing	25

1. Application

This data sheet applies to a color TFT LCD module, PD035VX8. The module applies to OA product, GPS, which require high quality flat panel display. If you must use in high reliability environment can't over reliability test condition.

2. Features

- . Amorphous silicon TFT LCD panel with LED back-light unit
- . Pixel in stripe configuration
- . Display Colors : 262,144 colors
- . Optimum Viewing Direction : 6 o'clock

3. Mechanical Specifications

Parameter	Specifications	Unit
Screen Size	3.5 (diagonal)	inch
Display Format	480×(R, G, B)×640	dot
Display Colors	262,144	
Active Area	53.28 (H)×71.04 (V)	mm
Pixel Pitch	0.111 (H)×0.111 (V)	mm
Pixel Configuration	Stripe	
Outline Dimension	64 (H)×85 (V)×3.1 (D) 64 (H)×85 (V)×4.2 (D) (Components side)	mm
Back-light	9-LEDs	
Weight	TBD	g
Surface treatment	Anti-Glare	
Display mode	Normally white	
Gray scale inversion direction	6 o'clock [ref to Note 13-1]	

5.Input / Output Terminals

Pin NO.	Symbol	Function	Remark
1	GND	Ground	
2		NC	
3		NC	
4		NC	
5		NC	
6	GND	Ground	
7	EXTC	Extended command set enable.	Note5-1
8	VCC	Power supply for analog circuit	Note5-2
9	NC	NC	
10	VCI	Power supply for digital circuit	Note5-2
11	NC	NC	
12	IOVCC	Power supply Interface pins	Note5-2
13	IM0	MPU Interface Select Pin	Note5-3
14	IM1	MPU Interface Select Pin	
15	IM2	MPU Interface Select Pin	
16	IM3	MPU Interface Select Pin	
17	RESX	Reset Input Pin	
18	NC	NC	
19	NC	NC	
20	NC	NC	
21	NC	NC	
22	NC	NC	
23	NC	NC	
24	DB17	Parallel data bus	
25	DB16	Parallel data bus	
26	DB15	Parallel data bus	
27	DB14	Parallel data bus	
28	DB13	Parallel data bus	
29	DB12	Parallel data bus	
30	DB11	Parallel data bus	
31	DB10	Parallel data bus	
32	DB9	Parallel data bus	
33	DB8	Parallel data bus	
34	DB7	Parallel data bus	
35	DB6	Parallel data bus	
36	DB5	Parallel data bus	
37	DB4	Parallel data bus	

38	DB3	Parallel data bus	
39	DB2	Parallel data bus	
40	DB1	Parallel data bus	
41	DB0	Parallel data bus	
42	RDX	8080 system (RDX): Serves as a read signal and read data at the rising edge.	
		- 8080 system (WRX): Serves as a write signal and writes data at the rising edge.	
43	WRX_DCX	- Serial interface (DCX): The signal for command or parameter select.	
		- 8080 system (DCX): The signal for command or parameter select.	
44	DCX_SCL	- Serial interface (SCL): Serial clock input.	
45	CSX	Chip select	
46	SDA	Serial data input / output.	
47	VSYNC	Frame synchronization signal	
48	HSYNC	Line synchronization signal	
49	ENABLE	- Data enable signal for RGB interface operation.	
50	DOTCLK	- Dot clock signal for RGB interface operation.	
51	NC	NC	
52	NC	NC	
53	NC	NC	
54	NC	NC	
55	NC	NC	
56	NC	NC	
57	NC	NC	
58	PWM_OUT	- Back light control pin. The PWM frequency output for LED driver control.	
		- Back light control pin. This pin is connected to external LED driver, It's a LED driver control pin which is used for turning ON/OFF of LED back light.	
59	BC_CTL		
60	LED-	Cathode of LED	
61	LED+	Anode of LED	

Note : 5-1

Extended command set enable :

Low: extended command set is discarded.

High: extended command set is accepted.

Note : 5-2

VCC : Connect to an external power supply of 3 V.

VCI : Connect to an external power supply of 3 V.

IOVCC : Connect to an external power supply of 3 V.

Note : 5-3

MPU Interface Select Pin

IM3	IM2	IM1	IM0	Interface	Data Pin in Use
0	0	1	0	8080 16-bit bus interface DB[15:0]	DB[15:0]
0	1	0	1	Serial interface	SDA

6. Absolute Maximum Ratings:

VSS=0V, Ta=25°C

Item	Symbol	Unit	Value	Note
Supply voltage	VCI	V	-0.3~+5.0	
Supply voltage (Logic)	IOVCC,VCC	V	-0.3~+4.6	
Supply voltage (Digital)	VCORE	V	-0.3~+2.4	
Driver supply voltage	VGH-VGL	V	-0.3~+33.0	
Logic input voltage range	VIN	V	-0.3~IOVCC+0.3	
Logic output voltage range	VOUT	V	-0.3~IOVCC+0.3	
Operating temperature	Topr	°C	-20~+70	
Storage temperature	Tstg	°C	-30~+80	

7. Electrical Characteristics
7-1) Operation Condition

TBD

7-2) Backlight driving

TBD

8. Pixel Arrangement

TBD

9. Display Color and Gray Scale Reference

Color		Input Color Data																	
		Red						Green						Blue					
		R5	R4	R3	R2	R1	R0	G5	G4	G3	G2	G1	G0	B5	B4	B3	B2	B1	B0
Basic Colors	Black	0	0	0	0	0	0	0	0	0	0	0	0	0	0	0	0	0	0
	Red (63)	1	1	1	1	1	1	0	0	0	0	0	0	0	0	0	0	0	0
	Green (63)	0	0	0	0	0	0	1	1	1	1	1	1	0	0	0	0	0	0
	Blue (63)	0	0	0	0	0	0	0	0	0	0	0	0	1	1	1	1	1	1
	Cyan	0	0	0	0	0	0	1	1	1	1	1	1	1	1	1	1	1	1
	Magenta	1	1	1	1	1	1	0	0	0	0	0	0	1	1	1	1	1	1
	Yellow	1	1	1	1	1	1	1	1	1	1	1	1	0	0	0	0	0	0
	White	1	1	1	1	1	1	1	1	1	1	1	1	1	1	1	1	1	1
Red	Red (00)	0	0	0	0	0	0	0	0	0	0	0	0	0	0	0	0	0	0
	Red (01)	0	0	0	0	0	1	0	0	0	0	0	0	0	0	0	0	0	0
	Red (02)	0	0	0	0	1	0	0	0	0	0	0	0	0	0	0	0	0	0
	Darker																		
	↓	↓	↓	↓	↓	↓	↓	↓	↓	↓	↓	↓	↓	↓	↓	↓	↓	↓	↓
	Brighter																		
	Red (61)	1	1	1	1	0	1	0	0	0	0	0	0	0	0	0	0	0	0
	Red (62)	1	1	1	1	1	0	0	0	0	0	0	0	0	0	0	0	0	0
Red (63)	1	1	1	1	1	1	0	0	0	0	0	0	0	0	0	0	0	0	
Green	Green (00)	0	0	0	0	0	0	0	0	0	0	0	0	0	0	0	0	0	0
	Green (01)	0	0	0	0	0	0	0	0	0	0	0	1	0	0	0	0	0	0
	Green (02)	0	0	0	0	0	0	0	0	0	0	1	0	0	0	0	0	0	0
	Darker																		
	↓	↓	↓	↓	↓	↓	↓	↓	↓	↓	↓	↓	↓	↓	↓	↓	↓	↓	↓
	Brighter																		
	Green (61)	0	0	0	0	0	0	1	1	1	1	0	1	0	0	0	0	0	0
	Green (62)	0	0	0	0	0	0	1	1	1	1	1	0	0	0	0	0	0	0
Green (63)	0	0	0	0	0	0	1	1	1	1	1	1	0	0	0	0	0	0	
Blue	Blue (00)	0	0	0	0	0	0	0	0	0	0	0	0	0	0	0	0	0	0
	Blue (01)	0	0	0	0	0	0	0	0	0	0	0	0	0	0	0	0	0	1
	Blue (02)	0	0	0	0	0	0	0	0	0	0	0	0	0	0	0	0	1	0
	Darker																		
	↓	↓	↓	↓	↓	↓	↓	↓	↓	↓	↓	↓	↓	↓	↓	↓	↓	↓	↓
	Brighter																		
	Blue (61)	0	0	0	0	0	0	0	0	0	0	0	0	1	1	1	1	0	1
	Blue (62)	0	0	0	0	0	0	0	0	0	0	0	0	1	1	1	1	1	0
Blue (63)	0	0	0	0	0	0	0	0	0	0	0	0	1	1	1	1	1	1	

10. Block Diagram

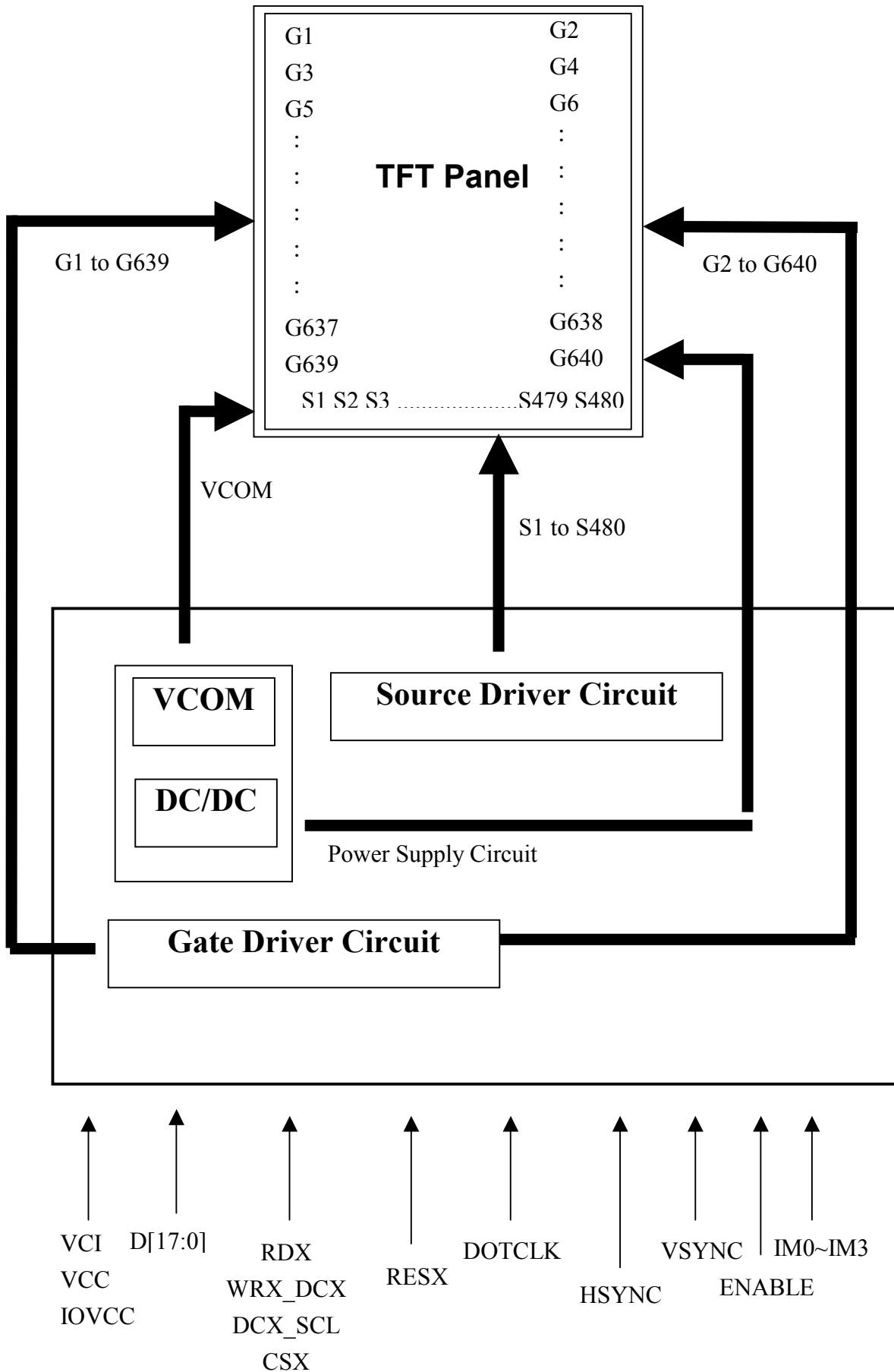

11.Interface Timing

11-1) Serial Interface Mode

11-1-1) Block Diagram

The serial bus interface can be used by setting external pin as IM [3:0] to “0101”.The figure in the following is the example of interface with microcomputer system interface.

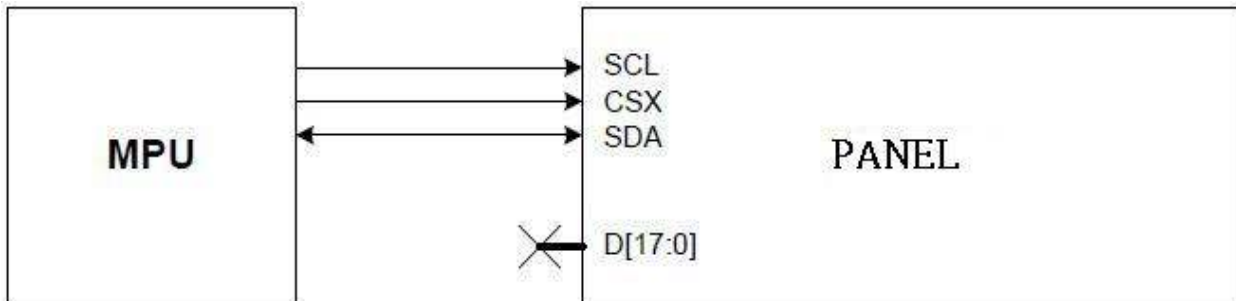

11-1-2) Data Format

The serial data packet contains a data/command select bit (D/CX) and a transmission byte. If D/CX is “low”, the transmission byte is interpreted as a command byte. If D/CX is “high”, the transmission byte is stored in the display data RAM (Memory write command), or command register as parameter.

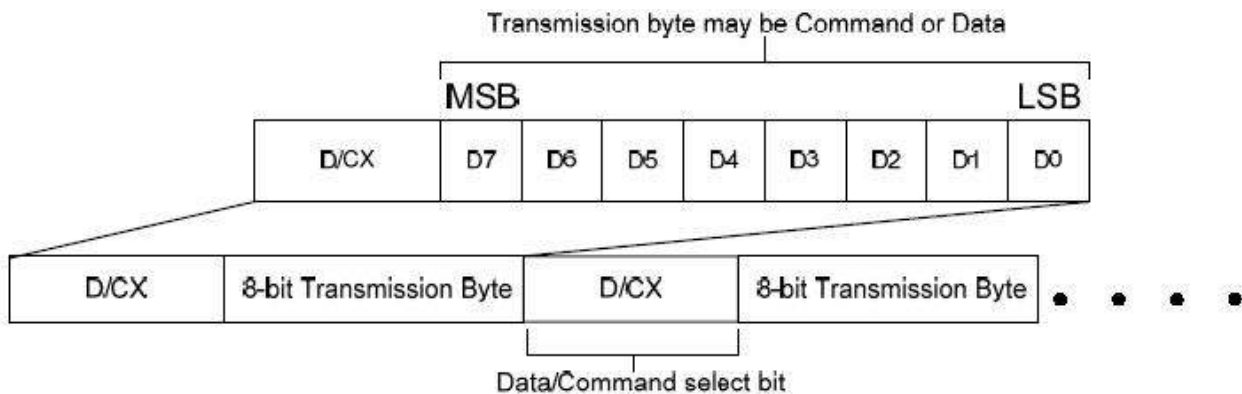

11-1-3) Serial Interface Protocol

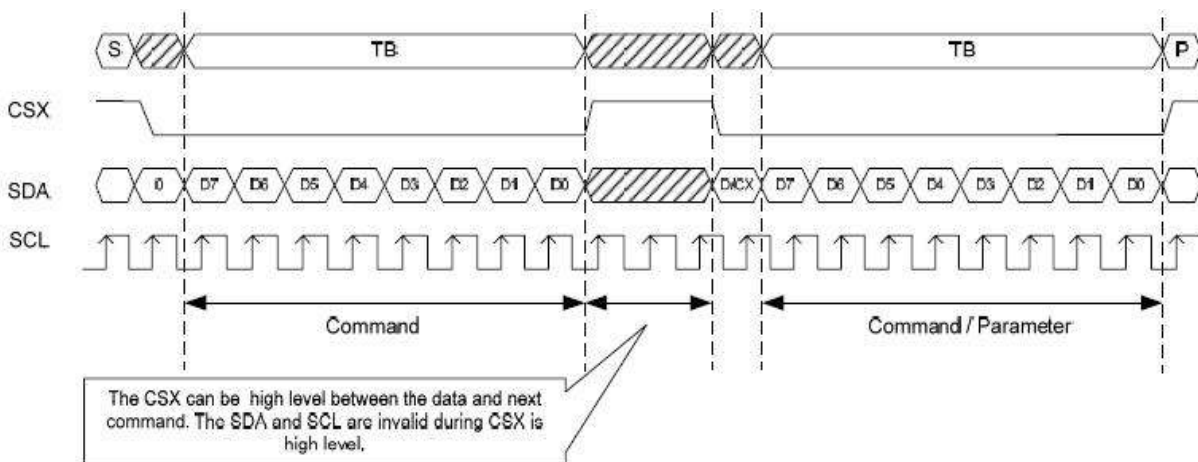

11-1-4) Timing Diagram

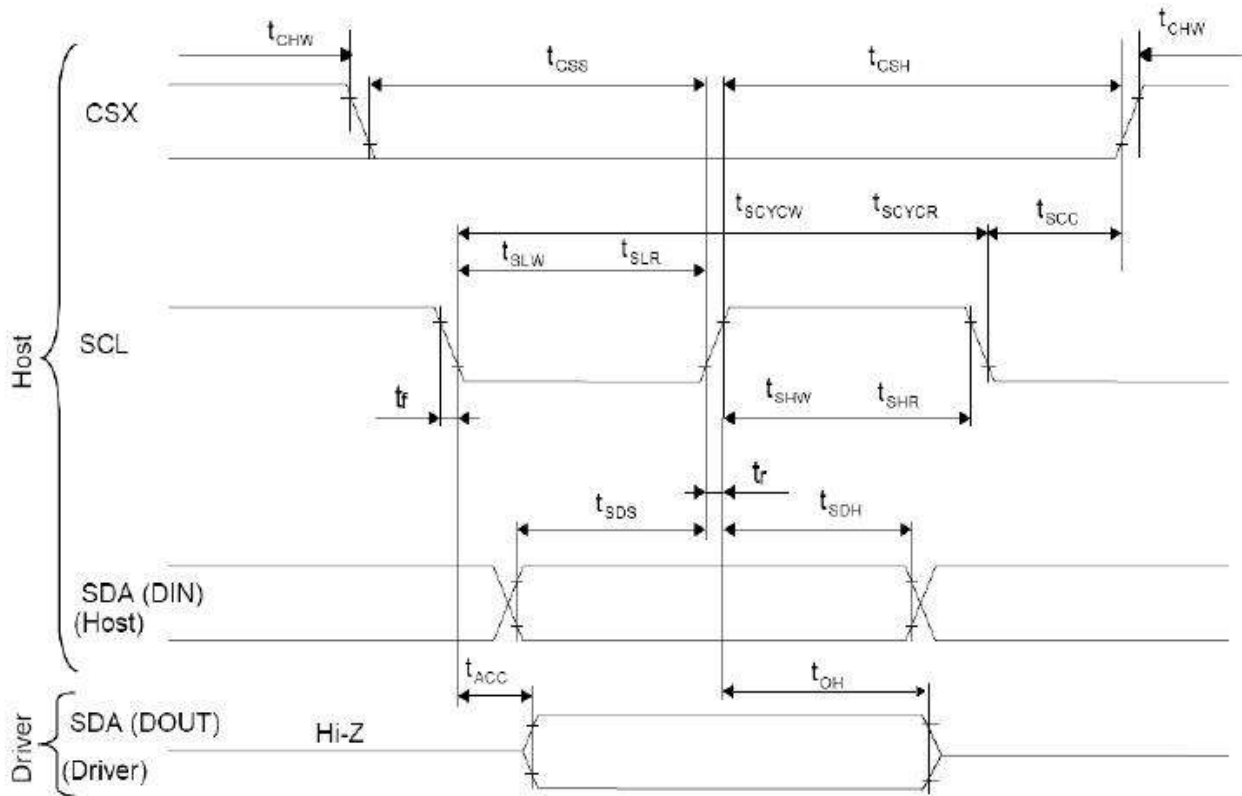

Signal	Symbol	Parameter	min	max	Unit	Description
SCL	tscycw	Serial Clock Cycle (Write)	40	-	ns	
	tshw	SCL "H" Pulse Width (Write)	15	-	ns	
	tslw	SCL "L" Pulse Width (Write)	15	-	ns	
	tscycr	Serial Clock Cycle (Read)	150	-	ns	
	tshr	SCL "H" Pulse Width (Read)	60	-	ns	
	tslr	SCL "L" Pulse Width (Read)	60	-	ns	
SDA / SDI (Input)	tsds	Data setup time (Write)	10	-	ns	
	tsdh	Data hold time (Write)	10	-	ns	
SDA / SDO (Output)	tacc	Access time (Read)	10	60	ns	
	toh	Output disable time (Read)	15	-	ns	
CSX	tsc	SCL-CSX	30	-	ns	
	tchw	CSX "H" Pulse Width	60	-	ns	
	tc	CSX-SCL Time	15	-	ns	
	tsh		15	-	ns	

11-2) 8080-Series Parallel Interface Mode

11-2-1) Block Diagram

The 8080-system 16-bit parallel bus interface can be used by setting external pin as IM [3:0] to "0010". The figure in the following is the example of interface with microcomputer system interface.

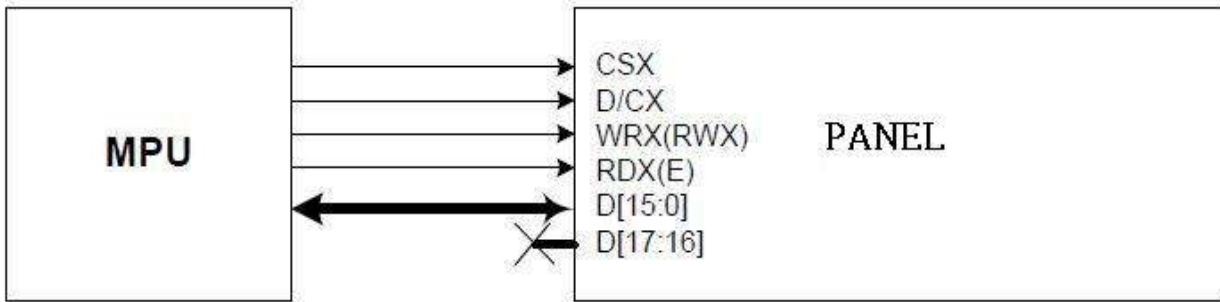

11-2-2) Timing Diagram

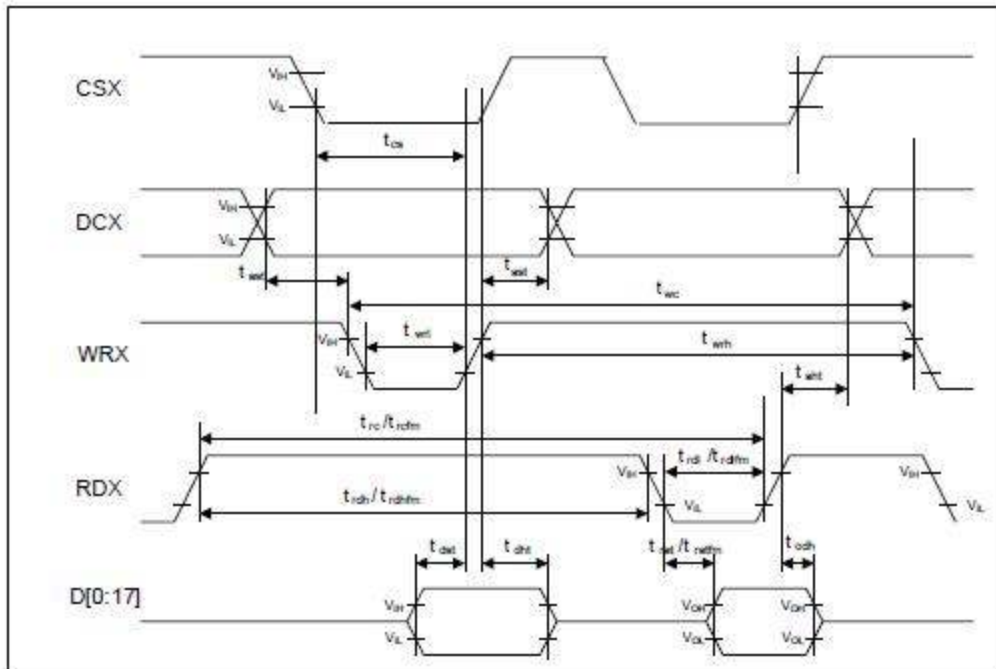

Signal	Symbol	Parameter	min	max	Unit	Description
DCX	tast	Address setup time	0	-	ns	-
	taht	Address hold time (Write/Read)	10	-	ns	-
WRX	twc	Write cycle	30	-	ns	-
	twrh	Write Control pulse H duration	15	-	ns	-
RDX (FM)	twrl	Write Control pulse L duration	15	-	ns	-
	trcfm	Read Cycle (FM)	450	-	ns	When read from Frame Memory
	trdhfm	Read Control H duration (FM)	90	-	ns	
trldfm	Read Control L duration (FM)	355	-	ns		
RDX (ID)	trc	Read cycle (ID)	160	-	ns	When read ID data
	trdh	Read Control pulse H duration	90	-	ns	
	trdl	Read Control pulse L duration	45	-	ns	
DB[17:0], DB[15:0], DB[8:0], DB[7:0]	tdst	Write data setup time	10	-	ns	For maximum CL=30pF For minimum CL=8pF
	tdht	Write data hold time	10	-	ns	
	trat	Read access time	-	40	ns	
	tratfm	Read access time	-	340	ns	
	trodh	Read output disable time	20	80	ns	

Note: (1) Ta = -30 to 70 °C, IOVCC=1.65V to 3.3V, VCC=2.5V to 3.3V, AGND=DGND=0V

11-3) RGB Interface Mode

11-3-1) Block Diagram

This mode is operated with VSYNC, HSYNC, ENABLE, DOTCLK, DB[17:0] lines. The mode can be used by setting external pin as IM [3:0] to "0101". The figure in the following is the example of interface with microcomputer system interface.

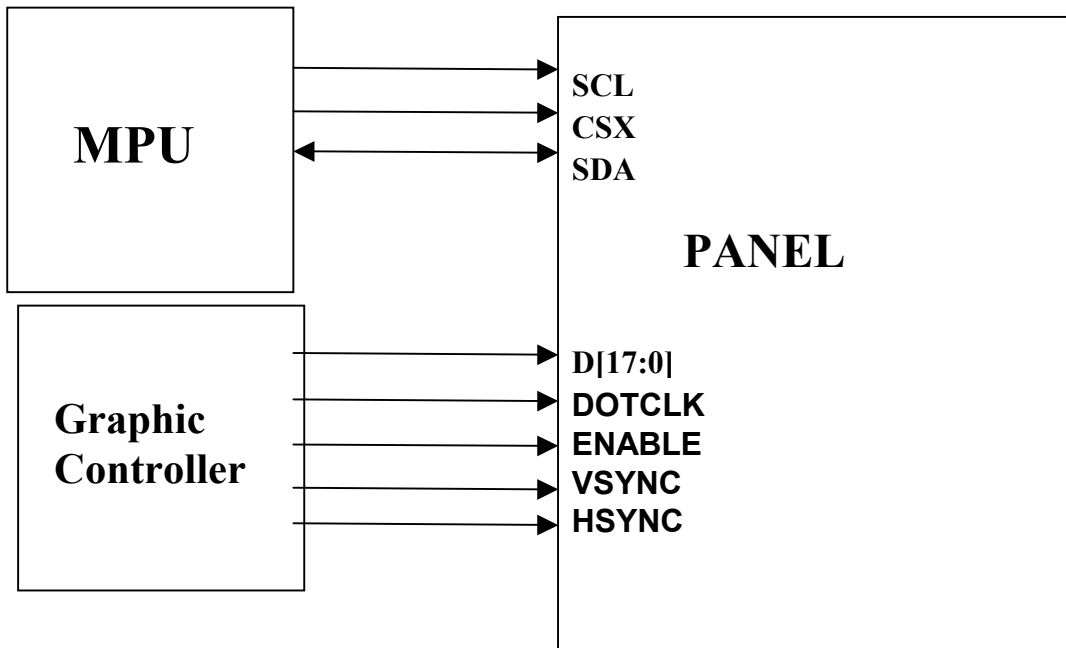

11-3-2) RGB Interface Selection

The panel supports several pixel format that can be selected by DPI [2:0] bits in “Pixel Format Set (3Ah)”command. The selection of a given interfaces are done by DPI [2:0] as show in the following table.

DPI[2:0]			RGB Interface Mode	Used Pins
1	0	1	16-bit RGB interface	VSYNC, HSYNC, ENABLE, DB[15:0]
1	1	0	18-bit RGB interface	VSYNC, HSYNC, ENABLE, DB[17:0]
Other			Setting prohibited	

The 18-bit RGB interface is selected by setting the DPI[2:0] bits to “110”. The display operation is synchronized with VSYNC, HSYNC and DOTCLK signals. The display data are transferred to the internal GRAM in synchronization with the display operation via 18-bit RGB data bus (DB[17:0]) according to the data enable signal (ENABLE).

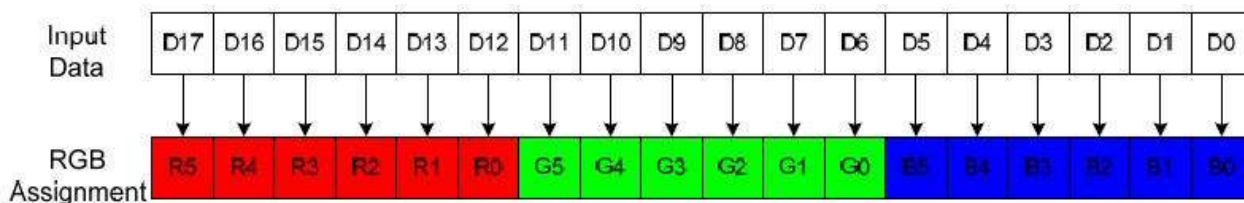

11-3-3) Timing Characteristics

Signal	Symbol	Parameter	min	max	Unit	Description
VSYNC / HSYNC	t_{SYNCS}	VSYNC/HSYNC setup time	15	-	ns	18/16-bit bus RGB interface mode
	t_{SYNCH}	VSYNC/HSYNC hold time	15	-	ns	
ENABLE	t_{ENS}	ENABLE setup time	15	-	ns	
	t_{ENH}	ENABLE hold time	15	-	ns	
DB[17:0]	t_{POS}	Data setup time	15	-	ns	
	t_{POH}	Data hold time	15	-	ns	
DOTCLK	PWDH	DOTCLK high-level period	15	-	ns	
	PWDL	DOTCLK low-level period	15	-	ns	
	t_{CYCD}	DOTCLK cycle time	30	-	ns	
	$t_{\text{r}}, t_{\text{f}}$	DOTCLK, HSYNC, VSYNC rise/fall time	-	15	ns	

Note: $T_a = -30$ to 70 °C, $IOVCC=1.65V$ to $3.3V$, $VCC=2.5V$ to $3.3V$, $AGND=DGND=0V$

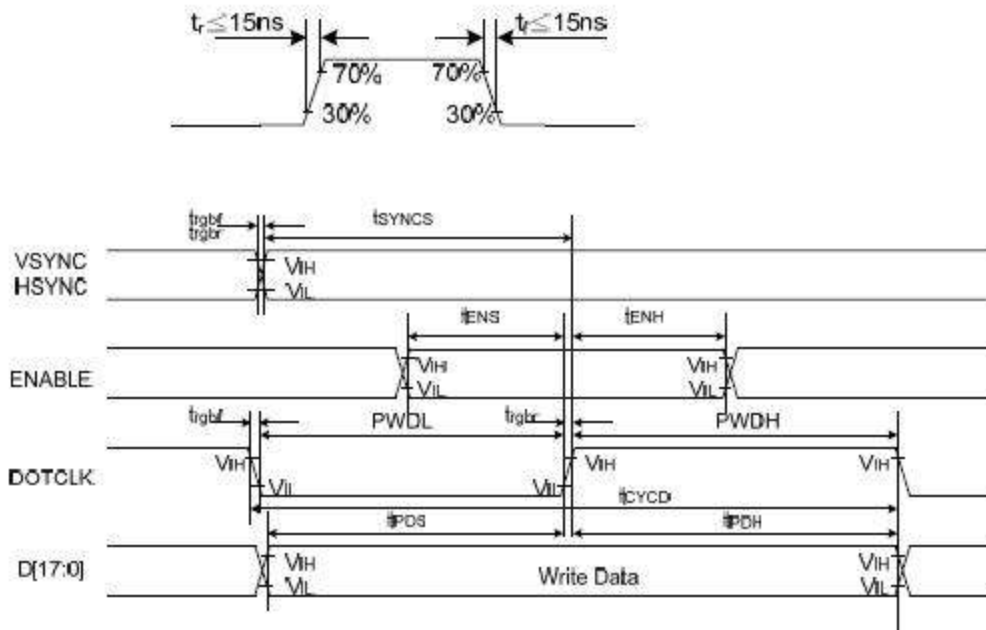

11-4) Display on Flow

```
//power
Init_Data_Comm(0x00C1);
Init_Data_Param(0x0011);
Init_Data_Param(0x004D);
Init_Data_Param(0x000D);

Init_Data_Comm(0x00EA);
Init_Data_Param(0x0000);

Init_Data_Comm(0x00F2);
Init_Data_Param(0x0040);
Init_Data_Param(0x004B);
Init_Data_Param(0x0002);
Init_Data_Param(0x002B);
Init_Data_Param(0x004A);
Init_Data_Param(0x0035);

//Postive Gamma Control
Init_Data_Comm(0x00E0);
```



```
Init_Data_Param(0x0005);
Init_Data_Param(0x000B);
Init_Data_Param(0x0011);
Init_Data_Param(0x0012);
Init_Data_Param(0x0012);
Init_Data_Param(0x001B);
Init_Data_Param(0x000E);
Init_Data_Param(0x000F);
Init_Data_Param(0x0000);
Init_Data_Param(0x0007);
Init_Data_Param(0x0004);
Init_Data_Param(0x0011);
Init_Data_Param(0x0010);
Init_Data_Param(0x0027);
Init_Data_Param(0x0009);
Init_Data_Param(0x0025);
```

```
//Negative Gamma Correction
```

```
Init_Data_Comm(0x00E1);
Init_Data_Param(0x0025);
Init_Data_Param(0x0010);
Init_Data_Param(0x0028);
Init_Data_Param(0x0010);
Init_Data_Param(0x0011);
Init_Data_Param(0x0003);
Init_Data_Param(0x0007);
Init_Data_Param(0x0002);
Init_Data_Param(0x000C);
Init_Data_Param(0x000E);
Init_Data_Param(0x001B);
Init_Data_Param(0x0011);
Init_Data_Param(0x0012);
Init_Data_Param(0x0010);
Init_Data_Param(0x000B);
Init_Data_Param(0x0006);
```

```
DelayX10ms(12);
```

```
//Display Inversion Control
```

```
Init_Data_Comm(0x00b4);
Init_Data_Param(0x0001);
```

```
//display inversion ON
```

```
Init_Data_Comm(0x0021);
```

```
//frame rate control
```

```
Init_Data_Comm(0x00B1);
Init_Data_Param(0x0000);
Init_Data_Param(0x0010);
```

Init_Data_Param(0x0016);

//INTERFACE PIXEL FORMAT

Init_Data_Comm(0x003A);

Init_Data_Param(0x0066);

//Memory Access Control

Init_Data_Comm(0x0036);

Init_Data_Param(0x0008);

Init_Data_Comm(0x00FC);

Init_Data_Param(0x0000);

Init_Data_Param(0x0000);

//VCOM CONTROL 1

Init_Data_Comm(0x00C5);

Init_Data_Param(0x0000);

Init_Data_Param(0x0029);

//Display Function Control

Init_Data_Comm(0x00B6);

Init_Data_Param(0x0032);

Init_Data_Param(0x0082);

Init_Data_Param(0x00FF);

Init_Data_Param(0x0005);

Init_Data_Comm(0x00F7);

Init_Data_Param(0x0088);

Init_Data_Param(0x0080);

Init_Data_Param(0x000D);

Init_Data_Param(0x0009);

Init_Data_Param(0x0006);

DelayX10ms(20);

Init_Data_Comm(0x00F0);

Init_Data_Param(0x0000);

Init_Data_Comm(0x00F9);

Init_Data_Param(0x0002);

//SLEEP OUT

Init_Data_Comm(0x0011);

//Display ON

Init_Data_Comm(0x0029);

//MEMORY WRITE

```
Init_Data_Comm(0x002C);
```

```
//Interface mode control
```

```
Init_Data_Comm(0x002A);
Init_Data_Param(0x0000);
Init_Data_Param(0x0000);
Init_Data_Param(0x0001);
Init_Data_Param(0x00dF);
```

```
Init_Data_Comm(0x002B);
Init_Data_Param(0x0000);
Init_Data_Param(0x0000);
Init_Data_Param(0x0002);
Init_Data_Param(0x007F);
```

```
Init_Data_Comm(0x002C);
```

```
Init_Data_Comm(0x00B0);
Init_Data_Param(0x0001);
```

12. Power On Sequence

TBD

13. Optical Characteristics

13-1) Specification:

Ta=25°C

Parameter		Symbol	Condition	MIN.	TYP.	MAX.	Unit	Remarks
Viewing Angle	Horizontal	$\theta_{22}、\theta_{21}$	CR > 10	(70)	(75)	-	deg	Note 13-1
	Vertical	θ_{12}		(45)	(50)	-	deg	
		θ_{11}		(45)	(50)	-	deg	
Contrast Ratio		CR	At optimized viewing angle	(400)	(450)	-	-	Note 13-2
Response time	Rise	Tr	$\theta = 0^\circ$	-	15	30	ms	Note 13-3
	Fall	Tf		-	10	20	ms	
Brightness		L	$\theta = 0^\circ / \varphi = 0$	--	(500)	-	cd/m ²	
Luminance Uniformity		U	-	(75)	(80)	-	%	Note 13-4
White Chromaticity		x	-	TBD	TBD	TBD	-	
		y	-	TBD	TBD	TBD	-	
Cross Talk		-	$\theta = 0^\circ$	-	-	3.5	%	Note 13-5
LED life time		-	+25°C	TBD	TBD	-	Hr	

All optical measurements shall be performed after backlight being turned-on for 30 mins. The optical characteristics shall be measured in dark room (ambient illumination on panel surface less than 1 Lux). The measuring configuration shows as following figure.

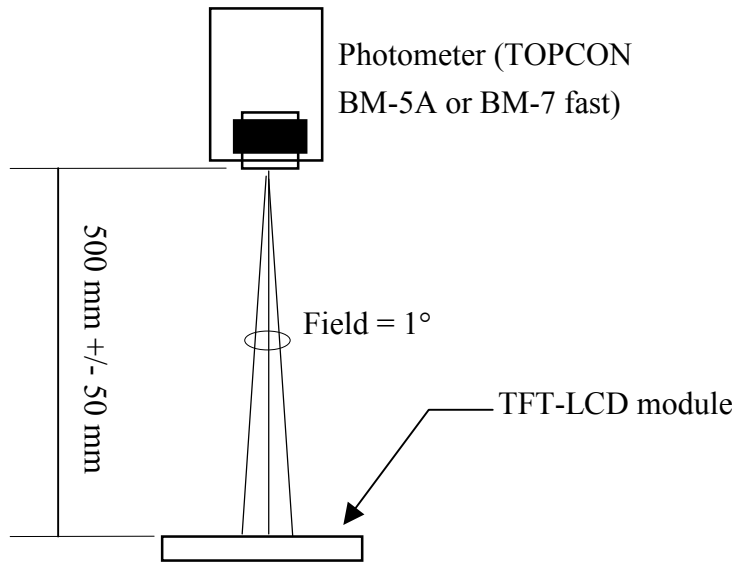

Optical characteristics measuring configuration

Topcon BM-5A or BM-7 fast luminance meter 1° field of view is used in the testing.

Note 13-1: The definitions of viewing angles are as follow

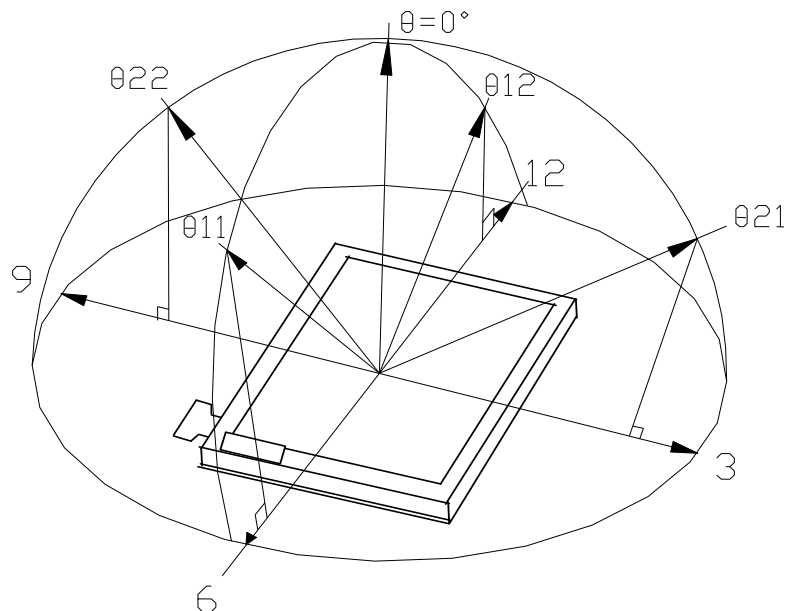

Note 13-2: The definition of contrast ratio $CR = \frac{\text{Luminance at gray level 63}}{\text{Luminance at gray level 0}}$

Note 13-3: Definition of Response Time Tr and Tf:

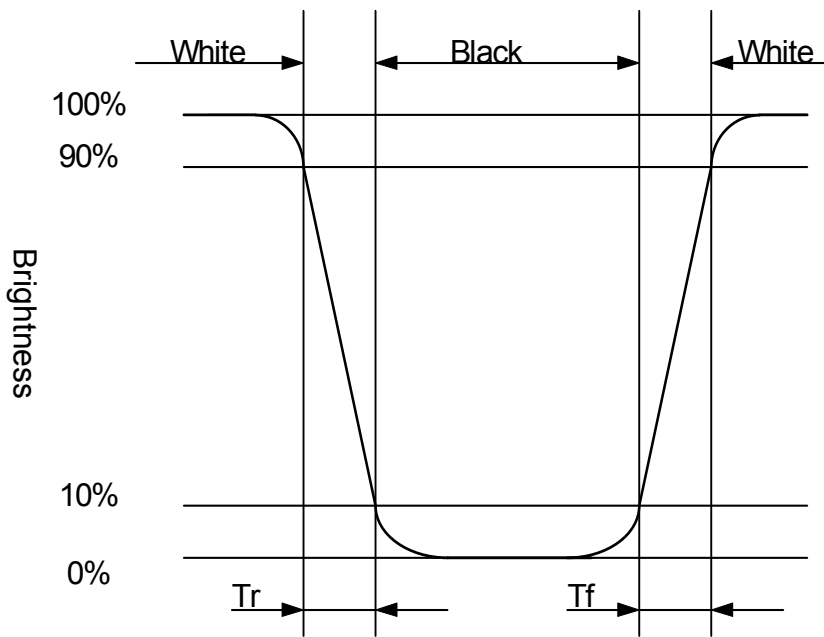

Note 13-4: The uniformity of LCD is defined as

$$U = \frac{\text{The Minimum Brightness of the 9 testing Points}}{\text{The Maximum Brightness of the 9 testing Points}}$$

Luminance meter: BM-5A or BM-7 fast (TOPCON)

Measurement distance: 500 mm +/- 50 mm

Ambient illumination: < 1 Lux

Measuring direction: Perpendicular to the surface of module

The test pattern is white (Gray Level 63).

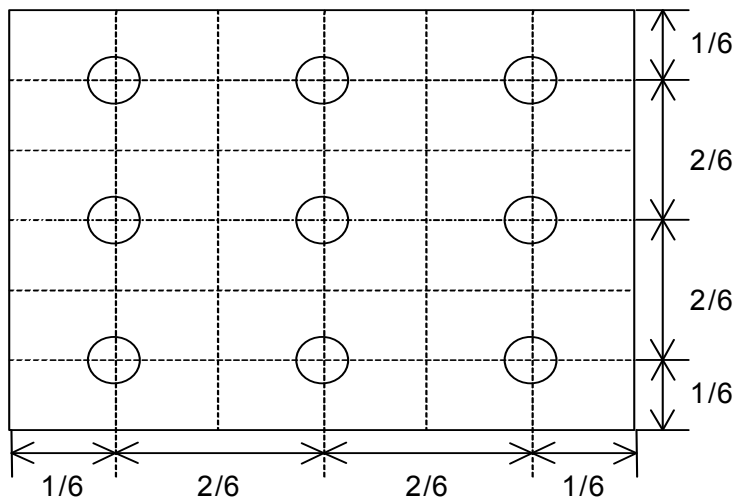

Note 13-5: Cross Talk (CTK) = $\frac{|Y_A - Y_B|}{Y_A} \times 100\%$

YA: Brightness of Pattern A

YB: Brightness of Pattern B

Luminance meter: BM-5A or BM-7 fast (TOPCON)

Measurement distance: 500 mm +/- 50 mm

Ambient illumination: < 1 Lux

Measuring direction: Perpendicular to the surface of module

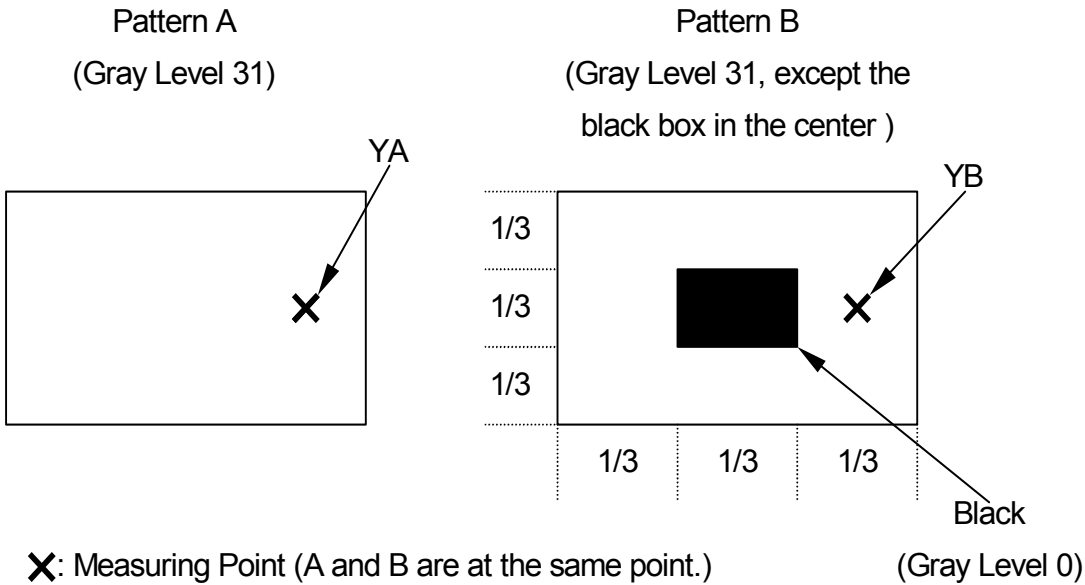

14. Handling Cautions

14-1) Mounting of module

- a) Please power off the module when you connect the input/output connector.
- b) Polarizer which is made of soft material and susceptible to flaw must be handled carefully.
- c) Protective film (Laminator) is applied on surface to protect it against scratches and dirt. It is recommended to peel off the laminator before use and taking care of static electricity.
- d) Please following the tear off direction as figure 14-1 to remove the protective film as slowly as possible, so that electrostatic charge can be minimized.

14-2) Precautions in mounting

- a) When metal part of the TFT-LCD module (shielding lid and rear case) is soiled, wipe it with soft dry cloth.
- b) Wipe off water drops or finger grease immediately. Long contact with water may cause discoloration or spots.
- c) TFT-LCD module uses glass which breaks or cracks easily if dropped or bumped on hard surface. Please handle with care.
- d) Since CMOS LSI is used in the module. So take care of static electricity and earth yourself when handling.

14-3) Adjusting module

- a) Adjusting volumes on the rear face of the module have been set optimally before shipment.
- b) Therefore, do not change any adjusted values. If adjusted values are changed, the specifications described may not be satisfied.

14-4) Others

- a) Do not expose the module to direct sunlight or intensive ultraviolet rays for many hours.
- b) Store the module at a room temperature place.
- c) The voltage of beginning electric discharge may over the normal voltage because of leakage current from approach conductor by to draw lump read lead line around.
- d) If LCD panel breaks, it is possibly that the liquid crystal escapes from the panel. Avoid putting it into eyes or mouth. When liquid crystal sticks on hands, clothes or feet. Wash it out immediately with soap.
- e) Observe all other precautionary requirements in handling general electronic components.
- f) Please adjust the voltage of common electrode as material of attachment by 1 module.

14-5) Polarizer mark

The polarizer mark is to describe the direction of wide view angle film how to match up with the rubbing direction.

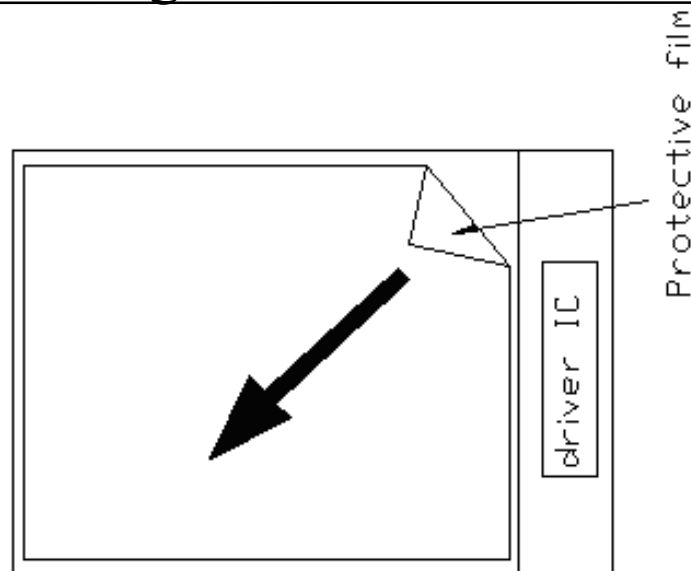

Figure 14-1 the way to peel off protective film

15. Reliability Test

No	Test Item	Test Condition
1	High Temperature Storage Test	Ta = +80°C, 240 hrs
2	Low Temperature Storage Test	Ta = -30°C, 240 hrs
3	High Temperature Operation Test	Ta = +70°C, 240 hrs
4	Low Temperature Operation Test	Ta = -20°C, 240 hrs
5	High Temperature & High Humidity Operation Test	Ta = +60°C, 90%RH, 240 hrs (No Condensation)
6	Thermal Cycling Test (non-operating)	-30°C → +80°C, 100 Cycles 30min 30min
7	Vibration Test (non-operating)	Frequency : 10 ~ 55 Hz Amplitude : 1 mm Sweep time: 11 mins Test Period: 6 Cycles for each direction of X, Y, Z
8	Shock Test (non-operating)	100G, 6ms Direction: ±X, ±Y, ±Z Cycle: 3 times
9	Electrostatic Discharge Test (non-operating)	200pF, 0Ω ±200V 1 time / each terminal

[Criteria]

1. In the standard conditions, there is not display function NG issue occurred. (including :line defect ,no image)
All the cosmetic specification is judged before the reliability stress

16. Packing Diagram

TBD