

DATA IMAGE CORPORATION

TFT Module Specification

ITEM NO.: FG100131DNSWAG02

Table of Contents

1. COVER & CONTENTS	1
2. RECORD OF REVISION.....	2
3. GENERAL DESCRIPTIONS	3
4. ABSOLUTE MAXIMUM RATING.....	5
5. PIXEL FORMAT IMAGE	6
6. OPTICAL CHARACTERISTICS	7
7. BACKLIGHT CHARACTERISTICS	10
8. ELECTRICAL CHARACTERISTICS	10
9. INTERFACE TIMINGS	15
10. POWER CONSUMPTION	16
11. POWER ON/OFF SEQUENCE	16
12. TOUCH PANEL CHARACTERISTICS.....	17
13. LCM PRODUCT LABEL DEFINE.....	18
14. PRECAUTIONS IN USE LCM	20
15. OUTLINE DRAWING	21
16. PACKAGE INFORMATION	22

Customer Companies	R&D Dept.	Q.C. Dept.	Eng. Dept.	Prod. Dept.
	JACK	JOE	GARY	KEN
Approved by	Version:	Issued Date:	Sheet Code:	Total Pages:
	B	13/JUN/12'		22

2. RECORD OF REVISION

Rev	Date	Item	Page	Comment
1	23/NOV/10'			Initial Preliminary
2	13/JAN/11'	15	22	Modify outline drawing
A	31/OCT/11'	3.3 3.4 6 8.3.1 9 10 14 15 16	3 4 7 12 15 16 20 21 22	1. Modify power consumption. 2. Modify functional block diagram. 3. Add contrast ratio min. value, RGB color chromaticity and white luminance min. value. 4. Add note B clock frequency min. and max. value. 5. Modify Interface timings. 6. Add IDD and PDD data. 7. Modify precautions in use LCM. 8. Modify outline drawing rev:2 to rev:A. 9. Add package information
B	13/JUN/12'	7	10	Modify LED life time.

3. General Descriptions

3.1 Introduction

The FG100131DNSWAG02 is a color active matrix thin film transistor (TFT) liquid crystal display(LCD) that uses amorphous silicon TFT as a switching device. It is composed of a TFT LCD panel, a timing controller, voltage reference, common voltage, column driver, and row driver circuit. This TFT LCD has a 10.1-inch diagonally measured active display area with WSVGA resolution (1,024vertical by 600 horizontal pixel array).

3.2 Features

- 10.1" TFT LCD Panel
- LED Light-bar Backlight System
- Supported WSVGA (V:1024 lines, H:600 pixels) Resolution
- Compatible with RoHS Standard
- Dual Gate

3.3 Product Summary

Items	Specifications	Unit
Screen Diagonal	10.1	Inch
Active Area	222.72(H) x 125.28(V)	mm
Pixels H x V	1,024 (x3)x 600	-
Pixel Pitch	0.2175(H)x0.2088(V)	mm
Pixel Arrangement	R.G.B. Vertical Stripe	-
Display Mode	Normally White	-
White Luminance	320 (Typ.) 5 points average	cd/m ² (20mA of per LED)
Contrast Ratio	400 (Typ.)	-
Response Time	16 (Typ.)	ms
View Angle(L/R/U/D)	45/45/15/35(Typ.)	-
Input Voltage	+3.3 (Typ.)	V
Power Consumption	4.064(Max)	Watt
Module Weight	300	g
Outline Dimension	235 (H)x 143(W) x 6.5(D)	mm
Electrical Interface (Logic)	LVDS	-
Support Color	262 K	-
Color Gamut	45%(Typ.)	-
Optimum Viewing Direction	6 o'clock	-
Surface Treatment	Anti-Glare	-

3.4 Functional Block Diagram

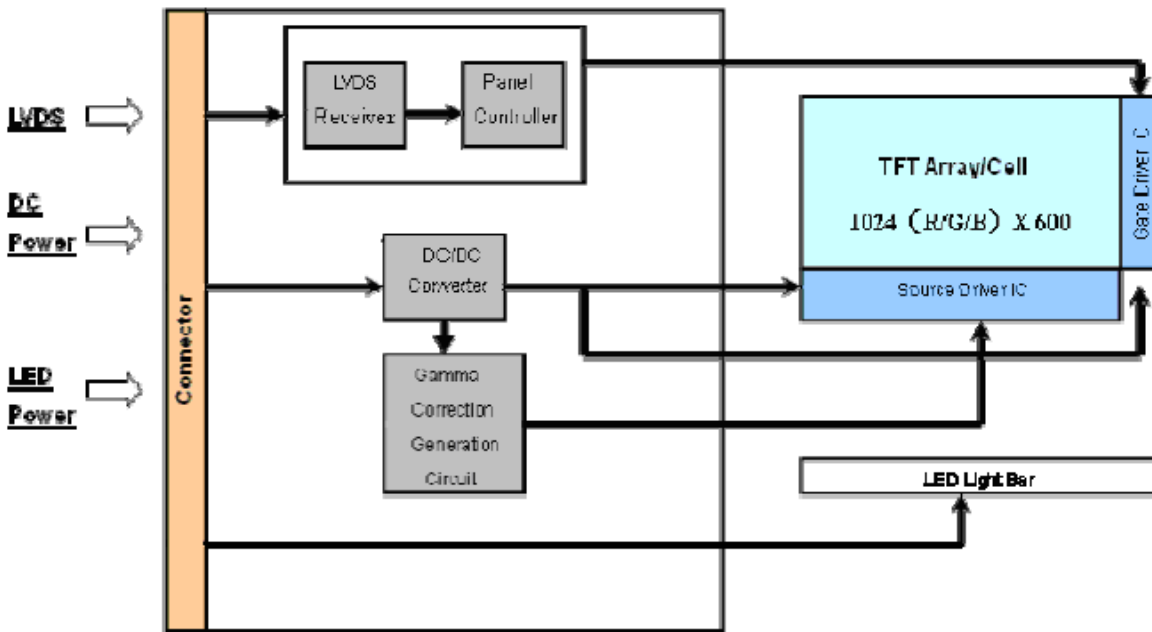

Figure 1 shows the functional block diagram of the LCD module.

4. Absolute Maximum Ratings

Item	Symbol	Min	Max	Unit	Conditions
Supply Voltage	VDD	-0.3	4.0	V	Typ.=3.3V
Input Signal		-0.3	2.7	V	LVDS signals
Operating Temperature	TOP	0	50	°C	(Note 3)
Operating Humidity	HOP	10	80	% RH	(Note 3)
Storage Temperature	TST	-20	60	°C	(Note 3)
Storage Humidity	HST	10	90	% RH	(Note 3)
Vibration			1.5G	G	30min for X, Y, Z axis
			10~500Hz	Hz	
Shock			220	G	Half sign wave
			2	mS	
LED Current	I-LED		20	mA	per LED

Note:

- (1) Maximum Wet-Bulb should be 39°C. No condensation.
- (2) When you apply the LCD module for OA system. Please make sure to keep the temperature of LCD module is less than 60°C.
- (3) Storage /Operating temperature

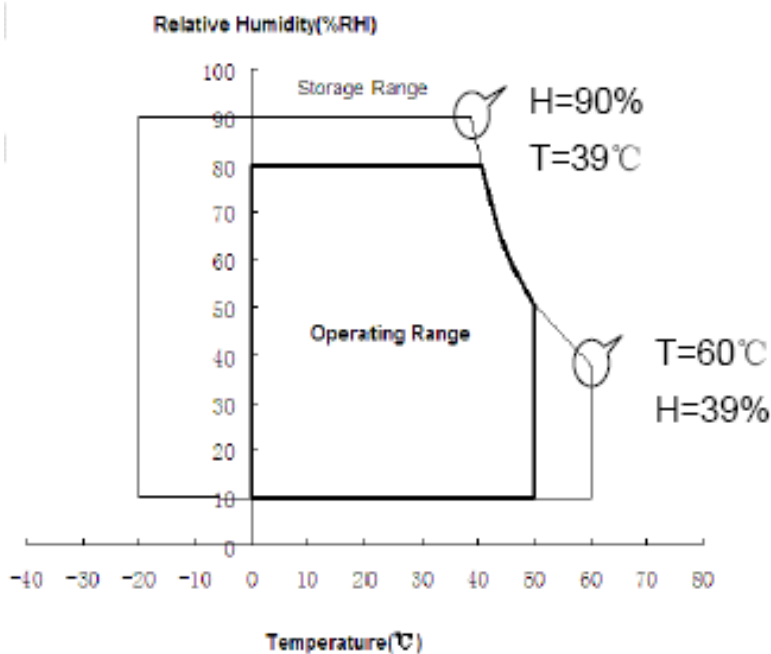

6. Optical Characteristics

The optical characteristics are measured under stable conditions as following notes

Item	Conditions		Specification			
			Min	Typ.	Max	Note
Viewing Angle [degrees] K=Contrast Ratio>10	Horizontal	Left	35	45	-	A, B
		Right	35	45	-	
	Vertical	Up	5	15	-	
		Down	25	35	-	
Contrast ratio	Center		300	400	-	A, C
Response Time [ms]	Rising + Falling		-	16		A, D
Color Chromaticity (CIE1931)	Red	x	Typ. -0.05	0.582	Typ. +0.05	A,
	Red	y		0.345		A,
	Green	x		0.336		A,
	Green	y		0.555		A,
	Blue	x		0.155		A,
	Blue	y		0.122		A,
	White	x	0.263	0.313	0.365	A,
	White	y	0.279	0.329	0.379	A,
White Luminance [cd/m ²]	I-LED=20mA		250	320	-	5 point A, E
Luminance Uniformity [%]	I-LED=20mA , 13points		68	-	-	A, F
	I-LED=20mA , 5points		80.0	-	-	

Note: A. Measurement Setup:

The LCD module should be stabilized at given temperature for 15 minutes to avoid abrupt temperature change during measuring. In order to stabilize the luminance, the measurement should be executed after lighting backlight for 15 minutes in a windless room.

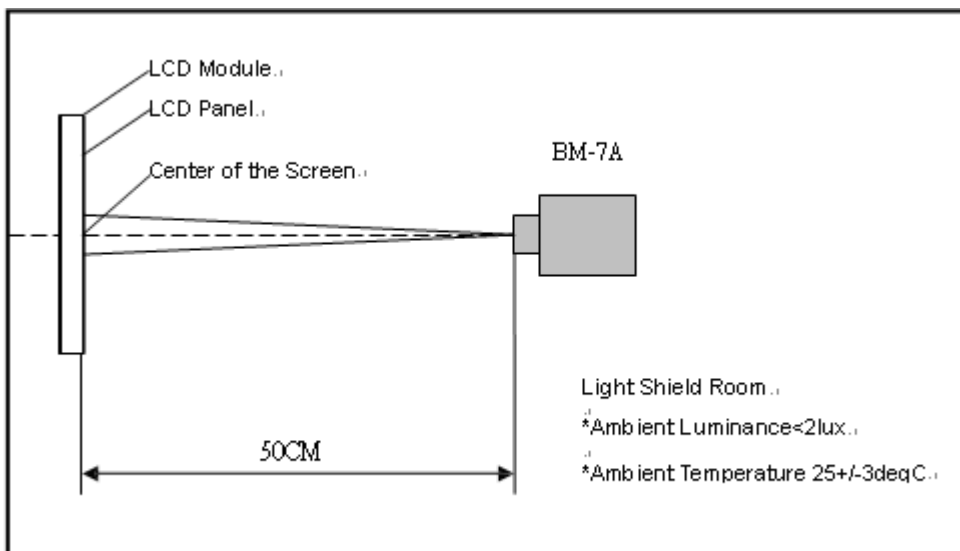

Figure 3 Measurement Setup

B. Definition of Viewing Angle

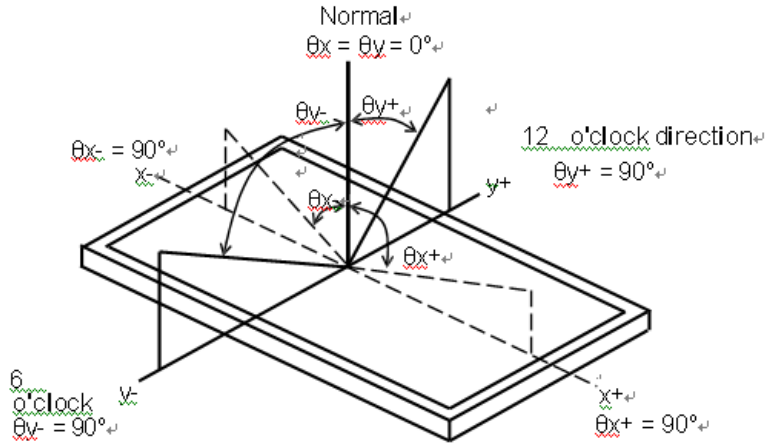

Figure 4 Definition of Viewing Angle

C. Definition of Contrast Ratio (CR)

The contrast ratio can be calculated by the following expression

$$\text{Contrast Ratio (CR)} = L63 / L0$$

L63: Luminance of gray level 63, L0: Luminance of gray level 0

D. Definition of Response Time (T_R, T_F)

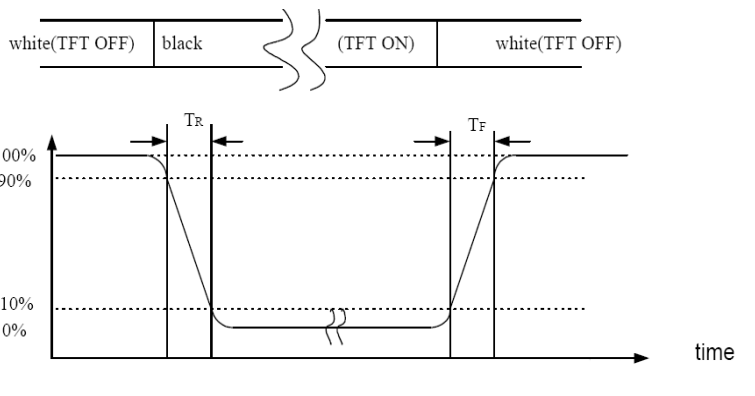

Figure 5 Definition of Response Time

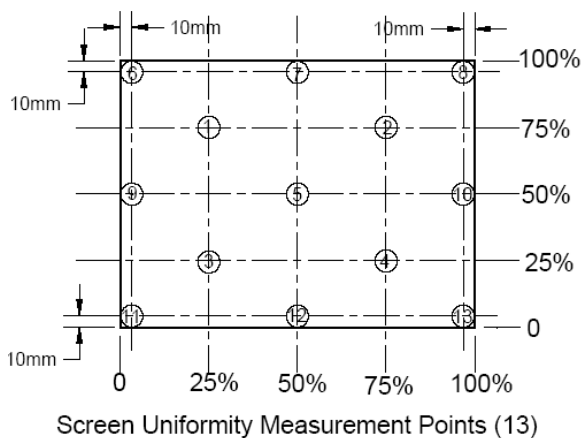

Figure 6 Measurement Locations of 13 Points

E. Definition of Luminance White

Measure the luminance of gray level 63 at center point and 5 points.

Center of Luminance = Y5

$$\text{Average Luminance of 5 points} = \frac{Y1+Y2+Y3+Y4+Y5}{5}$$

F. Definition of Luminance Uniformity (Variation)

Measure the luminance of gray level 63 at 13 points.

$$\text{Uniformity of 13 points} = \frac{\text{Min Luminance of } Y1\sim Y13}{\text{Max Luminance of } Y1\sim Y13} \times 100\%$$

$$\text{Uniformity of 5 points} = \frac{\text{Min Luminance of } Y1\sim Y5}{\text{Max Luminance of } Y1\sim Y5} \times 100\%$$

7. Backlight Characteristics

7.1 Parameter Guideline of LED Backlight

Symbol	Parameter	Min.	Typ.	Max.	Units	Condition
V_L	LED Light bar Driving (Row output)	8.7	9.6	10.2	V	Ta=25°C Note A ,Note C
I_L	LED Current	--	320	--	mA	Ta=25°C
LT	LED Life Time	30,000	--	--	Hours	Ta=25°C Note B ,Note C

Note A: $I_{LED}=20$ mA (Per LED)

Note B: The LED life time define as the estimated time to 50% degradation of initial luminous.

Note C: under room temperature(25°C , Humidity 30-60% RH) and $I_L=320$ mA.

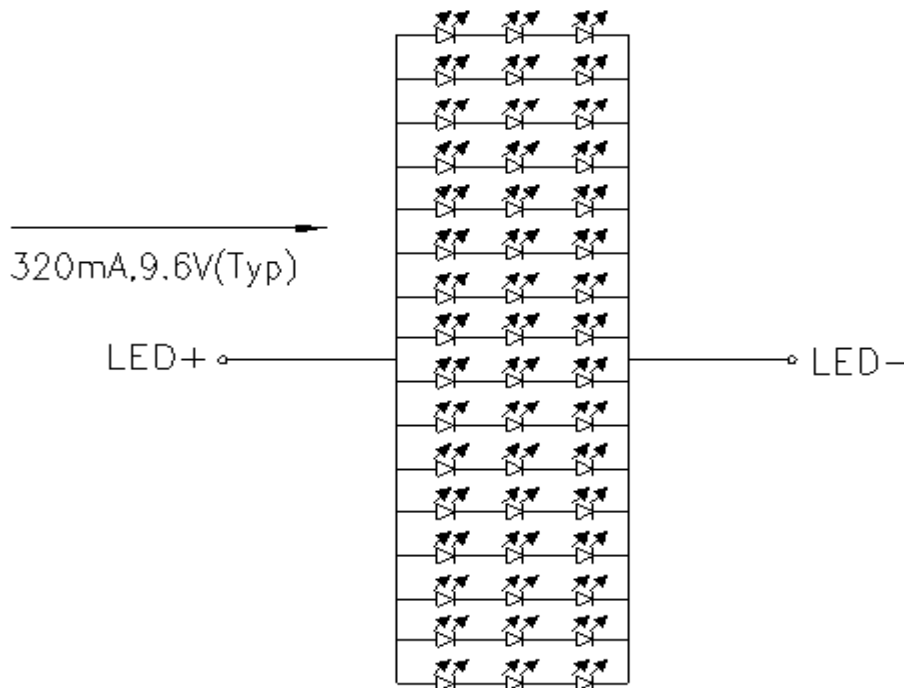

8. ELECTRICAL CHARACTERISTICS

8.1 Interface Connector

Manufacturer	UJU (or equivalent)
Type / Part Number	IS050-L40B-C10

8.2 B/L Connector

Manufacturer	
Type / Part Number	H208K-P02N-02B

Signal Pin Assignment

Pin #	Signal Name	Description	Remarks
1	GND	Ground	
2	VDD	Power supply 3.3V(Typ.)	
3	VDD	Power supply 3.3V(Typ.)	
4	VEDID	EDID +3.3V Power	
5	BIST	Bist Mode	Reserve for Aging
6	CLK_EDID	EDID Clock Input	
7	DAT_EDID	EDID Data Input	
8	Rin0-	-LVDS differential data input(R0-R5,G0)	
9	Rin0+	+LVDS differential data input(R0-R5,G0)	
10	GND	Ground	
11	Rin1-	-LVDS differential data input(G1-G5,B0-B1)	
12	Rin1+	+LVDS differential data input(G1-G5,B0-B1)	
13	GND	Ground	
14	Rin2-	-LVDS differential data input(B2-B5,HS,VS,DE)	
15	Rin2+	+LVDS differential data input(B2-B5,HS,VS,DE)	
16	GND	Ground	
17	CLKN-	-LVDS differential clock input	
18	CLKN+	+LVDS differential clock input	
19	NC	Not connected(Reserve)	
20	NC	Not connected(Reserve)	
21	NC	Not connected(Reserve)	
22	GND	Ground	
23	NC	Not connected(Reserve)	
24	NC	Not connected(Reserve)	
25	GND	Ground-Shield	
26	NC	Not connected(Reserve)	
27	NC	Not connected(Reserve)	
28	GND	Ground-Shield	
29	NC	Not connected(Reserve)	
30	NC	Not connected(Reserve)	
31	NC(VLED_GND)	No connected (LED Ground)	
32	NC(VLED_GND)	No connected (LED Ground)	
33	NC(VLED_GND)	No connected (LED Ground)	
34	NC	Not connected(Reserve)	
35	NC (VPWM_EN)	Not connected(System PWM Logic Input Level)	
36	NC(VLED_EN)	Not connected(LED enable Input Level(+3.3V))	
37	NC	Not connected(Reserve)	
38	NC(VLED)	No connected (LED Power Supply 5+/-0.5V)	
39	NC(VLED)	No connected (LED Power Supply 5+/-0.5V)	
40	NC(VLED)	No connected (LED Power Supply 5+/-0.5V)	

All input signals shall be low or Hi-Z state when VDD is off

8.3 LVDS Receiver

8.3.1 Signal Electrical Characteristics for LVDS Receiver

The built-in LVDS receiver is compatible with (ANSI/TIA/TIA-644) standard.

Parameter	Symbol	Min	Typ.	Max	Unit	Conditions
Differential Input High Threshold	V_{th}	-	-	+100	mV	$V_{cm}=+1.2V$
Differential Input Low Threshold	V_{tl}	-100	-	-	mV	$V_{cm}=+1.2V$
Magnitude Differential Input Voltage	$ V_{id} $	100	-	600	mV	
Common Mode Voltage	V_{cm}	0.9	1.2	1.5	V	
Common Mode Voltage Offset	ΔV_{cm}	-	-	50	mV	$V_{cm}=+1.2V$

Note:

- A. Input signals shall be low or Hi-Z state when VDD is off.
- B. All electrical characteristics for LVDS signal are defined and shall be measured at the interface connector of LCD.

Parameter	Symbol	Min	Typ.	Max	Unit	Conditions	Note
Clock Frequency	F_c	44.4	50.4	65.2	MHz		

Note: All values are at $V_{DD}=3.3V$, $T_a=25^\circ C$.

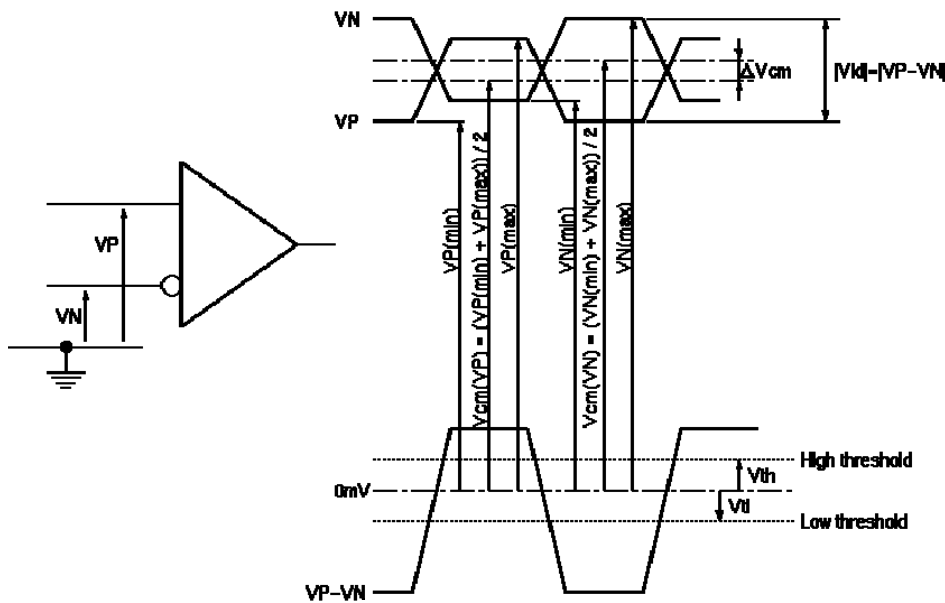

Figure 7 Voltage Definitions

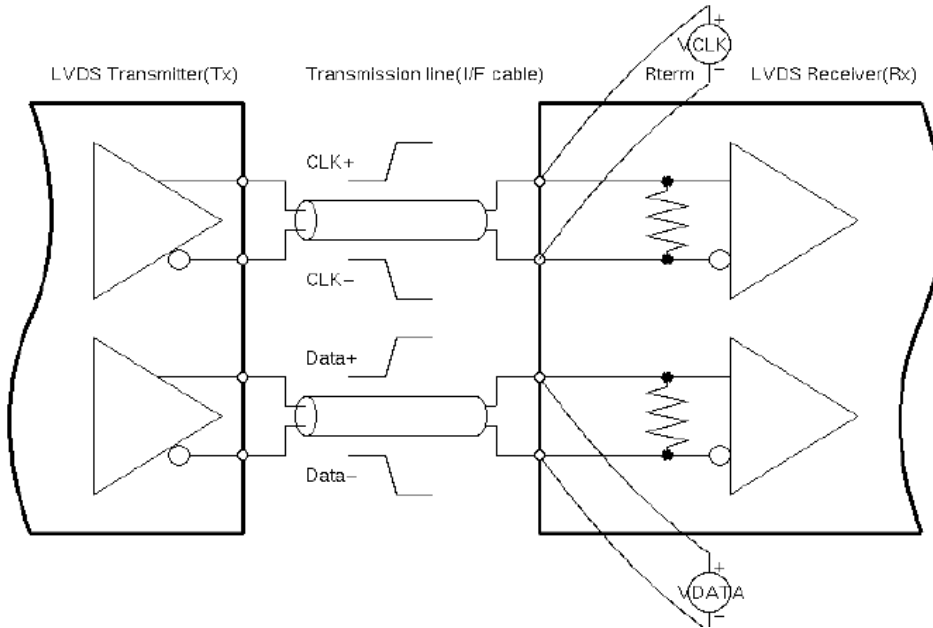

Figure 8 Measurement System

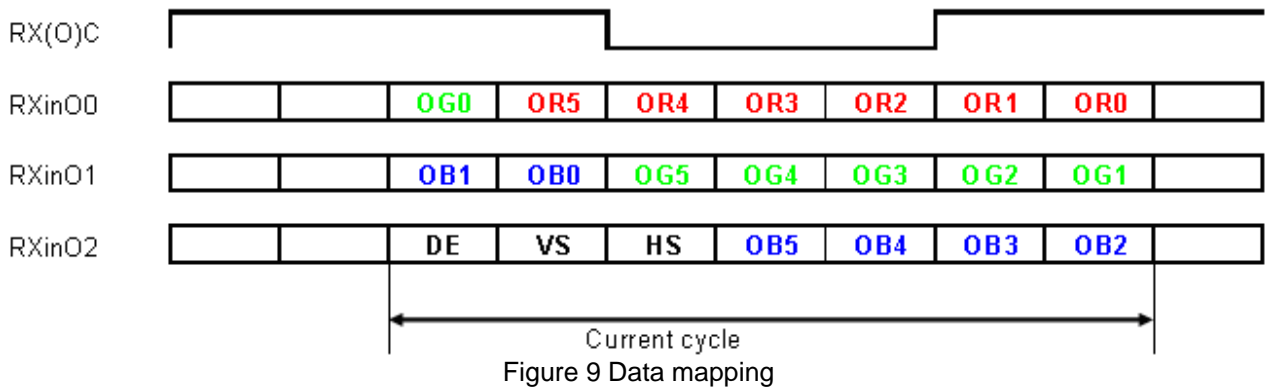

Figure 9 Data mapping

Detail A

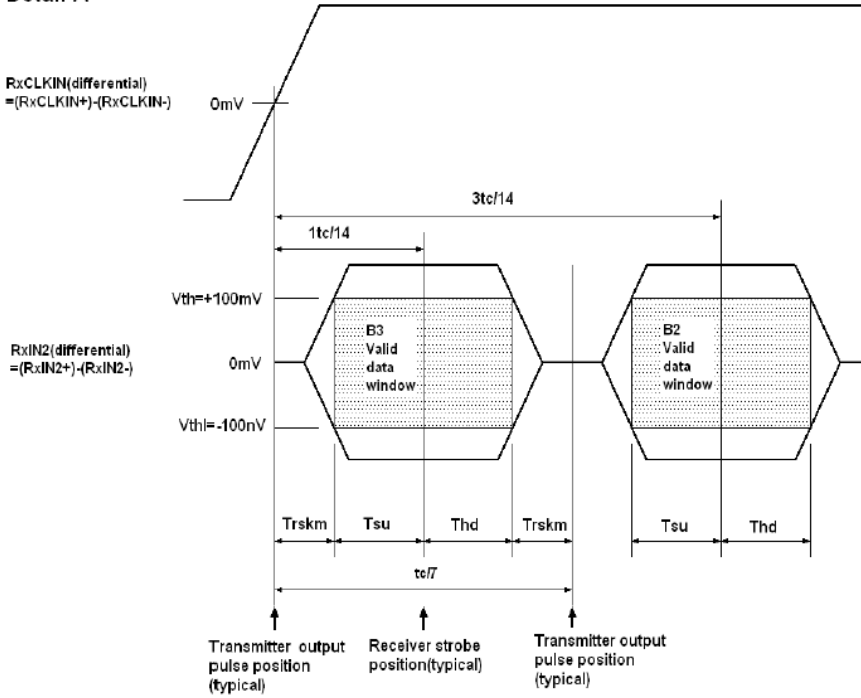

Figure 10 Timing Definition

Note: Tsu and Thd is internal data sampling window of receiver. $Trskm$ is the system skew margin; i.e., the sum of cable skew, source clock jitter, and other inter-symbol interference, shall be less than $Trskm$.

8.3.2 LVDS Receiver Internal Circuit

Figure 11 LVDS Receiver Internal Circuit shows the internal block diagram of the LVDS receiver. This LCD module equips termination resistors for LVDS link.

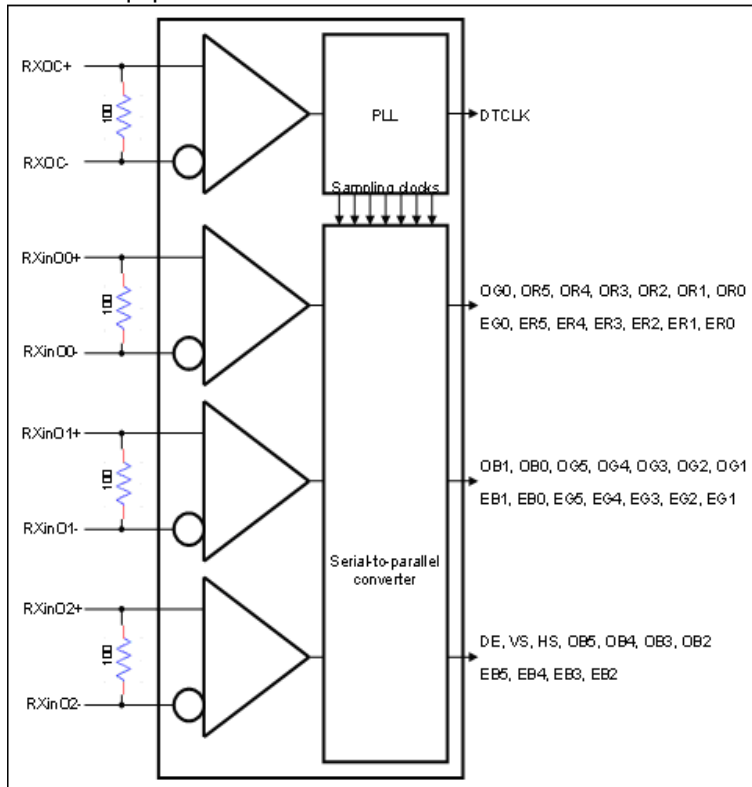

Figure 11 LVDS Receiver Internal Circuit

9. Interface Timings

9.1 Timing Characteristics

Parameter	Symbol	Unit	min	Typ.	Max
LVDS Clock Frequency(single)	Fdck	MHz	44.4	50.4	65.2
H Total Time	Htotal	clocks	1320	1344	1362
H Active Time	Hac	clocks	--	1024	--
V Total Time	Vtotal	lines	612	625	638
V Active Time	Vac	lines	--	600	--
Frame Rate	Vsync	Hz	55	60	65

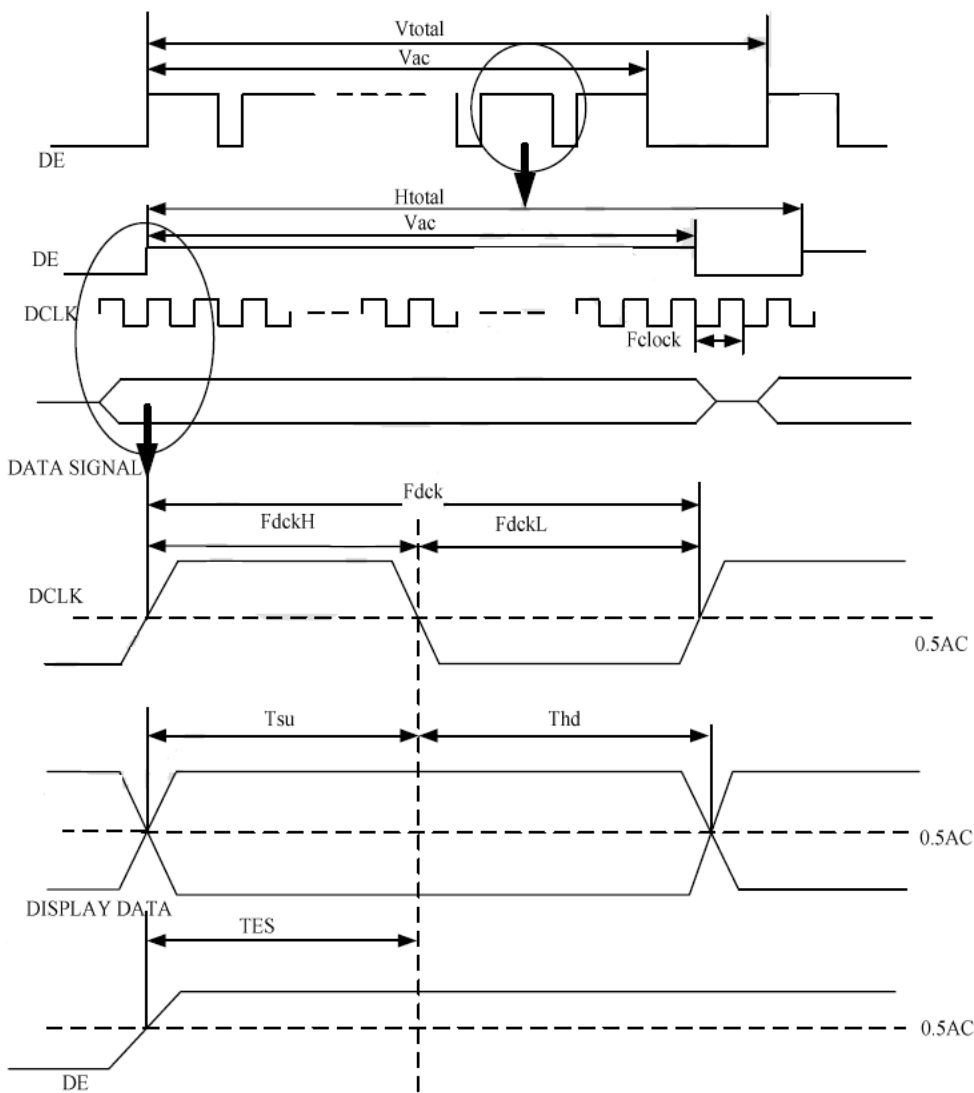

Figure 12 Timing Characteristics

Note: TES is data enable signal setup time.

10. Power Consumption

Input power specifications are as follows.

Symbol	Parameter	Min	Typ.	Max	Units	Condition
VDD	Logic/LCD Drive Voltage	3.0	3.3	3.6	V	
IDD	VDD Current	--	0.18	--	A	All black pattern, 60Hz
PDD	VDD Power	--	--	0.8	W	Max pattern, 60Hz
Irush	Rush Current	--	--	2	A	
VDDrp	Allowable Logic/LCD Drive Ripple Voltage	--	--	300	mVp-p	

11. Power ON/OFF Sequence

VDD power, interface signals, and lamp on/off sequence are shown in Figure 13. Signals shall be Hi-Z state or low level when VDD is off.

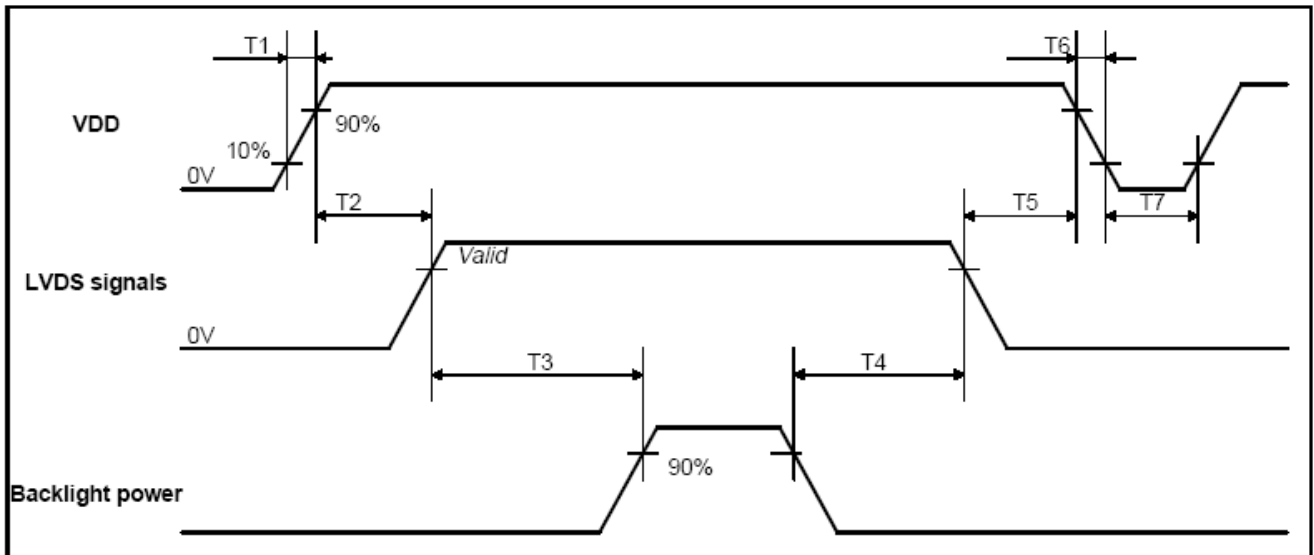

Figure 13 Power Sequence

Parameter	Symbol	min	Typ.	max	Unit
VDD Rise Time	T1	0.5	--	10	ms
VDD Good to Signal Valid	T2	0	--	50	ms
Signal Valid to Backlight On	T3	200	--	--	ms
Backlight Off to Signal Disable	T4	200	--	--	ms
Signal Disable to Power Down	T5	0	--	50	ms
VDD Fall Time	T6	0	--	10	ms
Power Off	T7	400	--	--	ms

12. TOUCH PANEL CHARACTERISTICS

1. Input Method and Activation Force

Input Method	Average Activation Force
0.8mm dia. Delrin Polyacetal staylus	50gf(Max.)

2. Typical Optical Characteristics

ITEM	Parameter
Visible Light Transmission	80% Typ
Haze	5% Type
Hardness of surface	3H

3. Electrical Specification

ITEM	Parameter
Operating Voltage	DC 7V Max
Circuit close resistance	X 500~1650Ω
	Y 70~750Ω
Circuit open resistance	≥20MΩ at 25V DC
Contact bounce	≤10ms
Linear Test	≤1.5%

4. Linearity

ITEM	Parameter
Linear Test Specification Direction	X ≤±1.5%
	Y ≤±1.5%

5. Specification

ITEM	Parameter
Operating Temperature	-20°C~+60°C
Storage Temperature	-40°C~+70°C

6. Durability test:

6.1 Touch panel is hit 1 millions times with a silicone rubber of R8 finger, hitting rate is by 250g at 2 times per second. The measurement must satisfy the following:

- Circuit close resistance: x500~1650Ω ;
y 70~750Ω
- Circuit open resistance: ≥20MΩ at 25V DC
- Contact bounce: ≤10ms
- Linearity test: ≤3.0%

6.2 Stylus writing

Touch panel is drawn by R0.8 Delrin stylus pen, at 250g forces, repeat one inch by 100k times. The measurement must satisfy the following:

- Circuit close resistance: x 500~1650Ω ;
y 70~750Ω
- Circuit open resistance: ≥ 20MΩ at 25V DC
- Contact bounce: ≤10ms
- Linearity test: ≤3.0%

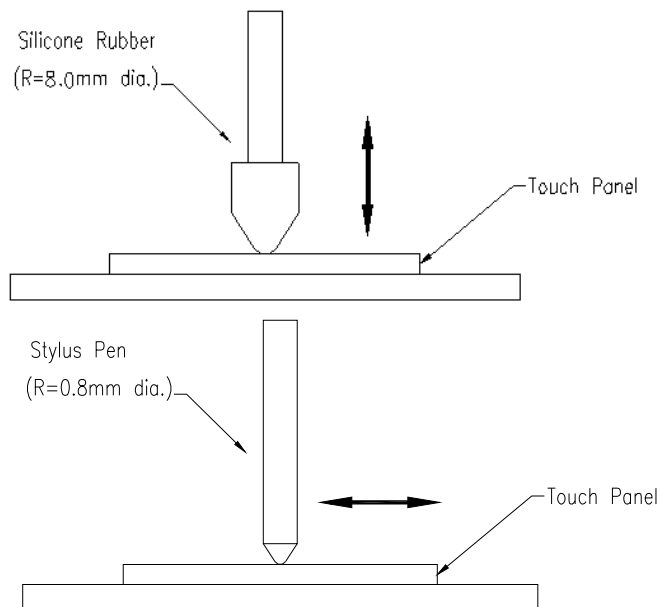

13. LCM PRODUCT LABEL DEFINE

Product Label style:

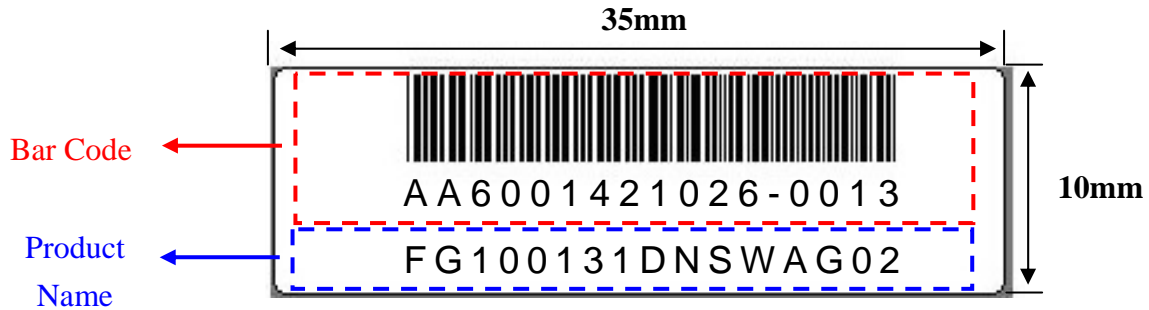

BarCode Define:

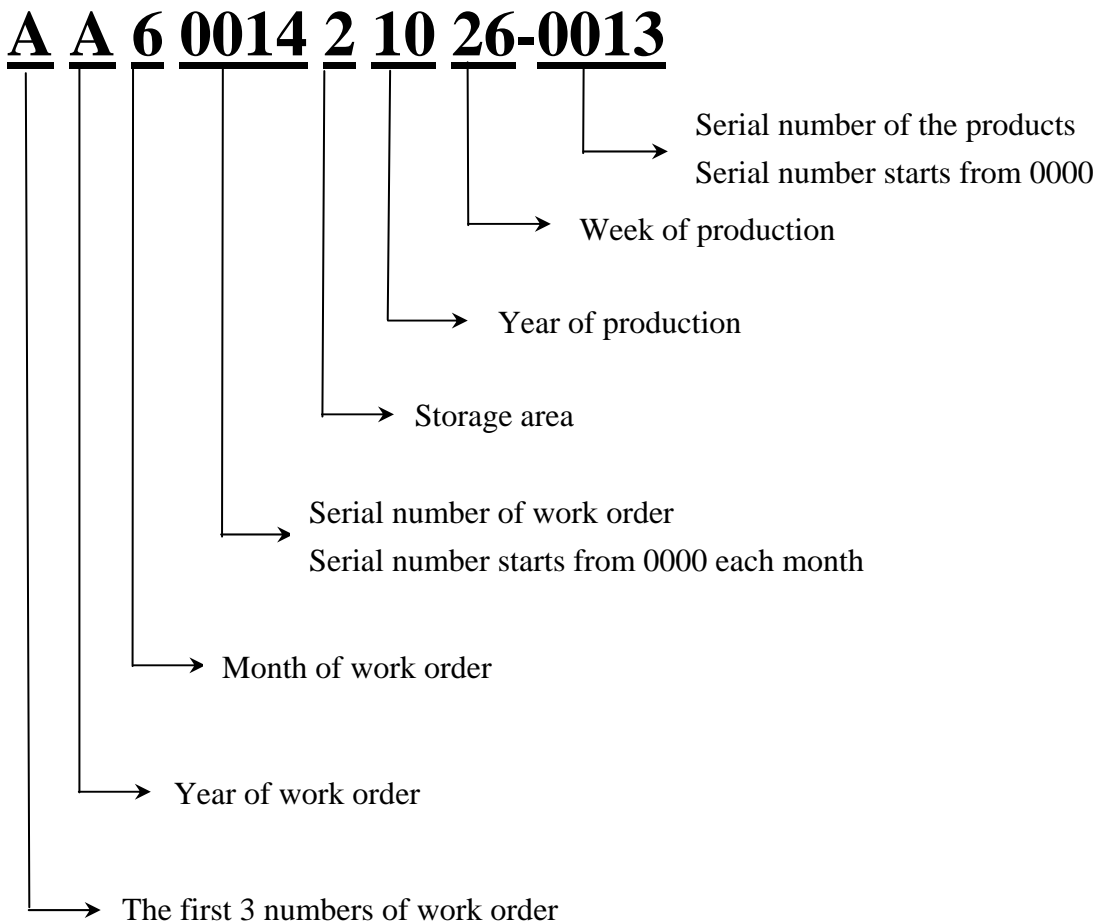

Product Name Define:

FG 100131 D N S W A G 02

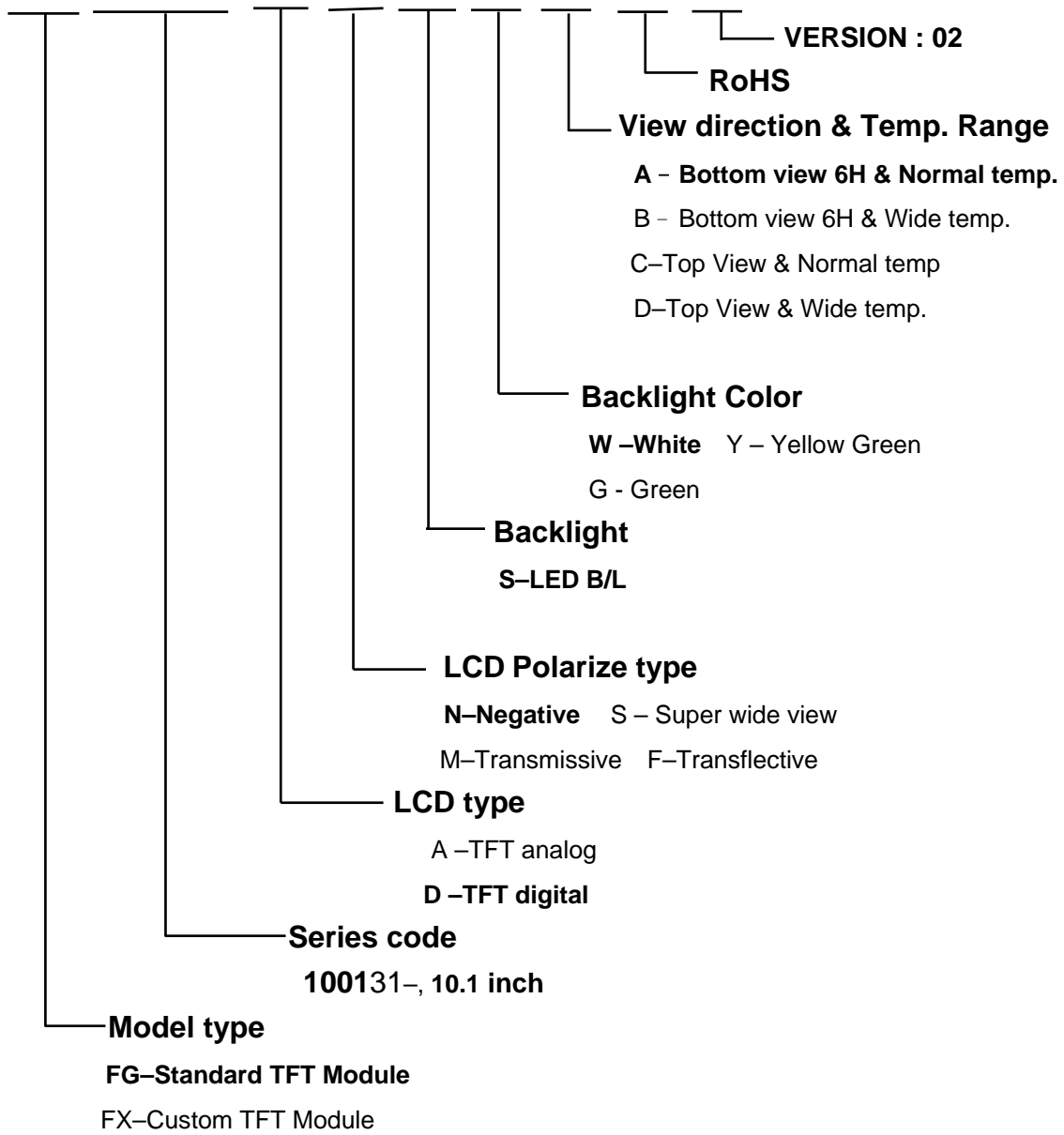

14. PRECAUTIONS IN USE LCM

1. ASSEMBLY PRECAUTIONS

- (1) You must mount a module using holes arranged in four corners or four sides.
- (2) You should consider the mounting structure so that uneven force (ex. Twisted stress) is not applied to the module. And the case on which a module is mounted should have sufficient strength so that external force is not transmitted directly to the module.
- (3) Do not touch, push or rub the exposed polarizers with glass, tweezers or anything harder than HB pencil lead. And please do not rub with dust clothes with chemical treatment.
- (4) Wipe off saliva or water drops as soon as possible. Their long time contact with polarizer causes deformations and color fading.
- (5) Do not open the case because inside circuits do not have sufficient strength.
- (6) Please do not take a LCD module to pieces and reconstruct it. Resolving and reconstructing modules may cause them not to work well.
- (7) Please do not touch metal frames with bare hands and soiled gloves. A color change of the metal frames can happen during a long preservation of soiled LCD modules.
- (8) Please pay attention to handling lead wire of backlight so that it is not tugged in connecting with inverter.

2. OPERATING PRECAUTIONS

- (1) Please be sure to turn off the power supply before connecting and disconnecting signal input cable.
- (2) Please do not change variable resistance settings in LCD module. They are adjusted to the most suitable value. If they are changed, it might happen LCD does not satisfy the characteristics specification
- (3) Be careful for condensation at sudden temperature change. Condensation makes damage to polarizer or electrical contacted parts. And after fading condensation, smear or spot will occur.
- (4) When fixed patterns are displayed for a long time, remnant image is likely to occur.
- (5) Module has high frequency circuits. Sufficient suppression to the electromagnetic interference shall be done by system manufacturers. Grounding and shielding methods may be important to minimize the interference.
- (6) Please consider that LCD backlight takes longer time to become stable of radiation characteristics in low temperature than in room temperature.

3. ELECTROSTATIC DISCHARGE CONTROL

- (1) The operator should be grounded whenever he/she comes into contact with the module. Never touch any of the conductive parts such the copper leads on the PCB and the interface terminals with any parts of the human body.

- (2) The modules should be kept in antistatic bags or other containers resistant to static for storage.
- (3) Only properly grounded soldering irons should be used.
- (4) If an electric screwdriver is used, it should be well grounded and shielded from commutator sparks.
- (5) The normal static prevention measures should be observed for work clothes and working benches; for the latter conductive (rubber) mat is recommended
- (6) Since dry air is inductive to statics, a relative humidity of 50-60% is recommended.

4. STORAGE PRECAUTIONS

- (1) When you store LCDs for a long time, it is recommended to keep the temperature between 0°C-40°C without the exposure of sunlight and to keep the humidity less than 90%RH.
- (2) Please do not leave the LCDs in the environment of high humidity and high temperature such as 60°C 90%RH
- (3) Please do not leave the LCDs in the environment of low temperature; below -20°C.

5. OTHERS

- (1) A strong incident light into LCD panel might cause display characteristics' changing inferior because of polarizer film, color filter, and other materials becoming inferior. Please do not expose LCD module direct sunlight and strong UV rays
- (2) Please pay attention to a panel side of LCD module not to contact with other materials in preserving it alone.
- (3) For the packaging box, please pay attention to the followings:
 - a. Please do not pile them up more than 5 boxes. (They are not designed so.) And please do not turn over.
 - b. Please handle packaging box with care not to give them sudden shock and vibrations. And also please do not throw them up.
 - c. Packing box and inner case for LCDs are made of cardboard. So please pay attention not to get them wet. (Such like keeping them in high humidity or wet place can occur getting them wet.)

6. LIMITED WARRANTY

Unless otherwise agreed between DATA IMAGE and customer, DATA IMAGE will replace or repair any of its LCD and LCM which is found to be defective electrically and visually when inspected in accordance with DATA IMAGE acceptance standards, for a period on one year from date of shipment. Confirmation of such date shall be based on freight documents. The warranty liability of DATA IMAGE is limited to repair and/or replacement on the terms set forth above. DATA IMAGE will not responsible for any subsequent or consequential events.

Confidential Document
15. OUTLINE DRAWING

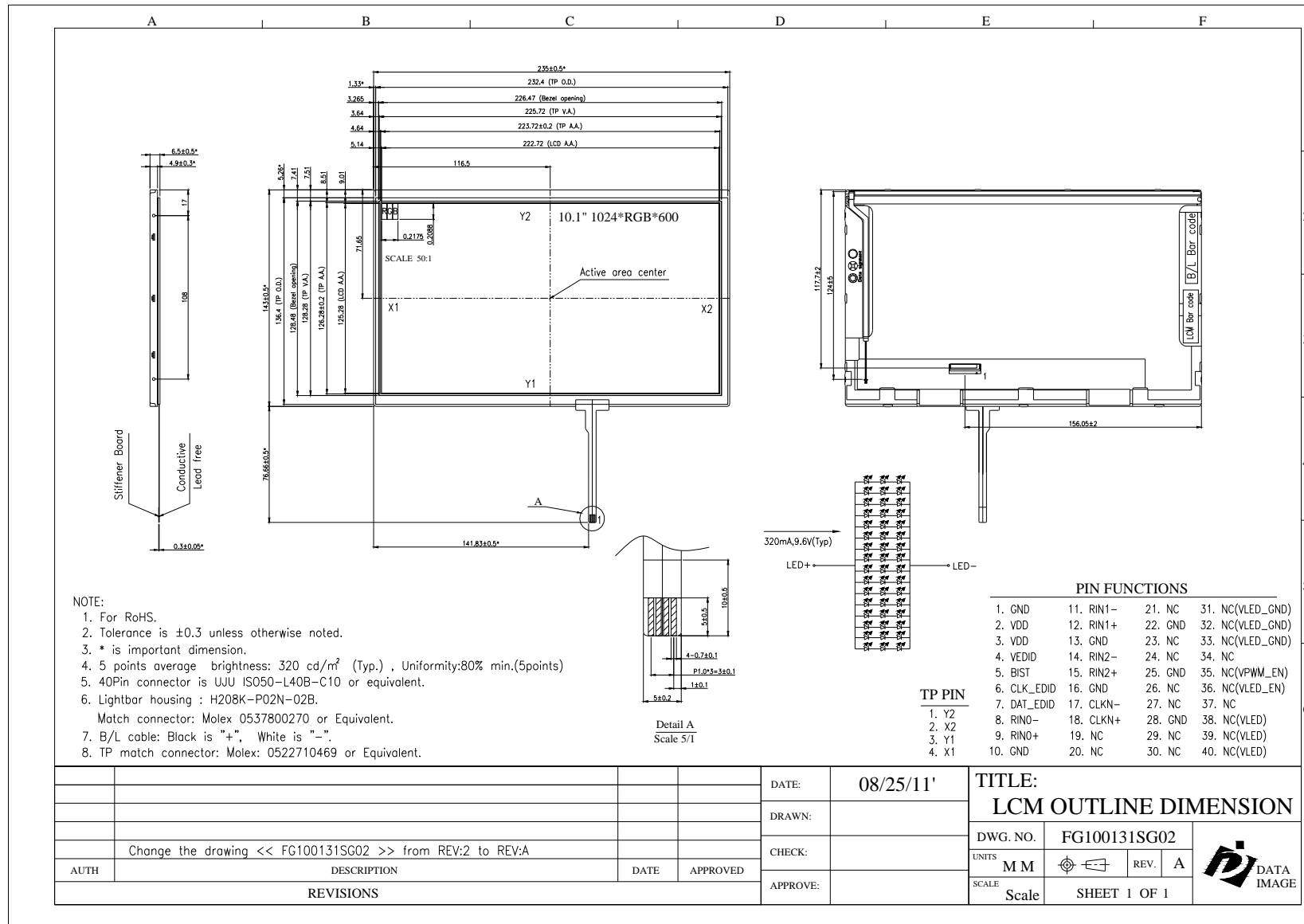

				DATE:	08/25/11'	TITLE:		
				DRAWN:		LCM OUTLINE DIMENSION		
				CHECK:		DWG. NO.	FG100131SG02	
AUTH	DESCRIPTION	DATE	APPROVED	APPROVE:		UNITS	M M	
REVISIONS						SCALE	Scale	
Change the drawing << FG100131SG02 >> from REV:2 to REV:A						REV.	A	SHEET 1 OF 1

16. PACKAGE INFORMATION

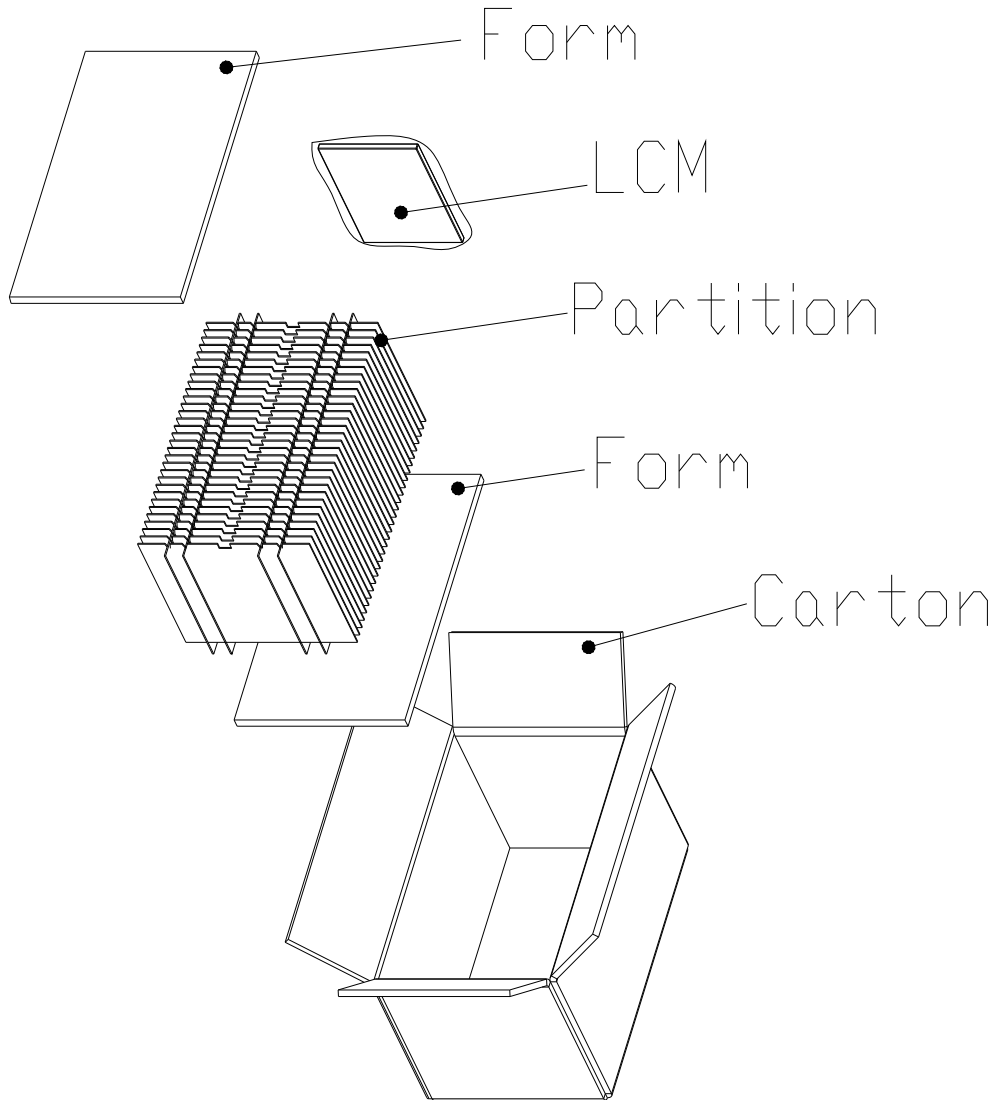

1 Carton = 16 PCS

Carton size : 482L x 282W x 279H (mm)