



DATA IMAGE CORPORATION

TFT Module Specification

PRELIMINARY

ITEM NO.: FG090040DSSWAGT1

Table of Contents

1. COVER & CONTENTS	1
2. RECORD OF REVISION	2
3. APPLICATION.....	3
4. GENERAL SPECIFICATIONS	3
5. ABSOLUTE MAXIMUM RATINGS	3
6. ELECTRICAL CHARACTERISTICS	3
7. TIMING SPECIFICATIONS	4
8. OPTICAL CHARACTERISTIC	7
9. PIN CONNECTIONS	10
10. BLOCK DIAGRAM	12
11. TOUCH PANEL CHARACTERISTICS	13
12. QUALITY ASSURANCE	14
13. LOT NUMBERING SYSTEM	15
14. LCM NUMBERING SYSTEM	15
15. PRECAUTIONS IN USE LCM	16
16. OUTLINE DRAWING	17
17. PACKAGE INFORMATION	18

Customer Companies	R&D Dept.	Q.C. Dept.	Eng. Dept.	Prod. Dept.
	JACK	ERIC	PAUL	HELEN
Approved by	Version:	Issued Date:	Sheet Code:	Total Pages:
	1	2009/1/14		18

2. RECORD OF REVISION

Rev	Date	Item	Page	Comment
1	14/JAN/09			Initial PRELIMINARY

3. APPLICATION

DVD player, Car TV, Notebook PC

4. GENERAL SPECIFICATIONS

Parameter	Specifications	Unit
Screen Size	9 (diagonal)	inch
Display Format	800(H) x (R,G,B) x 480(V)	dot
Active Area	198(H) x 112.08(V)	mm
Dot Pitch	0.0825 (H) x 0.2335 (V)	mm
Pixel Configuration	Stripe	
Outline Dimension	210.7(W) x 126.4(H) x 11.66 Max (D)	mm
Surface treatment	Anti-glare and hard coating	
Back-light	LED	
Display mode	Normally white	
Weight	390	g
View Angle direction	6 o'clock	

5. ABSOLUTE MAXIMUM RATINGS

Parameter	Symbol	MIN.	MAX.	Unit	Remark
Power supply voltage	V _{CC}	-0.3	5.0	V	Ta=25°C
Logic input voltage	V _I	-0.3	V _{CC} +0.3	V	
Operating temperature	T _{OP}	0	60	°C	Module surface*
Storage temperature	T _{ST}	-30	+70	°C	-
Humidity	Operation	20%~90% relative humidity			Ta<=38°C
	Non Operation	5%~90% relative humidity			Ta<=38°C

6. ELECTRICAL CHARACTERISTICS

f_H=30KHz, F_v=60Hz, f_{CLK}=27MHz, Ta=25°C

Parameter	Symbol	MIN.	Typ.	MAX.	Unit	Remark
Power Supply voltage for LCD	V _{CC}	+3.0	+3.3	+3.6	V	
Power Supply Current for LCD	I _{CC}		130	200	mA	V _{CC} =3.3V
Power Supply voltage for LED	V _{DD}	3.0	3.3	5.5	V	
Power Supply Current for LED	I _{DD}		--	1200	mA	V _{DD} =3.3V
	I _{DD}		--	800	mA	V _{DD} =5.0V
Ripple voltage	V _{RF}	-	-	100	mV _{P-P}	
"H" level logical input voltage	V _{IH}	0.7V _{CC}	--	V _{CC}	V	
"L" level logical input voltage	V _{IL}	0	--	0.3V _{CC}	V	
ADJ frequency		19K	20K	21K	Hz	
ADJ input voltage	V _{IH}	3.0	-	3.3	V	
	V _{IL}	0	-	0.3	V	
LED life time		20,000			Hr	Note 1

Note 1: The "LED life time" is defined as the module brightness decrease to 50% original brightness that the ambient temperature is 25 °C and ADJ = 3.3V.

7. TIMING SPECIFICATIONS

ITEM		SYMBOL	MIN.	TYP.	MAX.	UNIT
DCLK	Period	t_{CLK}	31	37.0	40.0	ns
	Dot Clock	f_{CLK}	25	27	32.11	MHz
	Low Level Width	t_{WCL}	8	-	-	ns
	High Level Width	t_{WCH}	8	-	-	
DE	Setup Time	t_{DES}	5	-	-	ns
	Hold time	t_{DEH}	10	-	-	
	Horizontal Period	t_{HP}	850	900	950	tCLK
	Horizontal Valid	t_{HV}	800			
	Horizontal Blank	t_{HBK}	50	100	150	
	Vertical Period	t_{VP}	490	500	520	tHP
	Vertical Valid	t_{VV}	480			
	Vertical Blank	t_{VBK}	10	20	40	
	Vertical Frequency	f_V	55	60	65	
DATA	Setup Time	t_{DS}	5	-	-	ns
	Hold Time	t_{DH}	10	-	-	

Note: High level of T-CON logic signal is 80%
 Low level of T-CON logic signal is 20%

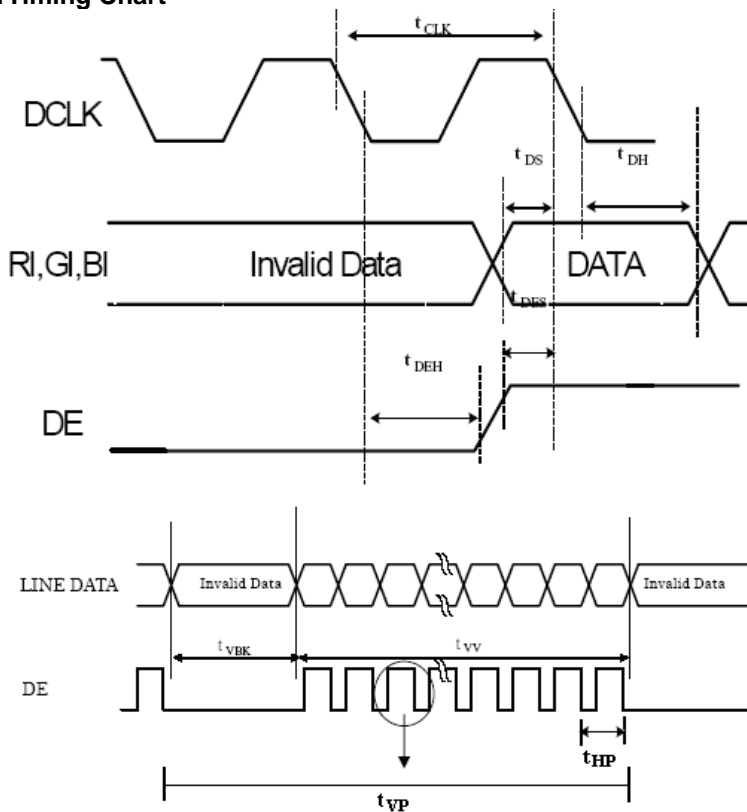
7.1 Timing Characteristic:
7.1.1 Timing Chart

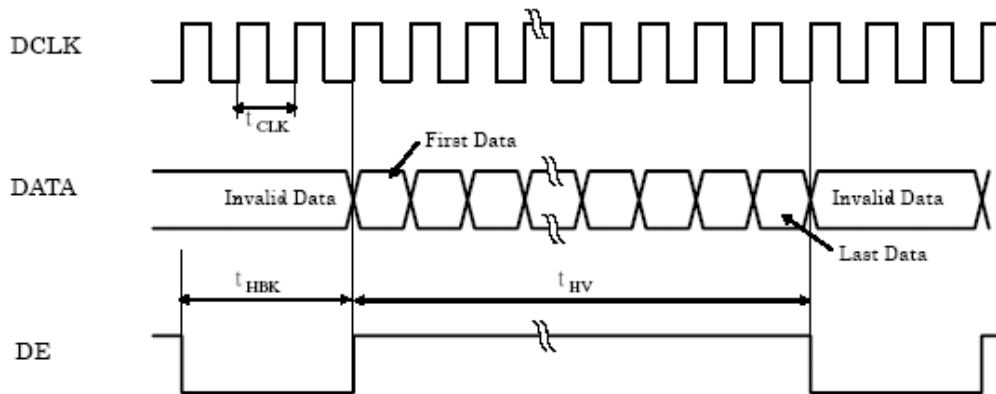

7.2 Color Data Input Assignment

		Data Signal																	
		Red						Green						Blue					
Color		R5	R4	R3	R2	R1	R0	G5	G4	G3	G2	G1	G0	B5	B4	B3	B2	B1	B0
Basic Colors	Black	0	0	0	0	0	0	0	0	0	0	0	0	0	0	0	0	0	0
	Red	1	1	1	1	1	1	0	0	0	0	0	0	0	0	0	0	0	0
	Green	0	0	0	0	0	0	1	1	1	1	1	1	0	0	0	0	0	0
	Blue	0	0	0	0	0	0	0	0	0	0	0	0	1	1	1	1	1	1
	Cyan	0	0	0	0	0	0	1	1	1	1	1	1	1	1	1	1	1	1
	Magenta	1	1	1	1	1	1	0	0	0	0	0	0	1	1	1	1	1	1
	Yellow	1	1	1	1	1	1	1	1	1	1	1	1	0	0	0	0	0	0
	White	1	1	1	1	1	1	1	1	1	1	1	1	1	1	1	1	1	1
Gray Scale of Red	Red(0) / Dark	0	0	0	0	0	0	0	0	0	0	0	0	0	0	0	0	0	0
	Red(1)	0	0	0	0	0	1	0	0	0	0	0	0	0	0	0	0	0	0
	Red(2)	0	0	0	0	1	0	0	0	0	0	0	0	0	0	0	0	0	0
	:	:	:	:	:	:	:	:	:	:	:	:	:	:	:	:	:	:	:
	:	:	:	:	:	:	:	:	:	:	:	:	:	:	:	:	:	:	:
	Red(61)	1	1	1	1	0	1	0	0	0	0	0	0	0	0	0	0	0	0
	Red(62)	1	1	1	1	1	0	0	0	0	0	0	0	0	0	0	0	0	0
Red(63)	1	1	1	1	1	1	0	0	0	0	0	0	0	0	0	0	0	0	
Gray Scale of Green	Green(0)/ Dark	0	0	0	0	0	0	0	0	0	0	0	0	0	0	0	0	0	0
	Green(1)	0	0	0	0	0	0	0	0	0	0	0	1	0	0	0	0	0	0
	Green(2)	0	0	0	0	0	0	0	0	0	0	1	0	0	0	0	0	0	0
	:	:	:	:	:	:	:	:	:	:	:	:	:	:	:	:	:	:	:
	:	:	:	:	:	:	:	:	:	:	:	:	:	:	:	:	:	:	:
	Green(61)	0	0	0	0	0	0	1	1	1	1	0	1	0	0	0	0	0	0
	Green(62)	0	0	0	0	0	0	1	1	1	1	1	0	0	0	0	0	0	0
Green(63)	0	0	0	0	0	0	1	1	1	1	1	1	0	0	0	0	0	0	
Gray Scale of Blue	Blue(0)/ Dark	0	0	0	0	0	0	0	0	0	0	0	0	0	0	0	0	0	0
	Blue (1)	0	0	0	0	0	0	0	0	0	0	0	0	0	0	0	0	0	1
	Blue (2)	0	0	0	0	0	0	0	0	0	0	0	0	0	0	0	0	1	0
	:	:	:	:	:	:	:	:	:	:	:	:	:	:	:	:	:	:	:
	:	:	:	:	:	:	:	:	:	:	:	:	:	:	:	:	:	:	:
	Blue (61)	0	0	0	0	0	0	0	0	0	0	0	0	1	1	1	1	0	1
	Blue (62)	0	0	0	0	0	0	0	0	0	0	0	0	1	1	1	1	1	0
Blue (63)	0	0	0	0	0	0	0	0	0	0	0	0	1	1	1	1	1	1	

Correspondence between Data and Display Position

	S0001	S0002	S0003	S0004	S0005	S0006	S0007	S0008	-----	S2399	S2400
C001	R001	G001	B001	R002	G002	B002	R003	G003		G800	B800
C480	R001	G001	B001	R002	G002	B002	R003	G003		G800	B800

8. OPTICAL CHARACTERISTIC

Parameter		Symbol	Condition	MIN.	TYP.	MAX.	Unit	Remarks
Viewing Angle	Horizontal	θ_{x+}	Center CR \geq 10	60	70	--	deg	Note 1,4
		θ_{x-}		60	70	--		
	Vertical	θ_{y+}		40	50	--		
		θ_{y-}		50	60	--		
Contrast Ratio		CR	at optimized viewing angle	300	350			Note 1,3
Response time	Rise	Tr	Center	-	17	--	ms	Note 1,6
	Fall	Tf	$\theta_x=\theta_y=0^\circ$	-	11	--	ms	
Uniformity		B-uni	$\theta_x=\theta_y=0^\circ$	70	80	--	%	Note1,5
Brightness	Without T/P	L	$\theta_x=\theta_y=0^\circ$	320	400	--	cd/m ²	Note 1,2,4
	With T/P		ADJ=3.3V	250	320			
Chromaticity	x_W	Center $\theta_x=\theta_y=0^\circ$		0.27	0.32	0.37		Note 1,7
	y_W			0.29	0.34	0.39		
	x_R			0.53	0.58	0.63		
	y_R			0.31	0.36	0.41		
	x_G			0.29	0.34	0.39		
	y_G			0.49	0.54	0.59		
	x_B			0.1	0.15	0.20		
	y_B			0.09	0.14	0.19		
Image sticking		tis	2 hours			2	Sec	Note 8

The following optical specifications shall be measured in a darkroom or equivalent state (ambient luminance ≤ 1 lux, and at room temperature). The operation temperature is $25^\circ\text{C} \pm 2^\circ\text{C}$. The measurement method is shown in Note1.

Note1: The method of optical measurement:

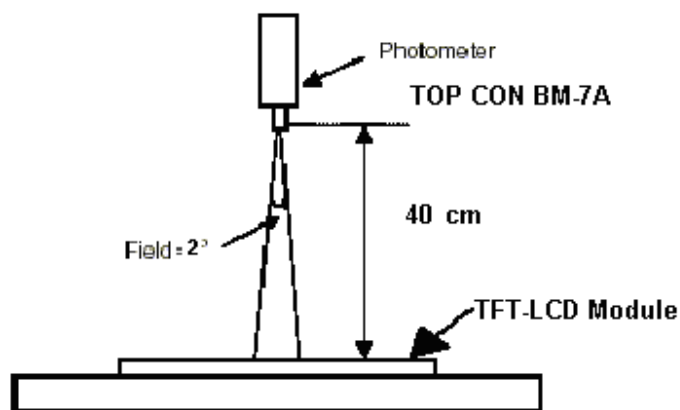

Note2: Measured at the center area of the panel and at the viewing angle of the $\theta_x = \theta_y = 0^\circ$ (Note4) When all the input terminal of LCD Panel are electrically opened.

Note3: Definition of Contrast Ratio (CR):

$$CR = \frac{\text{Luminance with all pixels in white state}}{\text{Luminance with all pixels in Black state}}$$

Note4: Definition of Viewing Angle

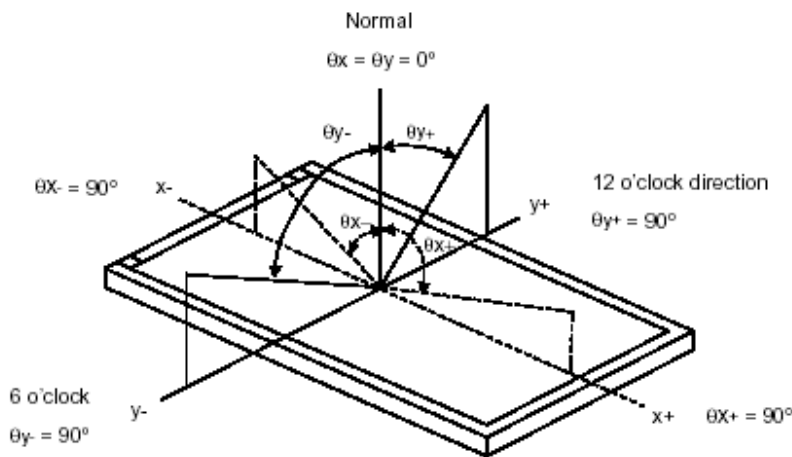

Note 5: Definition of Brightness Uniformity (B-uni):

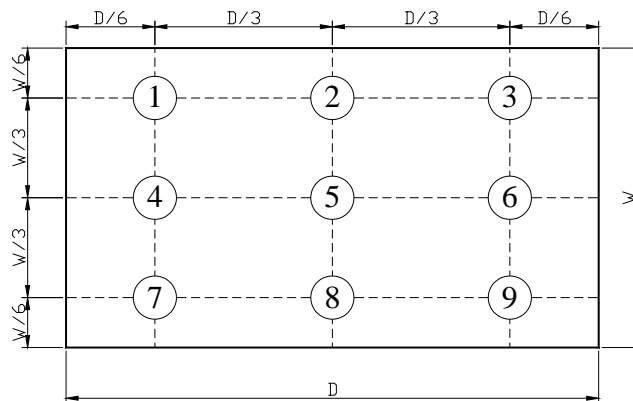

$$B\text{-uni} = \frac{\text{Minimum luminance of 9 points}}{\text{Maximum luminance of 9 points}} \quad (\text{Note 5}).$$

Note6: Definition of Response Time:

The Response Time is set initially by defining the "Rising Time (T_r)" and the "Falling Time (T_f)" respectively. T_r and T_f are defined as following figure.

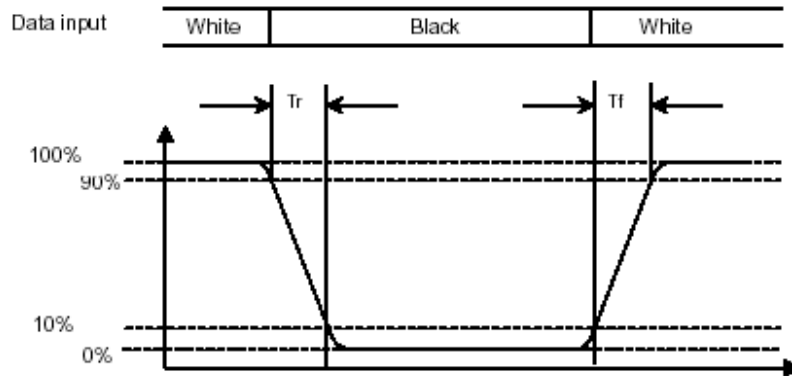

Note 7: Definition of Chromaticity:

The color coordinates (x_w, y_w) , (x_r, y_r) , (x_g, y_g) , and (x_b, y_b) are obtained with all pixels in the viewing field at white, red, green, and blue states, respectively.

Note 8: Definition of Image sticking (t_{is}):

Continuously display the test pattern shown in the figure below for 2 hours. Then display a completely white screen. The previous image shall not persist more than 2 sec at 25 °C

Image sticking pattern

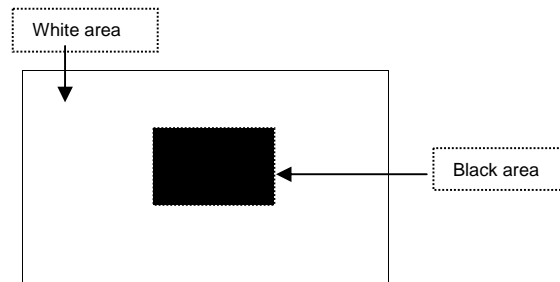

9. PIN CONNECTIONS

Pin NO.	SYMBOL	DESCRIPTION
1	V _{ss}	Power Ground
2	V _{ss}	Power Ground
3	ADJ	Brightness control for LED B/L
4	VDD	Power Supply for LED Driver circuit
5	VDD	Power Supply for LED Driver circuit
6	VDD	Power Supply for LED Driver circuit
7	V _{cc}	Power Supply for Digital Circuit
8	V _{cc}	Power Supply for Digital Circuit
9	DE	Data Enable
10	V _{ss}	Power Ground
11	V _{ss}	Power Ground
12	V _{ss}	Power Ground
13	B5	Blue Data 5 (MSB)
14	B4	Blue Data 4
15	B3	Blue Data 3
16	V _{ss}	Power Ground
17	B2	Blue Data 2
18	B1	Blue Data 1
19	B0	Blue Data 0 (LSB)
20	V _{ss}	Power Ground
21	G5	Green Data 5 (MSB)
22	G4	Green Data 4
23	G3	Green Data 3
24	V _{ss}	Power Ground
25	G2	Green Data 2
26	G1	Green Data 1
27	G0	Green Data 0 (LSB)
28	V _{ss}	Power Ground
29	R5	Red Data 5 (MSB)
30	R4	Red Data 4
31	R3	Red Data 3
32	V _{ss}	Power Ground
33	R2	Red Data 2
34	R1	Red Data 1
35	R0	Red Data 0
36	V _{ss}	Power Ground
37	V _{ss}	Power Ground
38	DCLK	Clock Signals ; Latch Data at the Falling Edge
39	V _{ss}	Power Ground
40	V _{ss}	Power Ground

Remarks:

- 1) ADJ is brightness control Pin. The larger of the pulse duty is, the higher of the brightness.
- 2) ADJ signal is 0~3.3V.Operation frequency is 20KHz
- 3) VSS PIN must be grounding, can not be floating.

9.1 Power Signal Sequence

Remarks:

*1) Power Signal sequence:

$t1 \leq 10\text{ms}$; $1 \text{ sec} \leq t5$

$50\text{ms} \leq t2$; $200\text{ms} \leq t6$

$0 < t3 \leq 50\text{ms}$; $200\text{ms} \leq t7$

$0 < t4 \leq 10\text{ms}$

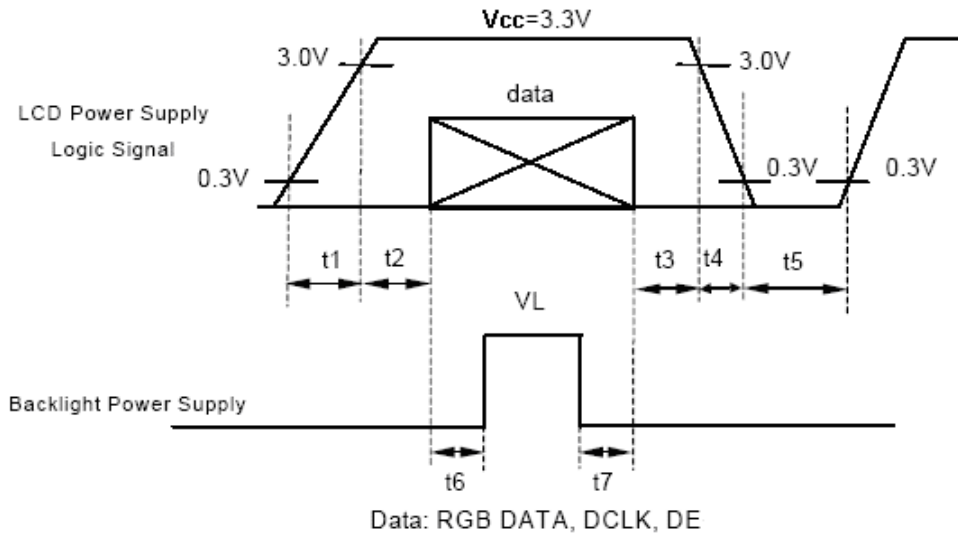

*2) VCC-dip condition:

(1) $2.7 \text{ V} \leq VCC < 3.0\text{V}$, $t_d \leq 10 \text{ ms}$

(2) $VCC > 3.0\text{V}$, VCC-dip condition should be the same with VCC-turn-on condition.

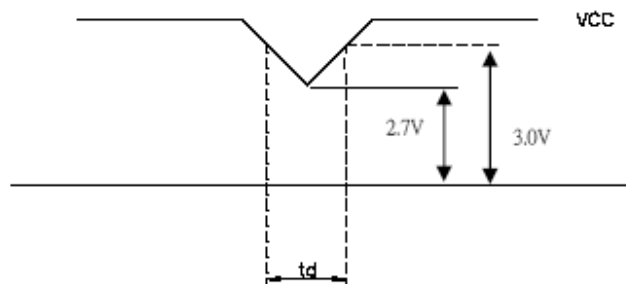

10. BLOCK DIAGRAM

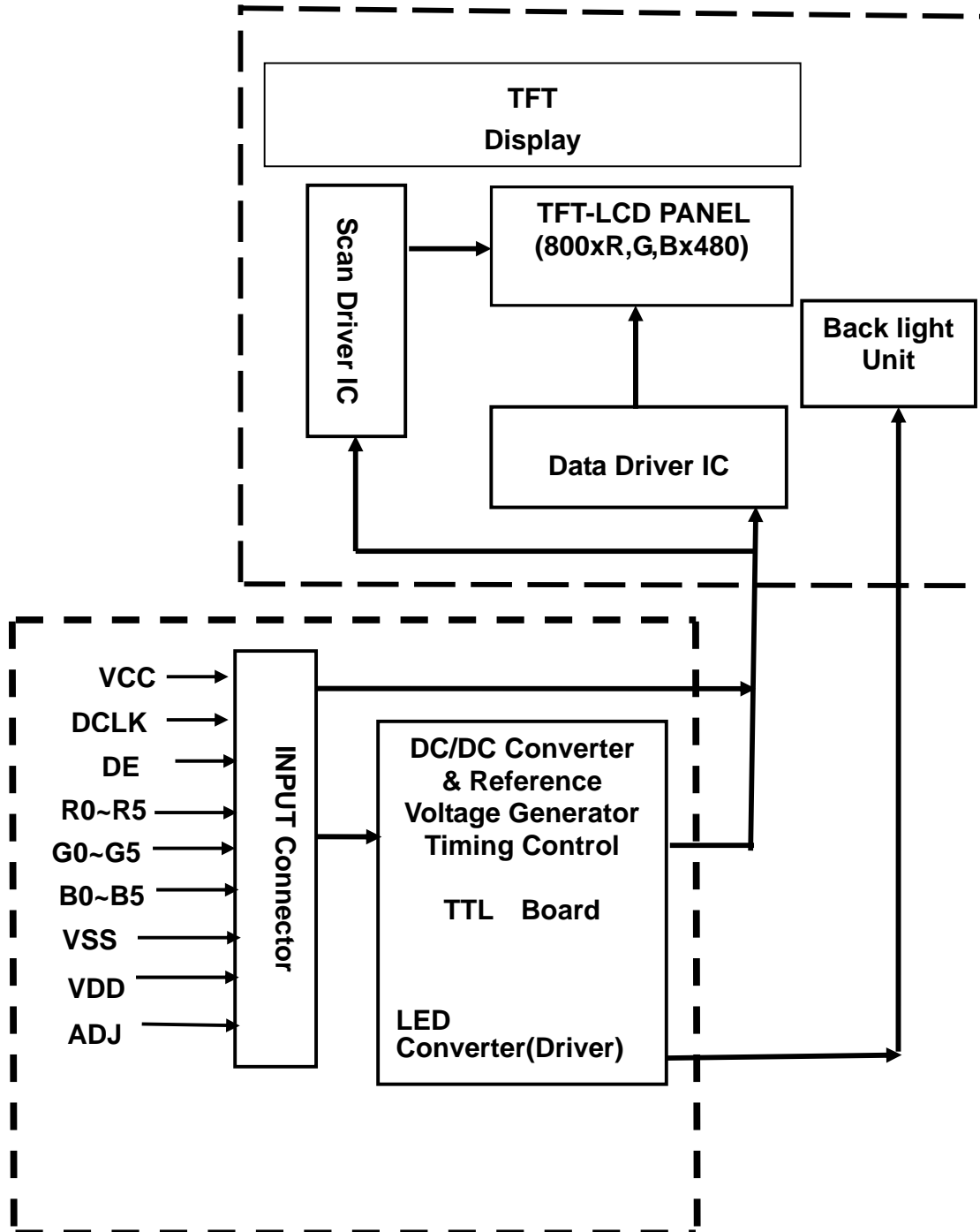

11. TOUCH PANEL CHARACTERISTICS

1. Input Method and Activation Force

Input Method	Activation Force
0.8mm dia. Delrin Polyacetal stylus	50g Max
8mm dia. Silicon "finger"	50g Max

2. Typical Optical Characteristics

ITEM	Parameter
Visible Light Transmission	80% Typ.
Haze	5% Typ.

3. Electrical Specification

ITEM	Parameter
Operating Voltage	DC 7V Max
Circuit close resistance	X 300~1300Ω
	Y 100~800Ω
Circuit open resistance	20MΩ Min at 25V DC
Contact bounce	≤20ms
Linear Test	≤1.5%

4. Linearity

ITEM	Parameter
Linear Test Specification Direction	X ≤1.5%
	Y ≤1.5%

5. Specification

ITEM	Parameter
Operating Temperature	-20°C~+60°C
Storage Temperature	-30°C~+70°C

6. Durability test:

6.1 Touch panel is hit 1 millions times with a silicone rubber of R8 finger, hitting rate is by 200g at 2 times per second. The measurement must satisfy the following:

- Circuit close resistance: x 300~1300Ω ;
y 100~800Ω
- Circuit open resistance: ≥20MΩ at 25V DC
- Contact bounce: ≤20ms
- Linearity test: ≤3.0%

6.2 Stylus writing

Touch panel is drawn by R0.8 Darling stylus pen, at 250g forces, repeat one inch by 100k times. The measurement must satisfy the following:

- Circuit close resistance: x 300~1300Ω;
y 100~800Ω
- Circuit open resistance: ≥20MΩ at 25V DC
- Contact bounce: ≤20ms
- Linearity test: ≤3.0%

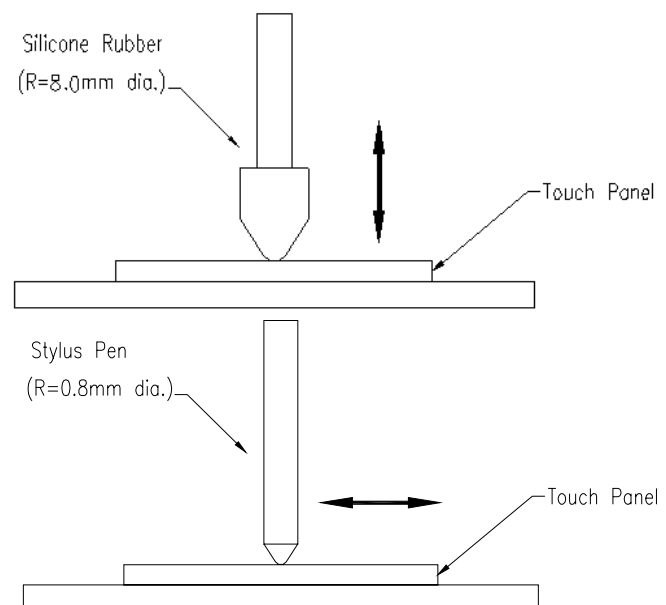

12. QUALITY ASSURANCE

12.1 Test Condition

12.1.1 Temperature and Humidity(Ambient Temperature)

Temperature : $25 \pm 5^{\circ}\text{C}$

Humidity : $65 \pm 5\%$

12.1.2 Operation

Unless specified otherwise, test will be conducted under function state.

12.1.3 Container

Unless specified otherwise, vibration test will be conducted to the product itself without putting it in a container.

12.1.4 Test Frequency

In case of related to deterioration such as shock test. It will be conducted only once.

12.1.5 Test Method

Reliability Test Item & Level		Test Level
No.	Test Item	
1	High Temperature Storage Test	T=70°C,240hrs
2	Low Temperature Storage Test	T=-30°C,240hrs
3	High Temperature Operation Test	T=60°C,240hrs
4	Low Temperature Operation Test	T=0°C,240hrs
5	High Temperature and High Humidity Operation Test	T=38°C,90%RH,240hrs
6	Thermal Cycling Test (No operation)	0°C +25°C +60°C , 50 Cycles 60 min 30 min 60 min
7	Vibration Test (No operation)	Frequency:10 ~ 57 Hz Amplitude:1.0 mm 58 ~ 500 Hz, 1G Sweep Time:11min Test Period:3hrs (1hrs for each Direction of X,Y,Z)
8	Shock Test (No operation)	80G, 6ms Direction:± X,± Y,± Z Cycle:1 times

13. LOT NUMBERING SYSTEM

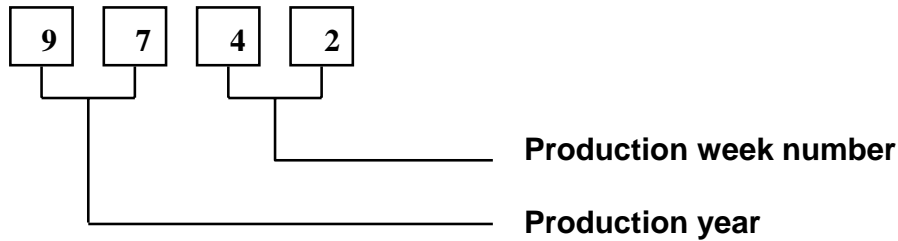

14. LCM NUMBERING SYSTEM

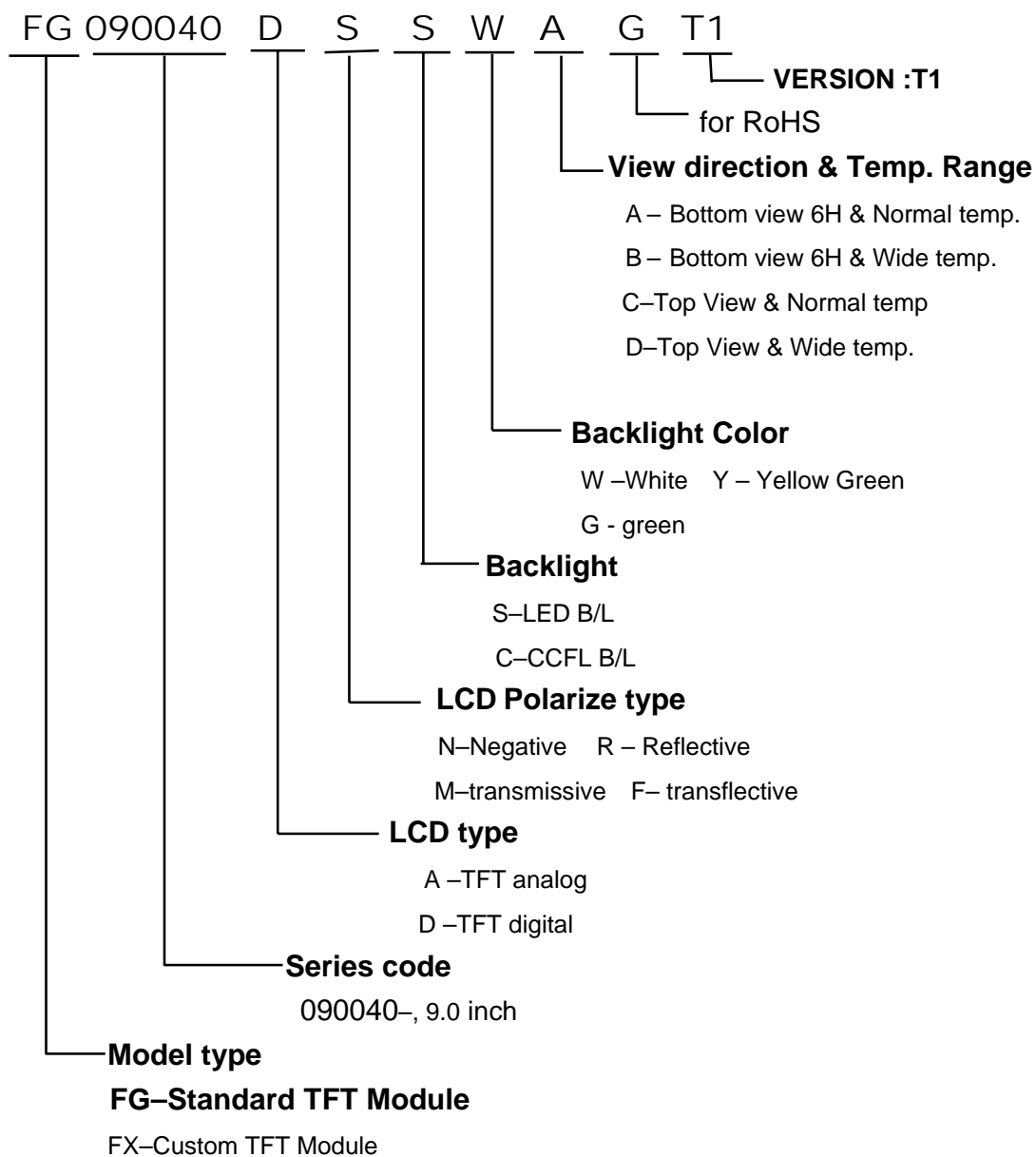

15. PRECAUTION FOR USING LCM

1. LIQUID CRYSTAL DISPLAY (LCD)

LCD is made up of glass, organic sealant, organic fluid, and polymer based polarizers. The following precautions should be taken when handling,

- (1). Keep the temperature within range of use and storage. Excessive temperature and humidity could cause polarization degradation, polarizer peel off or bubble.
- (2). Do not contact the exposed polarizers with anything harder than an HB pencil lead. To clean dust off the display surface, wipe gently with cotton, chamois or other soft material soaked in petroleum benzin.
- (3). Wipe off saliva or water drops immediately. Contact with water over a long period of time may cause polarizer deformation or color fading, while an active LCD with water condensation on its surface will cause corrosion of ITO electrodes.
- (4). Glass can be easily chipped or cracked from rough handling, especially at corners and edges.
- (5). Do not drive LCD with DC voltage.

2. Liquid Crystal Display Modules

2.1 Mechanical Considerations

LCM are assembled and adjusted with a high degree of precision. Avoid excessive shocks and do not make any alterations or modifications. The following should be noted.

- (1). Do not tamper in any way with the tabs on the metal frame.
- (2). Do not modify the PCB by drilling extra holes, changing its outline, moving its components or modifying its pattern.
- (3). Do not touch the elastomer connector, especially insert an backlight panel (for example, EL).
- (4). When mounting a LCM make sure that the PCB is not under any stress such as bending or twisting. Elastomer contacts are very delicate and missing pixels could result from slight dislocation of any of the elements.
- (5). Avoid pressing on the metal bezel, otherwise the elastomer connector could be deformed and lose contact, resulting in missing pixels.

2.2 Static Electricity

LCM contains CMOS LSI's and the same precaution for such devices should apply, namely

- (1). The operator should be grounded whenever he/she comes into contact with the module. Never touch any of the conductive parts such as the LSI pads, the copper leads on the PCB and the interface terminals with any parts of the human body.
- (2). The modules should be kept in antistatic bags or other containers resistant to static for storage.
- (3). Only properly grounded soldering irons should be used.
- (4). If an electric screwdriver is used, it should be well grounded and shielded from commutator sparks.

(5) The normal static prevention measures should be observed for work clothes and working benches; for the latter conductive (rubber) mat is recommended.

(6). Since dry air is inductive to statics, a relative humidity of 50-60% is recommended.

2.3 Soldering

- (1). Solder only to the I/O terminals.
- (2). Use only soldering irons with proper grounding and no leakage.
- (3). Soldering temperature : $280^{\circ}\text{C} \pm 10^{\circ}\text{C}$
- (4). Soldering time: 3 to 4 sec.
- (5). Use eutectic solder with resin flux fill.
- (6). If flux is used, the LCD surface should be covered to avoid flux spatters. Flux residue should be removed after wards.

2.4 Operation

- (1). The viewing angle can be adjusted by varying the LCD driving voltage V_0 .
- (2). Driving voltage should be kept within specified range; excess voltage shortens display life.
- (3). Response time increases with decrease in temperature.
- (4). Display may turn black or dark blue at temperatures above its operational range; this is (however not pressing on the viewing area) may cause the segments to appear "fractured".
- (5). Mechanical disturbance during operation (such as pressing on the viewing area) may cause the segments to appear "fractured".

2.5 Storage

If any fluid leaks out of a damaged glass cell, wash off any human part that comes into contact with soap and water. Never swallow the fluid. The toxicity is extremely low but caution should be exercised at all the time.

2.6 Limited Warranty

Unless otherwise agreed between DATA IMAGE and customer, DATA IMAGE will replace or repair any of its LCD and LCM which is found to be defective electrically and visually when inspected in accordance with DATA IMAGE acceptance standards, for a period on one year from date of shipment. Confirmation of such date shall be based on freight documents. The warranty liability of DATA IMAGE is limited to repair and/or replacement on the terms set forth above. DATA IMAGE will not responsible for any subsequent or consequential events.

Confidential Document
 16. OUTLINE DRAWING

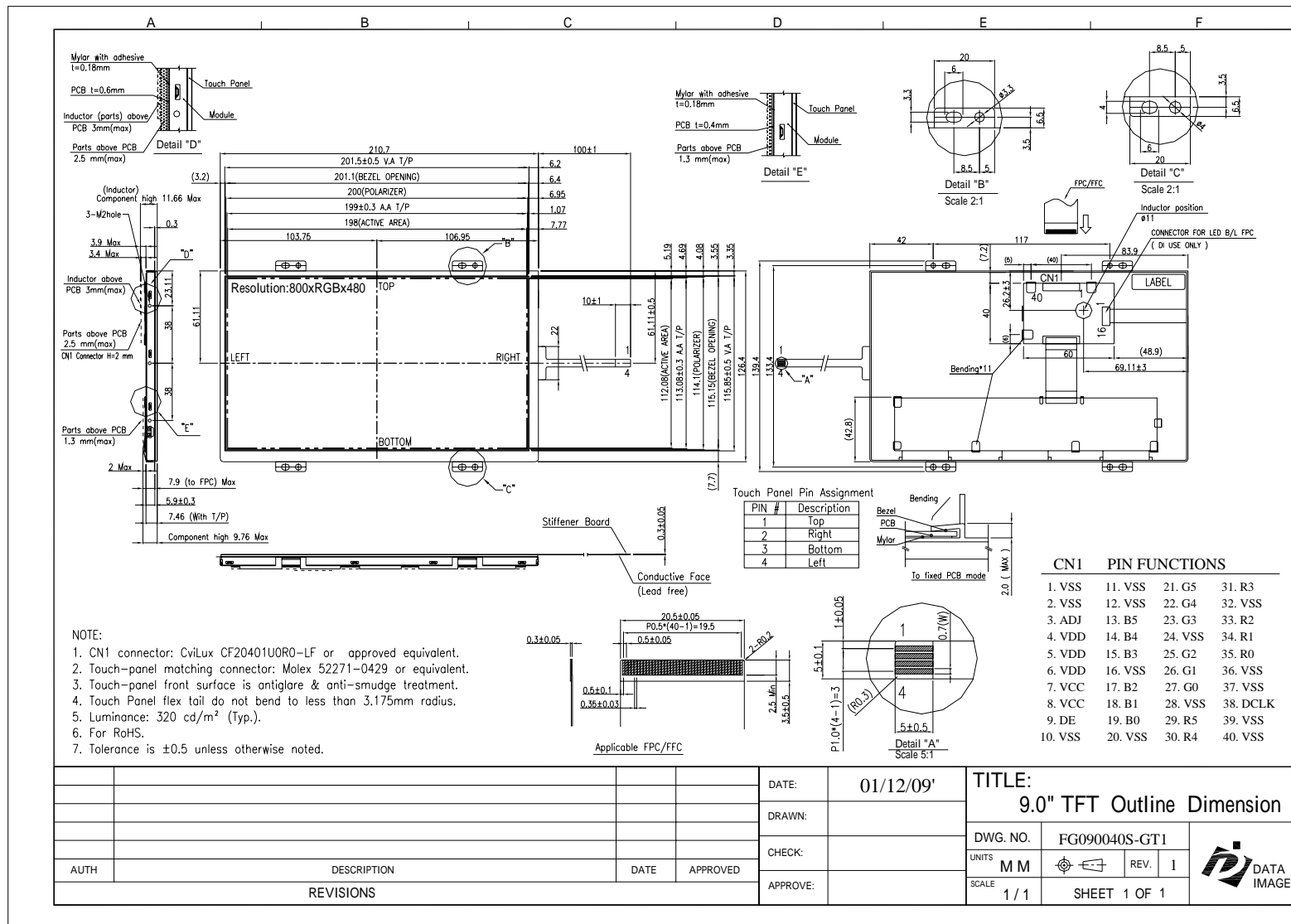

DATE:	01/12/09'	TITLE: 9.0" TFT Outline Dimension	
DRAWN:		DWG. NO.	FG090040S-GT1
CHECK:		UNITS	M MM
APPROVE:		SCALE	1 / 1
		REV.	1
		SHEET 1 OF 1	

17. PACKAGE INFORMATION

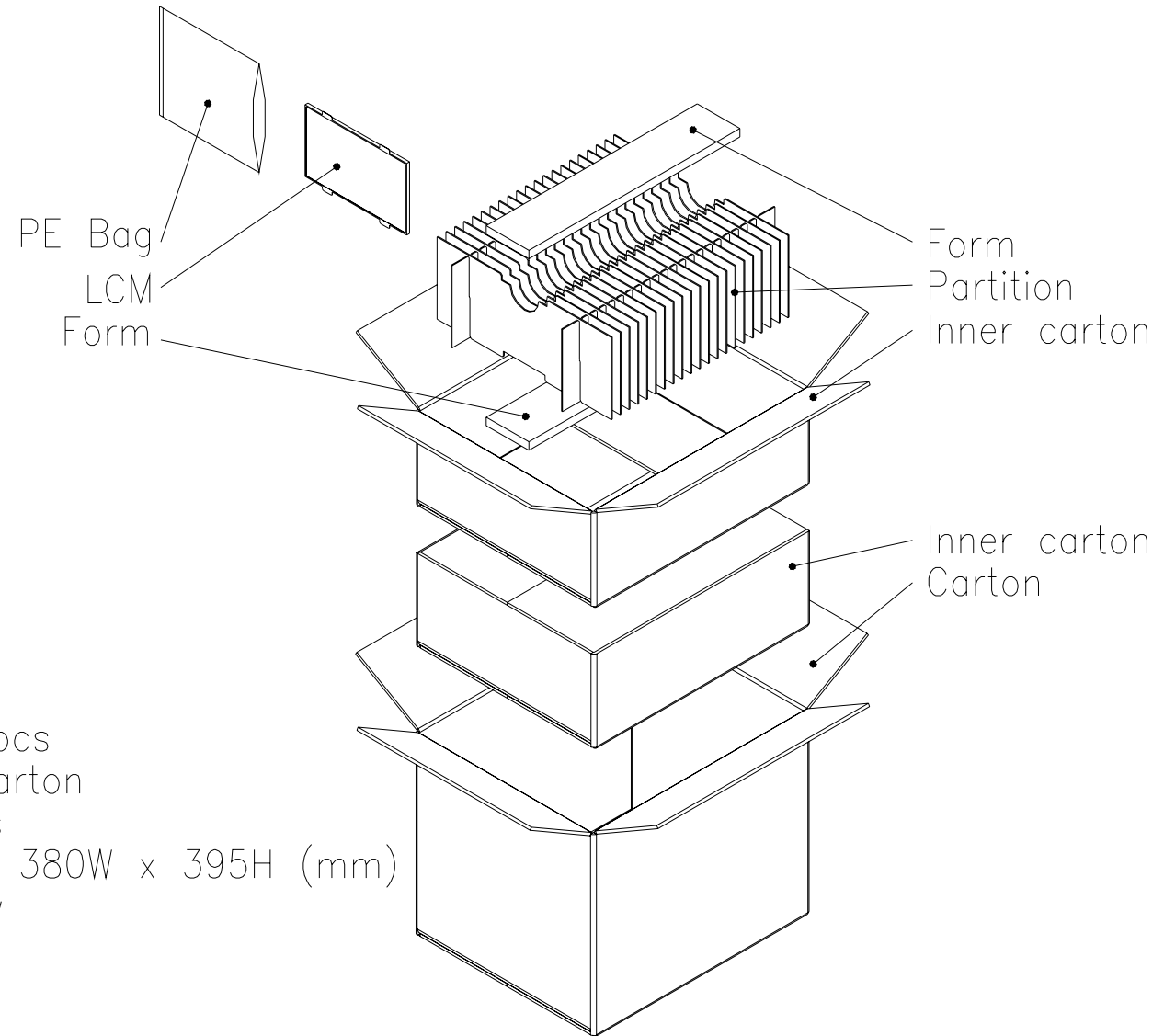

1 Inner carton= 20 pcs
1 Carton= 2 Inner carton
= 20 pcs*2= 40 pcs
Carton size : 465L x 380W x 395H (mm)
Total Weight ÷20 kgw